

## **Atlas Copco Stationary Air Compressors**

### **Instruction book**

SF1 - SF2 - SF4 Skid -Tank-mounted  
SF6 - SF8 Twin  
SF6 - SF8 - SF11 - SF15 Multi

Copyright 2003, Atlas Copco Airpower n.v, Antwerp, Belgium.  
Any unauthorized use or copying of the contents or any part thereof is prohibited. This applies in particular to trademarks, model denominations, part numbers and drawings.

This instruction book meets the requirements for instructions specified by the machinery directive 98/37/EC and is valid for CE as well as non-CE labelled machines.

**Note: The PED instructions for this machine are included at the end of the book.**

**No. 2920 1521 00**

**Registration code: APC SF / 38 / 980**

2003-10

[www.atlascopco.com](http://www.atlascopco.com)

This instruction book describes how to handle the machines to ensure safe operation, optimum efficiency and long service life.

**Read this book before putting the machine into operation** to ensure correct handling, operation and proper maintenance from the beginning. The maintenance schedule comprises measures for keeping the machine in good condition.

Keep the book available for the operator and make sure that the machine is operated and that maintenance is carried out according to the instructions. Record all operating data, maintenance performed, etc. in an operator's logbook available from Atlas Copco. Follow all relevant safety precautions, including those mentioned on the cover of this book.

Repairs must be carried out by trained personnel from Atlas Copco who can be contacted for any further information.

In all correspondence mention the type and the serial number, shown on the data plate.

For all data not mentioned in the text, see sections "Preventive maintenance schedule" and "Principal data".

**The company reserves the right to make changes without prior notice.**

<b>1 LEADING PARTICULARS.....</b>	<b>5</b>
1.1 General description.....	5
1.1.1 Compressor variants .....	5
1.1.2 Compressor elements (Fig. 1.1).....	5
1.2 Air flow .....	9
1.3 Cooling and condensate drain systems (Fig. 1.9).....	9
1.4 Regulating system on SF Skid - Tank-mounted - Twin .....	10
1.5 Regulating system on SF Multi .....	11
1.5.1 Controlling the compressor .....	11
1.5.2 Protecting the compressor .....	11
1.5.3 Monitoring components subject to service.....	11
1.5.4 Automatic restart after voltage failure .....	11
1.5.5 Control panel (Fig. 1.11) .....	12
1.5.6 Display – keys .....	13
1.5.7 Function keys (5-Fig. 1.11) .....	13
1.6 Electric cabinet on SF Multi .....	15
1.7 Air dryer on SF Full-Feature (Fig. 1.15).....	16
<b>2 INSTALLATION .....</b>	<b>17</b>
2.1 Dimension drawings (Figs. 2.1 up to 2.5).....	17
2.2 Installation proposal (Fig. 2.6) .....	22
2.3 Electrical connections .....	24
2.4 Pictographs .....	27
<b>3 OPERATING INSTRUCTIONS .....</b>	<b>28</b>
3.1 Initial start-up .....	28
3.2 Starting.....	28
3.2.1 Multi.....	28
3.2.2 Skid - Tank-mounted - Twin .....	28
3.3 During operation .....	29
3.3.1 Multi.....	29
3.3.2 Skid - Tank-mounted - Twin .....	29
3.4 Stopping.....	29
3.4.1 Multi.....	29
3.4.2 Skid - Tank-mounted - Twin .....	29
3.5 Taking out of operation at end of compressor service life .....	29
<b>4 MAINTENANCE .....</b>	<b>30</b>
4.1 Compressor drive motors .....	30
4.2 Preventive maintenance schedule for the compressor.....	30
<b>5 ADJUSTMENTS AND SERVICING PROCEDURES .....</b>	<b>32</b>
5.1 Air filter (1-Figs. 1.7/1.8) .....	32
5.2 Belt exchange/tensioning (Fig. 5.1) .....	32
5.3 Coolers.....	32
5.4 Safety valve .....	33
<b>6 PROBLEM SOLVING .....</b>	<b>34</b>
<b>7 PRINCIPAL DATA .....</b>	<b>35</b>
7.1 Electric cable size for SF1-8 .....	35
7.2 Electric cable size for SF 6-15 Multi .....	35
7.3 Overload relays for SF1-8.....	36
7.4 Overload relays for SF6-15 Multi .....	36
7.5 Main fuses for SF1-8.....	37
7.6 Main fuses for SF6-15 Multi.....	37
7.7 Reference conditions/limitations .....	37
7.8 SF1-4 8bar 50 Hz 1) .....	38
7.9 SF2-4 10 bar 50 Hz 1) .....	38
7.10 SF1-4 100 psi 60 Hz 1).....	38
7.11 SF2-4 145 psi 60 Hz 1).....	38
7.12 SF6-15 Multi 8 bar 50 Hz 1).....	39
7.13 SF6-15 Multi 10 bar 50 Hz 1).....	39
7.14 SF6-15 Multi 100 psi 60 Hz 1) .....	39
7.15 SF6-15 Multi 125 psi 60 Hz 1).....	40

7.16 SF6-15 Multi 145 psi 60 Hz 1)	40
<b>8 REGULATOR FUNCTIONS FOR SF MULTI</b>	<b>41</b>
8.1 Menu-driven control programs	41
8.1.1 Function of control programs	42
8.1.2 Main screen	42
8.1.3 Calling up other menus	44
8.2 Quick look at actual compressor status	44
8.3 Status data menu	45
8.3.1 No message exists	45
8.3.2 A shut-down message exists	45
8.3.3 A warning message exists	46
8.3.4 A service warning message exists	47
8.4 Measured data menu	47
8.5 Counters menu	48
8.6 Test menu	48
8.7 Modify parameters menu	49
8.8 Modifying parameters	49
8.8.1 Modifying the pressure bands	50
8.9 Modifying protection settings	51
8.9.1 Checking protections for compressor modules	51
8.9.2 Modifying protections for Dryer LAT on Full-Feature machines	52
8.10 Modifying service plans	52
8.11 Programming Clock function	54
8.11.1 Programming start/stop/pressure band commands	54
8.11.2 To activate/deactivate the timer	56
8.11.3 To modify a command	56
8.11.4 To add a command	57
8.11.5 To delete commands	58
8.12 Configuration menu	59
8.12.1 Programming compressor control modes	60
8.13 Service menu	60
8.14 Saved data menu	63
8.15 Programmable settings	64
8.15.1 Regulation settings	64
8.15.2 Service settings	65
<b>9 CONVERSION LIST OF SI UNITS INTO US/BRITISH UNITS</b>	<b>65</b>

# 1 LEADING PARTICULARS

## 1.1 General description

SF1 up to SF15 are stationary, oil-free compressors driven by an electric motor.

### 1.1.1 Compressor variants

#### SF Skid (Fig. 1.2)

The components of the compressor are housed in a bodywork with removable front/top panel. The compressor is mounted on a frame designed to allow easy installation at the required spot.

#### SF Tank-mounted (Fig. 1.3)

The components of the compressor are housed in a bodywork with removable front/top panel. The compressor is mounted on an air receiver.

#### SF Twin (Fig. 1.4)

Two compressor modules are mounted on an air receiver. Each module is provided with its own control panel.

#### SF Multi Pack

The compressors have two up to four compressor modules enclosed in a sound-insulated bodywork. The front door comprises an Elektronikon regulator including the start and stop buttons. An emergency stop button is also provided. An electric cabinet comprising the motor starter is installed behind the front door.

#### SF Multi Full-Feature (Figs. 1.5 and 1.6)

Full-Feature compressors are Pack compressors additionally provided with an air dryer integrated in the bodywork. The dryer removes moisture from compressed air by cooling the air to near freezing point and automatically draining the condensate. See section 1.7.

### 1.1.2 Compressor elements (Fig. 1.1)

Each compressor element consists of a fixed scroll-shaped housing and a scroll-shaped rotor. Air enters the compressor element through inlet opening (1). Once the air is drawn in, the orbiting scroll (4) seals the inlet opening and forces the air into a continuously decreasing space. As scroll (4) keeps orbiting, this process of compression is constantly repeated, resulting in discharging of oil-free compressed air through outlet opening (3).

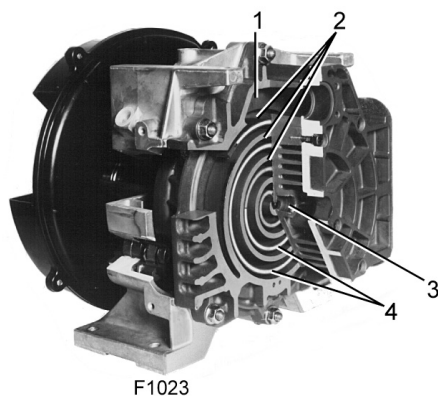

- |   |                       |
|---|-----------------------|
| 1 | Air inlet             |
| 2 | Fixed scroll          |
| 3 | Compressed air outlet |
| 4 | Orbiting scroll       |

Fig. 1.1 Compressor element



- 1 Control panel
- 2 Air outlet valve

Fig. 1.2 SF4 Skid



- 1 Control panel
- 2 Air outlet valve

1.3 SF4 Tank-mounted



- 1 Control panels
- 2 Air outlet valve

Fig. 1.4 SF Twin



- 1 Elektronikon regulator
- 2 Electric cabinet
- 3 Air outlet valve
- 4 Dryer (on Full-Feature)
- 5 Compressor modules
- S3 Emergency stop button

Fig. 1.5 SF8FF Multi



- 1 Elektronikon regulator
- 2 Electric cabinet
- 3 Air outlet valve
- 4 Dryer (on Full-Feature)
- 5 Compressor modules
- 6 Safety valve (ASME)
- S3 Emergency stop button

Fig. 1.6 SF15FF Multi

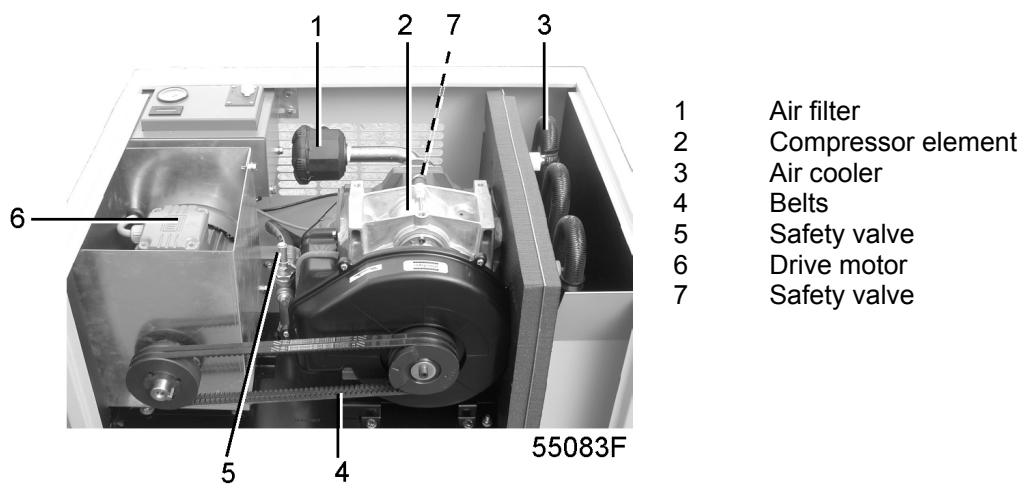

- 1 Air filter
- 2 Compressor element
- 3 Air cooler
- 4 Belts
- 5 Safety valve
- 6 Drive motor
- 7 Safety valve

Fig. 1.7 Details of a compressor module on SF Tank-mounted



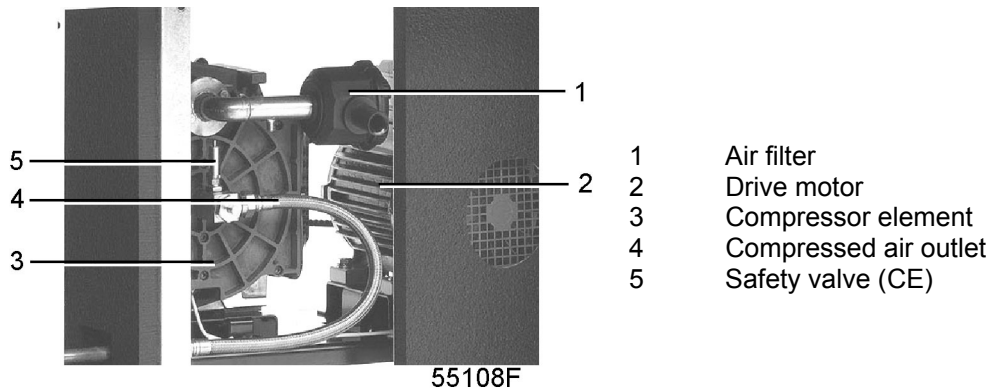

- 1 Air filter
- 2 Drive motor
- 3 Compressor element
- 4 Compressed air outlet
- 5 Safety valve (CE)

Fig. 1.8 Details of a compressor module on SF Multi

### 1.2 Air flow

Air is drawn through the air filter into the compressor modules and is compressed. Compressed air is discharged through the check valve and air cooler towards the air net.

### 1.3 Cooling and condensate drain systems (Fig. 1.9)

Each compressor element is cooled by a fan. The fan is mounted on the drive shaft of the compressor element. The cooling air is blown over the compressor element and air cooler via a duct.

For SF Multi two fans, driven by electric motors, expel warm air from the bodywork.

SF Multi have a condensate trap, with an automatic condensate outlet (2) and a manual drain valve (1).

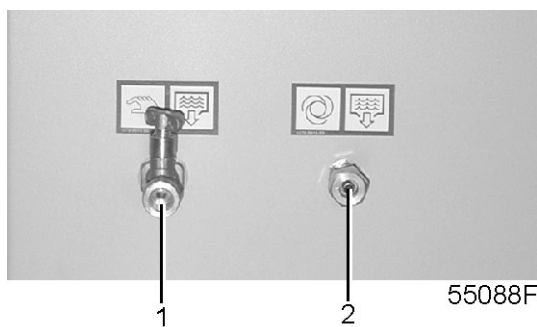

- 1 Manual condensate drain valve
- 2 Automatic condensate outlet

Fig. 1.9 Condensate drains on SF Multi

## 1.4 Regulating system on SF Skid - Tank-mounted - Twin

The air net pressure is kept within limits by a pressure switch mounted in the cabinet below the control panel (Fig. 1.10). The switch is connected to the air outlet and electrically connected in the circuit of the drive motor. The switch opens and closes its contacts at pre-set pressures.

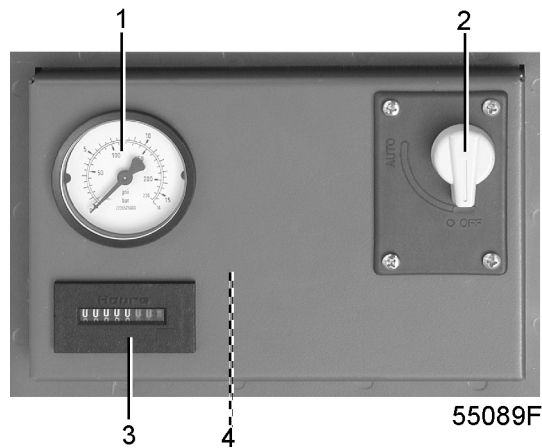

- 1 Pressure gauge
- 2 On/off switch
- 3 Hourmeter
- 4 Air pressure switch/circuit breaker

Fig. 1.10 Control panel SF Skid - Tank-mounted - Twin

When the contacts are closed, the circuit to the drive motor is made: the compressor is operating. The air output is maximum.

When the pressure reaches the pre-set maximum, the circuit to the drive motor is broken, causing the compressor to stop. The air output is stopped.

### Protecting the compressor

The compressor will be shut down in case temperature switch (TSHH11-Fig. 2.7) trips.

### Warning

Before carrying out any inspection or repair, stop the compressor, switch off the voltage, open the isolating switch and depressurize the compressor.

## **1.5 Regulating system on SF Multi**

SF Multi are provided with an Elektronikon® regulator (Fig. 1.11) to control the compressor.

The following is a short description of the main functions of the regulator. Consult section 8 for a detailed description of all functions.

### **1.5.1 Controlling the compressor**

The Elektronikon regulator keeps the net pressure within programmable limits by starting and stopping the compressor modules, depending on the air consumption. The regulator distributes the running time among the compressor modules, taking into account the availability and number of running hours of each compressor module.

When the compressor has stopped automatically and the net pressure decreases, the regulator will start a compressor module before the net pressure has dropped to the starting pressure to prevent the net pressure from falling under the programmed minimum level.

### **1.5.2 Protecting the compressor**

If one or more compressor modules are shut down due to a protection function a warning message will be shown on the display.

The compressor will be shut down in case temperature switch (TSHH20-Fig. 2.8) trips. See also section 8.3.2.

#### **Warning**

Before carrying out any inspection or repair, stop the compressor, switch off the voltage, open the isolating switch and depressurize the compressor.

After remedying, switch on the voltage and press the key "Reset" (F3).

### **1.5.3 Monitoring components subject to service**

A number of service operations are grouped in plans (called Service plans I, A, B and D). Each Service plan has a programmed time interval. If a time interval is exceeded, a message will appear on the display to warn the operator to carry out the service actions belonging to that plan.

### **1.5.4 Automatic restart after voltage failure**

The regulator has a built-in function to automatically restart the compressor if the voltage is restored after voltage failure. For compressors leaving the factory, this function is made inactive. If desired, the function can be activated. Consult Atlas Copco.

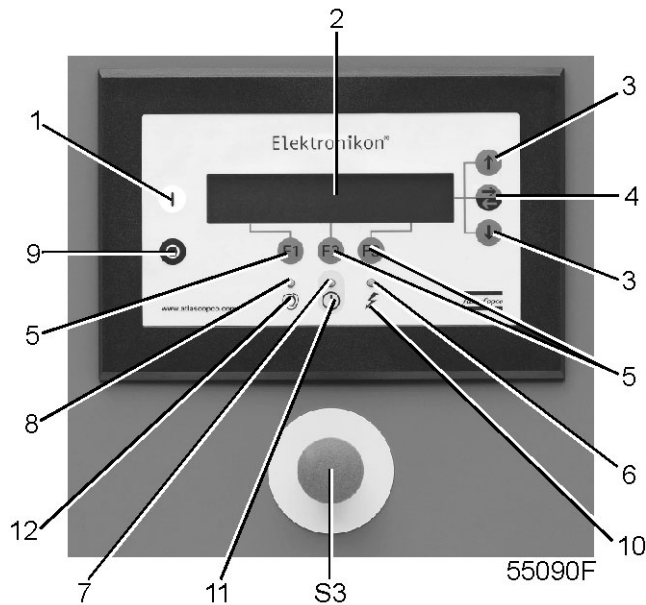

Fig. 1.11 Elektronikon regulator on SF Multi

### 1.5.5 Control panel (Fig. 1.11)

To control the compressor and to read and modify programmable parameters, the regulator is provided with a control panel including:

Ref	Designation	Function
1	Start button	Push button to start the compressor. LED (8) lights up indicating that the regulator is operative (in automatic operation).
2	Display	Indicates messages concerning the compressor operating condition, a service need or a fault.
3	Scroll keys	Keys to scroll through the display.
4	Tabulator key	Key to select the parameter indicated by a horizontal arrow. Only the parameters followed by an arrow pointing to the right are accessible for modifying.
5	Function keys	Keys to control and program the compressor.
6	Voltage on LED	Indicates that the voltage is switched on.
7	General alarm LED	Is a light in case of a warning condition, see section 8.3.
7	General alarm LED	Blinks in case of shut-down condition, if a sensor with shut-down function is out of order or after an emergency stop. See section 8.3.
8	Automatic operation LED	Indicates that the regulator is automatically controlling the compressor: the compressor is stopped and restarted depending on the air consumption and the limitations programmed in the regulator.
9	Stop button	Push button to stop the compressor. LED (8) goes out.
10	Pictograph	Voltage on.
11	Pictograph	Alarm condition.
12	Pictograph	Automatic operation.
S3	Emergency stop button	Push button to stop the compressor immediately in case of emergency. After remedying the trouble, unlock the button by pulling it out.

### 1.5.6 Display – keys

Compressor Outlet		7.0 bar
Compressor Running Menu		↓
F1	F2	F3

Fig. 1.12 Typical example of a display

#### Operating condition of a compressor module

The symbols shown above key F3 indicate the operating condition of each control module, see also section 8.1.2:

Symbol	Indicates
-	that the compressor module is available (ready to run), each symbol stands for a compressor module (the left symbol stands for the lowest mounted module, the right symbol stands for the highest module)
■	that the compressor module is running
- (blinking)	that the compressor module is not available (due to minimum stop time or too many starts)
* (blinking)	that the compressor module is shut-down

#### Scroll keys (3-Fig. 1.11)

These keys, labelled with vertical arrows, allow to scroll through the display.

As long as a downwards pointing arrow is shown at the utmost right position of the display, the key (3) with the same symbol can be used to see the next item.

As long as an upwards pointing arrow is shown at the utmost right position of the display, the key (3) with the same symbol can be used to see the previous item.

#### Tabulator key (4-Fig. 1.11)

This key, labelled with two horizontal arrows, allows the operator to go to the next field of the display, e.g. during modifying of programmable parameters.

### 1.5.7 Function keys (5-Fig. 1.11)

The keys are used:

- To call up or program settings
- To reset an active shut-down or service message, or an emergency stop
- To have access to all data collected by the regulator

The function keys allow to make the required selection from a menu of possibilities. The functions of the keys vary depending on the displayed menu. The actual function is abbreviated and indicated on the bottom line of the display just above the relevant key. Only the active and relevant functions at a moment are shown:

Designation	Function
Back	To return to a previously shown option or menu
Cancel	To cancel a programmed setting when programming parameters
Delete	To delete compressor start/stop commands
Extra	To find the module configuration of the regulator
Help	To find the Atlas Copco internet address
Limits	To show limits for a programmable setting
Mainscreen	To return from a menu to the main screen

Designation	Function
Menu	Starting from the main screen, to have access to submenus
Menu	Starting from a submenu, to return to a previous menu
Modify	To modify programmable settings
Program	To program modified settings
Reset	To reset a timer or message
Return	To return to a previously shown option or menu

### Selecting a menu

To facilitate controlling the compressor, menu-driven programs are implemented in the electronic module. Use the function keys (5) to select the menus in order to program and monitor the compressor. See also section 8.

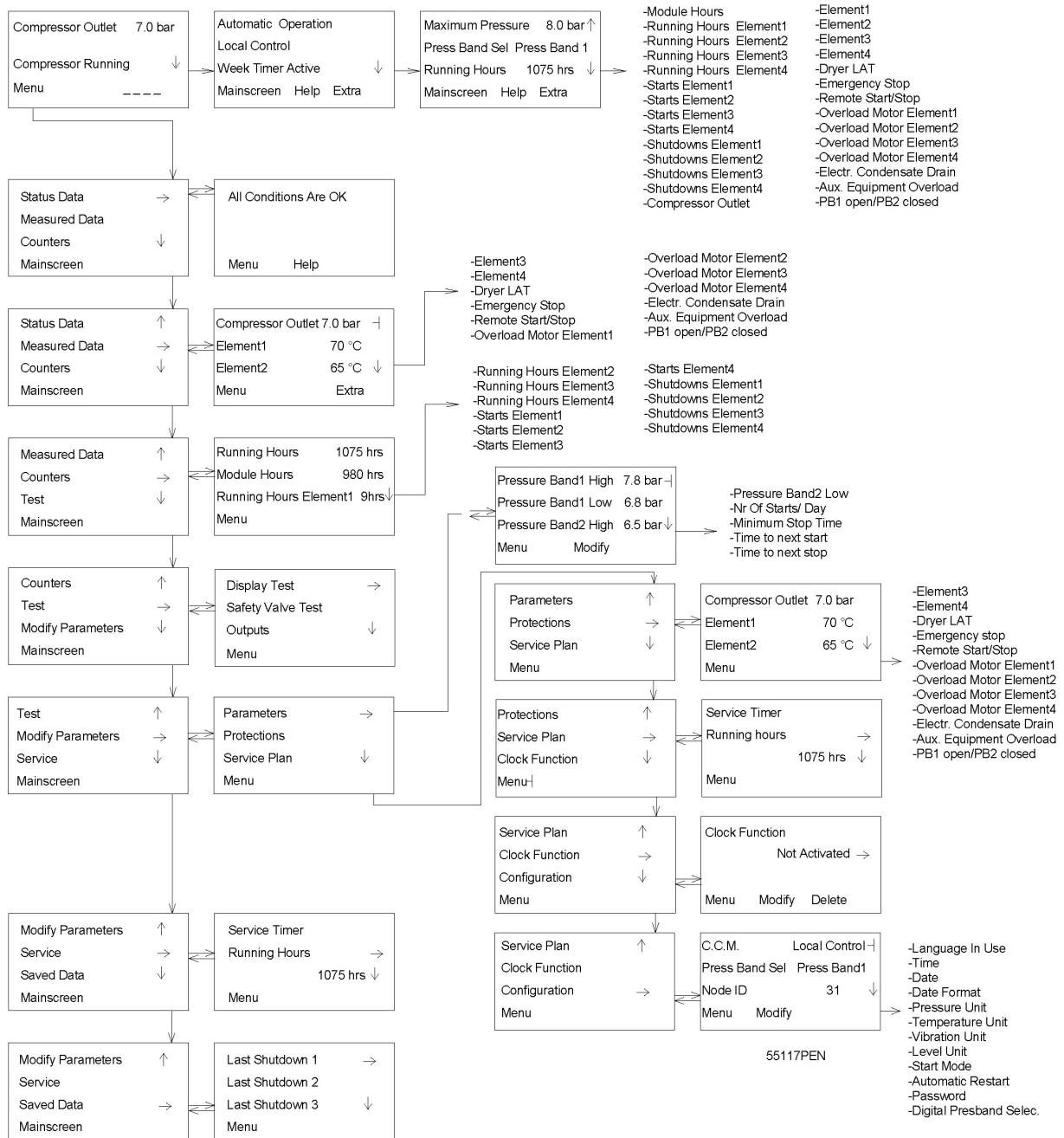
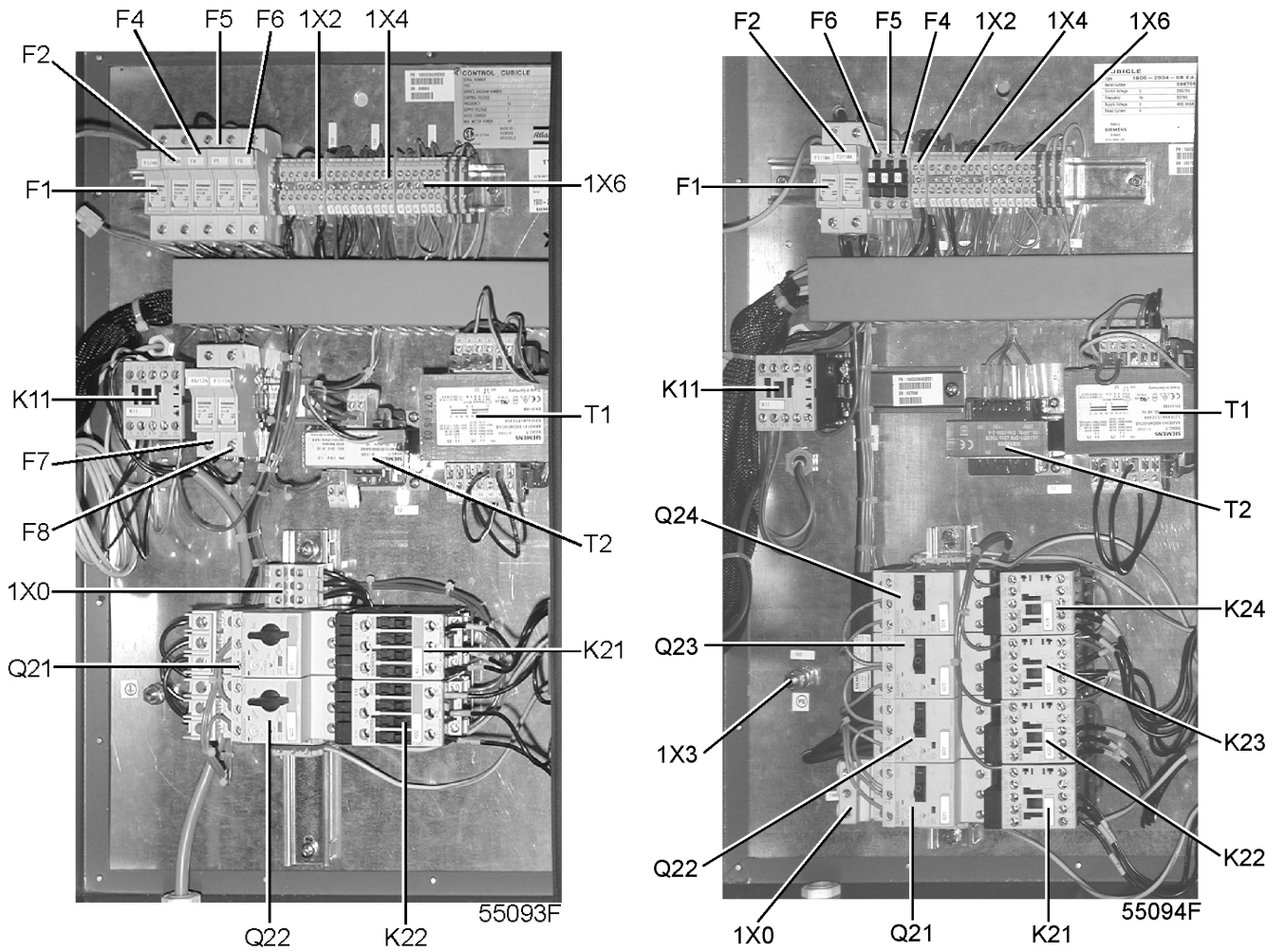

Fig. 1.13 Menu flow, SF Multi

### 1.6 Electric cabinet on SF Multi



- F1/8 Fuses
- K11 Auxiliary contactor, dryer
- K21/24 Contactors
- Q21/24 Circuit breakers
- T1/2 Transformers
- 1X0 Terminal strip, mains supply
- 1X2 Terminal strip, dryer
- 1X3/6 Terminal strips

Fig. 1.14 Electric cabinets, SF Multi

### 1.7 Air dryer on SF Full-Feature (Fig. 1.15)

#### Compressed air circuit

Wet compressed air enters heat exchanger (13) and is cooled by the outgoing, cold, dried air. Water in the incoming air starts to condense. The air then flows through heat exchanger (11) where the refrigerant evaporates and withdraws heat from the air. More water in the air condenses. The cold air then flows through condensate separator (3) where the condensate is separated from the air. The condensate is automatically drained through outlet (5). The cold, dried air then flows through heat exchanger (13), where it is warmed up by the incoming air.

#### Refrigerant circuit

Compressor (M1) delivers hot, high-pressure refrigerant gas which flows through condenser (9) where most of the refrigerant condenses.

The liquid flows through liquid refrigerant dryer/filter (12) to capillary tube (7). The refrigerant leaves the capillary tube at evaporating pressure.

The refrigerant enters evaporator (11) where it withdraws heat from the compressed air by further evaporation at constant pressure. The heated refrigerant leaves the evaporator and is sucked in by the compressor.

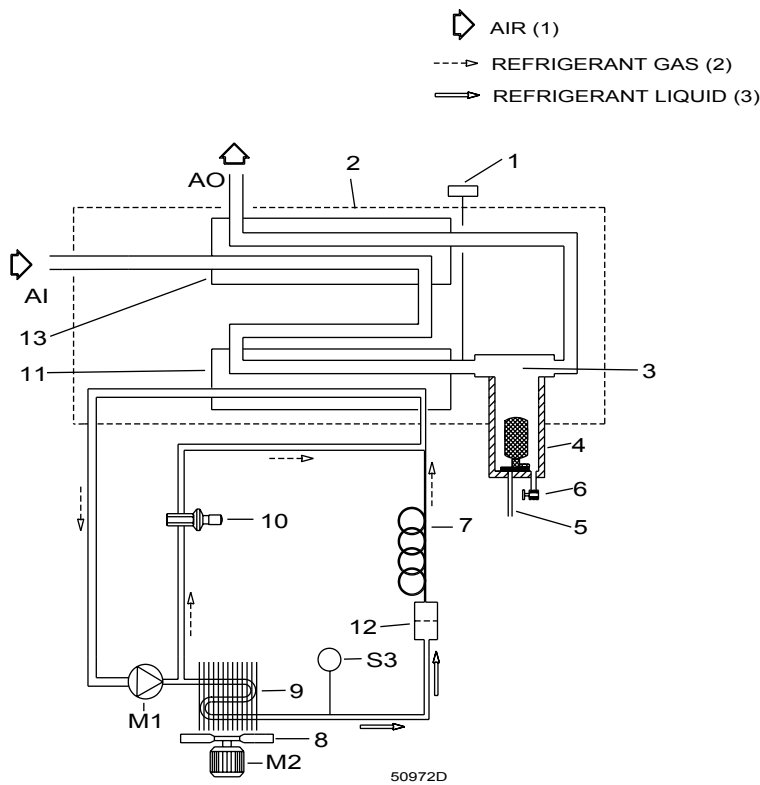

Text on Fig. 1.15

- (1) Air
- (2) Refrigerant gas
- (3) Refrigerant liquid

AI	Wet air inlet	5	Automatic condensate drain
AO	Dry air outlet	6	Manual condensate drain valve
M1	Refrigerant compressor	7	Capillary tube
M2	Condenser fan motor	8	Condenser cooling fan
S3	Fan control switch	9	Refrigerant condenser
1	Pressure dewpoint sensor	10	Hot gas by-pass valve
2	Insulating block	11	Air/refrigerant heat exchanger/evaporator
3	Condensate separator	12	Liquid refrigerant dryer/filter
4	Condensate trap	13	Air/air heat exchanger

Fig. 1.15 Dryer on SF Full-Feature



## 2 INSTALLATION

### 2.1 Dimension drawings (Figs. 2.1 up to 2.5)

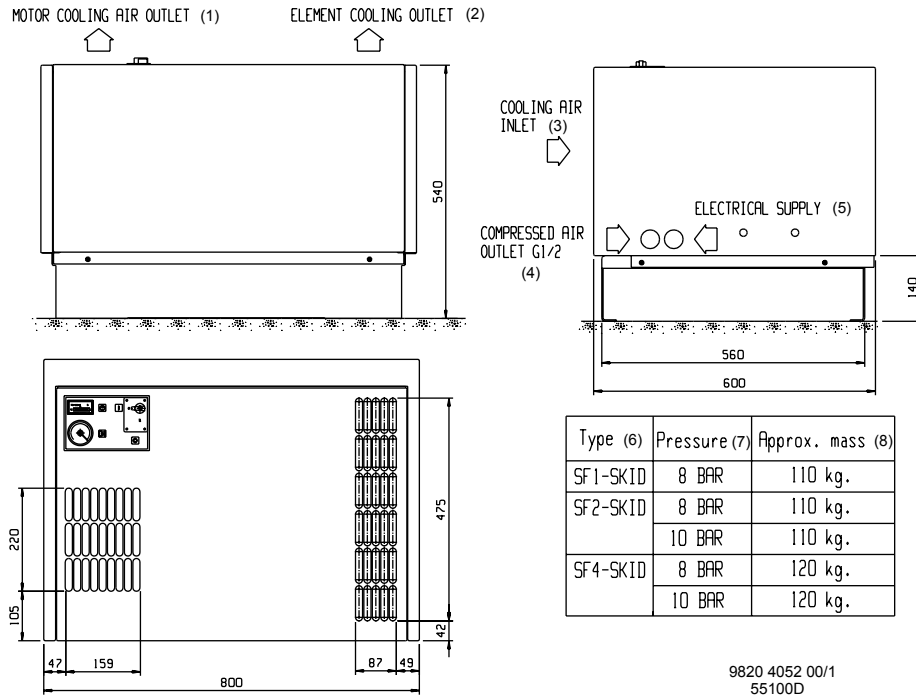

Fig. 2.1 Dimension drawing, SF 1-4 Skid

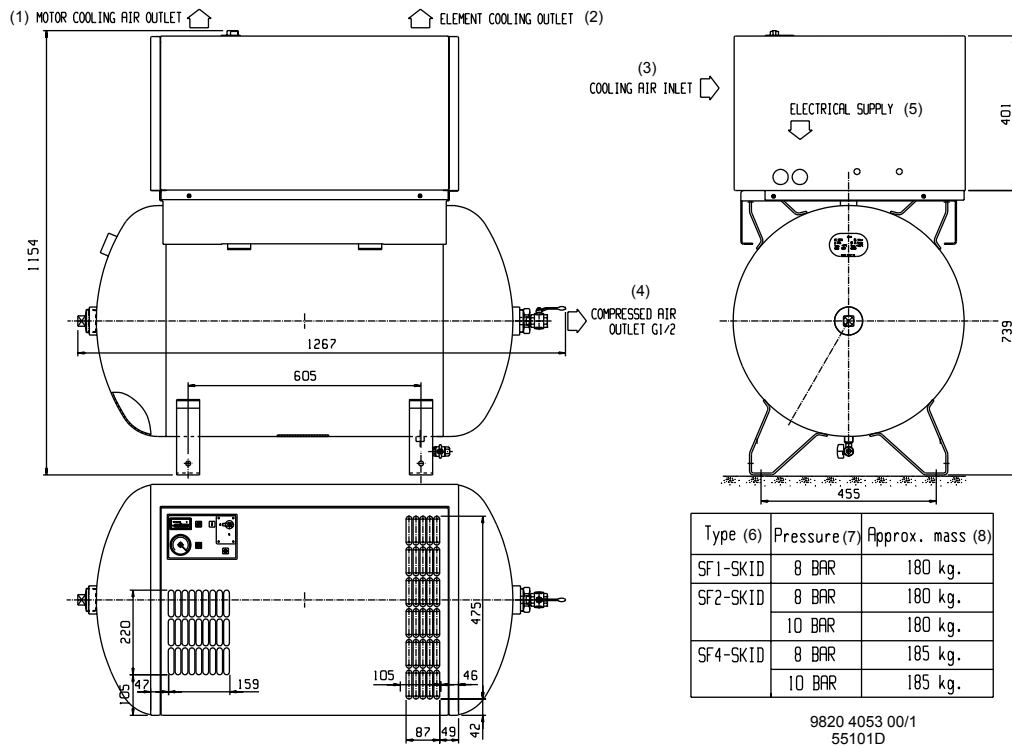

Fig. 2.2 Dimension drawing, SF 1-4 Tank-mounted

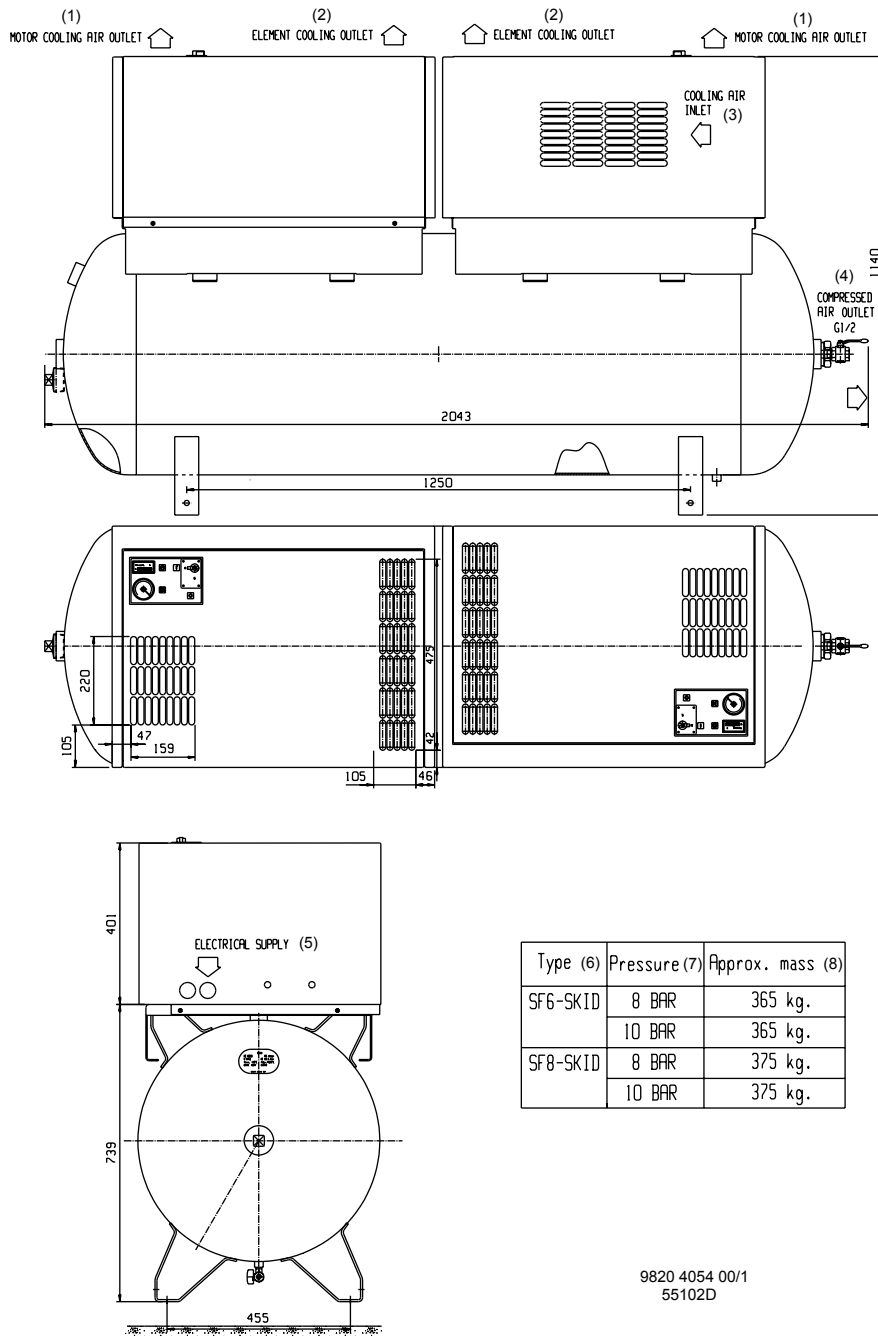
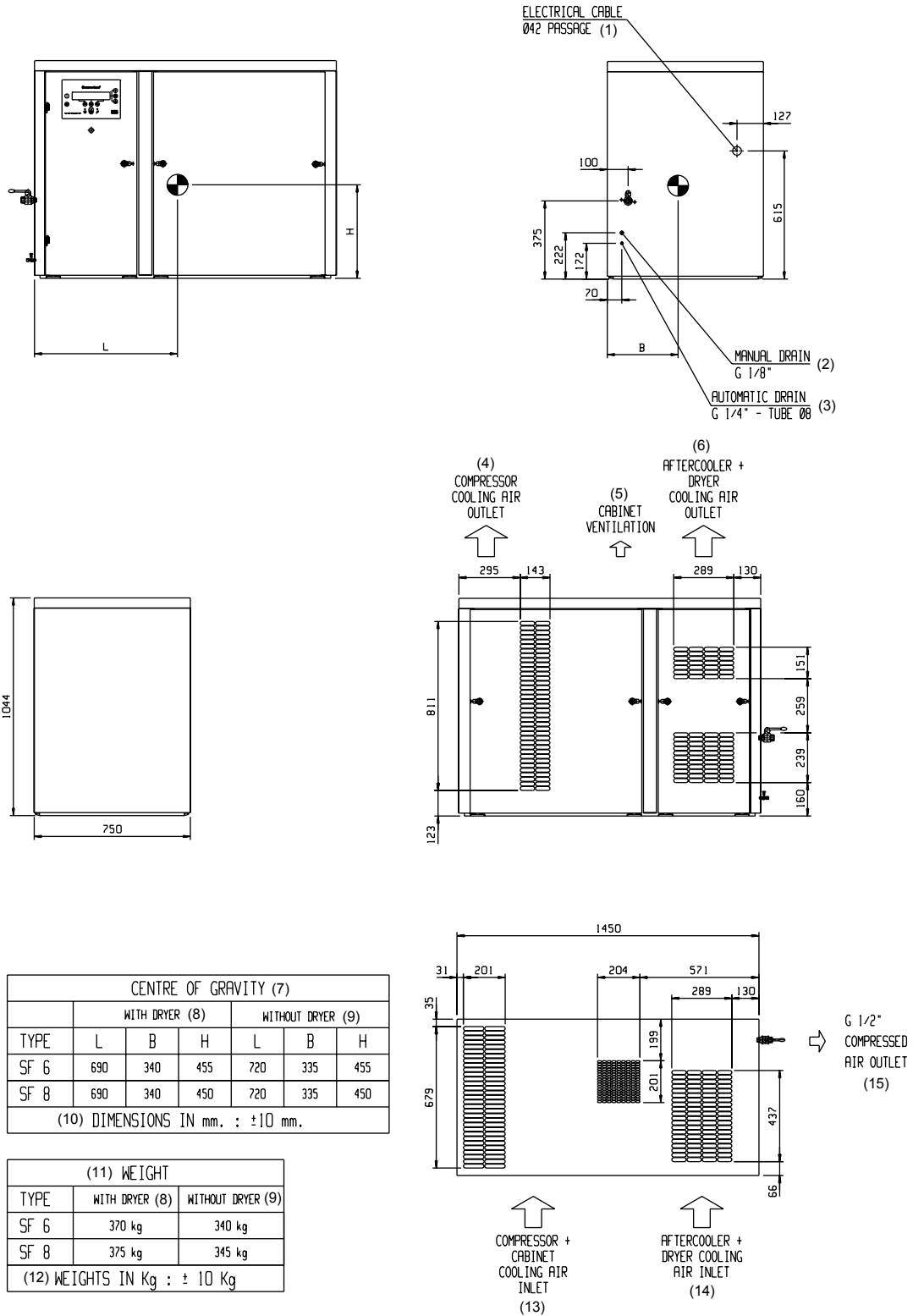

Fig. 2.3 Dimension drawing, SF 6-8 Twin

Text on Figs.2.1/2.3

- |   |                          |   |                   |
|---|--------------------------|---|-------------------|
| 1 | Motor cooling air outlet | 5 | Electrical supply |
| 2 | Element cooling outlet   | 6 | Type              |
| 3 | Cooling air inlet        | 7 | Pressure          |
| 4 | Compressed air outlet    | 8 | Mass, approx.     |



9820 4027 00  
55098D

Fig. 2.4 Dimension drawing, SF 6-8 Multi

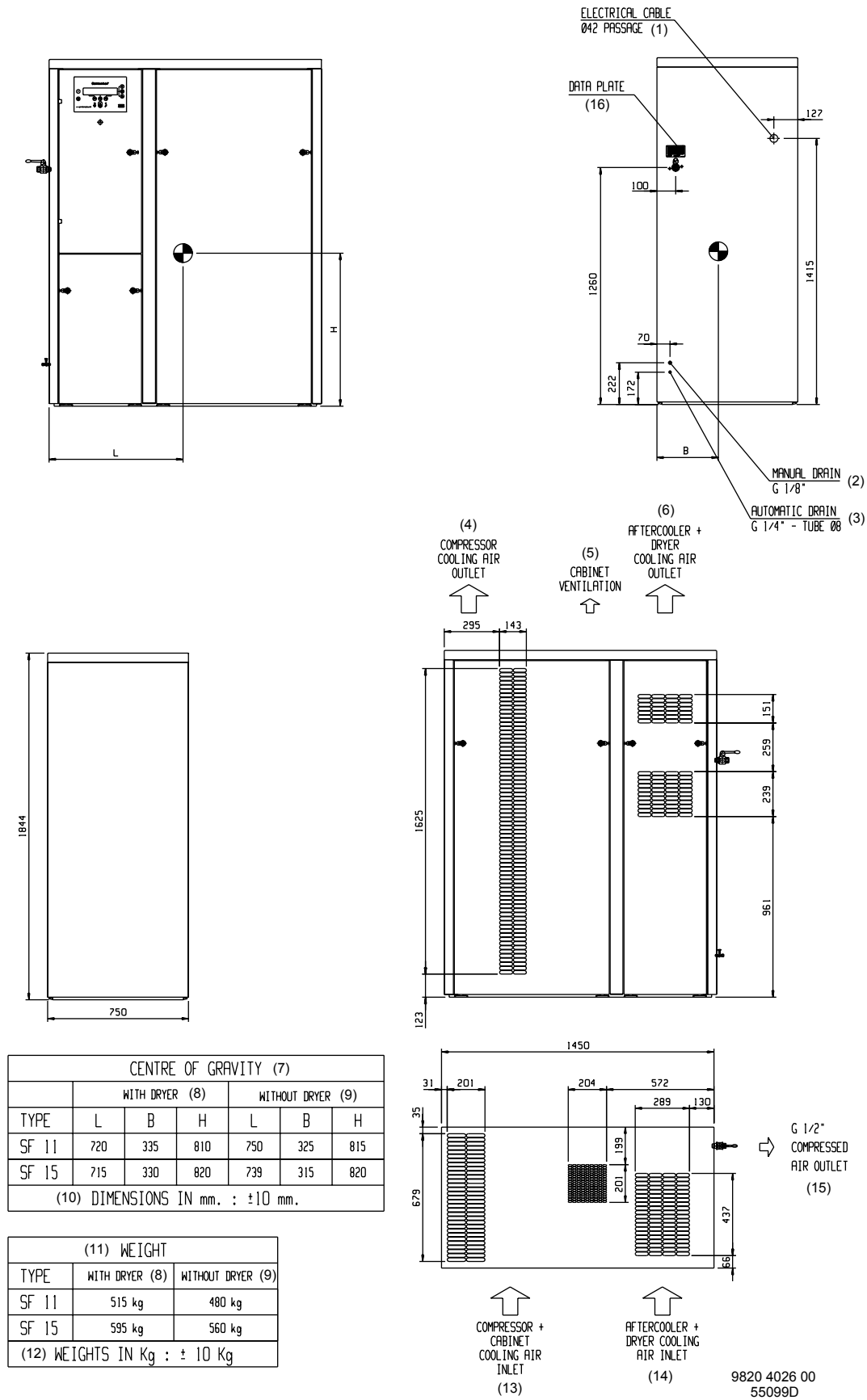

Fig. 2.5 Dimension drawing, SF 11-15 Multi

Text on Figs. 2.4/2.5

- (1) Electric cable
- (2) Manual drain
- (3) Automatic drain
- (4) Compressor cooling air outlet
- (5) Bodywork ventilation
- (6) Aftercooler and dryer cooling air outlet
- (7) Centre of gravity
- (8) With dryer
- (9) Without dryer
- (10) Dimensions +/- 10 mm
- (11) Weight
- (12) Weight +/- 10 kg
- (13) Compressor and bodywork cooling air inlet
- (14) Aftercooler and dryer cooling air inlet
- (15) Compressed air outlet
- (16) Data plate

## 2.2 Installation proposal (Fig. 2.6)

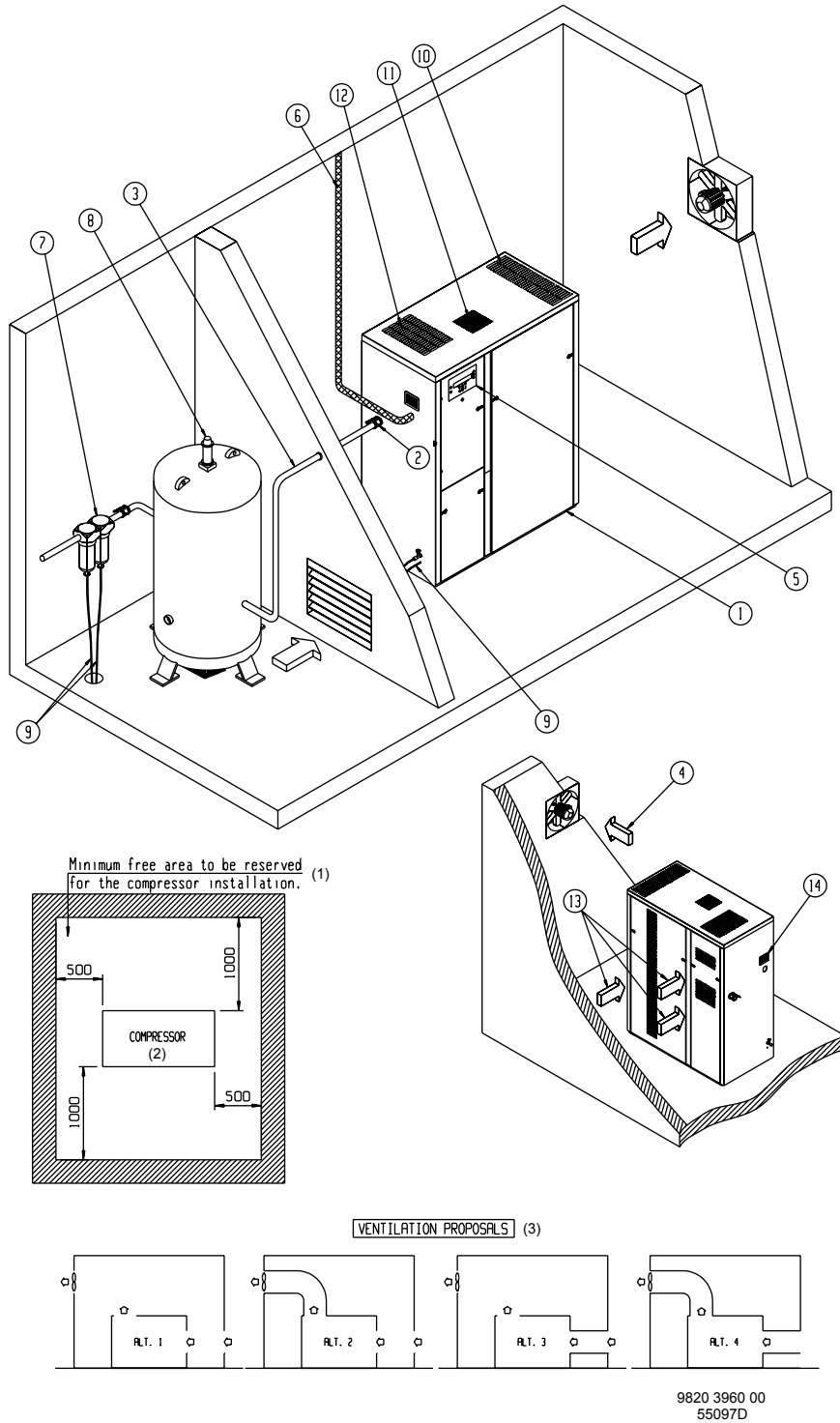

Fig. 2.6 Installation proposal, SF Multi

Text on Figs. 2.6

- (1) Minimum free area
- (2) Compressor
- (3) Ventilation proposals

1 Install the compressor on a level floor, in a cool but frost-free room which is well-ventilated. The air should be clean.

2 Position of compressed air outlet valve.

3 The maximum total pipe length can be calculated as follows:

$$L = (dP \times d^5 \times P) / (450 \times Qc^{1.85})$$

L = pipe length in m

dP = maximum allowable pressure drop (recommended 0.1 bar)

d = inner diameter of pipe in mm

P = compressor outlet pressure in bar absolute

Qc = free air delivery of compressor in l/s

4/13 Ventilation: the inlet grids and fan for compressor room ventilation should be installed in such a way that any recirculation of cooling air to the compressor or dryer is avoided. The air velocity to the grids must be limited to 5 m/s. The maximum allowable pressure drop over the cooling air ducts is 50 Pa. If this pressure drop is exceeded, a fan is needed at the outlet of the cooling air ducts. The maximum air temperature at the compressor intake opening is 40 °C.

For alternatives 1 and 3, the required ventilation capacity to limit the compressor room temperature can be calculated as follows:

$$Qv = 0.92 N/dT$$

Qv = required ventilation capacity in m<sup>3</sup>/s

N = shaft input of compressor in kW

dT= temperature increase in compressor room in °C

For alternatives 2 and 4, the fan capacity should match the compressor fan capacity at a pressure head equal to the pressure drop caused by the outlet cooling air ducts.

5 Position of control cubicle with monitoring panel.

6 Position of main cable entry. See section 7.1 for the recommended electric cables. See section 2.3 for connecting the power supply.

7 Optional filters can be installed in the pressure line downstream of the air outlet valve, e.g.: A DD filter for general-purpose filtration. The filter traps solid particles down to 1 micron. A PD filter for filtration down to 0.01 micron. A PD filter must be installed downstream of a DD filter. If odours are undesirable, a filter of the QD type should be installed downstream of the PD filter. It is recommended to install by-pass pipes to isolate the filters during servicing.

8 Safety valve.

9 Position of the drain flexibles. The flexibles towards the drain collector must not dip into the water of the drain collector.

10 Cooling air outlet, compressor elements.

11 Bodywork ventilation outlet.

12 Cooling air outlet, air cooler and dryer.

14 Data plate

## 2.3 Electrical connections

### General

The electrical installation must correspond to the local codes. The mains supply and earthing lines must be of suitable size. See section 7.1.

The installation must be earthed and protected by fuses in each phase. An isolating switch must be installed near the compressor. **Make sure that this switch is open to isolate the compressor from the mains before carrying out any connection.**

### Connections

#### Skid - Tank-mounted - Twin

Connect the cable to terminals 1 and 3 (single-phase) or to terminals 1, 3 and 5 (3-phase) of pressure switch (4-Fig. 1.10). Connect the earthing conductor to the earthing terminal. SF Twin have a pressure switch for each compressor module; provide for each pressure switch separate supply cables.

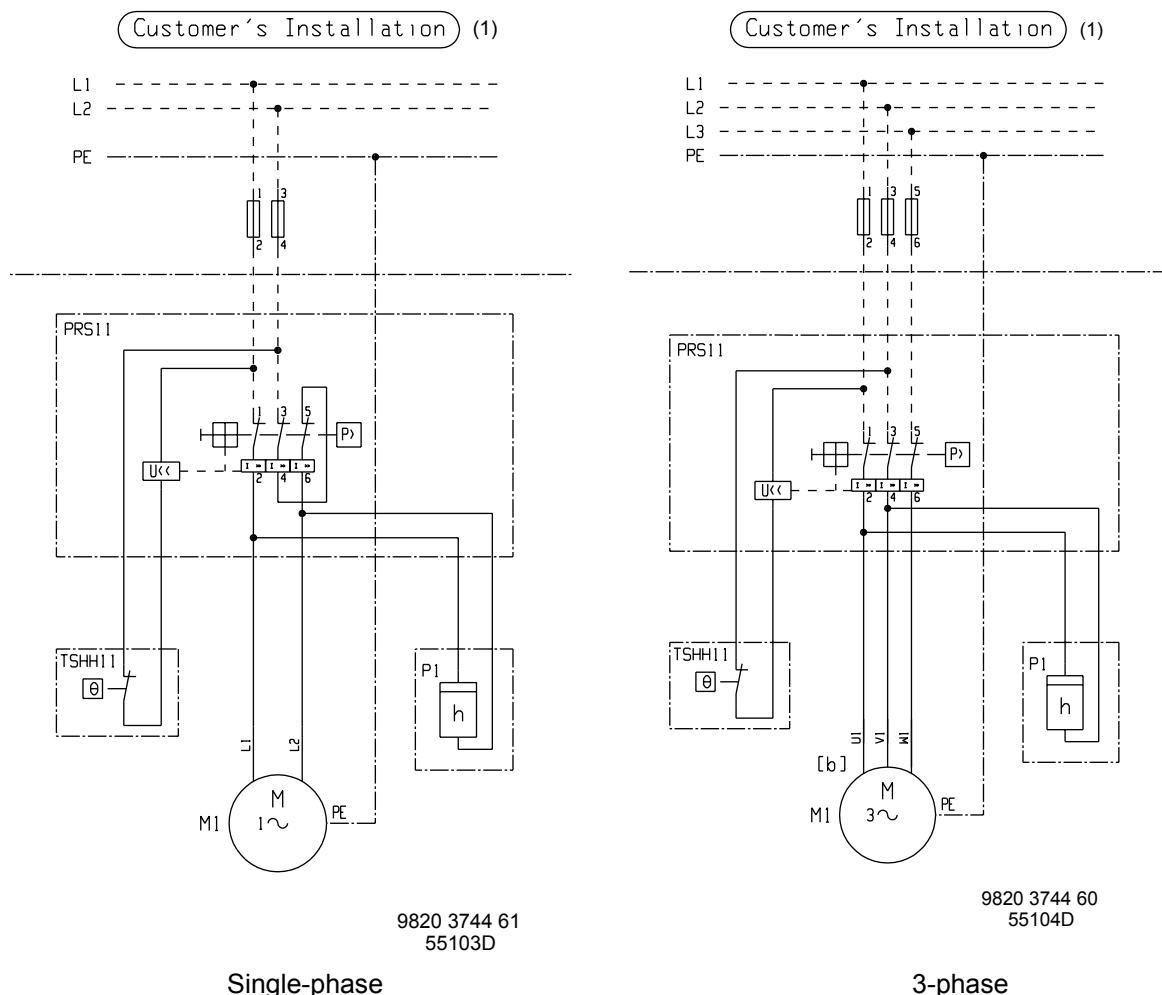

Fig. 2.7 Service diagram, SF Skid - Tank-mounted – Twin

Text on Fig. 2.7

(1) Customer's installation





A1	Dryer (optional)
F1/11	Fuses
K11	Auxiliary contactor, dryer
K21/24	Contactors
M1/4	Motors
M5	Fan motor, air cooler
M6	Fan motor, bodywork
PT20	Pressure sensor, air outlet
Q21/24	Circuit breakers
S3	Emergency stop button
TSHH20	Temperature switch, air outlet protection
TT11	Temperature sensor, compressor element 1 (lowest element)
TT12	Temperature sensor, compressor element 2
TT13	Temperature sensor, compressor element 3
TT14	Temperature sensor, compressor element 4 (highest element)
TT90	Temperature sensor, dewpoint temperature
T1/2	Transformers
1X0	Terminal strip, mains supply
1X2	Terminal strip, dryer
1X3/6	Terminal strips

Fig. 2.8 Service diagram for SF Multi

Text on Fig. 2.8

- (1) Customer's installation
- (2) Door
- (3) Higher voltage: Y  
Lower voltage: D
- (4) Dryer
- (5) Optional
- (6) Supply of dryer
- (7) All other voltages
- (8) Marking of connectors 2X5 to 2X12
- (9) Pressure transducer: pin configuration
- (10) Temperature sensor, element 1
- (11) Temperature sensor, element 2
- (12) Temperature sensor, element 3
- (13) Temperature sensor, element 4
- (14) Temperature sensor, LAT dryer
- (15) Pressure transducer, delivery air
- (16) Temperature switch, delivery air
- (17) FF only
- (18) Emergency stop
- (19) Remote start/ pr. Stop
- (20) Overload motor M1
- (21) Overload motor M2
- (22) Overload motor M3
- (23) Overload motor M4
- (24) Fault EWD
- (25) High temperature outlet
- (26) Remote pressure set point  
Selection: Open = set 1 Closed = set 2
- (27) Remote emergency stop
- (28) Auxiliary contacts

## 2.4 Pictographs

Fig. 2.9 shows examples of pictographs which may be used on the machine.

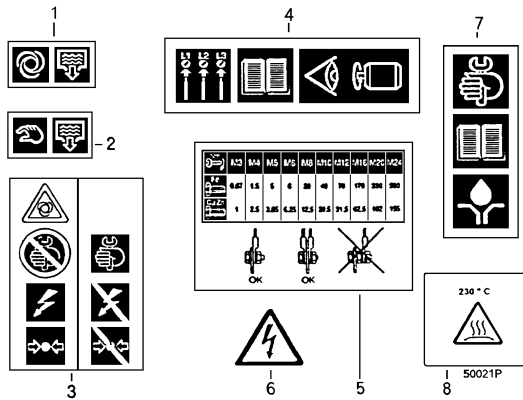

- 1 Automatic condensate drain
- 2 Manual condensate drain
- 3 Switch off voltage and depressurize compressor before maintenance or repair
- 4 Before connecting compressor electrically, consult Instruction book for motor rotation direction
- 5 Torques for steel (Fe) or brass (CuZn) bolts
- 6 Warning, voltage
- 7 Consult Instruction book before greasing
- 8 Warning, hot hose

Fig. 2.9 Pictographs

## 3 OPERATING INSTRUCTIONS

### Safety precautions

The operator must apply all relevant safety precautions, including those mentioned in this book.

### Outdoor/altitude operation

If the compressor is installed outdoors or if the air inlet temperature can be below 0 °C, precautions must be taken. In this case, and also if operating at high altitude, consult Atlas Copco.

### Before initial start-up

For SF Multi read section 8 to familiarize yourself with all regulator functions.

### 3.1 Initial start-up

1. Remove the red painted transport brackets:
  - for SF Multi remove brackets (2-Fig. 5.1)
  - for the other variants remove the brackets (one on each side of the frame)
2. For SF Multi check the settings of the overload relays (Q21, -22, -23, -24 - Fig. 1.14).
3. Connect the compressor electrically. See section 2.3.
4. Close the condensate drain valve: valve (1-Fig. 1.9 on SF Multi) or the valve underneath the air receiver, if provided.
5. Switch on the voltage. Start and stop the compressor. On 3-phase compressors, check for correct direction of rotation (arrows are provided on the motors). If the rotation direction is wrong, switch off the voltage and reverse two incoming electric lines.

### 3.2 Starting

#### 3.2.1 Multi

1. Open air outlet valve (3-Figs. 1.5/1.6).
2. Switch on the voltage.
3. Close condensate drain valve (1-Fig. 1.9).
4. Press start button (1-Fig. 1.11). The compressor starts running and automatic operation LED (8-Fig. 1.11) lights up.
5. The regulator will automatically stop and start compressor modules, depending on the air pressure.
6. **On SF Full-Feature**, the nominal pressure dewpoint will be reached after a few minutes.

#### 3.2.2 Skid - Tank-mounted - Twin

1. Open air outlet valve (2-Figs. 1.2/1.4).
2. Switch on the voltage.
3. Check that the condensate drain valve underneath the air receiver (if installed) is closed.
4. Move switch (2-Fig. 1.10) to AUTO. The compressor starts running.
5. The drive motor(s) will automatically stop and start, depending on the air pressure.

**Note:** The maximum number of compressor starts is 30 per hour.

### **3.3 During operation**

#### **3.3.1 Multi**

1. If the automatic operation LED (8-Fig. 1.11) is alight, the regulator is automatically controlling the compressor modules (starting/stopping).
2. Check the readings on display (2-Fig. 1.11). In case of a warning or shut-down condition, see section 8.3.
3. Check that condensate is discharged automatically from outlet (2-Figs. 1.9) during running.

**Note:** The dewpoint will deviate from nominal when the nominal conditions are exceeded. If the dewpoint remains too high or unstable, consult section 6.

#### **3.3.2 Skid - Tank-mounted - Twin**

1. Check the starting and stopping pressures (1-Fig. 1.10).
2. Regularly open the drain valve underneath the air receiver for a few seconds, close the valve after draining.

### **3.4 Stopping**

#### **3.4.1 Multi**

1. Press stop button (9-Fig. 1.11).
2. Close air outlet valve (3-Figs. 1.5/1.6).
3. Switch off the voltage.
4. Open condensate drain valve (1-Fig. 1.9).

#### **3.4.2 Skid - Tank-mounted - Twin**

1. Move switch (2-Fig. 1.10) to OFF.
2. Close air outlet valve (2-Figs. 1.2/1.4).
3. Switch off the voltage.
4. Open the condensate drain valve underneath the air receiver (if provided) for a few seconds, close the valve after draining.

### **3.5 Taking out of operation at end of compressor service life**

1. Stop the compressor and close the air outlet valve.
2. Switch off the voltage and disconnect the compressor from the mains.
3. Open the condensate drain valve. Depressurize the compressor
4. Shut off and depressurize the part of the air net which is connected to the outlet valve. Disconnect the compressor from the air net.
5. Disconnect the condensate piping from the local condensate drain system.

## 4 MAINTENANCE

### **Before carrying out any maintenance or repair:**

1. Stop the compressor, switch off the voltage and open the isolating switch.
2. Close the air outlet valve (2-Figs. 1.2/1.4 or 3-Figs. 1.5/1.6) and open the manual drain valve: valve (1-Fig. 1.9) on Multi or the valve underneath the air receiver, if provided.

### **4.1 Compressor drive motors**

The motor bearings are greased for life.

### **4.2 Preventive maintenance schedule for the compressor**

The schedule comprises a summary of the maintenance instructions. Read the respective section before taking maintenance measures. The "longer interval" checks must also include the "shorter interval" checks.

Carry out the service operations at the period or running hours mentioned below, whichever interval comes first.

When servicing, replace all disengaged packings, e.g. gaskets, O-rings, washers.

#### **Important**

Use only authorized parts. Any damage or malfunction by the use of unauthorized parts is not covered by Warranty or Product Liability.

#### **Service plans on SF Multi**

A number of service operations are grouped in plans, called Service plans I, A, B or D; see the schedule below.

Each plan has a programmed time interval at which all service actions belonging to that plan are to be carried out.

When reaching the interval, a message will appear on the screen indicating which Service plans are to be carried out. After servicing, the intervals are to be reset. For detailed information, consult section 8.3.

#### **Important**

Always consult Atlas Copco in case any timer setting should be changed.

Period	Running hours	Service Plan	See section	See notes below table	Operation
<b>Daily</b>	--	--	3.4	--	Drain condensate
"	--	--	--	--	On SF Full-Feature, check dewpoint
<b>Monthly</b>	250	--	5.1	1	Inspect air filter
<b>3-monthly</b>	500	--	--	--	Check pressure drop over Atlas Copco filters (optional)
<b>6-monthly</b>	--	--	5.4	--	Operate safety valve
"	--	--	--	--	Clean compressor
"	--	--	--	--	On SF Full-Feature, brush or blow off the finned surface of the condenser
"	--	--	--	--	On SF Full-Feature, clean condensate trap internally
<b>Yearly</b>	--	--	5.4	--	Test safety valve
"	--	--	--	--	Have electrical components/shut-down switch tested
"	2500	<b>I</b>	5.2	--	Check tension/condition of V-belt(s)
"	5000	<b>A</b>	5.1	--	Replace air filter
"	5000	<b>A</b>	--	2	Have ball valve mechanism of condensate trap inspected
"	5000	<b>A</b>	5.2	--	Replace V-belt(s)
<b>2-yearly</b>	5000	<b>B</b>	--	2	Have orbiting scroll bearing greased
"	10000	<b>B</b>	--	2	Clean compressor element fan and duct. Clean compressor element fins, have seals replaced
"	10000	<b>B</b>	--	2	Have pin crank bearings greased

**Notes:**

1. Check more frequently if operating in a dusty atmosphere. Check for cleanness and damage. Replace a dirty or damaged filter by a new one.
2. Consult Atlas Copco.

## 5 ADJUSTMENTS AND SERVICING PROCEDURES

### 5.1 Air filter (1-Figs. 1.7/1.8)

1. Stop the compressor. Remove the filter cover and filter.
2. Clean the cover, if necessary. Discard damaged filters.
3. Fit a new filter and reinstall the cover.

### 5.2 Belt exchange/tensioning (Fig. 5.1)

**In case of two belts, the belts must be replaced as a set, even if only one of them seems worn. Use Atlas Copco belts only.** The part number of the belt set is mentioned in the Parts list.

1. Loosen motor hold-down bolts (3).
2. Loosen the belt tension by screwing bolts (4) equally and take out the belts.
3. Install new belts in the grooves of the pulleys.
4. Tension the belts by screwing bolts (4) equally. The tension is correct if the deflection is between 5 mm and 7 mm when exerting a force of 25 N on the belt midway between the pulleys. Make sure that the pulleys remain aligned. The maximum out-of-line is:
  - maximum parallel out-of-line: 0.5 mm
  - maximum angular out-of-line: 0.5 degrees
5. Tighten bolts (3).
6. Check the belt tension after the first 500 running hours.

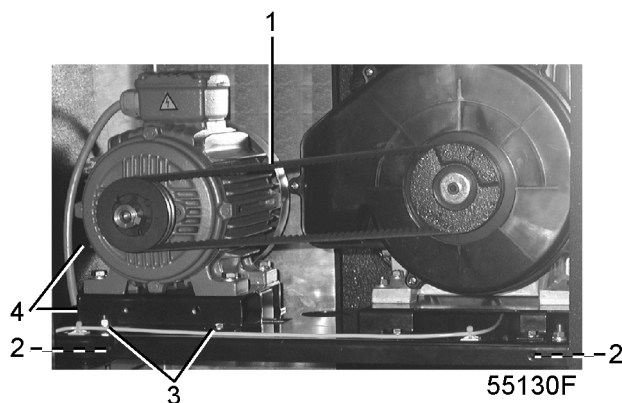

- |   |   |
|---|---|
| 1 | Belts                                   |
| 2 | Transport brackets (2x - to be removed) |
| 3 | Motor hold-down bolts (4x)              |
| 4 | Tensioning bolt                         |

Fig. 5.1 Belt tensioning / transport fixation

### 5.3 Coolers

Keep the coolers clean to maintain cooling efficiency.

Remove any dirt from the coolers with a fibre brush. Never use a wire brush or metal objects. Then clean by air jet in reverse direction of normal flow. If it should be necessary to wash the coolers with a cleansing agent, consult Atlas Copco.



## 5.4 Safety valve

### **Operating**

Operate the safety valve by unscrewing the knurled cap one or two turns. Retighten the cap.

### **Testing**

The valve can be tested on a separate compressed air line. If the valve does not open at the pressure marked on the valve, consult Atlas Copco.

### **Warning**

No adjustments are allowed. Never run the compressor without safety valve.

## 6 PROBLEM SOLVING

### Before carrying out any maintenance or repair:

1. Stop the compressor, switch off the voltage and open the isolating switch.
2. Close the air outlet valve (2-Figs. 1.2/1.4 or 3-Figs. 1.5/1.6) and open the manual drain valve: valve (1-Fig. 1.9) on Multi or the valve underneath the air receiver, if provided.

<b>1</b>	<b>Compressor does not start</b>
a	Loose connection
a	Have electrical connections checked
b	Receiver pressure too high
b	Compressor will start when the net pressure drops to the minimum pressure
<b>2</b>	<b>Safety valve blows</b>
a	Safety valve opens too soon
a	Replace valve
<b>3</b>	<b>Compressor capacity or pressure below normal</b>
a	Air consumption exceeds capacity of compressor
a	Check equipment connected
b	Choked air filter
b	Remove and check filter. Replace if necessary
c	Safety valve leaking
c	Replace valve
d	Drive belt(s) slipping
d	Check condition of belt(s). Correct or replace as required
<b>4</b>	<b>Compressor module overheating / compressor shut down by its air temperature switch</b>
a	Insufficient compressor cooling
a	Improve ventilation of compressor room.
b	Cooling fan out of order
b	Check and correct
	<b>On SF Full-Feature also:</b>
<b>5</b>	<b>Pressure dewpoint too high</b>
a	Shortage of refrigerant
a	Have circuit repaired or recharged
b	Refrigerant compressor does not run
b	See 7
c	Condenser pressure is too high
c	See 6
<b>6</b>	<b>Condenser pressure too high or too low</b>
a	Fan control switch out of order
a	Have switch replaced
b	Condenser fan motor out of order
b	Have fan motor inspected
c	Ambient temperature too high
c	Improve ventilation. If necessary, draw the cooling air from a cooler room
d	Condenser externally clogged
d	Clean condenser
<b>7</b>	<b>Motor of refrigerant compressor stops or does not start</b>
a	Thermal protection of the motor has tripped
a	Compressor will restart when the motor windings have cooled down

## 7 PRINCIPAL DATA

### 7.1 Electric cable size for SF1-8

Frequency	Voltage	SF1 single- phase	SF2 single- phase	SF2 3-phase	SF4 3-phase	SF6 3-phase	SF8 3-phase
<b>IEC</b>							
50 Hz	230 V	2.5 mm <sup>2</sup>	2.5 mm <sup>2</sup>	2.5 mm <sup>2</sup>	2.5 mm <sup>2</sup>	2x 2.5 mm <sup>2</sup>	2x 2.5 mm <sup>2</sup>
50 Hz	400 V			2.5 mm <sup>2</sup>	2.5 mm <sup>2</sup>	2x 2.5 mm <sup>2</sup>	2x 2.5 mm <sup>2</sup>
60 Hz	380 V			2.5 mm <sup>2</sup>	2.5 mm <sup>2</sup>	2x 2.5 mm <sup>2</sup>	2x 2.5 mm <sup>2</sup>
50 Hz	500 V			2.5 mm <sup>2</sup>	2.5 mm <sup>2</sup>	2x 2.5 mm <sup>2</sup>	2x 2.5 mm <sup>2</sup>
<b>CSA/UL</b>							
60 Hz	200/230 V	AWG 12	AWG 12	AWG 12	AWG 10	2x AWG 12	2x AWG 10
60 Hz	440/460 V			AWG 12	AWG 12	2x AWG 12	2x AWG 12

### 7.2 Electric cable size for SF 6-15 Multi

Frequency	Voltage	SF6 3-phase	SF8 3-phase	SF11 3-phase	SF15 3-phase
<b>IEC</b>					
50 Hz	230 V	6 mm <sup>2</sup>	10 mm <sup>2</sup>	16 mm <sup>2</sup>	25 mm <sup>2</sup>
50 Hz	400 V	4 mm <sup>2</sup>	6 mm <sup>2</sup>	10 mm <sup>2</sup>	10 mm <sup>2</sup>
60 Hz	380 V	4 mm <sup>2</sup>	6 mm <sup>2</sup>	10 mm <sup>2</sup>	10 mm <sup>2</sup>
50 Hz	500 V	2.5 mm <sup>2</sup>	4 mm <sup>2</sup>	6 mm <sup>2</sup>	10 mm <sup>2</sup>
<b>CSA/UL</b>					
60 Hz	200/230 V	AWG 8	AWG 6	AWG 4	AWG 3
60 Hz	440/460 V	AWG 10	AWG 10	AWG 8	AWG 6
60 Hz	575 V	AWG 12	AWG 10	AWG 8	AWG 6

### 7.3 Overload relays for SF1-8

Frequency	Voltage	SF1 single- phase	SF2 single- phase	SF2 3-phase	SF4 3-phase	SF6 3-phase	SF8 3-phase
<b>IEC</b>							
50 Hz	230 V	12 A	14.5 A	8.3 A	14 A	8.3 and 14 A	2x 14 A
50 Hz	400 V			4.8 A	8.2 A	4.8 and 8.2 A	2x 8.2 A
60 Hz	380 V			5.1 A	8.5 A	5.1 and 8.5 A	2x 8.5 A
50 Hz	500 V			3.8 A	6.5 A	3.8 and 6.5 A	2x 6.5 A
<b>CSA/UL</b>							
60 Hz	230 V	10.2 A	14.7 A	9.2 A	15.3 A	9.2 and 15.3 A	2x 15.3 A
60 Hz	440/460 V			4.6 A	7.7 A	4.6 and 7.7 A	2x 7.7 A

**Note:** SF6 Twin have compressor modules of a different size, the first value is valid for the smaller SF2 module and the second one is valid for the bigger SF4 module

### 7.4 Overload relays for SF6-15 Multi

Frequency	Voltage	SF6 3-phase	SF8 3-phase	SF11 3-phase	SF15 3-phase
<b>IEC</b>					
50 Hz	230 V	8 and 14 A	2x 14 A	3x 14 A	4x 14 A
50 Hz	400 V	4.8 and 8 A	2x 8 A	3x 8 A	4x 8 A
60 Hz	380 V	5 and 8.5 A	2x 8.5 A	3x 8.5 A	4x 8.5 A
50 Hz	500 V	3.6 and 6.4 A	2x 6.4 A	3x 6.4 A	4x 6.4 A
<b>CSA/UL</b>					
60 Hz	230 V	9 and 15 A	2x 15 A	3x 15 A	4x 15 A
60 Hz	440/460 V	4.5 and 7.5 A	2x 7.5 A	3x 7.5 A	4x 7.5 A
60 Hz	575 V	3.5 and 5.5 A	2x 5.5 A	3x 5.5 A	4x 5.5 A

**Note:** SF6 have compressor modules of a different size, the first value is valid for the smaller SF2 module (lower element) and the second one is valid for the bigger SF4 module (higher element)

### 7.5 Main fuses for SF1-8

Frequency	Voltage	SF1 single- phase	SF2 single- phase	SF2 3-phase	SF4 3-phase	SF6 3-phase	SF8 3-phase
<b>IEC</b>							
50 Hz	230 V	20 A	20 A	20 A	20 A	2x 20 A	2x 20 A
50 Hz	400 V			20 A	20 A	2x 20 A	2x 20 A
60 Hz	380 V			20 A	20 A	2x 20 A	2x 20 A
50 Hz	500 V			20 A	20 A	2x 20 A	2x 20 A
<b>CSA/UL</b>							
60 Hz	230 V	25 A	25 A	20 A	30 A	20 A	2x 30 A
60 Hz	440/460 V			15 A	15 A	15 A	2x 15 A

### 7.6 Main fuses for SF6-15 Multi

Frequency	Voltage	SF6 3-phase	SF8 3-phase	SF11 3-phase	SF15 3-phase
<b>IEC</b>					
50 Hz	230 V	32 A	50 A	63 A	80 A
50 Hz	400 V	25 A	32 A	50 A	50 A
60 Hz	380 V	25 A	32 A	50 A	50 A
50 Hz	500 V	20 A	25 A	32 A	50 A
<b>CSA/UL</b>					
60 Hz	230 V	45 A	60 A	80 A	110 A
60 Hz	440/460 V	25 A	30 A	45 A	60 A
60 Hz	575 V	20 A	25 A	35 A	45 A

### 7.7 Reference conditions/limitations

<b>Reference conditions:</b>	
Air inlet pressure (absolute)	1 bar
Air inlet temperature	20 °C
Relative air humidity	0%
Nominal working pressure	See values below
<b>Limitations</b>	
Max. working pressure	See values below
Max. ambient temperature	40 °C
Min. ambient temperature	0 °C

### 7.8 SF1-4 8bar 50 Hz 1)

Compressor type		SF1	SF2	SF4
		<b>8 bar</b>	<b>8 bar</b>	<b>8 bar</b>
Maximum working pressure	bar(e)	8	8	8
Nominal working pressure	bar(e)	7	7	7
Air temperature at outlet valve (Tank-mounted/Twin), approx.	°C	30	32	40
Air temperature at outlet valve (Skid), approx.	°C	38	45	65
Motor shaft speed	r/min	2885	2885	2885
Shaft input	kW	1.5	2.1	3.4
Sound pressure level	dB(A)	65	67	68

### 7.9 SF2-4 10 bar 50 Hz 1)

Compressor type		SF2	SF4
		<b>10 bar</b>	<b>10 bar</b>
Maximum working pressure	bar(e)	10	10
Nominal working pressure	bar(e)	10	10
Air temperature at outlet valve (Tank-mounted/Twin), approx.	°C	28	40
Air temperature at outlet valve (Skid), approx.	°C	45	65
Motor shaft speed	r/min	2885	2885
Shaft input	kW	2.1	3.65
Sound pressure level	dB(A)	67	68

### 7.10 SF1-4 100 psi 60 Hz 1)

Compressor type		SF1	SF2	SF4
		<b>100 psi</b>	<b>100 psi</b>	<b>100 psi</b>
Maximum working pressure	bar(e)	8	8	8
Nominal working pressure	bar(e)	7	7	7
Air temperature at outlet valve (Tank-mounted/Twin), approx.	°C	30	32	40
Air temperature at outlet valve (Skid), approx.	°C	38	45	65
Motor shaft speed	r/min	1710	3485	3485
Shaft input	kW	1.5	2.1	3.4
Sound pressure level	dB(A)	65	67	68

### 7.11 SF2-4 145 psi 60 Hz 1)

Compressor type		SF2	SF4
		<b>145 psi</b>	<b>145 psi</b>
Maximum working pressure	bar(e)	10	10
Nominal working pressure	bar(e)	10	10
Air temperature at outlet valve (Tank-mounted/Twin), approx.	°C	28	40
Air temperature at outlet valve (Skid), approx.	°C	45	65
Motor shaft speed	r/min	3485	3485
Shaft input	kW	2.1	3.65
Sound pressure level	dB(A)	67	68

### 7.12 SF6-15 Multi 8 bar 50 Hz 1)

<b>Compressor type</b>		<b>SF6</b>	<b>SF8</b>	<b>SF11</b>	<b>SF15</b>
		<b>8 bar</b>	<b>8 bar</b>	<b>8 bar</b>	<b>8 bar</b>
Maximum working pressure for SF Pack	bar(e)	8	8	8	8
Maximum working pressure for SF Full-Feature	bar(e)	7.75	7.75	7.75	7.75
Nominal working pressure	bar(e)	7	7	7	7
Air temperature at outlet valve for SF Pack, approx.	°C	26	28	30	32
Air temperature at outlet valve for SF Full-Feature, approx.	°C	23	25	25	25
Motor shaft speed	r/min	2885	2885	2885	2885
Shaft input	kW	5.6	6.9	10.4	13.8
Sound pressure level	dB(A)	61	62	60	63
<b>For SF Full-Feature also:</b>					
Refrigerant type		R134a	R134a	R134a	R134a
Pressure dewpoint, approx 2)	°C	3	3	3	3

### 7.13 SF6-15 Multi 10 bar 50 Hz 1)

<b>Compressor type</b>		<b>SF6</b>	<b>SF8</b>	<b>SF11</b>	<b>SF15</b>
		<b>10 bar</b>	<b>10 bar</b>	<b>10 bar</b>	<b>10 bar</b>
Maximum working pressure for SF Pack	bar(e)	10	10	10	10
Maximum working pressure for SF Full-Feature	bar(e)	9.75	9.75	9.75	9.75
Nominal working pressure for SF Pack	bar(e)	10	10	10	10
Nominal working pressure for SF Full-Feature	bar(e)	9.75	9.75	9.75	9.75
Air temperature at outlet valve for SF Pack, approx.	°C	26	28	30	32
Air temperature at outlet valve for SF Full-Feature, approx.	°C	25	25	25	25
Motor shaft speed	r/min	2885	2885	2885	2885
Shaft input	kW	5.9	7.5	11.3	15.0
Sound pressure level	dB(A)	61	62	60	63
<b>For SF Full-Feature also:</b>					
Refrigerant type		R134a	R134a	R134a	R134a
Pressure dewpoint, approx. 2)	°C	3	3	3	3

### 7.14 SF6-15 Multi 100 psi 60 Hz 1)

<b>Compressor type</b>		<b>SF6</b>	<b>SF8</b>	<b>SF11</b>	<b>SF15</b>
		<b>100 psi</b>	<b>100 psi</b>	<b>100 psi</b>	<b>100 psi</b>
Maximum working pressure for SF Pack	bar(e)	8	8	8	8
Maximum working pressure for SF Full-Feature	bar(e)	7.75	7.75	7.75	7.75
Nominal working pressure	bar(e)	7	7	7	7
Air temperature at outlet valve for SF Pack, approx.	°C	26	28	29	30
Air temperature at outlet valve for SF Full-Feature, approx.	°C	23	25	25	25
Motor shaft speed	r/min	3495	3495	3495	3495
Shaft input SF Pack	kW	5.7	7.1	10.7	14.2
Shaft input SF Full-Feature	kW	5.8	7.2	10.8	14.4
Sound pressure level	dB(A)	61	62	60	63
<b>For SF Full-Feature also:</b>					
Refrigerant type		R134a	R134a	R134a	R134a
Pressure dewpoint, approx 2)	°C	3	3	3	3

### 7.15 SF6-15 Multi 125 psi 60 Hz 1)

<b>Compressor type</b>		<b>SF6</b>	<b>SF8</b>	<b>SF11</b>	<b>SF15</b>
		<b>125 psi</b>	<b>125 psi</b>	<b>125 psi</b>	<b>125 psi</b>
Maximum working pressure for SF Pack	bar(e)	9.1	9.1	9.1	9.1
Maximum working pressure for SF Full-Feature	bar(e)	8.85	8.85	8.85	8.85
Nominal working pressure	bar(e)	8.6	8.6	8.6	8.6
Air temperature at outlet valve for SF Pack, approx.	°C	26	28	30	30
Air temperature at outlet valve for SF Full-Feature, approx.		23	25	25	25
Motor shaft speed		3505	3505	3505	3505
Shaft input for SF Pack	kW	5.8	7.4	11.0	14.7
Shaft input for SF Full-Feature	kW	5.9	7.4	11.1	14.8
Sound pressure level	dB(A)	61	62	60	63
<b>For SF Full-Feature also:</b>					
Refrigerant type		R134a	R134a	R134a	R134a
Pressure dewpoint, approx. 2)	°C	3	3	3	3

### 7.16 SF6-15 Multi 145 psi 60 Hz 1)

<b>Compressor type</b>		<b>SF6</b>	<b>SF8</b>	<b>SF11</b>	<b>SF15</b>
		<b>145 psi</b>	<b>145 psi</b>	<b>145 psi</b>	<b>145 psi</b>
Maximum working pressure for SF Pack	bar(e)	10	10	10	10
Maximum working pressure for SF Full-Feature	bar(e)	9.75	9.75	9.75	9.75
Nominal working pressure for SF Pack	bar(e)	10	10	10	10
Nominal working pressure for SF Full-Feature	bar(e)	9.75	9.75	9.75	9.75
Air temperature at outlet valve for SF Pack, approx.	°C	26	28	30	32
Air temperature at outlet valve for SF Full-Feature, approx.		23	25	25	25
Motor shaft speed		3505	3505	3505	3505
Shaft input	kW	5.9	7.5	11.3	15.0
Sound pressure level	dB(A)	61	62	60	63
<b>For SF Full-Feature also:</b>					
Refrigerant type		R134a	R134a	R134a	R134a
Pressure dewpoint, approx. 2)	°C	3	3	3	3

#### Footnotes chapter 7

- 1) At reference conditions
- 2) At 20 °C / 100% relative humidity



## 8 REGULATOR FUNCTIONS FOR SF MULTI

### 8.1 Menu-driven control programs

To facilitate programming and controlling the compressor, menu-driven programs are implemented in the electronic module.

A simplified menu flow is shown in Fig. 8.1.

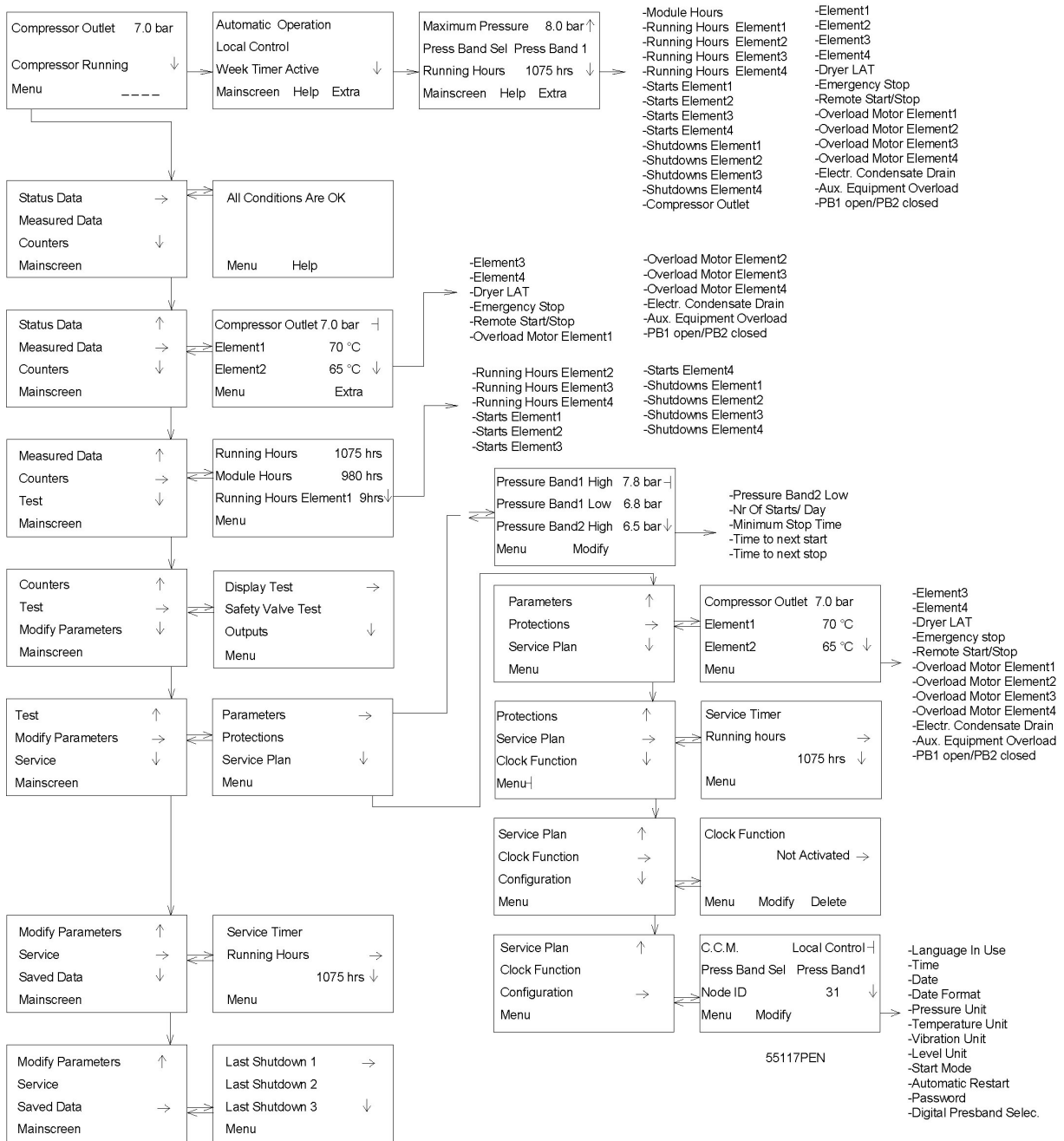

Fig. 8.1 Menu flow SF15 Workplace Full-Feature

### 8.1.1 Function of control programs

Program/Function	Description
Main screen	Shows in short the operation status of the compressor. It is the gateway to all functions. See Fig. 8.2.
Status data	Calling up the status of the compressor protection functions: <ul style="list-style-type: none"> <li>- shut-down</li> <li>- service warning</li> <li>- warning</li> </ul> Resetting of a shut-down and service condition.
Measured data	Calling up: <ul style="list-style-type: none"> <li>- actually measured data</li> <li>- status of some inputs such as the motor overload protection per compressor module</li> </ul>
Counters	Calling up the: <ul style="list-style-type: none"> <li>- running hours</li> <li>- regulator (module) hours</li> <li>- running hours per compressor module</li> <li>- number of starts per compressor module</li> <li>- number of shut-downs per compressor module</li> </ul>
Test	Allows a display test.
Modify parameters	Modifying the settings for: <ul style="list-style-type: none"> <li>- parameters (e.g. number of starts per day)</li> <li>- protections (e.g. dewpoint temperature of dryer for Full-Feature machines)</li> <li>- service plans (see section 8.10)</li> <li>- clock functions (automatic compressor start/stop/pressure band commands)</li> <li>- configuration (time, date, display language, ...)</li> </ul>
Service	Calling up service plans and resetting the timers after carrying out the service actions belonging to a plan. See section 8.13.
Saved data	Calling up the saved data: last shut-down data

### 8.1.2 Main screen

When the voltage is switched on, the Main screen is shown automatically, showing in short the operation status of the compressor.

Compressor Outlet	7.0 bar
Compressor Running Menu	↓
F1	F2
	F3

Fig. 8.2 Main screen, typical example

If the function keys or arrow keys are not used for some minutes, the display will automatically return to the Main screen.

Whenever displayed on a submenu screen, press the key "Mainscreen" to return to the Main screen.

Line	Indicates	Remarks
1	Sensor which is active and the actual reading	The unit for pressure can be bar, psi or kg/cm <sup>2</sup> depending on the programmed selection. The unit for temperature can be °C or °F. See section 8.12.
2	-	-
3	Compressor status	Examples: - Compressor Off - Compressor Running
3	Shut-down	If the unit is shut down, the regulator will automatically show a shut-down message on the display (see section 8.3). It remains possible to have a closer look at other parameters related to the shut-down by means of the menus.
3	Service required	Indicates that the unit needs servicing. Consult section 8.13 to find out the exact cause for this message.
3	Sensor error	Indicates that a sensor is out of order: - Outlet pressure transducer - On Full-Feature compressors, the dewpoint sensor Stop the compressor. Switch off the voltage and depressurize the compressor. Check the sensor wiring. Replace the sensor or transducer, if necessary.
3	Remote control	Indicates that the compressor is set in remote control. Consult Atlas Copco.
4	Functions of keys below display	See section 1.5.7.
4	Symbols:	Indicating the status of each compressor module
	-	indicating that the compressor module is available (ready to run)
	■	indicating that the compressor module is running
	- (blinking)	indicating that the compressor module is not available (due to minimum stop time or too many starts)
	* (blinking)	indicating that the compressor module is shut down

**Note**

When more than one message needs to be displayed (e.g. both warning and service), the messages will be displayed one after the other for 3 seconds.

Press key (F3) on the main screen to check which compressor module is running or stopped.

Element 1	Stopped	
Element 2	Running	
Element 3	Stopped	↓
Menu		
F1	F2	F3

Fig. 8.3 Element status screen, typical example

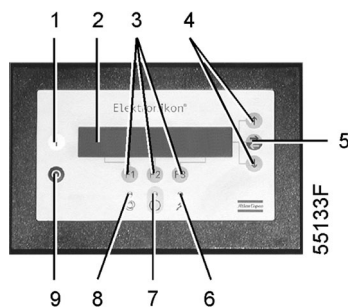

### 8.1.3 Calling up other menus

Starting from the Main screen:

- Use the ↓ key for a quick look at the actual compressor status (see section 8.2)
- Press the key "Menu" (F1), the option "Status data" will be followed by a horizontal arrow:
  - either press the tabulator key (5) to select this menu
  - or use the ↓ key to scroll until the desired submenu is followed by a horizontal arrow and then press the tabulator key (5) to select this menu

## 8.2 Quick look at actual compressor status

### Procedure

1. Starting from the Main screen (see section 8.1.2), press the ↓ key: A screen similar to the one below appears:

Automatic Operation			
Local Control			
Week Timer Active			↓
Mainscreen	Help	Extra	
F1	F2	F3	

Fig. 8.4 Example of an actual compressor status display

**Line 1** indicates the automatic or manual operation status of the regulator:

"Automatic operation" means that the regulator automatically adapts the operation of the compressor, i.e. starting and stopping the compressor modules according to the programmed parameters.

**Line 2** indicates whether the regulator operates in local control, remote control or LAN control mode:

"Local control" means that the start/stop buttons on the keyboard are activated.

"Remote control" means that these functions are controlled remotely. Consult Atlas Copco.

"LAN control" means that the compressor can be controlled by an ES controller.

**Line 3** indicates whether the timer, which generates time-based start and stop commands is activated or not. See section 8.11.

See section 1.5.7 for the functions of the keys "Mainscreen", "Help" and "Extra".

2. Press the ↓ key to get other data (actual compressor conditions of the compressor) as shown in Fig. 8.1.

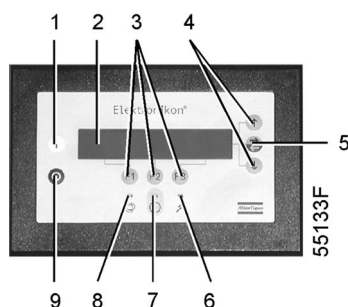

### 8.3 Status data menu

The status data submenu gives information regarding the status of the compressor protection functions (shut-down, service warning and warning) and allows resetting of a shut-down and service condition.

#### Procedure

Starting from the Main screen (see section 8.1.2):

- Press the key "Menu" (F1), the option "Status data" will be followed by a horizontal arrow
- Press the tabulator key (5)

#### 8.3.1 No message exists

In this case, LED (7) is out and the message on the display indicates that all conditions are normal (Fig. 8.5):

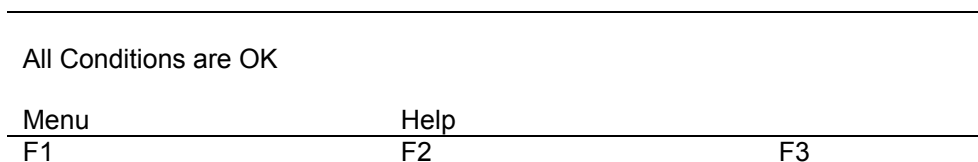

Fig. 8.5 Example of a status data screen

#### 8.3.2 A shut-down message exists

In case the compressor is shut down, LED (7) will blink. A shut-down message exists after an emergency stop or after the temperature switch (TSHH20-Fig.2.8) has tripped (indicated on the display as Aux. Equipment Overload).

In case of a shut-down due to an emergency stop, a screen similar to the one below will appear:

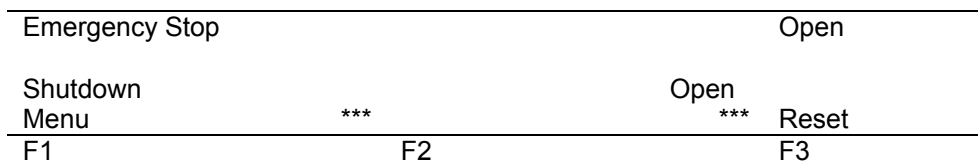
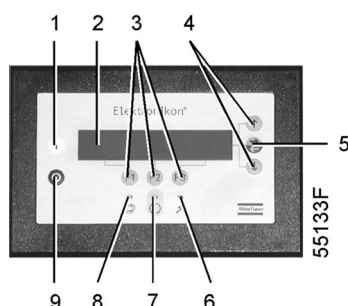

Fig. 8.6 Example of a status data screen

1. The indicators (\*\*\*) are blinking. The screen shows that the compressor is shut down due to an emergency stop. The contacts of the emergency switch are open. The setting of the shut-down is open.



- It remains possible to scroll through other menus, e.g. to check the values of other parameters. When returning to the Status data menu, the option "Shutdowns" will blink. This option can be selected by pressing the tabulator key (5) to return to the shut-down screen (Fig. 8.6).

**Shut-down reset**

- Switch off the voltage, depressurize the compressor and remedy the trouble. After remedying, switch on the voltage and press the key "Reset" (F3).
- Press the keys "Menu" and "Mainscreen" to return to the Main screen and restart the compressor by means of button I.

**8.3.3 A warning message exists**

- If a shut-down warning exists, LED (7) is alight. The Main screen will change into a screen similar to the one below:

Compressor Outlet		7.0 bar
**	Warning	**↓
Menu	***	***
F1	F2	F3

Fig. 8.7 Example of a warning screen

- The indicators (\*\*\*) are blinking and the message \*\*Warning\*\* appears alternately with the messages indicating whether the compressor is in operation or not (Compressor Running or Compressor Off).
- Press the key "Menu" (F1) and the tabulator key (5) to select the Status Data menu, the option "Protection" is blinking.
- Scroll to this option and select it by pressing the tabulator key (5): option "Warnings" blinks. Scroll to this option and select it by pressing the tabulator key (5). A screen similar to the one in Fig. 8.8 appears:

Element 1	80 °C
Warning	Maximum
Menu	***
F1	F2

Fig. 8.8 Example of a warning screen

The screen shows that the temperature at the outlet of element 1 (80 °C) is too high.

- Stop the compressor by means of button **O** and wait until the compressor has stopped.
- Switch off the voltage, inspect the compressor and remedy.
- The warning message will disappear automatically as soon as the warning condition disappears.

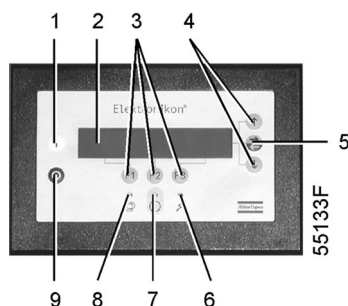

### 8.3.4 A service warning message exists

- LED (7) is alight and the main screen will change into a screen similar to that shown in Fig. 8.9.

Compressor Outlet		7.0 bar
**	Service Required	**↓
Menu	***	---
F1	F2	F3

Fig. 8.9 Example of a service warning screen

- The indicators (\*\*\*) are blinking and the service warning message appears alternately with the messages indicating whether the compressor is in operation or not (Compressor Running or Compressor Off).
- Press the key "Menu" (F1) and the tabulator key (5) to select the Status data menu: the option "Service" is blinking.
- Scroll to this option and select it by pressing the tabulator key (5), two options may blink: "Inputs": option is not applicable. "Plan": if a service plan interval is exceeded. See section 8.15.2.
- Stop the compressor and switch off the voltage.
- The service message was referring to "Plan": carry out the service actions related to the indicated plans. Reset the timers of the related plans as described in section 8.13.

### 8.4 Measured data menu

#### Function

To call up information regarding the actually measured data and the status of some inputs such as the motor overload protection per compressor module.

#### Procedure

- Starting from the Main screen (see section 8.1.2):
  - press the key "Menu" (F1)
  - press the ↓ key until the option "Measured data" is followed by a horizontal arrow
  - press the tabulator key (5) to activate the menu

Compressor Outlet		7.0 bar	↔
Element 1		75 °C	
Element 2		70 °C	↓
Menu		Extra	
F1	F2	F3	

Fig. 8.10 Example of a measured data screen

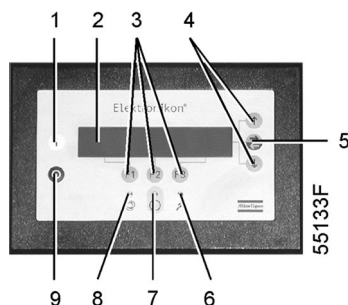

2. By pressing the ↓ key, a number of actually measured data can be found (see Fig. 8.1).
3. If one of the sensors is linked to a shut-down, service or warning function, both the actually measured value as well as the corresponding shut-down, warning or service level can be called up by pressing the tabulator key (5).

## 8.5 Counters menu

### Function

To allow the operator to call up the:

- running hours
- regulator (module) hours (the hours the module has been under tension)
- running hours per compressor module
- starts per compressor module
- shutdowns per compressor module

### Procedure

1. Starting from the Main screen (see section 8.1.2):
  - press the key "Menu" (F1)
  - press the ↓ key until the option "Counters" is followed by a horizontal arrow
  - press the tabulator key (5) to activate the menu
2. By pressing the ↓ key, the above-mentioned data can be found (see also Fig. 8.1).

## 8.6 Test menu

### Function

To carry out a display test, i.e. to check whether the display and LEDs are still intact.

### Procedure

1. Starting from the Main screen (see section 8.1.2):
  - press the key "Menu" (F1)
  - press the ↓ key until the option "Test" is followed by a horizontal arrow
  - press the tabulator key (5) to activate the menu
2. The option "Display test" will be followed by a horizontal arrow.
3. After pressing the tabulator key (5), the regulator will generate a series of patterns on the display which enable the operator to check that each pixel still functions normally; at the same time the LEDs are lit.

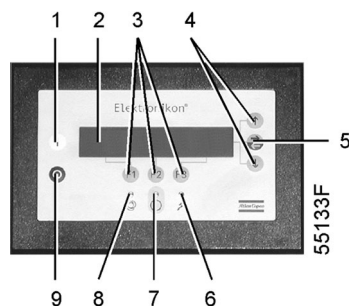



## 8.7 Modify parameters menu

### Function

The menu allows the operator to program:

- Parameters, see section 8.8.
- Protections settings, see section 8.9.
- Service plan settings, see section 8.10.
- Clock function settings, see section 8.11.
- Configuration settings, see section 8.12.

## 8.8 Modifying parameters

### Function

To modify a number of parameters as mentioned below and in Fig. 8.1.

- Pressure Band 1 High
- Pressure Band 1 Low
- Pressure Band 2 High
- Pressure Band 2 Low
- Number Of Starts/Day (per compressor module)
- Minimum Stop Time (i.e. the time period during which the compressor, if stopped automatically, remains stopped whatever happens with the air net pressure)
- Power recovery time (if automatic restart after voltage failure is activated) **3)**
- Restart delay (can be programmed, allowing e.g. compressors to be restarted one after the other)
- Time to next start (time between the starting of two compressor modules)
- Time to next stop (time between the stopping of two compressor modules during regulation)

### Procedure

1. Starting from the Main screen (see section 8.1.2):
  - press the key "Menu" (F1)
  - press the ↓ key until the option "Modify Parameters" is followed by a horizontal arrow
  - press the tabulator key (5) to activate the menu
2. The first option ("Parameters") will be followed by a horizontal arrow.
3. Press the tabulator key (5): the first item ("Pressure Band 1 High") and its setting will appear.
4. Use the ↓ key to scroll until the parameter to be modified is followed by a horizontal arrow.

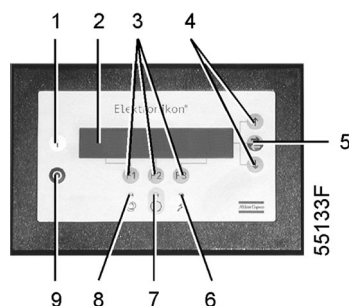

### 8.8.1 Modifying the pressure bands

If desired, the operator can program two pressure bands (band 1 and band 2) with different pressure settings. The settings for band 1 are indicated as "Pressure Band 1 High" and "Pressure Band 1 Low", the settings for band 2 are indicated as " Pressure Band 2 High " and " Pressure Band 2 Low ".

Example:

For pressure band 1:

- Pressure Band 1 Low: 6.8 bar
- Pressure Band 1 High: 7.8 bar

For pressure band 2:

- Pressure Band 2 Low: 5.5 bar
- Pressure Band 2 High: 6.5 bar

#### Procedure

1. Consult the section above to select the parameter Pressure Band 1 High:

Pressure Band 1 High	7.8 bar	↑
Pressure Band 1 Low	6.8 bar	
Pressure Band 2 High	6.5 bar	↓
Menu	Modify	
F1	F2	F3

Fig. 8.11 Modify parameters menu

2. The screen shows that the current setting of Pressure Band 1 High is 7.8 bar(e). To modify this setting, press the key "Modify" (F2):

Pressure Band 1 High	7.8 bar
Program	Limits
F1	F2
	Cancel
	F3

Fig. 8.12 Modify parameters menu

3. The key "Limits" (F2) can be used to find the limitations for the parameter. Use the ↓ or ↑ arrow key to change the value.
4. Press the key "Program" (F1) to program the new setting or the key "Cancel" (F3) to cancel the modification operation.
5. The procedure to modify the Pressure Band 1 Low is similar to the description above.
6. If required, repeat the procedure for the Pressure Band 2 High and Pressure Band 2 Low (pressure band 2).

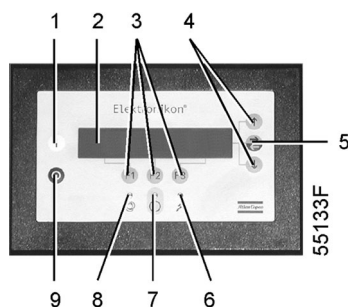

## 8.9 Modifying protection settings

### Function

1. To modify protection settings: warning ("Warning"), e.g. Dryer LAT (Low Ambient Temperature) on Full-Feature machines
2. To check some compressor conditions, e.g. the status of the motor overload contacts per compressor module. The list of parameters is shown in Fig. 8.1.

### Note

Some parameters cannot be modified.

### Procedure

1. Starting from the Main screen (see section 8.1.2):
  - press the key "Menu" (F1)
  - press the ↓ key until the option "Modify parameters" is followed by a horizontal arrow
  - press the tabulator key (5) to activate the menu
2. Use the ↓ key to scroll until the option "Protections" is followed by a horizontal arrow.
3. Press the tabulator key (5): the first item ("Compressor outlet") and its value will appear.
4. Use the ↓ key to scroll until the parameter to be modified or checked is followed by a horizontal arrow.
5. press the tabulator key (5) to select the parameter

### 8.9.1 Checking protections for compressor modules

1. Consult the section above to select the parameter Element 1:

Element 1		70 °C
Warning	Maximum	75 °C
Back		
F1	F2	F3

Fig. 8.13 Modify parameters menu

2. The screen shows that the current temperature is 70 °C and that the shut-down setting is 75 °C.

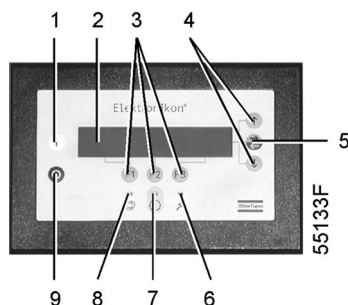

### 8.9.2 Modifying protections for Dryer LAT on Full-Feature machines

1. Consult the section above to select the parameter Dryer LAT (Low Ambient Temperature):

Dryer LAT		10 °C	
Warning	Maximum	25 °C	→
Back	Modify		↓
F1	F2	F3	

Fig. 8.14 Modify parameters menu

2. The screen shows that the Dryer LAT is 10 °C and that the shut-down setting is 25 °C. To modify this setting, press the key "Modify" (F2):

Dryer LAT		10 °C	
Warning	Maximum	25 °C	
Program	Limits	Cancel	
F1	F2	F3	

Fig. 8.15 Modify parameters menu

3. The key "Limits" (F2) can be used to find the limitations for the parameter. Use the ↓ or ↑ arrow key to change the value.
4. Press the key "Program" (F1) to program the new setting or the key "Cancel" (F3) to cancel the modification operation.

**Note:**

The modifying procedure for other settings is similar. For some settings, a delay can be programmed. See section 8.15.

### 8.10 Modifying service plans

**Function**

To modify the hour intervals for the Service plans.

**Service plans**

The service operations to be carried out are grouped in plans, called Service plan A, B, D or I. When reaching an interval, a message will appear on the screen indicating which Service plans are to be carried out.

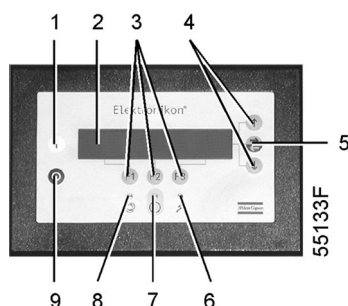

**Important**

Always consult Atlas Copco in case any timer setting should be changed. The intervals must not exceed the periods below and must coincide logically.

**Programmed service plan intervals**

<b>Service plans</b>	<b>Intervals</b>
Service plan I	Each 2500 running hours
Service plan A	Each 5000 running hours
Service plan B	Each 10000 running hours
Service plan D	Each 20000 running hours

**Resulting service actions to be carried out**

<b>Service actions according to</b>	<b>At</b>
Service plan I	2500 running hours
Service plan I and A	5000 running hours
Service plan I, A and B	10000 running hours
Service plan I, A, B and D	20000 running hours
...	...

**Procedure**

1. Starting from the Main screen (see section 8.1.2):
  - press the key "Menu" (F1)
  - press the ↓ key until the option "Modify parameters" is followed by a horizontal arrow
  - press the tabulator key (5) to activate the menu
2. Use the ↓ key to scroll until the option "Service plan" is followed by a horizontal arrow.
3. Press the tabulator key (5): a screen similar to the one below will appear:

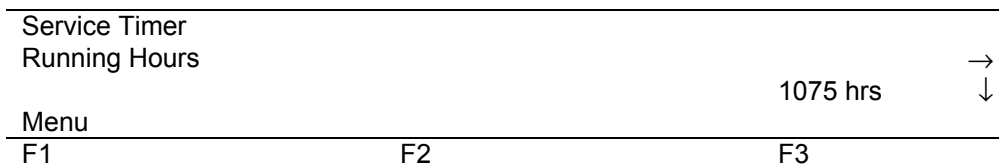
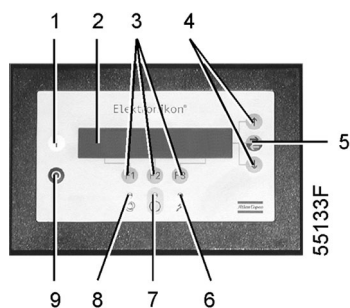

Fig. 8.16 Service menu

The screen shows the actual running hours (1075).



4. Press the tabulator key (5): a screen similar to the one below will appear:

Service Timer		
Level	A	↓
	5000 hrs	
Menu	Modify	
F1	F2	F3

Fig. 8.17 Service plan menu

5. The screen indicates that the level for Service plan A is set at 5000 running hours.
6. Press the "Modify" key. The key "Limits" (F2) can be used to find the limitations for the parameter. Use the ↓ or ↑ arrow key to modify the interval.
7. Press the key "Program" (F1) to program the new setting or the key "Cancel" (F3) to cancel the modification operation.
8. The procedure to modify the Service plans B, D and I are carried out in a similar way. Press the ↓ key in Fig. 8.17 to find the other Service plans.

### 8.11 Programming Clock function

To program:

- time-based start/stop commands for the compressor
- time-based change-over commands for the net pressure band (see also section 8.8.1)

#### 8.11.1 Programming start/stop/pressure band commands

In this example, the compressor will be programmed as follows:

- On Monday at 06:15 starting in pressure band 1
- On Friday at 18:00 changing over to pressure band 2
- On Saturday at 18:00 stopping

1. Starting from the Main screen (see section 8.1.2):
  - press the key "Menu" (F1)
  - press the ↓ key until the option "Modify parameters" is followed by a horizontal arrow
  - press the tabulator key (5) to activate the menu
2. Use the ↓ key to scroll until the option "Clock function" is followed by a horizontal arrow. Press the tabulator key (5), following screen appears:

Clock Function		
		Not activated →
Menu	Modify	Delete
F1	F2	F3

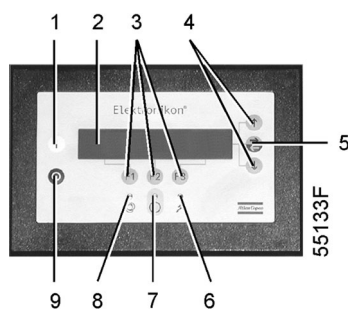

- Press the tabulator key (5), following screen appears:

Monday		→
Tuesday		
Wednesday		↓
Back		Delete
F1	F2	F3

- Use the ↓ or ↑ key until the day on which a command must be programmed is followed by a right pointing arrow. Press the tabulator key (5), following screen appears:

--:--	-----	↓
--:--	-----	
--:--	-----	↓
Back	Modify	Delete
F1	F2	F3

- Press the key "Modify" (F2). The first two digits will flash. Use the ↓ or ↑ key to enter "06". Press the tabulator key to jump to the following two dashes. Use the ↓ or ↑ key to enter "15". Press the tabulator key to jump to the row of dashes. Use the ↓ or ↑ key to enter the command Start. Press the key "Program" to program the command: 06:15 Start
- Press the ↓ key: the symbol ↓ indicates that the second line is accessible. Press the key "Modify" and modify this line to the following command line: 06:15 Pressure Band 1 in a similar way.
- Press the key "Back" (F1) and scroll to "Friday":

Thursday		↑
Friday		→
Saturday		↓
Back		Delete
F1	F2	F3

- Programming the command to change over at 18 o'clock to Pressure Band 2 is carried out in a similar way as described above.
- Press the key "Back" (F1) and scroll to "Saturday". Programming the command to stop at 18 o'clock is carried out in a similar way as described above.

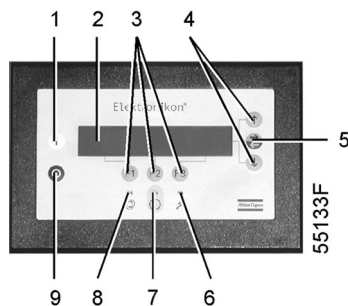

### 8.11.2 To activate/deactivate the timer

1. Starting from the Main screen (see section 8.1.2):
  - press the key "Menu" (F1)
  - press the ↓ key until the option "Modify parameters" is followed by a horizontal arrow
  - press the tabulator key (5) to activate the menu
2. Use the ↓ key to scroll until the option "Clock function" is followed by a horizontal arrow. Press the tabulator key (5), following screen appears:

Clock Function		
		Not activated →
Menu	Modify	Delete
F1	F2	F3

3. Press the key "Modify", "Not activated" starts blinking.
4. Press the ↓ key, "Not activated" changes into "Activated".
5. Press the key "Program".

**Important:**

1. It is necessary to program the start/stop/pressure band commands in successive order timewise, e.g.:
  - 07.30 start
  - 07.30 pressure band 1
  - 08.30 pressure band 2
  - 17.00 stop
  - etc.
2. Make sure that the clock function is activated (indicated as "Activated"). If not, the programmed start/stop commands will not be executed.

### 8.11.3 To modify a command

Suppose the command to stop the compressor on Saturday 18:00 is to be modified: stopping at 17 o'clock instead of 18 o'clock:

1. Starting from the Main screen (see section 8.1.2):
  - press the key "Menu" (F1)
  - press the ↓ key until the option "Modify parameters" is followed by a horizontal arrow
  - press the tabulator key (5) to activate the menu

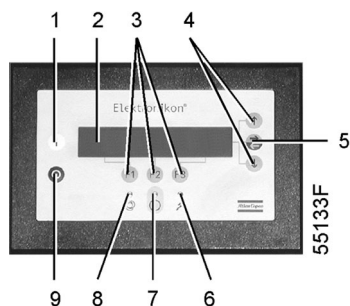



- Use the ↓ key to scroll until the option "Clock function" is followed by a horizontal arrow. Press the tabulator key (5), following screen appears:

Clock Function			Not activated →
Menu	Modify	Delete	
F1	F2	F3	

- Press the tabulator key (5), following screen appears:

Monday		→
Tuesday		
Wednesday		↓
Menu		Delete
F1	F2	F3

- Scroll through the display until "Saturday" is followed by a horizontal arrow. Press the tabulator key (5). If necessary, scroll through the compressor start/stop/pressure band commands until the command to be modified is followed by symbol | on the screen. Press the key "Modify", the first two digits of the command start blinking. Modify as required using the scroll keys, i.e. in the example above change "18" into "17" using the ↓ key.
- If necessary, press the tabulator key (5) to go to the next field to be modified, the minutes indication and the start/stop/pressure band indication.
- Press the key "Program" to program the new command or the key "Cancel" to quit without reprogramming.

#### 8.11.4 To add a command

##### Adding a command at the end of an existing list

- Starting from the Main screen (see section 8.1.2):
  - press the key "Menu" (F1)
  - press the ↓ key until the option "Modify parameters" is followed by a horizontal arrow
  - press the tabulator key (5) to activate the menu
- Use the ↓ key to scroll until the option "Clock function" is followed by a horizontal arrow. Press the tabulator key (5), following screen appears:

Clock Function			Not activated →
Menu	Modify	Delete	
F1	F2	F3	

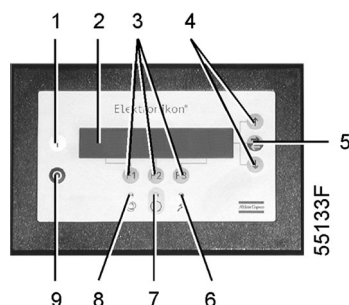

Suppose the command to stop the compressor at 18:00 must be added to the list of Monday:  
 - 06:15 start  
 - 06:15 pressure band 1

3. Press the tabulator key (5), following screen appears:

Monday		→
Tuesday		
Wednesday		↓
Menu		Delete
F1	F2	F3

4. Scroll through the display until "Monday" is followed by a horizontal arrow. Press the tabulator key (5). Scroll through the compressor start/stop/pressure band commands until the first empty command line is indicated by symbol | on the screen.
5. Press the key "Modify", the first two digits of the command start blinking. Enter "18:00 stop" using the scroll keys ↓ or ↑ to modify a field and the tabulator key (5) to jump from one field to another.
6. Press the key "Program" to program the new command or the key "Cancel" to quit without reprogramming.

### Adding a command between two existing commands

1. Suppose the command 17:00 pressure band 2 must be added to following list:  
 - 06:00 start  
 - 06:00 pressure band 1  
 - 18:00 stop
2. The regulator does not allow to enter a new command which is situated timewise before the last command in the list.
3. Scroll through the display until the command before which the new command must be entered is followed by symbol | (in the example above: 18:00 stop) and press the key "Modify". Change this command to the new command (in the example above: 17:00 pressure band 2) and press the "Program". Press the ↓ key, add the last command of the list (in the example above: 18:00 stop) and press the key "Program".

### 8.11.5 To delete commands

1. Starting from the Main screen (see section 8.1.2):  
 - press the key "Menu" (F1)  
 - press the ↓ key until the option "Modify parameters" is followed by a horizontal arrow  
 - press the tabulator key (5) to activate the menu

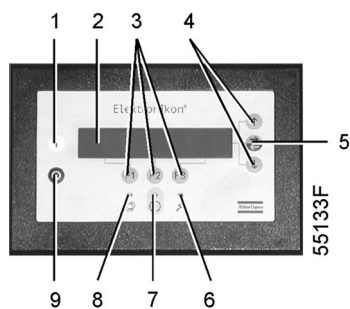

- Use the ↓ key to scroll until the option "Clock function" is followed by a horizontal arrow. Press the tabulator key (5), following screen appears:

Clock Function			Not activated	→
Menu	Modify	Delete		
F1	F2	F3		

### Deleting all commands

Press the key "Delete" (F3) in the screen above. A question to confirm the deleting operation will appear.

### Deleting all commands related to a specific day

Scroll through the display until the desired day is followed by a horizontal arrow. Press the key "Delete" (F3). A question to confirm the deleting operation will appear.

### Deleting a specific start/stop/pressure band command

Scroll through the display until the desired start, stop, pressure band 1 or pressure band 2 command line is followed by symbol ↵. Press the key "Delete" (F3). A question to confirm the deleting operation will appear.

## 8.12 Configuration menu

### Function

To reprogram a number of parameters. See Fig. 8.1.

### Procedure

- Starting from the Main screen (see section 8.1.2):
  - press the key "Menu" (F1)
  - press the ↓ key until the option "Modify parameters" is followed by a horizontal arrow
  - press the tabulator key (5) to activate the menu
- Use the ↓ key to scroll until the option "Configuration" is followed by a horizontal arrow.
- Press the tabulator key (5): The first option shown is "C.C.M" (Compressor Control Mode). If another option is desired, scroll through the display (using ↓ or ↑ keys) until the option is followed by symbol ↵.
- In case of option "Time", the first line indicates the actual setting, e.g. 14:30 followed by symbol ↵.

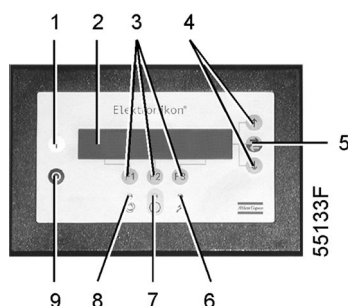

5. If it is desired to modify the time, press the key "Modify". If not, press the key "Menu" to return to the submenu.
6. After pressing the key "Modify", the first field (14) will blink. Modify the hours using the ↓ or ↑ keys. Then press the tabulator key (5) to go to the next field (i.e. 30). The setting of this field can now be modified with the ↓ or ↑ keys.
7. The bottom line of the display will show two options:
  - "Program" to program the new setting
  - "Cancel" to cancel the new setting
8. Proceed in a similar way for the other parameters to be modified.

### 8.12.1 Programming compressor control modes

#### Compressor control modes

The compressor can be controlled locally, remotely or via a local area network (LAN – consult Atlas Copco).

#### Procedure

1. Starting from the Main screen (see section 8.1.2):
  - press the key "Menu" (F1)
  - press the ↓ key until the option "Modify parameters" is followed by a horizontal arrow
  - press the tabulator key (5) to activate the menu
2. Use the ↓ key to scroll until the option "Configuration" is followed by a horizontal arrow.
3. Press the tabulator key (5): The first option shown is "C.C.M." (Compressor Control Mode), followed by the actual setting. Following screen is shown:

C.C.M.	Local Control	↑
Pressure Band Selected	Pressure Band 1	
Node ID	31	↓
Menu	Modify	
F1	F2	F3

Fig. 8.18 Compressor control mode menu

4. Press the key "Modify" and use ↓ or ↑ keys to select the desired control mode. Press the "Program" key to program or the "Cancel" key to cancel the modification.

### 8.13 Service menu

#### Function

- To reset the service plans which are carried out.
- To check for both the next service plans to be carried out and to find which service plans were carried out previously.

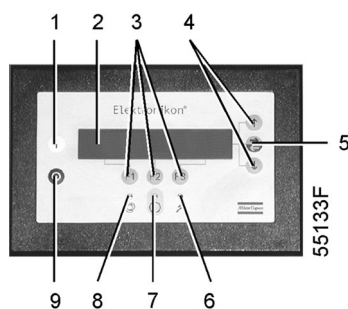

### Service plans

- Contact your Atlas Copco customer centre for the service actions related to these plans.
- Consult section 8.10 if any modification to the intervals should be required.

When the service plan interval is reached, a message will appear on the screen. See section 8.3.

### Example

#### Programmed service plan intervals

Service plans	Intervals
Service plan I	Each 2500 running hours
Service plan A	Each 5000 running hours
Service plan B	Each 10000 running hours
Service plan D	Each 20000 running hours

#### Resulting service actions to be carried out

Service actions according to	At
Service plan I	2500 running hours
Service plan I and A	5000 running hours
Service plan I, A and B	10000 running hours
Service plan I, A, B and D	20000 running hours
...	...

### Procedure

- Starting from the Main screen (see section 8.1.2):
  - press the key "Menu" (F1)
  - press the ↓ key until the option "Service" is followed by a horizontal arrow
  - press the tabulator key (5) to activate the menu
- A screen similar to the one below appears:

Service Timer			
Running Hours		7971 hrs	→ ↓
Menu			
F1	F2	F3	

Fig. 8.19 Service menu, typical example

The screen shows that the total compressor running time is 7971 hrs.

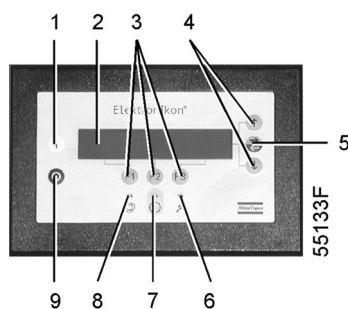

3. Press the tabulator key (5):

Next Timer		
Level		ABI 10000 hrs    ↓
Back		
F1	F2	F3

Fig. 8.20 Service menu, typical example

The screen shows that the next service plans to be carried out are plans A, B and I and that these plans are to be carried out each 10000 running hours.

4. Press the ↓ key to find which service plans were carried out previously:

Previous Timer			↑
Level		AI 5008 hrs	
Back			
F1	F2	F3	

Fig. 8.21 Service menu, typical example

The screen shows that service plans A and I were carried out at 5008 running hours.

5. Stop the compressor, switch off the voltage and carry out the service operations related to plans A, B and I.
6. Switch on the voltage and scroll to the service screen shown in Fig. 8.20. Press the "Reset" button (F3) to reset the timer. Confirm the question for resetting.

**Notes**

- The "Reset" button only appears when the next Timer level is almost reached (from 400 running hours before elapsing of the service plan interval).
- After pressing the ↓ key in Fig. 8.19, the Life time hours are shown (i.e. the number of hours elapsed since initial programming ex-factory). This counter is not taken into account.

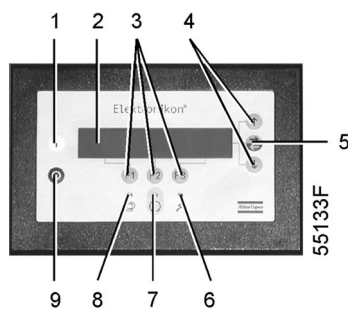

## 8.14 Saved data menu

### Function

To call up some compressor data saved by the regulator. These data are:

- Last shut-down data
- Last emergency stop data

### Procedure

1. Starting from the Main screen (see section 8.1.2):
  - press the key "Menu" (F1)
  - press the ↓ key until the option "Saved data" is followed by a horizontal arrow
  - press the tabulator key (5) to activate the menu
2. The list of last shut-down cases is shown.
3. Scroll through the items to select the desired shut-down item.
4. Press the tabulator key (5) to find the date, time and other data reflecting the status of the compressor at the last shut-down occurred.

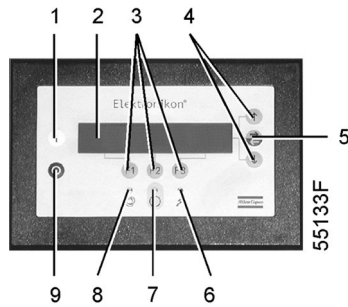

## 8.15 Programmable settings

### 8.15.1 Regulation settings

		Minimum setting	Nominal setting	Maximum setting
Number of motor starts	starts/day	240	720	720
Minimum stop time 1)	sec	5	5	30
Stop between 2 compressor modules	sec	2	2	5
Start between 2 compressor modules	sec	2	2	10
Power recovery time 3)	sec	10	10	3600
Delay at restarting after power recovery 3)	sec	0	0	1200
<b>Minimum pressure 2)</b>				
8 bar Pack	bar(e)	4	7	7.9
8 bar Full-Feature	bar(e)	4	6.8	7.7
10 bar Pack	bar(e)	4	9	9.9
10 bar Full-Feature	bar(e)	4	8.8	9.7
100 psi Pack	bar(e)	4	7	7.9
100 psi Full-Feature	bar(e)	4	6.8	7.7
125 psi Pack	bar(e)	4	8.1	9
125 psi Full-Feature	bar(e)	4	7.75	8.8
145 psi Pack	bar(e)	4	9	9.9
145 psi Full-Feature	bar(e)	4	8.8	9.7
<b>Maximum pressure 2)</b>				
8 bar Pack	bar(e)	4.1	8	8
8 bar Full-Feature	bar(e)	4.1	7.8	7.8
10 bar Pack	bar(e)	4.1	10	10
10 bar Full-Feature	bar(e)	4.1	9.8	9.8
100 psi Pack	bar(e)	4.1	8	8
100 psi Full-Feature	bar(e)	4.1	7.8	7.8
125 psi Pack	bar(e)	4.1	9.1	9.1
125 psi Full-Feature	bar(e)	4.1	8.9	8.9
145 psi Pack	bar(e)	4.1	10	10
145 psi Full-Feature	bar(e)	4.1	9.8	9.8
<b>For Full-Feature also 4)</b>				
Dewpoint warning temperature	°C	3	15	40
Delay at signal 5)	sec	0	3	10
Delay at starting 6)	sec	0	255	255



### 8.15.2 Service settings

		Minimum setting	Nominal setting	Maximum setting
Service Plan I	hr	2000	2500	2500
Service Plan A	hr	4000	5000	5000
Service Plan B	hr	8000	10000	10000
Service Plan D	hr	16000	20000	20000

#### Footnotes chapter 8

- 1) Once the compressor module is automatically stopped, it will remain stopped for **the minimum stop time**, whatever happens with the air net pressure.
- 2) The regulator does not accept illogical settings, e.g. if the stopping pressure is programmed at 7.0 bar(e), the maximum limit for the starting pressure changes into 6.9 bar(e). The recommended minimum pressure difference between starting and stopping is 0.6 bar.
- 3) Is only accessible if the automatic restart function is activated. **The power recovery time** (the period within which the voltage must be restored to have an automatic restart) can be set between 10 and 3600 seconds. A **delay at restarting** can also be programmed, allowing e.g. compressors to be restarted one after the other. To activate the automatic restart function, consult Atlas Copco.
- 4) Full-Feature version is the Pack version with integrated air dryer.
- 5) Is the time period during which the warning signal must exist before the warning message appears.
- 6) Is the time period during which the warning signal is ignored after starting to allow the dryer to reach the dewpoint temperature.

## 9 CONVERSION LIST OF SI UNITS INTO US/BRITISH UNITS

1 bar = 14.504 psi  
 1 g = 0.0353 oz  
 1 kg = 2.205 lb  
 1 km/h = 0.621 mile/h  
 1 kW = 1.341 hp (UK and US)  
 1 l = 0.264 US gal  
 1 l = 0.220 Imp (UK gal)  
 1 l = 0.0353 cu.ft  
 1 m = 3.281 ft  
 1 mm = 0.0394 in  
 1 m<sup>3</sup>/min = 35.315 cfm  
 1 mbar = 0.401 in water column  
 1 N = 0.225 lbf  
 1 Nm = 0.738 lbf.ft  
 X °C = (1.8X + 32) °F 1)

#### Footnotes chapter 9

- 1) A temperature difference of 1 °C = a temperature difference of 1.8 °F



Product: SF1-4 Skid and Tank-Mounted  
SF6-8 Twin  
SF6-15 Multi

## Instructions for use of air receiver

- 1 This vessel can contain pressurized air; be ware of its potential danger in case of misuse.
- 2 The vessel shall only be used to store compressed air and shall not be subject to rapid fluctuation of pressure.
- 3 This vessel shall only be used within the pressure and temperature limits stated on the data plate and the testing report, which should be kept with care.
- 4 No alterations shall be made to this vessel by welding, drilling or any other mechanical methods without written permission of the manufacturer.
- 5 Make sure that the vessel is complete with suitable and appropriate safety and control fittings and replace them with new Atlas Copco ones (consult the parts list) if necessary.  
The safety valve must be fitted directly to the vessel and the discharge capacity should be higher than the air intake of the compressor. It should be set and leaded at a pressure of 11 bar.
- 6 Do not store the vessel near heating sources and inflammable substances and avoid storage of the vessel in badly ventilated rooms.
- 7 Use vibration dampers to reduce the vibration during operation, which can cause failure.  
Do not mount the vessel to the ground or fixed structures.
- 8 Drain condensate from the vessel daily, to prevent corrosion inside the vessel. During maintenance, every 12 months, check for the presence of internal corrosion. Check more frequently if the vessel is used with an oil-free compressor or when it is used in adverse conditions (high humidity, presence of acids).  
If corrosion is present, the minimum thickness is 3.45 mm for the shell and 3.4 mm for the head.  
The legal checks have to be made in accordance with the local laws and rules where the vessel is used.

## PED (Pressure Equipment Directive)

### Components subject to 97/23/EC Pressure Equipment Directive

Components subject to 97/23/EC Pressure Equipment Directive greater than or equal to Category II.

Part number	Description	PED Class
0830 1007 75	Safety valve	IV
0830 1007 76	Safety valve	IV
0830 1007 68	Safety valve	IV

### Overall Rating

The compressors are conform to PED smaller than or equal to category I.

**Notes:**

**Notes:**

# OWNERSHIP DATA

Compressor type: .....	Unit serial No. compressor: .....
Air dryer type: .....	Unit serial No. dryer: .....
Motor type: .....	Motor serial No.: .....
Delivery date: .....	First start-up date: .....
Service Plan: .....	Owner's machine No.: .....
Selected lubricants	
Compressor: .....	Capacity: .....
Bearing grease type, electric motor: .....	Capacity .....
Dryer gearbox .....	
Printed Matter Nos.	
Atlas Copco compressor instruction book: .....	Atlas Copco air dryer instruction book: .....
Atlas Copco compressor parts list: .....	Atlas Copco air dryer parts list: .....
Atlas Copco logbook: .....	
Local Atlas Copco Representative	
Name: .....	
Address: .....	
Telephone: .....	Contact persons: Service: .....
Telex: .....	Parts: .....
E-mail .....	

## SAFETY PRECAUTIONS

To be read attentively and acted accordingly before installing, operating or repairing the unit.

These recommendations apply to machinery processing or consuming air or inert gas. Processing of any other gas requires additional safety precautions typical to the application which are not included herein.

In addition to normal safety rules which should be observed with stationary air compressors and equipment, the following safety directions and precautions are of special importance.

When operating this unit, the operator must employ safe working practices and observe all related local work safety requirements and ordinances.

The owner is responsible for maintaining the unit in a safe operating condition. Parts and accessories shall be replaced if unsuitable for safe operation.

Installation, operation, maintenance and repair shall only be performed by authorized, trained, competent personnel.

Normal ratings (pressures, temperatures, time settings, etc.) shall be durably marked.

Any modification on the compressor or air dryer shall only be performed in agreement with Atlas Copco and under supervision of authorized, competent personnel.

If any statement in this book, especially with regard to safety, does not comply with local legislation, the stricter of the two shall apply.

These precautions are general and cover several machine types and equipment; hence some statements may not apply to the unit(s) described in this book.

### Installation

Apart from general engineering practice in conformity with the local safety regulations, the following directives are specially stressed:

1. A compressor or air dryer shall be lifted only with adequate equipment in conformity with local safety rules.  
  
Loose or pivoting parts shall be securely fastened before lifting. It is strictly forbidden to dwell or stay in the risk zone under a lifted load. Lifting acceleration and retardation shall be kept within safe limits.  
  
Wear a safety helmet when working in the area of overhead or lifting equipment.
2. Any blanking flanges, plugs, caps and desiccant bags shall be removed before connecting up the pipes. Distribution pipes and connections shall be of correct size and suitable for the working pressure.
3. Place the unit where the ambient air is as cool and clean as possible.

If necessary, install a suction duct. Never obstruct the air inlet. Care shall be taken to minimize the entry of moisture with the inlet air.

4. The aspirated air shall be free from flammable fumes or vapours, e.g. paint solvents, that can lead to internal fire or explosion.
5. Air-cooled units shall be installed in such a way that an adequate flow of cooling air is available and that the exhausted air does not recirculate to the inlet.
6. Arrange the air intake so that loose clothing of people cannot be sucked in.
7. Ensure that the discharge pipe from the compressor to the aftercooler, air dryer or air net is free to expand under heat and that it is not in contact with or close to flammable material.
8. No external force may be exerted on the air outlet valve; the connected pipe must be free of strain.
9. If remote control is installed, the unit shall bear an obvious sign reading:

DANGER: This machine is remotely controlled and may start without warning.

As a further safeguard, persons switching on remotely controlled units shall take adequate precautions to ensure that there is no one checking or working on the machine. To this end, a suitable notice shall be affixed to the start equipment.

10. On units with automatic start-stop system, a sign stating "This machine may start without warning" shall be attached near the instrument panel.
11. In multiple compressor systems manual valves shall be installed to isolate each compressor. Non-return valves (check valves) shall not be relied upon for isolating pressure systems.
12. Never remove or tamper with the safety devices, guards or insulations fitted on the unit. Every pressure vessel or auxiliary installed outside the unit to contain air above atmospheric pressure shall be protected by a pressure-relieving device or devices as required.
13. Pipework or other parts with a temperature in excess of 80 degrees celsius and which may be accidentally touched by personnel in normal operation shall be guarded or insulated. Other high-temperature pipework shall be clearly marked.

## SAFETY PRECAUTIONS (continued)

14. If the ground is not level or can be subject to variable inclination, consult Atlas Copco.
15. The electrical connections shall correspond to the local codes. The units shall be grounded and protected against short circuits by fuses.
- 5 Never use flammable solvents or carbon tetrachloride for cleaning parts. Take safety precautions against toxic vapours of cleaning liquids.
- 6 Scrupulously observe cleanliness during maintenance and repair. Keep dirt away by covering the parts and exposed openings with a clean cloth, paper or tape.

### Operation

- 1 Air hoses shall be of correct size and suitable for the working pressure. Never use frayed, damaged or deteriorated hoses. Use only the correct type and size of hose end fittings and connections. When blowing through a hose or air line, ensure that the open end is held securely. A free end will whip and may cause injury. Make sure that a hose is fully depressurized before disconnecting it.  
  
Never play with compressed air. Do not apply it to your skin or direct an air stream at people. Never use it to clean dirt from your clothes. When using it to clean equipment, do so with extreme caution and use eye protection.
- 2 The compressor is not considered as capable of producing air of breathing quality. For breathing air quality, the compressed air must be adequately purified according to local legislation and standards.
- 3 Never operate the units when there is a possibility of taking in flammable or toxic fumes.
- 4 Never operate the units at pressures below or in excess of their limit ratings as indicated on the Principal Data sheet.
- 5 Keep all bodywork doors shut during operation. The doors may be opened for short periods only, e.g. to carry out checks. Wear ear protectors when opening a door.
- 6 People staying in environments or rooms where the sound pressure level reaches or exceeds 90 dB(A) shall wear ear protectors.
- 7 Periodically check that:
  - a All guards are in place and securely fastened
  - b All hoses and/or pipes inside the unit are in good condition, secure and not rubbing
  - c There are no leaks
  - d All fasteners are tight
  - e All electrical leads are secure and in good order
  - f Safety valves and other pressure-relief devices are not obstructed by dirt or paint
  - g Air outlet valve and air net, i.e. pipes, couplings, manifolds, valves, hoses, etc. are in good repair, free of wear or abuse
- 8 If warm cooling air from compressors is used in air heating systems, e.g. to warm up a workroom, take precautions against air pollution and possible contamination of the breathing air.
- 9 Do not remove any of, or tamper with, the sound-damping material.
- 7 Never weld or perform any operation involving heat near the oil system. Oil tanks must be completely purged, e.g. by steam-cleaning, before carrying out such operations.  
  
Never weld on, or in any way modify, pressure vessels.  
  
Whenever there is an indication or any suspicion that an internal part of a machine is overheated, the machine shall be stopped but no inspection covers shall be opened before sufficient cooling time has elapsed; this to avoid the risk of spontaneous ignition of the oil vapour when air is admitted.  
  
Never use a light source with open flame for inspecting the interior of a machine, pressure vessel, etc.
- 8 Make sure that no tools, loose parts or rags are left in or on the unit.
- 9 Before clearing the unit for use after maintenance or overhaul, check that operating pressures, temperatures and time settings are correct and that the control and shut-down devices function correctly. If removed, check that the coupling guard of the compressor drive shaft has been reinstalled.
10. Every time the separator element is renewed, examine the discharge pipe and the inside of the oil separator vessel for carbon deposits; if excessive, the deposits should be removed.
11. Protect the motor, air filter, electrical and regulating components, etc. to prevent moisture from entering them, e.g. when steam-cleaning.
12. Make sure that all sound-damping material, e.g. on the bodywork and in the air inlet and outlet systems of the compressor, is in good condition. If damaged, replace it by genuine Atlas Copco material to prevent the sound pressure level from increasing.
13. Never use caustic solvents which can damage materials of the air net, e.g. polycarbonate bowls.
14. The following safety precautions are stressed when handling refrigerant:
  - a Never inhale refrigerant vapours. Check that the working area is adequately ventilated; if required, use breathing protection.
  - b Always wear special gloves. In case of refrigerant contact with the skin, rinse the skin with water. If liquid refrigerant contacts the skin through clothing, never tear off or remove the latter; flush abundantly with fresh water over the clothing until all refrigerant is flushed away; then seek medical first aid.
  - c Always wear safety glasses.
15. Protect hands to avoid injury from hot machine parts, e.g. during draining of oil.

### Maintenance

Maintenance and repair work shall only be carried out under supervision of someone qualified for the job.

- 1 Use only the correct tools for maintenance and repair work.
- 2 Use only genuine spare parts.
- 3 All maintenance work, other than routine attention, shall only be undertaken when the unit is stopped, the main power supply is switched off and the machine has cooled down. Take positive precaution to ensure that the unit cannot be started inadvertently.

In addition, a warning sign bearing a legend such as "work in progress; do not start" shall be attached to the starting equipment.

- 4 Before removing any pressurized component, effectively isolate the unit from all sources of pressure and relieve the entire system of pressure.

Note: With stationary machine units driven by an internal combustion engine, allowance has to be made for extra safety precautions, e.g. spark arrestors, fuelling care, etc. Consult Atlas Copco.

All responsibility for any damage or injury resulting from neglecting these precautions, or by non-observance of ordinary caution and due care required in handling, operating, maintenance or repair, even if not expressly mentioned in this book, will be disclaimed by Atlas Copco.