



# AQS System for AVANCE III HD

Technical Manual

Version 001



Copyright© by Bruker Corporation

All rights reserved. No part of this publication may be reproduced, stored in a retrieval system, or transmitted, in any form, or by any means without the prior consent of the publisher. Product names used are trademarks or registered trademarks of their respective holders.

This manual was written by

Arthur Schwilch, Christoph Schumacher, Balz Odermatt,  
Marcel Wattinger, Michael Schenkel

© June 19, 2012: Bruker Corporaton

Fällanden, Switzerland

P/N: Z33083

DWG-Nr.: Z4D12021 Version 001

---

<b>1</b>	<b>About .....</b>	<b>13</b>
1.1	This Manual.....	13
1.2	Policy Statement .....	13
1.3	Symbols and Conventions.....	13
<b>2</b>	<b>Introduction.....</b>	<b>15</b>
2.1	Limitation of Liability .....	15
2.2	Before You Begin .....	15
2.3	Minimum Qualifications for Operating Personnel.....	15
2.4	The Bruker Service.....	16
2.5	Transport to Manufacturer .....	16
<b>3</b>	<b>Safety.....</b>	<b>17</b>
3.1	Intended Use .....	17
3.2	Owner's Responsibility .....	17
3.3	Personnel Requirements.....	19
	Qualifications.....	19
	Unauthorized Persons.....	19
3.4	Personal Protective Equipment .....	19
3.5	Basic Dangers.....	20
<b>4</b>	<b>Technical Data .....</b>	<b>21</b>
4.1	Product Name and Part Number .....	21
4.2	General Information.....	21
4.3	Connection Values .....	22
4.4	Operating Conditions.....	22
4.5	Rating Plate.....	22
<b>5</b>	<b>IPSO Acquisition System.....</b>	<b>23</b>
5.1	Introduction.....	23
	Features of the AQS/3+ System .....	24
	Acquisition Control .....	24
	Analog to Digital Conversion .....	24
5.2	The Channel Concept .....	25
5.3	AQS/3+ Signal and Information Paths .....	27
	Basics of the AQS/3+ Chassis .....	27
	Communication inside the AQS/3+ Chassis .....	27
	Intra Rack Bus.....	29
	Synchronous Serial Rack Bus (SSRB) .....	29
	I2C buses and I2C addresses .....	29
	High Speed Link.....	29
	Sample Info .....	29

5.4	Synchronous Signals.....	30
	Real-time Control-pulses (RCP) on the AQS/3 User Bus .....	30
5.5	Receiver Pulse Separation for Multiple-Receiver Systems .....	36
5.6	RF Signal Paths .....	36
5.7	20 MHz Clock Distribution .....	37
<b>6</b>	<b>AVANCE III HD Configurations.....</b>	<b>39</b>
	Rackcode Setting .....	39
6.1	A Typical 2 to 3 Channel AV III HD HR (Internal IPSO) .....	40
	Bill of Material .....	40
	Rackcode Setting .....	41
	Board Location .....	41
6.2	A Typical 2 to 6 Channel AV III HD HR & Solids (ext. IPSO) .....	42
	Bill of Material .....	42
	Rackcode Setting .....	43
	Board Location .....	43
6.3	A Typical 2 Channel AV III HD HR Multi-RX (2 RX/TX) .....	44
	Bill of Material .....	44
	Rackcode Setting .....	45
	Board Location .....	45
	LO2 Splitter and AUX Combiner .....	46
6.4	A Typical 4 Channel AV III HD HR Multi-RX (2+2 RX/TX) .....	47
	Bill of Material .....	47
	Rackcode Setting .....	48
	Board Location .....	49
	20 MHz, REF and LO2 Distribution .....	49
6.5	A Typical 6 Channel AV III HD HR Multi-RX (2+2+2 RX/TX) .....	50
	Bill of Material .....	50
	Rackcode Setting .....	52
	Board Location .....	53
6.6	A Typical 1 Channel AV III HD PharmaScan with 1 RX .....	54
	Bill of Material .....	54
	Rackcode Setting .....	55
	Board Location .....	55
6.7	A Typical 2 Channel AV III HD BioSpec (2-4 TX / 1 RX).....	56
	Bill of Material .....	56
	Rackcode Setting .....	57
	Board Location .....	57
6.8	A Typical 2 Channel AV III HD BioSpec with mRX Option (2 TX / 4,8,16 RX) ....	58
	Bill of Material .....	58
	Rackcode Setting .....	60
	Board Location .....	61
6.9	A Typical 2 Channel AV III HD BioSpec with pTX Option (8 TX / 2 RX) .....	62

	Bill of Material.....	62
	Rackcode Setting .....	63
	Board Location .....	64
	20 MHz, LO2 and REF Distribution .....	64
	Upgrade with mRX Options (4/8/16 RX) .....	65
6.10	A Typical 2 Channel AV III HD Dual RX Low and High Field .....	66
	Bill of Material.....	66
	Rackcode Setting .....	67
	Board Location .....	67
<b>7</b>	<b>AQS/3+ Mainframe.....</b>	<b>69</b>
7.1	Introduction.....	69
7.2	Front View .....	70
7.3	Rear View.....	71
7.4	AC Power Line Fuses.....	72
7.5	Power-Up Delay .....	72
7.6	Inrush Current Limiter.....	72
7.7	Mains Power Failure & Restart Timeout.....	72
7.8	Diagnostics & Setup .....	73
7.9	Safety Stop.....	74
7.10	AC Wiring .....	75
7.11	Backplane (User Bus) .....	76
	Pulse Switch for Receiver Pulse Separation .....	77
	Rackcode Settings .....	77
7.12	Fans .....	78
7.13	AC/DC Power Supply .....	79
	Product and Part Number .....	79
7.14	Power Supply Service Instruction.....	79
	PSM-48V removal .....	79
	PSM-48V reassembly .....	80
<b>8</b>	<b>AQS/2-M Mainframe.....</b>	<b>81</b>
8.1	Introduction.....	81
8.2	Front View .....	82
8.3	Rear View.....	83
8.4	AC Power Line Fuses.....	84
8.5	Power-Up Delay .....	84
8.6	Inrush Current Limiter.....	84
8.7	Mains Power Failure.....	84
8.8	Diagnostics & Setup .....	85
8.9	Safety Stop.....	86
8.10	AC Wiring .....	87

# Table of Contents

8.11	Backplane (User Bus) .....	89
	Pulse Switch for Receiver Pulse Separation .....	90
	Rackcode Settings .....	90
8.12	Fans .....	91
<b>9</b>	<b>Power Supply System .....</b>	<b>93</b>
9.1	System Overview .....	93
	AQS/3+ Chassis PSM .....	93
	AQS/2-M Chassis PSM .....	94
	PSM Summary Table .....	94
9.2	AQS PSM-48V 600W POWER SUPPLY UNIT .....	95
9.3	AQS PSM-A2 POWER SUPPLY MODULE .....	96
	AQS PSM-A POWER SUPPLY MODULE .....	97
9.4	AQS PSM-D POWER SUPPLY MODULE .....	98
9.5	AQS POWER SUPPLY DIGITAL .....	99
9.6	AQS PSM1 POWER SUPPLY MODULE .....	100
9.7	AQS PSM5 POWER SUPPLY MODULE .....	101
9.8	AQS PSM HPLNA .....	102
9.9	AQS PSM ADM .....	103
9.10	AQS POWER SUPPLY BLA 28V 20A .....	104
<b>10</b>	<b>AQS REF/3.....</b>	<b>105</b>
10.1	Introduction.....	105
10.2	Description .....	105
	Overall Synchronisation .....	106
	Cable Lengths .....	107
	Bus Interfaces .....	107
10.3	Unit Configuration / Jumpers.....	107
	Differences to Previous Version .....	108
10.4	Front Panel Wiring / Display .....	108
10.5	Part Numbers .....	112
10.6	Troubleshooting / Unit replacement / Tips'n Tricks .....	112
10.7	Specifications .....	112
10.8	Power Supply .....	112
	Backplane Connector .....	113
<b>11</b>	<b>AQS RXAD/2.....</b>	<b>115</b>
11.1	Introduction.....	115
11.2	Functions/Description.....	115
	Power Supply and Monitoring .....	117
	Reset .....	117
	Real Time Pulses .....	117

	Effective Gain of the AQS RXAD/2 .....	119
11.3	Unit Configuration / Version / Jumpers.....	120
	Differences to Previous Receiver Versions.....	120
11.4	Front Panel Wiring / Display.....	121
	LED Display .....	122
	Front Panel Connectors .....	123
11.5	Part Numbers .....	124
11.6	Troubleshooting / Unit Replacement / Tips 'n' Tricks .....	124
	General .....	124
	Download new AQS Receiver (RX) Firmware .....	124
	Error Messages.....	125
11.7	Diagnostic Tests.....	128
11.8	DC Offset and Quadrature Correction Table.....	128
11.9	Quadrature Phase/Gain Adjust – Useful Pulse Programs.....	133
11.10	Specifications .....	136
	Timing Definitions.....	137
11.11	Power Supply / Fuses .....	138
	Backplane Connector.....	138
11.12	RXAD/2 Accessory.....	140
	MRI Array-Preamp Supply 10V.....	140
<b>12</b>	<b>AQS DRU.....</b>	<b>141</b>
12.1	Introduction.....	141
12.2	Functions/Description.....	142
	Power Supply and Monitoring LEDs .....	144
	Front Panel Wiring / Display.....	144
	Reset and Operation LED Display .....	144
12.3	Servicing the DRU.....	146
	Accessing the DRU .....	146
	Downloading New Firmware .....	147
12.4	Technical Data .....	148
12.5	Backplane Connectors .....	150
<b>13</b>	<b>AQS SGU/3.....</b>	<b>151</b>
13.1	Introduction.....	151
13.2	Functions/Description.....	151
	Important Functions .....	151
	LO Signal Routing .....	152
	Signal Generation Inside the SGU/3.....	152
	RF Routing Inside the SGU/3.....	154
	Intelligent Pulse Generation .....	155
13.3	Front Panel Wiring / Display.....	157

# Table of Contents

	LED Display.....	158
	Front Panel Connectors .....	159
13.4	SGU/3 FPGA Firmware.....	160
	SGU/3 Firmware Version Encoding .....	160
	Identification of the Firmware Release .....	160
	SGU/3 Firmware Download.....	160
13.5	Part Numbers .....	160
13.6	Error Messages .....	160
13.7	Important Signals .....	163
13.8	Specifications .....	164
	Timing.....	164
	Frequency .....	164
	Phase .....	164
	Amplitude .....	165
	Hardware Response.....	165
13.9	Power Supply / Fuses .....	167
	Backplane Connector .....	167
<b>14</b>	<b>AQS Pulse &amp; RF-Splitter .....</b>	<b>169</b>
14.1	Introduction.....	169
14.2	Functions/Description .....	169
	20MHz Clock and RX-Pulse Distribution.....	169
	LO- & LO2-Splitter.....	170
14.3	RF and Pulse Wiring .....	171
14.4	Front Panel.....	172
	LED Indicators.....	173
	Front Panel Connectors PULSE SPLITTER .....	173
	Front Panel Connectors RF-SPLITTER .....	174
14.5	Diagnostics.....	175
14.6	RF-Splitter Setup and Gain Adjust .....	176
	Setup .....	176
	Gain Adjust.....	177
14.7	Part Numbers and Cables .....	177
	Technical Data .....	178
	PULSE SPLITTER .....	178
	RF-SPLITTER .....	178
14.8	Power Supply / Fuses .....	179
	Backplane Connector .....	179
<b>15</b>	<b>AQS 2H TX.....</b>	<b>181</b>
15.1	Function/Description.....	181
15.2	Front Panel.....	182



15.3	Part Numbers .....	182
15.4	Technical Data .....	183
<b>16</b>	<b>AQS 1 to 4 Router .....</b>	<b>185</b>
16.1	Introduction.....	185
16.2	Functions/Description.....	185
	Switching 1 to 4.....	185
	Tune Signal .....	186
	Bus Interfaces .....	186
16.3	Front Panel Wiring / Display.....	186
	Power LED .....	187
16.4	Backplane Connector .....	188
16.5	Part Numbers and Cables .....	188
16.6	Troubleshooting / Unit replacement / Tips 'n' Tricks .....	189
16.7	Power Supply / Fuses .....	189
<b>17</b>	<b>AQS Controller.....</b>	<b>191</b>
17.1	Introduction.....	191
17.2	AQS Address Mapping.....	191
17.3	Identify Your Chassis Configuration .....	193
	AQS Service Web .....	193
	AQS Board Type Codes.....	193
17.4	New Configuration of the AQS Amplifiers .....	196
	Default Values.....	196
	Adding Housing Setting (Via AQS Service Web) .....	197
17.5	AQS Service Web .....	198
<b>18</b>	<b>Transport, Packaging and Storage .....</b>	<b>201</b>
18.1	Symbols on the Packaging.....	201
18.2	Inspection at Delivery .....	202
18.3	Packaging.....	202
18.4	Storage.....	203
<b>19</b>	<b>Installation and Initial Commissioning.....</b>	<b>205</b>
19.1	Installation in Cabinet.....	205
	Air Ventilation .....	205
	Power Cable.....	206
19.2	Initial Commissioning .....	206
	AQS/2-M chassis Mains Selector.....	206
<b>20</b>	<b>Maintenance.....</b>	<b>207</b>
20.1	Safety .....	207

# Table of Contents

20.2	General.....	207
20.3	Software .....	207
20.4	Cleaning .....	207
20.5	Maintenance Work .....	208
	Fan Tray Service Instructions.....	208
	Fan Tray Removal.....	208
	Fan Tray Reassembly .....	209
<b>21</b>	<b>Dismantling and Disposal.....</b>	<b>211</b>
21.1	Safety .....	211
21.2	Dismantling.....	212
21.3	Disposal Instructions .....	212
<b>A</b>	<b>Appendix .....</b>	<b>213</b>
A.1	Warning Signs .....	213
A.2	Figures .....	215
A.3	Tables.....	219

# Contact

## Manufacturer

The individual units of the AQS system are manufactured at different BRUKER production sites. The manufacturer can be identified by the part number prefix according to the following table.

Part No. Prefix	Z . . . . .	H . . . . .	W . . . . .
Manufacturer Address	<b>Bruker BioSpin AG</b> Industriestr. 26 8117 Fällanden <b>Switzerland</b>	<b>Bruker BioSpin GmbH</b> Silberstreifen 4 76287 Rheinstetten <b>Germany</b>	<b>Bruker BioSpin S.A.</b> 34, rue de l'industrie 67166 Wissembourg Cédex <b>France</b>
Phone	+41 (44) 825 91 11	+49 (721) 5161 - 0	+33 (3) 88 73 68 00
Fax	+41 (44) 825 96 96	+49 (721) 5171 01	+33 (3) 88 73 68 79
E-Mail	sales@bruker-biospin.ch	nmr@bruker-biospin.de	bruker@bruker.fr
Internet	<a href="http://www.bruker-biospin.com">http://www.bruker-biospin.com</a>		

## NMR Hotlines

Contact our NMR service centers.

Bruker BioSpin NMR provide dedicated hotlines and service centers, so that our specialists can respond as quickly as possible to all your service requests, applications questions, software or technical needs.

Please select the NMR service center or hotline you wish to contact from our list available at:

[http://www.bruker-biospin.com/hotlines\\_nmr.html](http://www.bruker-biospin.com/hotlines_nmr.html)



# 1 About

## 1.1 This Manual

---

This manual is intended to be a reference guide for operators and service technicians. It provides detailed information about the user level maintenance and service and overall use of the Bruker device.

The figures shown in this manual are designed to be general and informative and may not represent the specific Bruker model, component or software/firmware version you are working with. Options and accessories may or may not be illustrated in each figure.

**Carefully read all relevant chapters before working on the device!**

This manual describes parts and procedures relevant to the device version it is delivered with. For older hardware, please refer to the manual supplied at the time.

## 1.2 Policy Statement

---

It is the policy of Bruker to improve products as new techniques and components become available. Bruker reserves the right to change specifications at any time.

Every effort has been made to avoid errors in text and figure presentation in this publication. In order to produce useful and appropriate documentation, we welcome your comments on this publication. Support engineers are advised to regularly check with Bruker for updated information.

Bruker is committed to providing customers with inventive, high quality products and services that are environmentally sound.

## 1.3 Symbols and Conventions

---

Safety instructions in this manual are marked with symbols. The safety instructions are introduced using indicative words which express the extent of the hazard.

In order to avoid accidents, personal injury or damage to property, always observe safety instructions and proceed with care.



**! DANGER**

This combination of symbol and signal word indicates an immediately hazardous situation which could result in death or serious injury unless avoided.



## **WARNING**

This combination of symbol and signal word indicates a potentially hazardous situation which could result in death or serious injury unless avoided.



## **CAUTION**

This combination of symbol and signal word indicates a possibly hazardous situation which could result in minor or slight injury unless avoided.

## **NOTICE**

This combination of symbol and signal word indicates a possibly hazardous situation which could result in damage to property or the environment unless avoided.



This symbol highlights useful tips and recommendations as well as information designed to ensure efficient and smooth operation.

## 2 Introduction

This manual is intended to be used by trained device users. It contains information about the device: operation, safety, maintenance, etc..

### 2.1 Limitation of Liability

---

All specifications and instructions in this manual have been compiled taking account of applicable standards and regulations, the current state of technology and the experience and insights we have gained over the years.

The manufacturer accepts no liability for damage due to:

- Failure to observe this manual
- Improper use
- Deployment of untrained personnel
- Unauthorized modifications
- Technical modifications
- Use of unauthorized spare parts

The actual scope of supply may differ from the explanations and depictions in this manual in the case of special designs, take-up of additional ordering options, or as a result of the latest technical modifications.

The undertakings agreed in the supply contract as well as the manufacturer's Terms and Conditions and Terms of Delivery and the legal regulations applicable at the time of conclusion of the contract shall apply.

### 2.2 Before You Begin

---

This user manual contains information and safety information that are necessary for the safe operation of the device.

Any user maintenance and repairs are to be accomplished using the information in this manual.

Consider all safety references!

Information for ordering spare parts is available in the spare parts section for from the Bruker Service Center (see contacts).

### 2.3 Minimum Qualifications for Operating Personnel

---

**EXAMPLE:**

Type of Task	Personnel	Training and Experience
Transportation	No special requirements.	No special.
Installation	Bruker certified personnel only.	Technically skilled, with a good knowledge of the application field.
Routine Use	Appropriately certified and experienced personnel, familiar with use of computers and automation in general	Laboratory technicians or equivalent. Training is usually done in-house. Familiar with MS Windows® environment.
Daily Maintenance		
Setup and optimization of program	Bruker certified personnel only.	Experienced laboratory technician. High degree of knowledge of the relevant application field.
Preventive Maintenance	Bruker certified personnel only.	Technically skilled with a basic understanding of the application.
Servicing	Bruker certified personnel only.	Background and experience in electronics/mechanics with computer knowledge.

Table 2.1 Overview Installation and Operation Requirements for Personnel

## 2.4 The Bruker Service

Our customer service division is available to provide technical information. See "[Contact](#)" on [page 11](#) for contact details.

In addition, our employees are always interested in acquiring new information and experience gained from practical application; such information and experience may help improve our products.

## 2.5 Transport to Manufacturer

When the AQS/3+ mainframe or a subunit must be returned to the manufacturer for a major repair, use the original packaging for transportation.

Include a good description of the problem.



# 3 Safety

This section provides an overview of all the main safety aspects involved in ensuring optimal personnel protection and safe and smooth operation.

Non-compliance with the action guidelines and safety instructions contained in this manual may result in serious hazards.

## 3.1 Intended Use

---

The AQS system has been designed and constructed solely for the intended use as the acquisition system of the *AVANCE III* spectrometers of BRUKER.

Intended use also includes compliance with all specifications in this manual.

- ▶ Any use which exceeds or differs from the intended use shall be considered improper use.
- ▶ No claims of any kind for damage will be entertained if such claims result from improper use.

## 3.2 Owner's Responsibility

---

### Owner

The term 'owner' refers to the person who himself operates the AQS system for trade or commercial purposes, or who surrenders the AQS system to a third party for use/application, and who bears the legal product liability for protecting the user, the personnel or third parties during the operation.

### Owner's Obligations

The AQS system is used in the industrial sector, universities and research laboratories. The owner of the AQS system must therefore comply with statutory occupational safety requirements.

In addition to the safety instructions in this manual, the safety, accident prevention and environmental protection regulations governing the operating area of the AQS system must be observed.

In this regard, the following requirements should be particularly observed:

- The owner must obtain information about the applicable occupational safety regulations, and - in the context of a risk assessment - must determine any additional dangers resulting from the specific working conditions at the usage location of the device. The owner must then implement this information in a set of operating instructions governing operation of the AQS system.

- During the complete operating time of the AQS system, the owner must assess whether the operating instructions issued comply with the current status of regulations, and must update the operating instructions if necessary.
- The owner must clearly lay down and specify responsibilities with respect to installation, operation, troubleshooting, maintenance and cleaning.
- The owner must ensure that all personnel dealing with the AQS system have read and understood this manual. In addition, the owner must provide personnel with training and hazards information at regular intervals.
- The owner must provide the personnel with the necessary protective equipment.
- The owner must warrant that the AQS system is operated by trained and authorised personnel as well as all other work, as transportation, mounting, start-up, the installation, maintenance, cleaning, service, repair and shutdown, that is carried out on the AQS system.
- All personnel who work with, or in the close proximity of the AQS system, need to be informed of all safety issues and emergency procedures as outlined in this user manual.
- The owner must document the information about all safety issues and emergency procedures in a laboratory SOP (Standard Operating Procedure). Routine briefings and briefings for new personnel must take place.
- The owner must ensure that new personnel must be supervised by experienced personnel. It is highly recommended to implement a company training program for new personnel on all aspects of product safety and operation.
- The owner must ensure that personnel is regularly informed of the potential hazards within the laboratory. This is all personnel that work in the area, but in particular laboratory personnel and external personnel such as cleaning and service personnel.
- The owner is responsible for taking measures to avoid inherent risks in the handling of dangerous substances, preventing industrial disease, and providing medical first aid in emergencies.
- The owner is responsible for providing facilities according to the local regulations for the prevention of industrial accidents and generally accepted safety regulations according to the rules of occupational medicine.
- All substances needed for operating and cleaning the AQS system, solvents, cleaning agents, gases, etc. have to be handled with care and disposed of appropriately. All hints and warnings on storage containers must be read and adhered to.
- The owner must ensure that the work area is sufficiently illuminated to avoid reading errors and faulty operation.

Furthermore, the owner is responsible for ensuring that the AQS system is always in a technically faultless condition. Therefore, the following applies:

- The owner must ensure that the maintenance intervals described in this manual are observed.
- The owner must ensure that all safety devices are regularly checked to ensure full functionality and completeness.

## 3.3 Personnel Requirements

---

### 3.3.1 Qualifications

---

**i** Note: Only trained Bruker personnel are allowed to mount, retrofit, repair, adjust and dismantle the AQS system!

---

This manual specifies the personnel qualifications required for the different areas of work, listed below:

#### Laboratory Personnel

Laboratory personnel are health care professionals, technicians, and assistants staffing a research or health care facility where specimens are grown, tested, or evaluated and the results of such measures are recorded. Laboratory personnel are able to carry out assigned work and to recognize and prevent possible dangers self-reliant due to their professional training, knowledge and experience as well as profound knowledge of applicable regulations.

The workforce must only consist of persons who can be expected to carry out their work reliably. Persons with impaired reactions due to, for example, the consumption of drugs, alcohol, or medication are prohibited from carrying out work on the device.

When selecting personnel, the age-related and occupation-related regulations governing the usage location must be observed.

### 3.3.2 Unauthorized Persons

---

#### WARNING



#### **Risk to life for unauthorized personnel due to hazards in the danger and working zone!**

Unauthorized personnel who do not meet the requirements described in this manual will not be familiar with the dangers in the working zone. Therefore, unauthorized persons face the risk of serious injury or death.

- ▶ Unauthorized persons must be kept away from the danger and working zone.
- ▶ If in doubt, address the persons in question and ask them to leave the danger and working zone.
- ▶ Cease work while unauthorized persons are in the danger and working zone.

## 3.4 Personal Protective Equipment

---

Personal protective equipment is used to protect the personnel from dangers which could affect their safety or health while working.

The personnel must wear personal protective equipment while carrying out the different operations at and with the device.

This equipment will be defined by the head of laboratory. Always comply with the instructions governing personal protective equipment posted in the work area.

## 3.5 Basic Dangers

---

The following section specifies residual risks which may result from using the AQS system and have been established by means of a risk assessment.

In order to minimize health hazards and avoid dangerous situations, follow the safety instructions specified here as well as in the following chapters of this manual.

# 4 Technical Data

**i** The technical data for the AQS/3+ and the AQS/2-M chassis are generally the same. Exceptions are noted specifically.

## 4.1 Product Name and Part Number

Name	Part Number
AQS/3+ CHASSIS WIRED	Z120343
AQS/2-M CHASSIS WIRED	Z103493

Table 4.1 Product name and part number

**i** Product names and part numbers of subunits see ["AVANCE III HD Configurations"](#) or the appropriate subunit chapter of this manual.

## 4.2 General Information

Data	Value	Unit
Weight: without subunits <sup>a</sup>	10	kg
Weight: with subunits	40 - 50	kg
Length	570	mm
Width	483	mm
Height	310	mm
IEC protection class	Class I	-
Overvoltage protection category	CAT II	-
Pollution degree	2	-
Ingress protection class (IEC 60259)	IP 20	-
Conformity IEC/EN	61010-1	-

Table 4.2 Technical data: General information

a. AQS/2-M chassis = 20 kg

## 4.3 Connection Values

Data	Value	Unit
Voltage <sup>a</sup>	208-230	V~
Input current	max. 8.0	A
Input inrush current	max. 20	Apk
Circuit protection: Fuse <sup>b</sup>	8.0	A
Frequency	50 / 60	Hz

Table 4.3 Technical data: Electrical connection values

a. AQS/2-M chassis = 208 / 220 / 230 V~, voltage range selectable with switch

b. 2 pcs. 5x20mm, 250V~, time-lag T, type H

## 4.4 Operating Conditions

### Environment

Data	Value	Unit
Ambient temperature range	5 - 40	°C
Relative humidity at 31 °C <sup>a</sup>	max. 80	%
Working altitude above sea level	2000	m

Table 4.4 Technical data: Environment conditions

a. Decreasing linear till relative humidity < 50% at 40 °C

## 4.5 Rating Plate



Figure 4.1 AQS/3+ and AQS/2-M chassis rating plate

# 5 IPSO Acquisition System

## 5.1 Introduction

---

The first Acquisition System (named AQS) was introduced into the market in 1999. The main reason was the development of a BRUKER's own synthesizer (SGU) based on a novel channel concept. The architecture of the former AQR and AQX units have been unified, higher integrated and more standardized. During the last years the architecture has been completed with additional and more diversified configurations still based on a unified hardware and software concept. This allowed i.e. to enhance Solids configurations (RX-BB instead of SE451), to develop higher integrated High Resolution spectrometer electronics (AQS integrated LNA preamplifiers instead of HPPR), to offer new MRI solutions (Pharmascan and Biospec with multiple RX) and standardize the FTMS platforms (SGU FTMS).

The 2nd generation (named AVANCE II) was the introduction of a new receiver system. The former RCU, RX-22 and the HADC/2 and SADC were replaced by the new DRU and RXAD (equipped in the also new AQS/2 chassis) which brought a much higher integration and increased performance.

The 3rd step (AVANCE III) was the replacement of the VME boards, such as CCU, FCU, TCU and GCU by the IPSO (intelligent pulse sequence organizer). The AQS/3 chassis can be equipped with an IPSO AQS Unit for systems up to three channels. Systems with more than three channels need the extended IPSO 19" Unit. The IPSO compatible SGU/2 was the successor of the former SGU with a higher bandwidth digital interface for setting all relevant pulse program parameters such as frequency, phase and amplitude at the same time. A package of frequency, phase- and amplitude-words together with some relevant real time pulses can be set synchronously every 25ns via the 80MHz and 48bit wide LVDS link. The setting via the synchronous and differential LVDS link guarantees an excellent isolation between digital computer electronics and purest RF signals.

With the introduction of AVANCE III HD a new and higher integrated digital RF synthesizer SGU/3 is being used for signal generation. It is based on latest digital RF components running at higher clock rates. This new synthesizer is fully compliant with the AVANCE III IPSO but requires different infrastructure (chassis, reference signals, power supply). At the same time a unification of frequency variants has taken place. There are no specific 400 MHz versions anymore.

The new AQS/3+ chassis offers one central 48V AC/DC power supply. All local voltages are derived from this central supply. The SGU/3 incorporates two highly integrated and independent RF channels with increased performance compared to the former SGU/2. The REF/3 generates all the necessary fix-frequencies for the SGU/3 and also synchronizes via a global reset all SGU/3. Therefore even in a complex multi chassis system, only one REF/3 is required.

## 5.1.1 Features of the AQS/3+ System

- Prepared for up to 11 6TE RF and other NMR electronic units
- Full compatibility with the IPSO AQS Unit
- Support of mixed systems (HR, Solids and multiple RX imaging) by a versatile back-plane pulse routing under software control
- Two fully integrated RF synthesizer channels in one single SGU/3 unit
- SGU/3 and REF/3 are available in two frequency versions: SGU/3 600, SGU/3 1200 and REF/3 600, REF/3 1200
- Less dissipated power due to one central 48V AC/DC switched power supply



Figure 5.1 Three Channel configuration for 200 – 600 MHz with AQS IPSO

## 5.1.2 Acquisition Control

The „sample information bus“ is being used for the control of the real-time actions in the digital receiver chain. Synchronous scan information (e.g. receiving phase, file handle, wobble control, accumulation and display management) is distributed over this bus from the acquisition main controller (timing control) via the observe SGU/3 channel to the digital receiver unit (DRU).

## 5.1.3 Analog to Digital Conversion

Newest A/D converter technologies allow sampling rates up to 20MHz with very high



dynamic ranges. In conjunction of the tremendous progress in digital signal processing (DSP technology) and very fast and highly integrated flexible digital hardware (FPGA based) it allows enormous higher DQD bandwidths and with that less audio artefacts as anyone could expect in earlier times.

Automatic DC compensation, higher frequency digital local oscillators (NCO, numeric controlled oscillators) and last but not least better performance is also achieved by continuous A/D converter operation (non start/stop mode). Inherent thermal settling of the A/D chips by using start/stop mode disappears. The DWELL clock is derived directly from the basic phase noise minimized spectrometer reference increasing the spectral purity. Finally the DWELL clock generation for such a system is much easier, because the gating is handled in the DSP by managing the data flow using previously mentioned 'scan control'.

## 5.2 The Channel Concept

---

With the introduction of the AQS/3 Chassis, the well proven AQS channel concept has been further extended by the replacement of the former TCU/FCU and GCU units with the IPSO AQS Unit and IPSO 19" Unit.

It was possible to reduce the control and routing of important channel related real time events and analog signals to only a few dedicated units. All these channel oriented signals (RF signals, shaping, gating and blanking pulses, dwell clocks etc.) are generated in the so called SGU/3 (Signal Generation Unit) under full timing control of pulse programs. The SGU/3 is physically controlled by the IPSO via a digital high speed link.

The following diagram shows the consequent implementation of this concept. The number of analog interconnections is reduced to a few dedicated units. All important RF signals, blanking pulses and dwell clock are channel related and follow a straightforward channel philosophy. In this way, extended and independent multi channel operation can be performed in a much more transparent way. Less interfaces and units allow a general guaranteed stability and reliability.

# IPSO Acquisition System

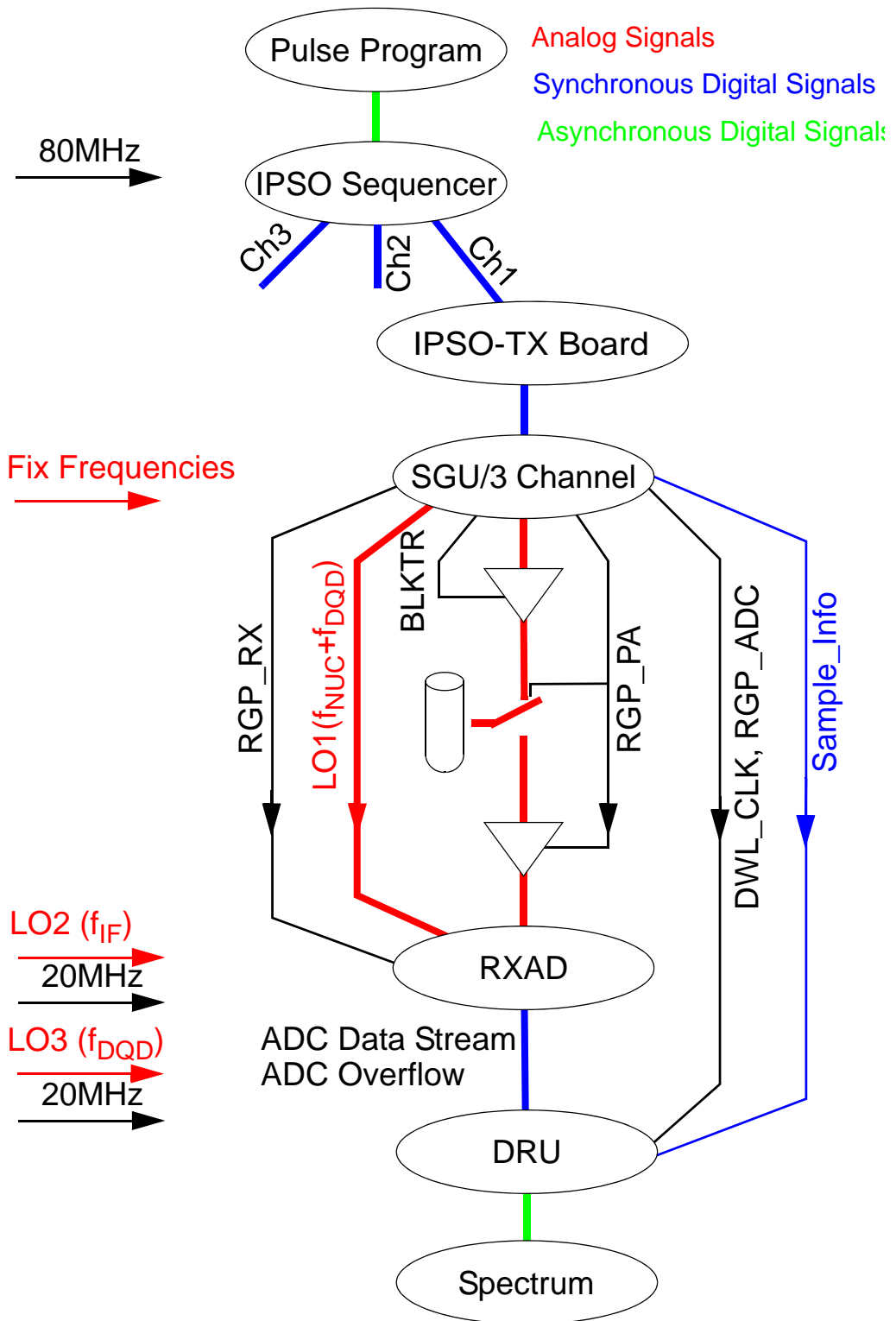

Figure 5.2 AQS channel concept

## 5.3 AQS/3+ Signal and Information Paths

---

Like in the previous versions of the AQS there are three different categories of signals in the AQS/3+ chassis:

### Analog Signals

These signals are typically RF signals, which have no time and amplitude discrete values and may be easily checked with a scope. Examples of such signals are the local oscillator signals (i.e. LO1 and LO2).

### Synchronous Signals

These signals are the basic spectrometer auxiliary, control and timing signals for each transmit but also receive channel. They are all derived from one master oven controlled oscillator (OCXO). Most important are the 10MHz, 20MHz, but also the transmitter blanking and the receiver gating pulses.

### Asynchronous Signals

Asynchronous signals fall into the category of general information transfer protocol signals. These signals are represented by examples like Ethernet, RS232, RS485 and I2C.

### 5.3.1 Basics of the AQS/3+ Chassis

---

The AQS chassis has been designed to allow a very flexible extension of NMR transmitting channels, multireceiving capabilities and setting up numerous different NMR spectrometers configurations. In order to distinguish between different configurations multiple rack codes can be set. The rack code is set by rotary switches on the rear side of the AQS/3+ backplane (see "[Rackcode Settings](#)" on page 77).

Viewing the AQS/3+ chassis from the front, the IPSO connection is on the left side. On the right side there are eleven slots (0 to 10) for different AQS functional units (signal generators, receivers, splitters etc.).

Each slot on the AQS/3+ User Bus backplane is hardware coded, so that each unit can be addressed via its dedicated slot address. The AQS/3+ user bus backplane connector pin assignment is identical for all 6TE slots. Therefore each common signal respectively signal path is accessible on all slots.

### 5.3.2 Communication inside the AQS/3+ Chassis

---

The DRU placed in slot 1 serves as the 'rack master' or AQS Controller. This AQS Controller overtakes general control and configuration tasks during initialization which must be set up according to the rack address. The AQS Controller reacts to 'master' commands (e.g. power up, init...) incoming via the tty10 from the spectrometer control software via ethernet. It also reacts to incoming virtual SBSB commands for devices which do not have an SBSB interface (e.g. SSRB or I2C).

Figure 5.3 shows all communication buses inside the AQS/3+ chassis.

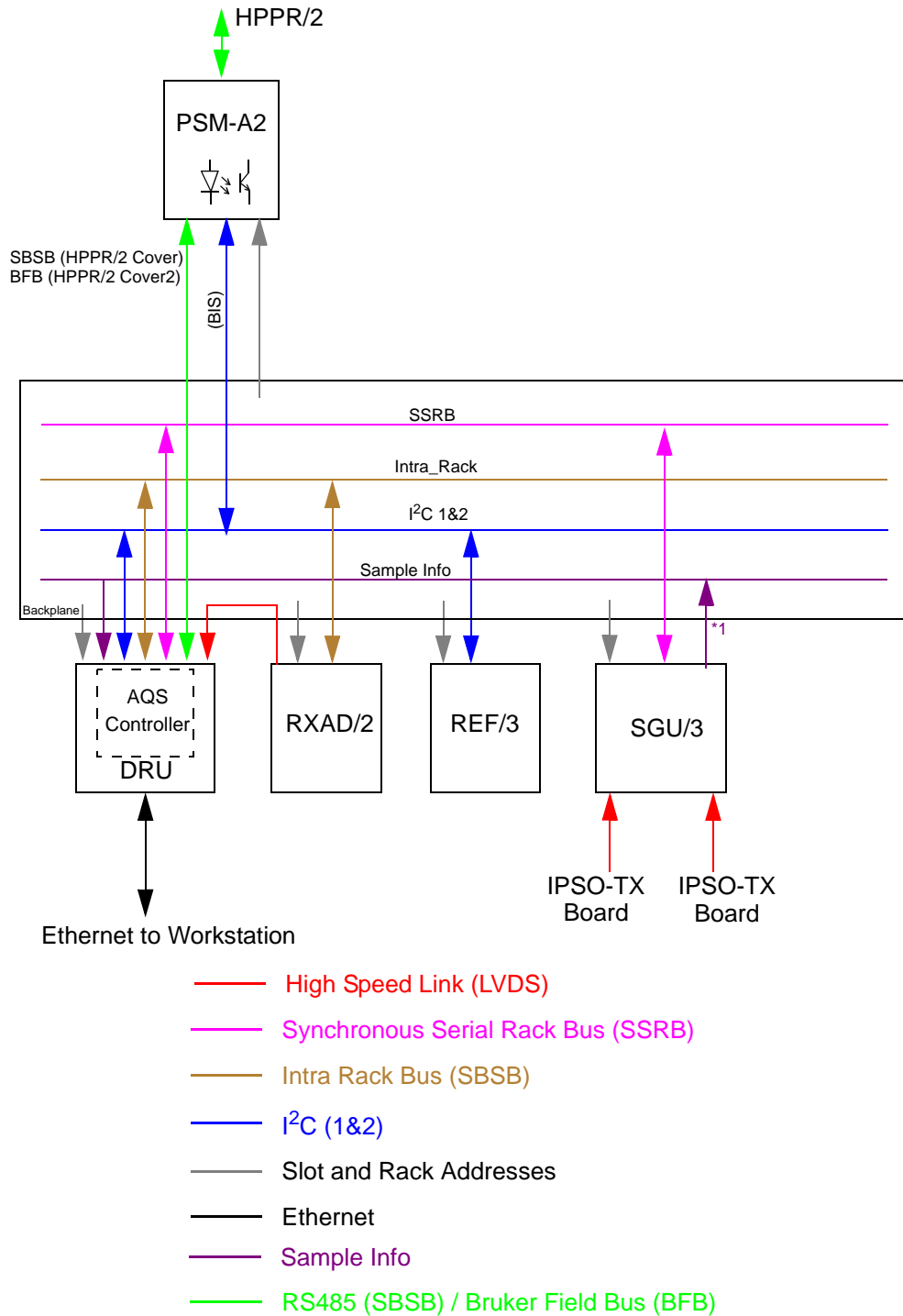

\*1=only active for observe SGU channel

Figure 5.3 AQS/3+ buses for a two channel system

## 5.3.3 Intra Rack Bus

---

The intra rack bus is an internal SBSB (Serial Bruker Spectrospin Bus) based on RS485. In the AQS/3+ chassis it is only used for the communication between AQS controller (DRU in slot 1) and the receiver boards AQS RXAD/2.

## 5.3.4 Synchronous Serial Rack Bus (SSRB)

---

This bus was designed for fast communication with FPGA based units. In the AQS/3+ this bus is used by the new SGU/3 units. All SBSB communication to the SGU/3 is transferred from the AQS controller via SSRB.

## 5.3.5 I<sup>2</sup>C buses and I<sup>2</sup>C addresses

---

The two wire interface I<sup>2</sup>C is used for units without an intelligent and powerful micro controller. The AQS Controller drives these units via different I<sup>2</sup>C buses and thus plays the role of a virtual unit controller for each non microprocessor unit. Such units are the AQS REF/3 and the AQS Pulse Splitter. Incoming spectrometer SBSB commands from tty10 for I2C devices are converted to I2C commands by the AQS Controller.

## 5.3.6 High Speed Link

---

The high speed link (LVDS) from IPSO-TX Board to SGU/3 transfers all NMR relevant real time events derived from the pulse program to the corresponding SGU/3 channel (e.g. pulses, shapes, phase jumps, frequency jumps, etc.). The instructions are synchronously transferred in 12.5 ns time intervals. Each RF channel is connected by a separate high speed link to the IPSO-TX Board. To allow a flexible extension of NMR channels, the wiring is located on the front side of the corresponding boards. To allow highest speed, a point to point connection architecture has been chosen.

Similarly the A/D converter output of a RXAD/2 is coupled to the DRU via its own and well proven LVDS high speed link. This gives the possibility to transfer a complex digital data point (real and imaginary) within 50 ns and allows DWELL clocks up to 20MHz. Because each receiver channel consists of one RXAD/2 and one DRU this link is physically located on the AQS/3 user bus, leading to a minimum of cable connections on the front side.

## 5.3.7 Sample Info

---

A synchronous information mechanism for each acquisition named „sample info“ has been established to control the receiver signal and process chain. It's use makes it possible to handle the receiver phase on the DRU by pulse program commands.

The sample information is stored on the workstation disk together with the acquisition data. This provides full synchronicity of the scans. The acquisition data can easily be traced on the disk file by storing the complete set of ‚sample information‘.

## 5.4 Synchronous Signals

---

### 5.4.1 Real-time Control-pulses (RCP) on the AQS/3 User Bus

---

#### 5.4.1.1 BLKTRx~ (Blanking pulses for power amplifiers)

---

Each BLKTR must be routed to the corresponding power amplifier. A SGU/3 channel can control up to 8 power amplifiers with the corresponding BLKTR. The SGU/3 must be initialized using SBSB commands before starting the experiment. Each SGU/3 channel drives the required BLKTR real time pulse on the AQS/3 User Bus backplane. The BLKTR are combined with wired nor logic on the backplane so that BLKTRs from different SGU/3 units can be combined to one amplifier (easy pulse programming, channel concept).

No additional cables are necessary to control the internal power amplifiers (e.g. AQS 2H-TX). The BLKTR are routed directly on the backplane from the SGU/3 to the corresponding BLA channel. BLKTR for external power amplifiers can be accessed on the front of the power supply PSM-A2.

#### 5.4.1.2 RGP\_HPPR~ (Preamplicifier receiver gating pulse)

---

This pulse (also mentioned as RGP\_PA) is controlled by the SGU/3 channel which is initialized as observing channel. This signal is routed via the PSM-A2 to the observe module in the preamplicifier HPPR/2. All other non lock HPPR/2 modules are in transmit or decoupling mode.

The preamplicifier RGP is also connected to the RXAD/2 for multi receiver configurations only.

#### 5.4.1.3 RGP\_LO~ (Local oscillator gating pulse)

---

This internal pulse enables the local oscillator generation inside the RXAD/2. The pulse is automatically generated by the observe SGU/3 channel after switching to receive mode.

#### 5.4.1.4 RGP\_RX~ (Receiver gating pulse)

---

This pulse controls the gating inside the receiver e.g. the RXAD/2. The pulse is driven by the observe SGU/3 channel. The signal is directly routed from the observe SGU/3 via AQS/3 User Bus backplane to the receiver RXAD/2. With this signal the receiver may be ,opened' later in respect to the preamplicifier to prevent saturation.

## 5.4.1.5 Dwell\_Clk~ (ADC dwell clock)

In fact the Dwell\_Clk~ changed its operational behavior compared to previous AVANCE systems. It serves as a dwell enable and does not reflect the physical AD converter rate. The AD converter rate is fixed to an oversampling frequency of 20MHz, is running continuously and the data stream is enabled (gated) by the Dwell\_Clk~ inside the DRU. The signal is also driven by the observe SGU/3 channel.

## 5.4.1.6 RGP\_ADC~ (ADC gating pulse)

This pulse (also driven by the observe SGU/3 channel) controls the ADC data stream. During inactive RGP\_ADC~ the data stream is filled with zeros inside the DRU. During an active pulse, ADC data is passed unchanged.

This signal is specially used for experiments like digital homodecoupling with oversampling.

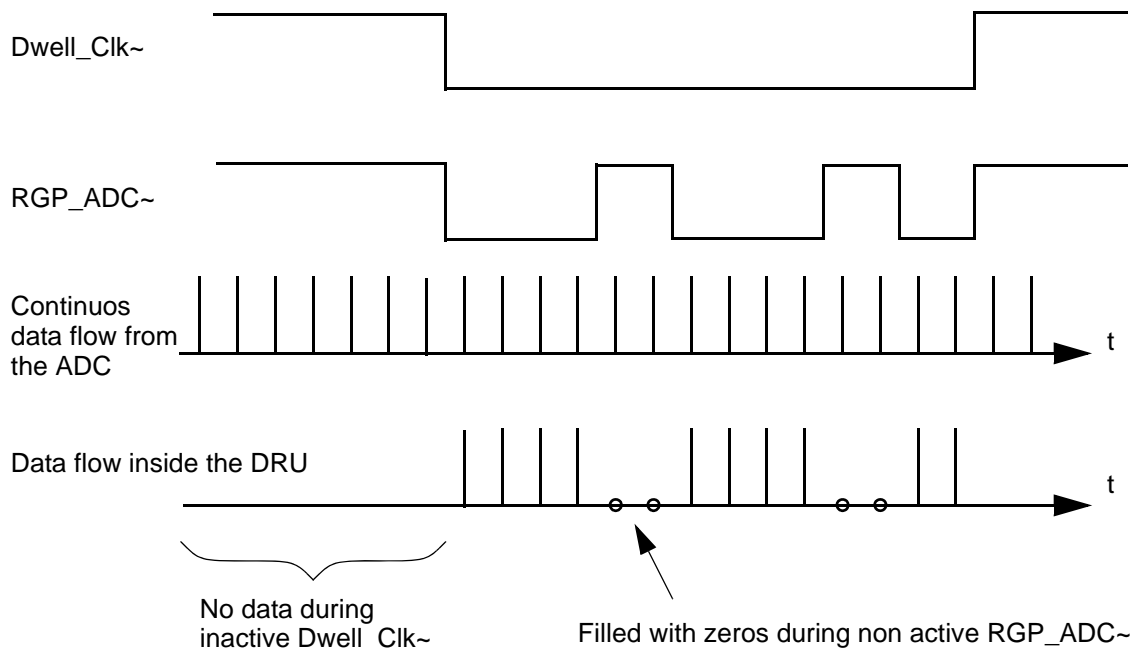

Figure 5.4 Explanation of Dwell\_Clk~ and RGP\_ADC~

## 5.4.1.7 Interleave\_Incr~

This pulse allows to switch between different preloaded modes under pulse program control. E.g. real time switching between 2H lock mode and 2H decoupling mode of the HPPR/2 can be controlled using this pulse or different receiving parameters can be selected during the experiment for interleaved acquisition.

## 5.4.1.8 Sample Info

The Sample Info bus consists of the five lines SAMPLE\_INFO(4:0) driven by the observing SGU/3 channel. The interface is synchronous to the 20 MHz system clock (20MHZ\_CLK) and hence the word rate is 20MW/s.

The scan control commands have a fixed length of 6 words. Bit 4 of the first word carries the start bit which is always 1. Bit 4 of the last word must be set to 0. With that, all listeners to these lines are able to synchronize to the information contained within burst sent under pulse program control.

In between two Sample Info bursts, a recovery time of 10us must be granted.

The information is clustered to two groups, each with an individual enable bit:

The first group (enabled by bit „ScanCtrl“) carries information which must be available before a scan (e.g. scan phase, memory buffer, accumulation control). This information is associated to the upcoming scan.

The second group (enabled by bit „WriteCtrl“) carries information on how to proceed with a scan that has been readily accumulated (e.g. file seek, file change). This information is associated to the past scan.

Word	Bit 4 Pin E3	Bit 3 Pin C2	Bit 2 Pin D2	Bit 1 Pin E2	Bit 0 Pin E1
1	1 (Start)	ScanCtrl	PhaseRun	Phase (0, 90, 180, 270)	
2	reserved=0	st0	st	zd	ze
3	OffsMeas	DruParamIndex			
4	WriteCtrl	FileNumber (0-15)			
5	reserved (set zero)		Write	Seek	
6	0 (Stop)	reserved (set zero)			

Table 5.1 Data format of the 6 sample info words (5 bits each)

### ScanCtrl

Enable bit for the first group. This bit must be set to prepare an upcoming scan.

### PhaseRun

If this bit is set, the phase accumulator immediately starts running (synchronously to the Sample Info). If this bit is cleared, phase accumulation is delayed until Dwell\_Clk~ becomes active for the first time.

### Phase

Accumulation phase.

0 = 0 deg

1 = 90 deg



2 = 180 deg

3 = 270 deg

## **st0 , st**

Controls the memory buffer handling.

st0,st

0,0 accumulate the upcoming scan to the current buffer

0,1accumulate the upcoming scan to the next buffer

1,0accumulate the upcoming scan to the first buffer

1,1reserved

## **zd, ze**

Controls the accumulation.

zd,ze

0,0 add the upcoming scan to the buffer

0,1write the upcoming scan to the buffer

1,0write the upcoming DummyScans+1 scans to the buffer

1,1reserved

## **OffsMeas**

This bit is partially independent of the groups „ScanCtrl“ and „WriteCtrl“ and triggers the DC offset calibration. The filed „DruParamIndex“ is co-used with „ScanCtrl“ but besides of this it is independent of the other two groups.

Dwell\_Clk~ and RGP\_ADC~ must be active for at least 1ms. During this time the DC offset is measured by averaging 16384 ADC samples.

## **DruParamIndex**

These four bits select one out of 16 preloaded acquisition parameter sets. This is intended for interleaved acquisition, where all parameters have to change on the fly. (e.g. SWH, TD, DC offset)

## **WriteCtrl**

Enable bit for the second group. This bit must be set to write a scan to disk.

## **FileNumber**

These four bits select one of 16 disk files to write to or to manipulate the file pointer. Data source is always the memory buffer of the last acquisition.

„FileNumber“ can be chosen independently of the preloaded acquisition parameter sets (addressed by „DruParamIndex“) in the range 0-15.

(DataSetList, ifp, dfp, rfp):

0-12: directly access the files 0-12

13: use current file, then decrement file number

14: use current file, no change

15: use current file, then increment file number

## **Write (wr)**

„Write“ = 1: Write TD\*NBL samples to the file selected by „FileNumber“.

„Write“ = 0: disk file pointer manipulation only.

## **Seek (if,df,rf)**

Manipulate the disk file pointer of the file „FileNumber“.

All 16 disk file pointers are cleared at experiment setup time.

0=none

1=increment disk file pointer by TD\*NBL

2=decrement disk file pointer by TD\*NBL

3=reset disk file pointer

## **SEL\_ADCx~ (Select A/D converter)**

Obsolete.

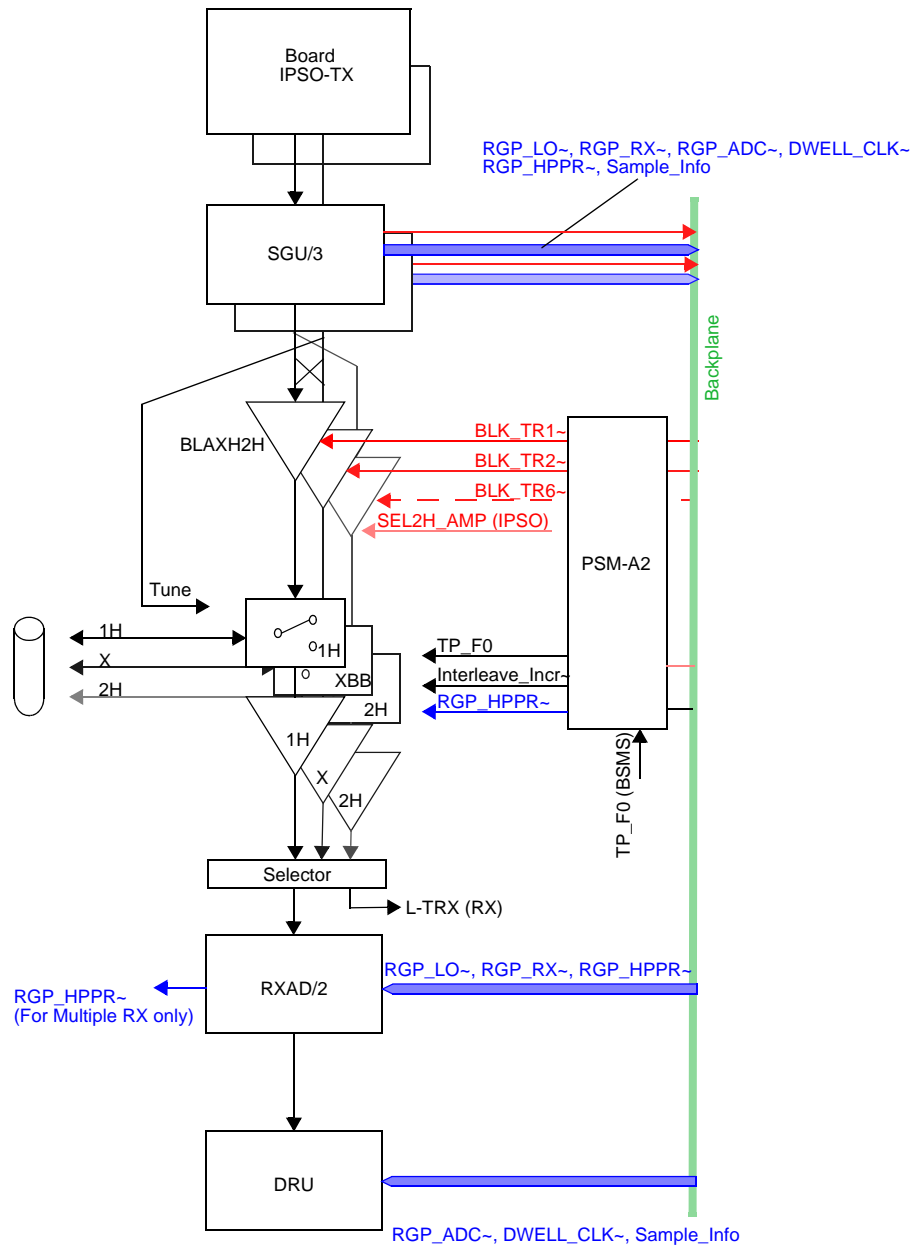

In this configuration three amplifiers exist but only two SGU/3 channels. SGU/3 (2) can either be used for 1H or 2H (for 2H decoupling or 2H shimming). Controlling Lock mode or L-TX mode is done via the signal SEL2H\_AMP from the IPSO.

Figure 5.5 Pulse distribution of a two channel AVANCE III HD

## 5.5 Receiver Pulse Separation for Multiple-Receiver Systems

---

All receiver specific pulses must be separated between receivers in multiple receiver systems. These pulses are:

RGP\_HPPR~, RGP\_LO~, RGP\_RX~, RGP\_ADC~

DWELL\_CLK~

SAMPLE\_INFO(0:4)~, INTERLEAVE\_INCR~

The separation is done with a bus switch on the backplane. The bus switch is controlled by the AQS controller (SBSB) via I<sup>2</sup>C. For details see ["Pulse Switch for Receiver Pulse Separation" on page 77](#).

## 5.6 RF Signal Paths

---

The following RF signals are required in the AQS system:

1. The RF output of each SGU/3 channel must be connected to a power amplifier or to a router/combiner.
2. Each SGU/3 channel can be initialized as observe channel and therefore each SGU/3 channel must be able to drive the local oscillator (LO) signal for the receiver. Every SGU/3 has an LO input and an LO output connector. The LO signal is daisy-chained through all SGU/3 except the observe SGU/3, which is driving the local oscillator.
3. Several fixed frequencies (REF) are generated on the reference board (AQS Reference Board 3). These signals are required for the up-conversion electronics located in the SGU/3. One reference board can drive up to four SGU/3.
4. The 10MHz output of the reference board is used to synchronize various units like the BSMS/2 ELCB. The reference board switches automatically to the external 10MHz input if a signal is applied.
5. The Lock Output of the reference board is connected to the BSMS/2 Lock Transceiver unit.
6. The detection reference signal (LO 2) is directly wired from the reference board to the receiver RXAD/2.

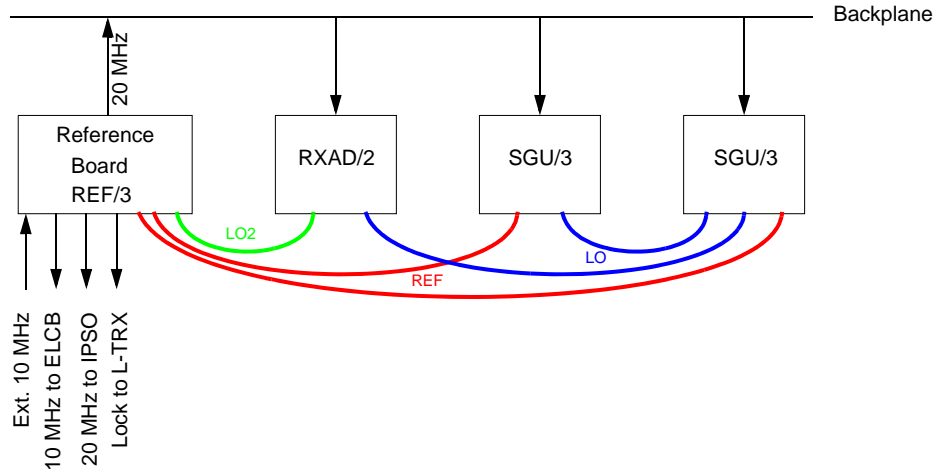

Figure 5.6 RF Distribution

### 5.7 20 MHz Clock Distribution

A synchronous 20 MHz clock signal is distributed to all slots in the AQS chassis. The clock source is given by the reference board in slot 2. shows the clock distribution over the backplane.

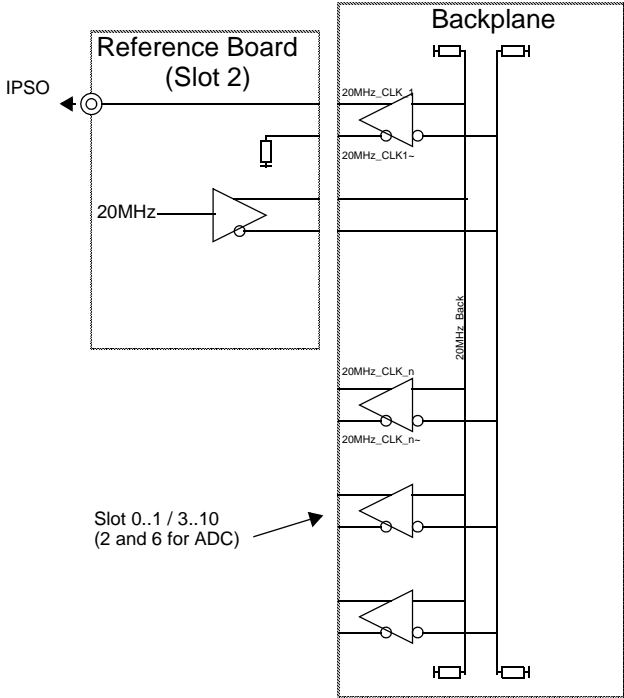

Figure 5.7 20 MHz Clock Distribution



# 6 AVANCE III HD Configurations

Group	Description	TX	RX	Racks	Console	Page
HR	2-3 channel with internal IPSO	2-3	1	1	OB	40
	2-6 channel with external IPSO	2-6	1	1	TB	42
	2 channel multi-receive 2 RX/TX	2	2	1	OB	44
	4 channel multi-receive 2+2 RX/TX	4	4	2	TB	47
	6 channel multi-receive 2+2+2 RX/TX	6	6	3	TB	50
MRI	1 channel PharmaScan	1	1	1	MRI	54
	2 channel BioSpec with 1RX	2	1	1	MRI	56
	2 channel BioSpec with mRX Option (4 / 8 / 16 RX)	2	2-16	2	MRI	58
	2 channel BioSpec with pTX Option (8 TX)	8	2-16	2	MRI	62
Custom	2 channel dual-receive low & high field	2-4	2	1	OB	66

Table 6.1 List of configurations

## 6.0.1 Rackcode Setting

An important element of the chassis configuration is the rackcode setting. To ensure correct operation set the switches according to the table in the configuration description.

The rackcode and power-up delay switches are located on the rear side. The pulse switch for receiver pulse separation is set via the device webpage in the DRU service web.

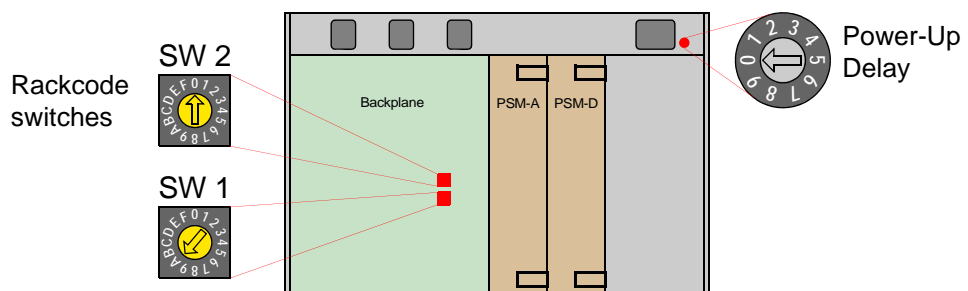

Figure 6.1 AQS/3+ chassis rear view: rackcode switch location

## 6.1 A Typical 2 to 3 Channel AV III HD HR (Internal IPSO)

### 6.1.1 Bill of Material

Pos.	Units	Part Number	Description <i>Channel extension and options written in italics.</i>
1	1	Z120343	AQS/3+ CHASSIS WIRED
2	1	Z121625	AQS PSM-D POWER SUPPLY MODULE
3	1	Z133424	AQS PSM-A2 POWER SUPPLY MODULE
4	1	Z104783	AQS PSM HPLNA
5	1	H9984	IPSO AQS HR UNIT
6	1	Z102520	AQS DRU-E ECL $\geq$ 06
7	1	Z130588	AQS RECEIVER BOARD RXAD/2 600
8	1	Z116985	AQS REFERENCE BOARD/3 600
9	1 (2)	Z117129	AQS SGU/3 600
10	1	<i>Z103550</i> <i>Z103551</i>	<i>AQS 2H-TX BD 200-400</i> <i>AQS 2H-TX BD 500-1000</i>
11	1	<i>Z101247</i>	<i>AQS 1 TO 4 ROUTER</i>
12	1	<i>W1345050</i>	<i>AQS POWER SUPPLY BLA 28V 20A</i>
<b>Mechanical Parts</b>			Mech. parts are components of the assembled chassis. Application and quantity are dependent on options. Only spare parts must be ordered separately.
M1	1	Z2778	FRONTPLATE BLIND 4TE
M2	2	Z12489	FRONTPLATE BLIND 6TE
M3	1	Z14118	FRONTPLATE BLIND 8TE
M4	3	Z12170	FRONTPLATE BLIND 12TE
M5	3	Z14119 Z14120	FRONTPLATE BLIND 1MM 12TE COVERPLATE 8TE
—	26	25958	SCREW RRCH KR M2,5 x 12,3

Table 6.2 Bill of material



## 6.1.2 Rackcode Setting

Rack Nb.	Rackcode	SW2	SW1	Pulse Switch (DRU Device Webpage)	Power-Up Delay
1	0x0A	0	A	closed (default)	0

## 6.1.3 Board Location

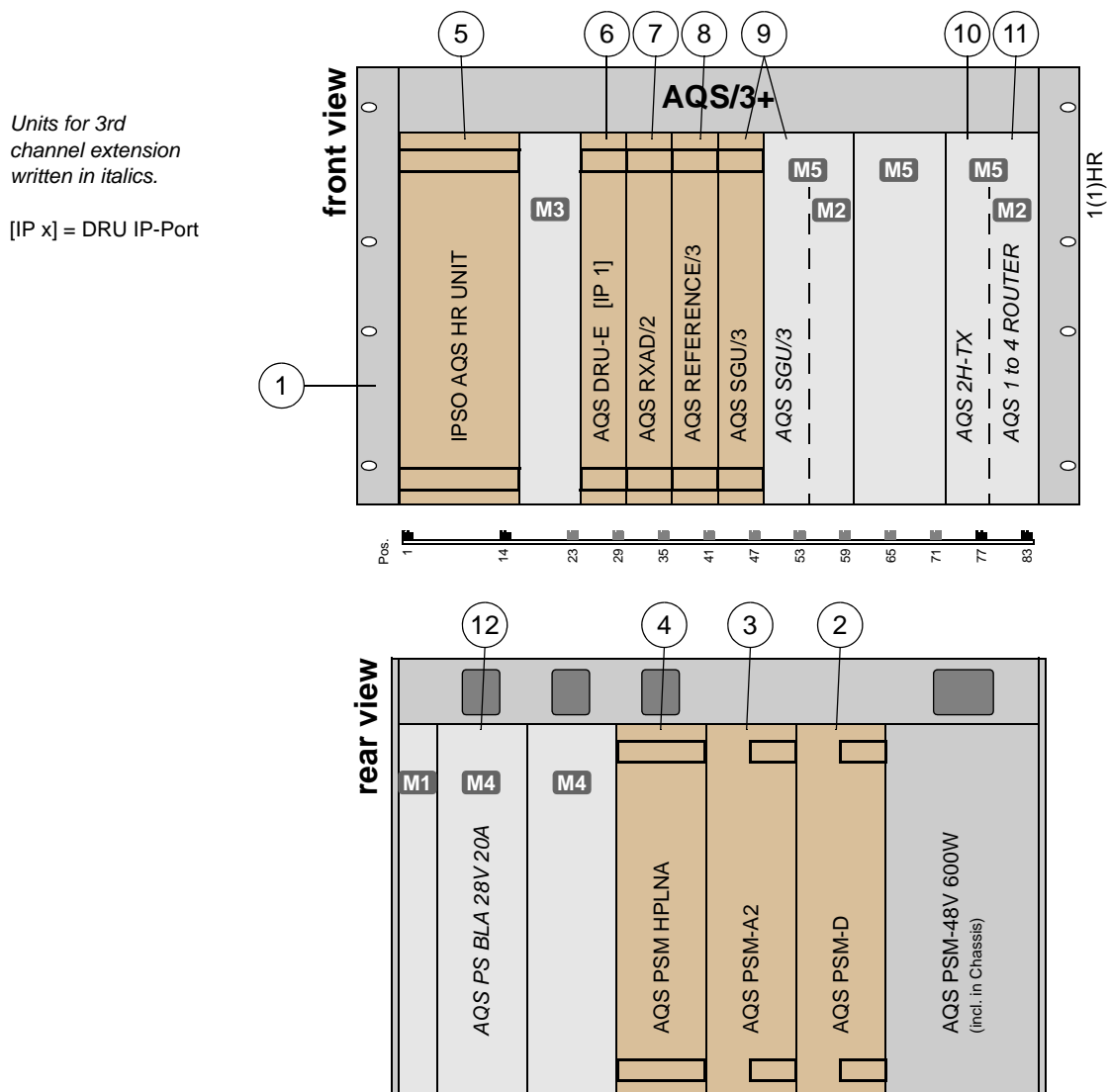

Figure 6.2 AQS/3+ for 2 channel AVANCE III HD (internal IP SO)

## 6.2 A Typical 2 to 6 Channel AV III HD HR & Solids (ext. IPSO)

### 6.2.1 Bill of Material

Pos.	Units	Part Number	Description <i>Channel extension and options written in italics.</i>
1	1	Z120343	AQS/3+ CHASSIS WIRED
2	1	Z121625	AQS PSM-D POWER SUPPLY MODULE
3	1	Z133424	AQS PSM-A2 POWER SUPPLY MODULE
4	1 (2)	Z104783	AQS PSM HPLNA
5	1	Z102520	AQS DRU-E ECL $\geq$ 06
6	1	Z130588 Z130589	AQS RECEIVER BOARD RXAD/2 600 AQS RECEIVER BOARD RXAD/2 1000
7	1	Z116985 Z126572	AQS REFERENCE BOARD/3 600 AQS REFERENCE BOARD/3 1200
8	1 (3)	Z117129 Z117130	AQS SGU/3 600 AQS SGU/3 1200
9	1	Z103550 Z103551	AQS 2H-TX BD 200-400 AQS 2H-TX BD 500-1000
10	1	Z101247	AQS 1 TO 4 ROUTER
11	1	W1345050	AQS POWER SUPPLY BLA 28V 20A
<b>Mechanical Parts</b>			Mech. parts are components of the assembled chassis. Application and quantity are dependent on options. Only spare parts must be ordered separately.
M1	1	Z2778	FRONTPLATE BLIND 4TE
M2	2	Z12489	FRONTPLATE BLIND 6TE
M3	2	Z12170	FRONTPLATE BLIND 12TE
M4	3	Z14119 Z14120	FRONTPLATE BLIND 1MM 12TE COVERPLATE 8TE
M5	1	Z105564 Z105565	FRONTPLATE 1MM 24TE COVERPLATE 24TE
—	22	25958	SCREW RRCH KR M2,5 x 12,3

Table 6.3 Bill of material

## 6.2.2 Rackcode Setting

Rack Nb.	Rackcode	SW2	SW1	Pulse Switch (DRU Device Webpage)	Power-Up Delay
1	<b>0x0A</b>	0	A	closed (default)	0

## 6.2.3 Board Location

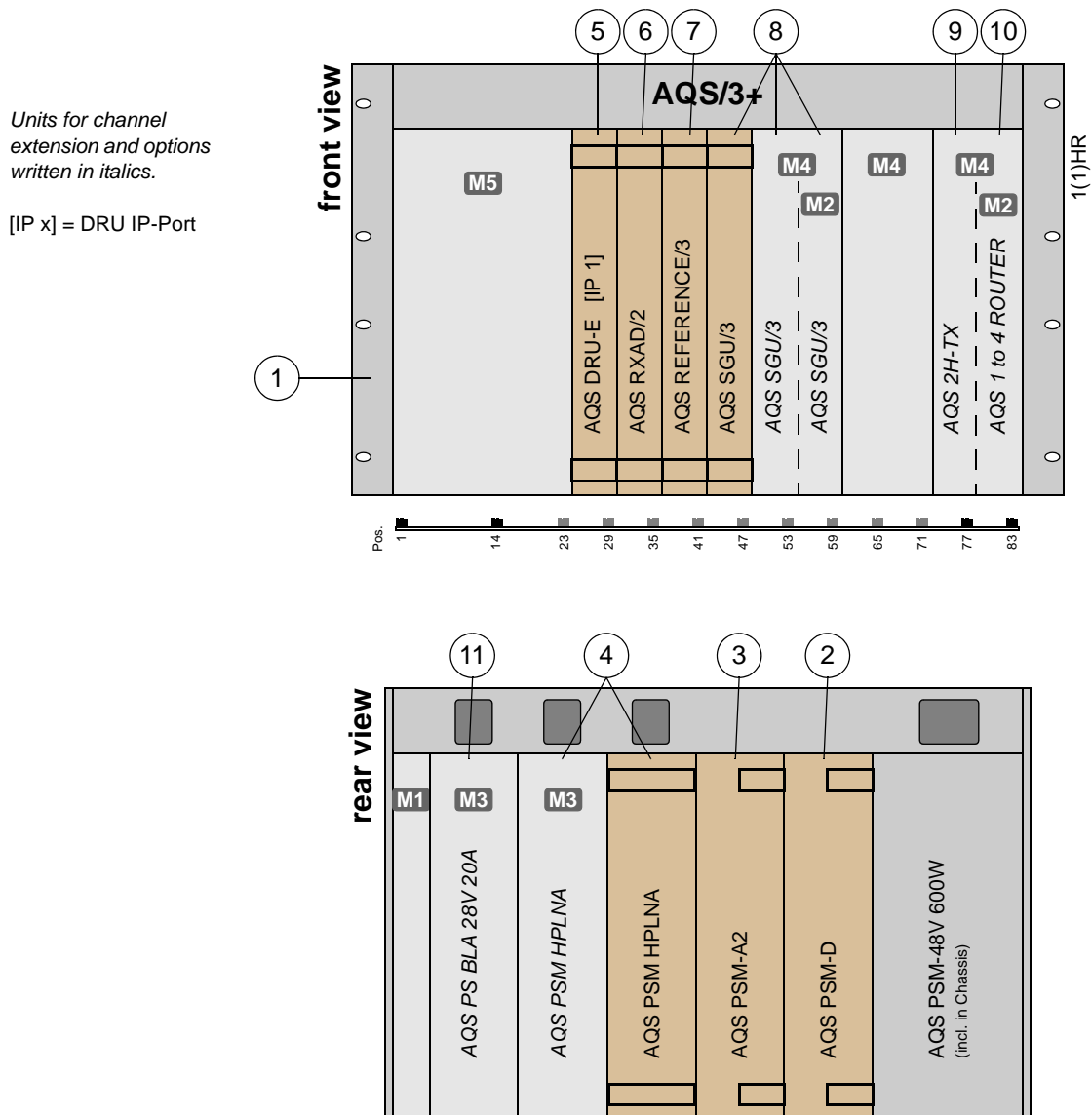

## 6.3 A Typical 2 Channel AV III HD HR Multi-RX (2 RX/TX)

### 6.3.1 Bill of Material

Pos.	Units	Part Number	Description <i>Channel extension and options written in italics.</i>
1	1	Z120343	AQS/3+ CHASSIS WIRED
2	1	Z121625	AQS PSM-D POWER SUPPLY MODULE
3	1	Z133424	AQS PSM-A2 POWER SUPPLY MODULE
4	1	Z104783	AQS PSM HPLNA
5	1	<i>H9984</i>	<i>IPSO AQS HR UNIT</i>
6	1	Z117129 Z117130	AQS SGU/3 600 AQS SGU/3 1200
7	2	Z1002520	AQS DRU-E ECL $\geq$ 06
8	2	Z130588 Z130589	AQS RECEIVER BOARD RXAD/2 600 AQS RECEIVER BOARD RXAD/2 1000
9	1	Z116985 Z126572	AQS REFERENCE BOARD/3 600 AQS REFERENCE BOARD/3 1200
10	2 1	20910 47040	HYBRID SPLITTER ZFSC-2-4 CN COAX ADAPT SMA-I M-M
11	1	Z103550 Z103551	<i>AQS 2H-TX BD 200-400</i> <i>AQS 2H-TX BD 500-1000</i>
12	1	Z101247	<i>AQS 1 TO 4 ROUTER</i>
13	1	W1345050	<i>AQS POWER SUPPLY BLA 28V 20A</i>
<b>Mechanical Parts</b>			Mech. parts are components of the assembled chassis. Application and quantity are dependent on options. Only spare parts must be ordered separately.
M1	1	Z2778	FRONTPLATE BLIND 4TE
M2	2	Z12489	FRONTPLATE BLIND 6TE
M3	3	Z12170	FRONTPLATE BLIND 12TE
M4	2	Z14119 Z14120	FRONTPLATE BLIND 1MM 12TE COVERPLATE 8TE
M5	1	Z13955 Z15202	FRONTPLATE 1MM 18TE COVERPLATE 16TE
M6	1	Z14133	FRONTPLATE BLIND 2TE
—	24	25958	SCREW RRCH KR M2,5 x 12,3

Table 6.4 Bill of material

## 6.3.2 Rackcode Setting

Rack Nb.	Rackcode	SW2	SW1	Pulse Switch (DRU Device Webpage)	Power-Up Delay
1	0x0A	0	A	opened	0

## 6.3.3 Board Location

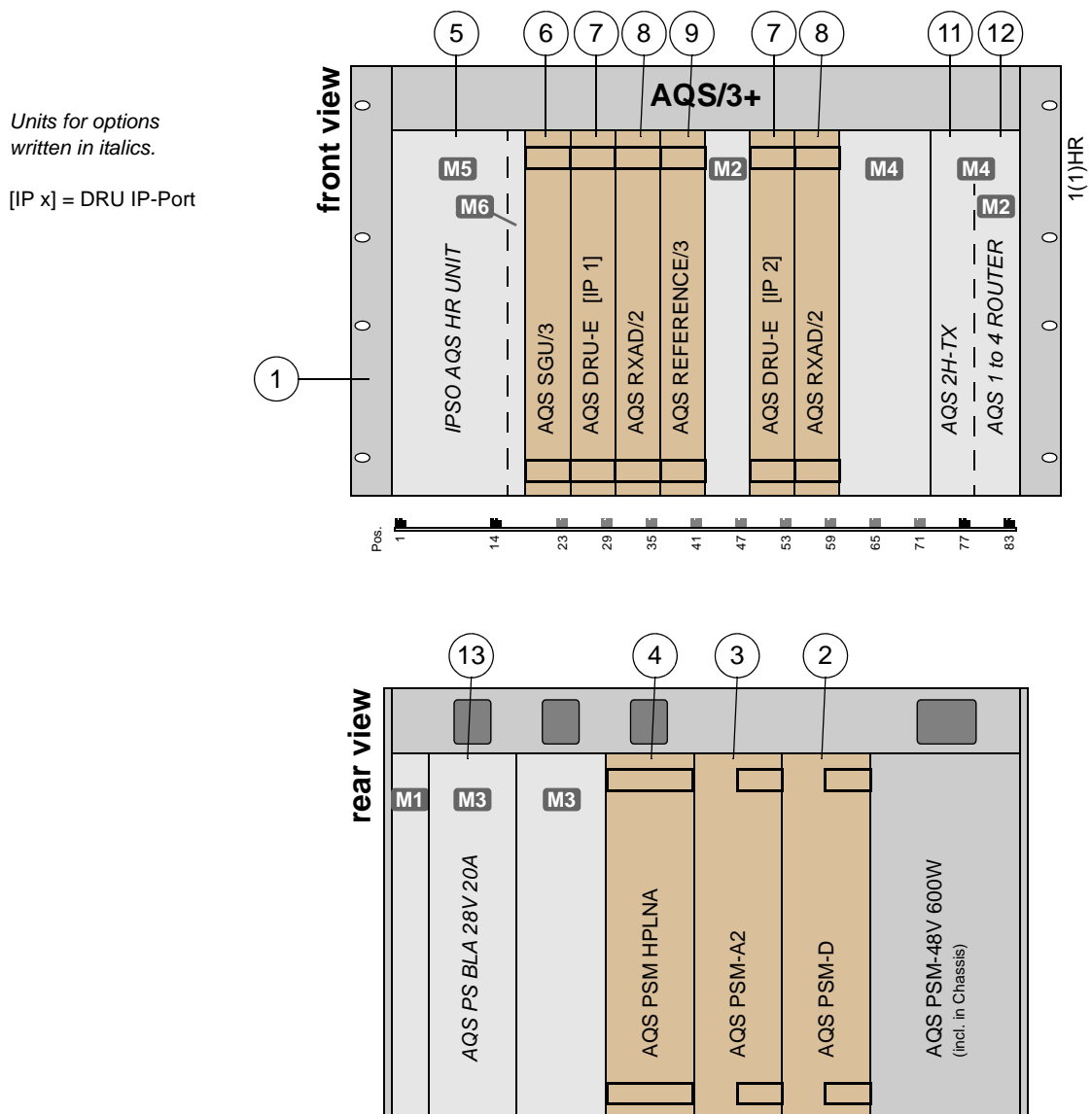

Figure 6.4 AQS/3+ for 2 RX/TX AVANCE III HD

## 6.3.4 LO2 Splitter and AUX Combiner

In a two-receiver system the LO2 signal from the reference board (J5) has to be split for the two receivers by use of a ZFSC-2-4 power splitter. The two outputs of the splitter are connected to the LO2\_IN input (J3) of each receiver.

In order to allow the two SGU/3 channel to generate the tune signal, the AUX outputs of CH1 (J2) and CH2 (J7) are combined with a second ZFSC-2-4. The combined output is connected to the TUNING\_IN connector of the HPPR cover module.

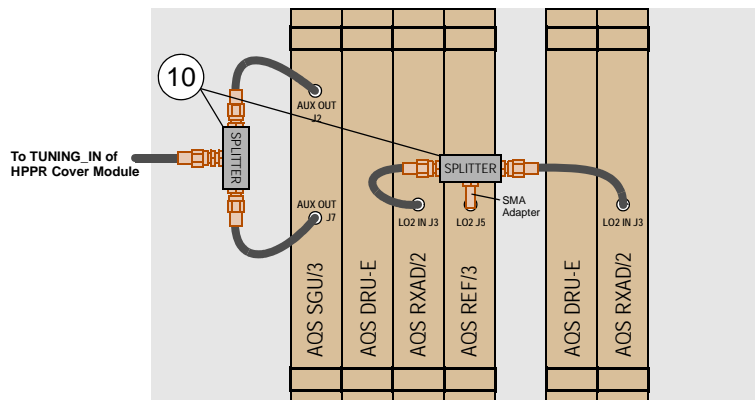

Figure 6.5 LO2 splitter and AUX combiner

## 6.4 A Typical 4 Channel AV III HD HR Multi-RX (2+2 RX/TX)

### 6.4.1 Bill of Material

Pos.	Units	Part Number	Description <i>Channel extension and options written in italics.</i>
1	1	Z120343	AQS/3+ CHASSIS WIRED
2	1	Z121625	AQS PSM-D POWER SUPPLY MODULE
3	1	Z133424	AQS PSM-A2 POWER SUPPLY MODULE
4	1	Z104783	AQS PSM HPLNA
5	1	Z117129 Z117130	AQS SGU/3 600 AQS SGU/3 1200
6	2	Z102520	AQS DRU-E ECL $\geq$ 06
7	2	Z130588 Z130589	AQS RECEIVER BOARD RXAD/2 600 AQS RECEIVER BOARD RXAD/2 1000
8	1	Z116985 Z126572	AQS REFERENCE BOARD/3 600 AQS REFERENCE BOARD/3 1200
9	1 1	20910 47040	HYBRID SPLITTER ZFSC-2-4 CN COAX ADAPT SMA-I M-M
10	1	Z103550 Z103551	AQS 2H-TX BD 200-400 AQS 2H-TX BD 500-1000
11	1	Z101247	AQS 1 TO 4 ROUTER
12	1	W1345050	AQS POWER SUPPLY BLA 28V 20A
<b>Mechanical Parts</b>			Mech. parts are components of the assembled chassis. Application and quantity are dependent on options. Only spare parts must be ordered separately.
M1	1	Z2778	FRONTPLATE BLIND 4TE
M2	2	Z12489	FRONTPLATE BLIND 6TE
M3	2	Z12170	FRONTPLATE BLIND 12TE
M4	2	Z14119 Z14120	FRONTPLATE BLIND 1MM 12TE COVERPLATE 8TE
M5	1	Z13955 Z15202	FRONTPLATE 1MM 18TE COVERPLATE 16TE
—	20	25958	SCREW RRCH KR M2,5 x 12,3

Table 6.5 Bill of material: rack 1

Pos.	Units	Part Number	Description <i>Channel extension and options written in italics.</i>
20	1	Z120343	AQS/3+ CHASSIS WIRED
21	1	Z121625	AQS PSM-D POWER SUPPLY MODULE
22	1	Z133424	AQS PSM-A2 POWER SUPPLY MODULE
23	1	Z104783	AQS PSM HPLNA
24	1	Z117129 Z117130	AQS SGU/3 600 AQS SGU/3 1200
25	2	Z102520	AQS DRU-E ECL ≥ 06
26	2	Z130588 Z130589	AQS RECEIVER BOARD RXAD/2 600 AQS RECEIVER BOARD RXAD/2 1000
27	1	Z129933	AQS LO2/CLK BOARD
<b>Mechanical Parts</b>			Mech. parts are components of the assembled chassis. Application and quantity are dependent on options. Only spare parts must be ordered separately.
M1	1	Z2778	FRONTPLATE BLIND 4TE
M2	1	Z12489	FRONTPLATE BLIND 6TE
M3	2	Z12170	FRONTPLATE BLIND 12TE
M4	2	Z14119 Z14120	FRONTPLATE BLIND 1MM 12TE COVERPLATE 8TE
M5	1	Z13955 Z15202	FRONTPLATE 1MM 18TE COVERPLATE 16TE
—	18	25958	SCREW RRCH KR M2,5 x 12,3

Table 6.6 Bill of material: rack 2

## 6.4.2 Rackcode Setting

Rack Nb.	Rackcode	SW2	SW1	Pulse Switch (DRU Device Webpage)	Power-Up Delay
1	0x0A	0	A	opened	0
2	0x1A	1	A	opened	1



## 6.4.3 Board Location

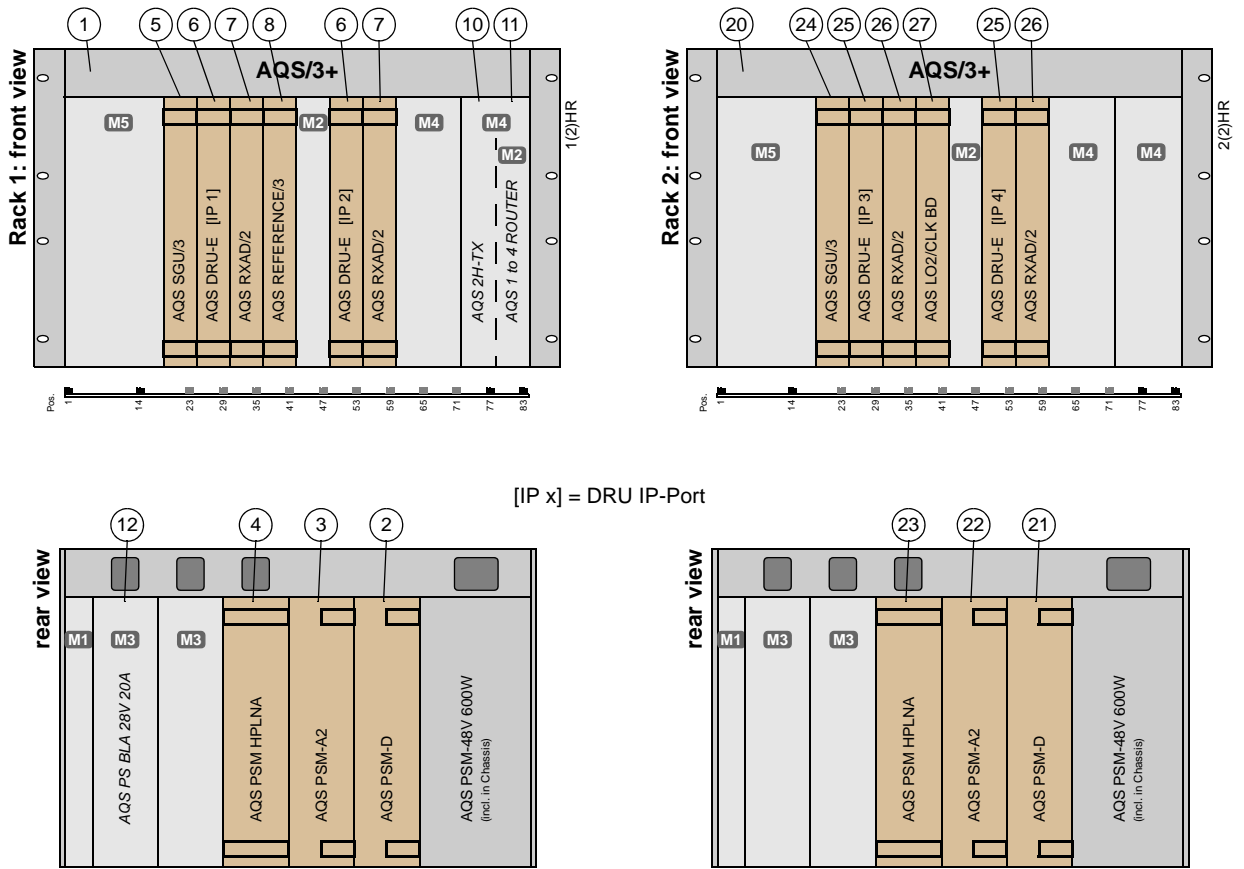

Figure 6.6 AQS/3+ for 2+2 RX/TX AVANCE III HD

## 6.4.4 20 MHz, REF and LO2 Distribution

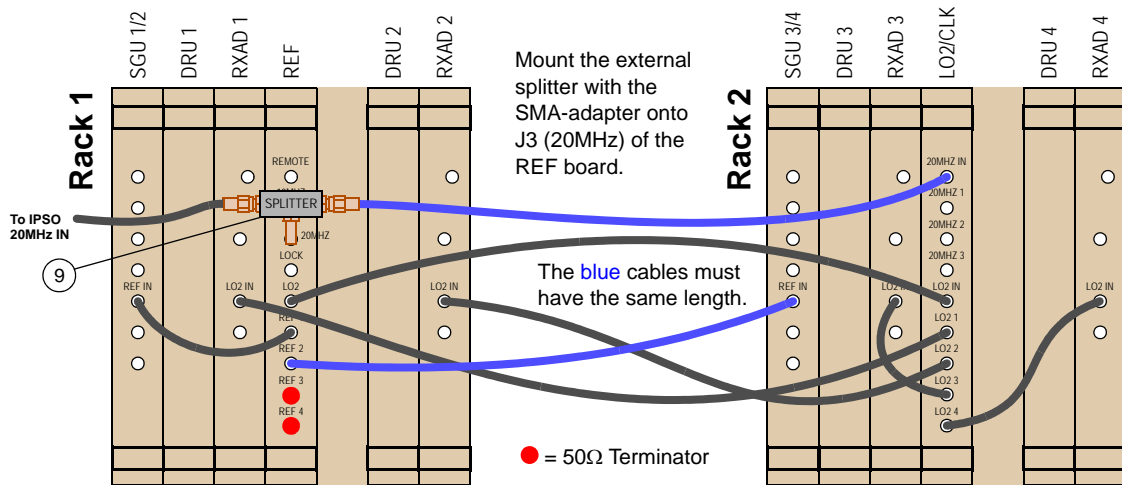

Figure 6.7 20 MHz, LO2 and REF distribution

## 6.5 A Typical 6 Channel AV III HD HR Multi-RX (2+2+2 RX/TX)

### 6.5.1 Bill of Material

Pos.	Units	Part Number	Description <i>Channel extension and options written in italics.</i>
1	1	Z120343	AQS/3+ CHASSIS WIRED
2	1	Z121625	AQS PSM-D POWER SUPPLY MODULE
3	1	Z133424	AQS PSM-A2 POWER SUPPLY MODULE
4	1	Z104783	AQS PSM HPLNA
5	1	Z117129 Z117130	AQS SGU/3 600 AQS SGU/3 1200
6	2	Z102520	AQS DRU-E ECL $\geq$ 06
7	2	Z130588 Z130589	AQS RECEIVER BOARD RXAD/2 600 AQS RECEIVER BOARD RXAD/2 1000
8	1	Z116985 Z126572	AQS REFERENCE BOARD/3 600 AQS REFERENCE BOARD/3 1200
9	1	Z129933	AQS LO2/CLK BOARD
10	1 1	20910 47040	HYBRID SPLITTER ZFSC-2-4 CN COAX ADAPT SMA-I M-M
11	1	Z103550 Z103551	AQS 2H-TX BD 200-400 AQS 2H-TX BD 500-1000
12	1	Z101247	AQS 1 TO 4 ROUTER
13	1	W1345050	AQS POWER SUPPLY BLA 28V 20A
<b>Mechanical Parts</b>			Mech. parts are components of the assembled chassis. Application and quantity are dependent on options. Only spare parts must be ordered separately.
M1	1	Z2778	FRONTPLATE BLIND 4TE
M2	1	Z12489	FRONTPLATE BLIND 6TE
M3	2	Z12170	FRONTPLATE BLIND 12TE
M4	2	Z14119 Z14120	FRONTPLATE BLIND 1MM 12TE COVERPLATE 8TE
M5	1	Z13955 Z15202	FRONTPLATE 1MM 18TE COVERPLATE 16TE
—	18	25958	SCREW RRCH KR M2,5 x 12,3

Table 6.7 Bill of material: rack 1

Pos.	Units	Part Number	Description <i>Channel extension and options written in italics.</i>
20	1	Z120343	AQS/3+ CHASSIS WIRED
21	1	Z121625	AQS PSM-D POWER SUPPLY MODULE
22	1	Z133424	AQS PSM-A2 POWER SUPPLY MODULE
23	1	Z104783	AQS PSM HPLNA
24	1	Z117129 Z117130	AQS SGU/3 600 AQS SGU/3 1200
25	2	Z102520	AQS DRU-E ECL ≥ 06
26	2	Z130588 Z130589	AQS RECEIVER BOARD RXAD/2 600 AQS RECEIVER BOARD RXAD/2 1000
27	1	Z129933	AQS LO2/CLK BOARD
<b>Mechanical Parts</b>			Mech. parts are components of the assembled chassis. Application and quantity are dependent on options. Only spare parts must be ordered separately.
M1	1	Z2778	FRONTPLATE BLIND 4TE
M2	1	Z12489	FRONTPLATE BLIND 6TE
M3	2	Z12170	FRONTPLATE BLIND 12TE
M4	2	Z14119 Z14120	FRONTPLATE BLIND 1MM 12TE COVERPLATE 8TE
M5	1	Z13955 Z15202	FRONTPLATE 1MM 18TE COVERPLATE 16TE
—	18	25958	SCREW RRCH KR M2,5 x 12,3

Table 6.8 Bill of material: rack 2

Pos.	Units	Part Number	Description <i>Channel extension and options written in italics.</i>
30	1	Z120343	AQS/3+ CHASSIS WIRED
31	1	Z121625	AQS PSM-D POWER SUPPLY MODULE
32	1	Z133424	AQS PSM-A2 POWER SUPPLY MODULE
33	1	Z104783	AQS PSM HPLNA
34	1	Z117129 Z117130	AQS SGU/3 600 AQS SGU/3 1200
35	2	Z102520	AQS DRU-E ECL $\geq$ 06
36	2	Z130588 Z130589	AQS RECEIVER BOARD RXAD/2 600 AQS RECEIVER BOARD RXAD/2 1000
37	1	Z129933	AQS LO2/CLK BOARD
<b>Mechanical Parts</b>			Mech. parts are components of the assembled chassis. Application and quantity are dependent on options. Only spare parts must be ordered separately.
M1	1	Z2778	FRONTPLATE BLIND 4TE
M2	1	Z12489	FRONTPLATE BLIND 6TE
M3	2	Z12170	FRONTPLATE BLIND 12TE
M4	2	Z14119 Z14120	FRONTPLATE BLIND 1MM 12TE COVERPLATE 8TE
M5	1	Z13955 Z15202	FRONTPLATE 1MM 18TE COVERPLATE 16TE
—	18	25958	SCREW RRCH KR M2,5 x 12,3

Table 6.9 Bill of material: rack 3

## 6.5.2 Rackcode Setting

Rack Nb.	Rackcode	SW2	SW1	Pulse Switch (DRU Device Webpage)	Power-Up Delay
1	<b>0x0A</b>	0	A	opened	0
2	<b>0x1A</b>	1	A	opened	1
3	<b>0x2A</b>	2	A	opened	2

## 6.5.3 Board Location

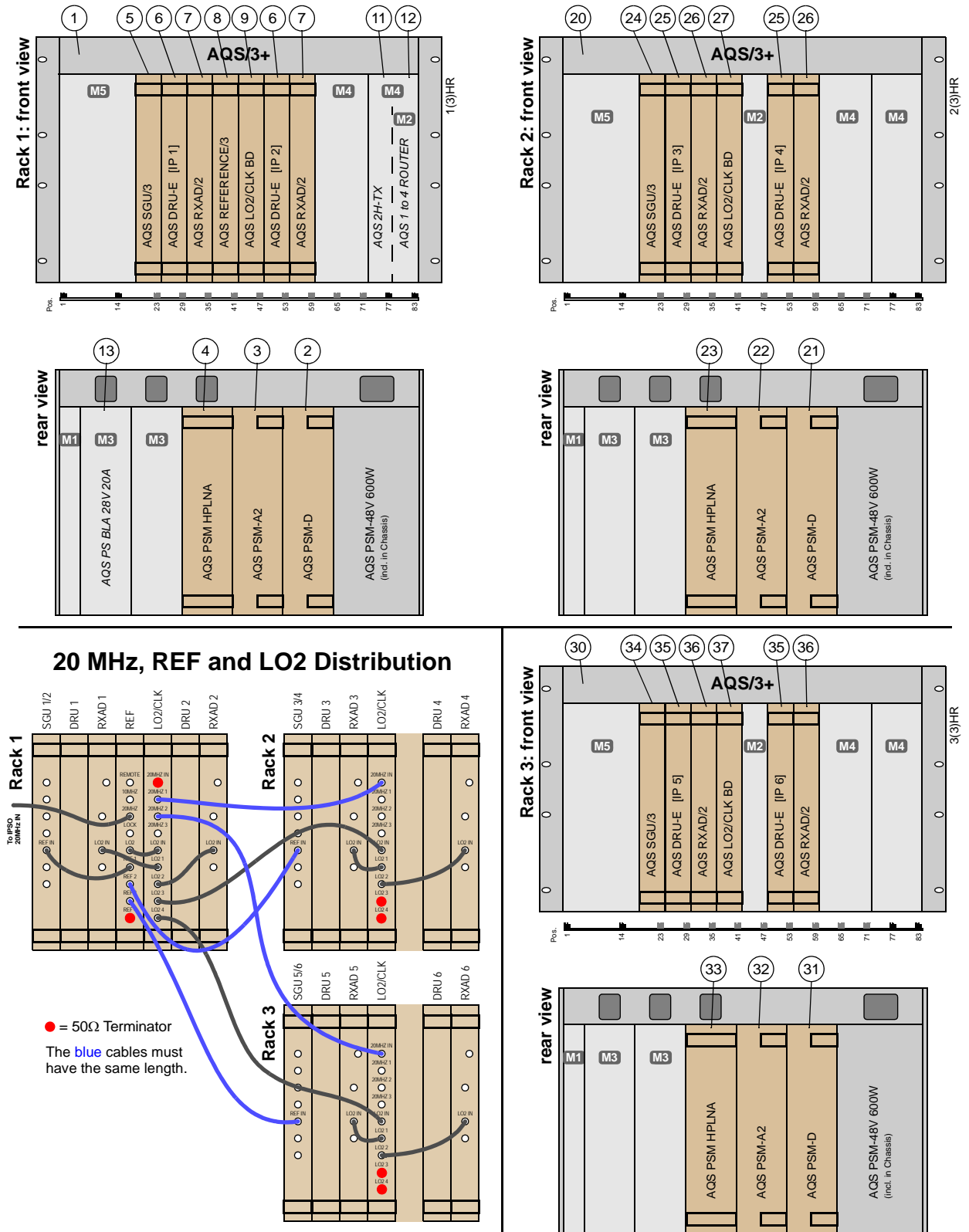

Figure 6.8 AQS/3+ for 2+2+2 RX/TX AVANCE III HD

## 6.6 A Typical 1 Channel AV III HD PharmaScan with 1 RX

### 6.6.1 Bill of Material

Pos.	Units	Part Number	Description <i>Channel extension and options written in italics.</i>
1	1	Z120343	AQS/3+ CHASSIS WIRED
2	1	Z121625	AQS PSM-D POWER SUPPLY MODULE
3	1	Z133424	AQS PSM-A2 POWER SUPPLY MODULE
4	1	Z102520	AQS DRU-E ECL $\geq$ 06
5	1	Z130588	AQS RECEIVER BOARD RXAD/2 600
6	1	Z116985	AQS REFERENCE BOARD/3 600
7	1	Z117129	AQS SGU/3 600
<b>Mechanical Parts</b>			Mech. parts are components of the assembled chassis. Application and quantity are dependent on options. Only spare parts must be ordered separately.
M1	1	Z2778	FRONTPLATE BLIND 4TE
M2	3	Z12170	FRONTPLATE BLIND 12TE
M3	3	Z14119 Z14120	FRONTPLATE BLIND 1MM 12TE COVERPLATE 8TE
M4	1	Z105564 Z105565	FRONTPLATE 1MM 24TE COVERPLATE 24TE
—	22	25958	SCREW RRCH KR M2,5 x 12,3

Table 6.10 Bill of material

## 6.6.2 Rackcode Setting

Rack Nb.	Rackcode	SW2	SW1	Pulse Switch (DRU Device Webpage)	Power-Up Delay
1	0x0A	0	A	closed (default)	0

## 6.6.3 Board Location

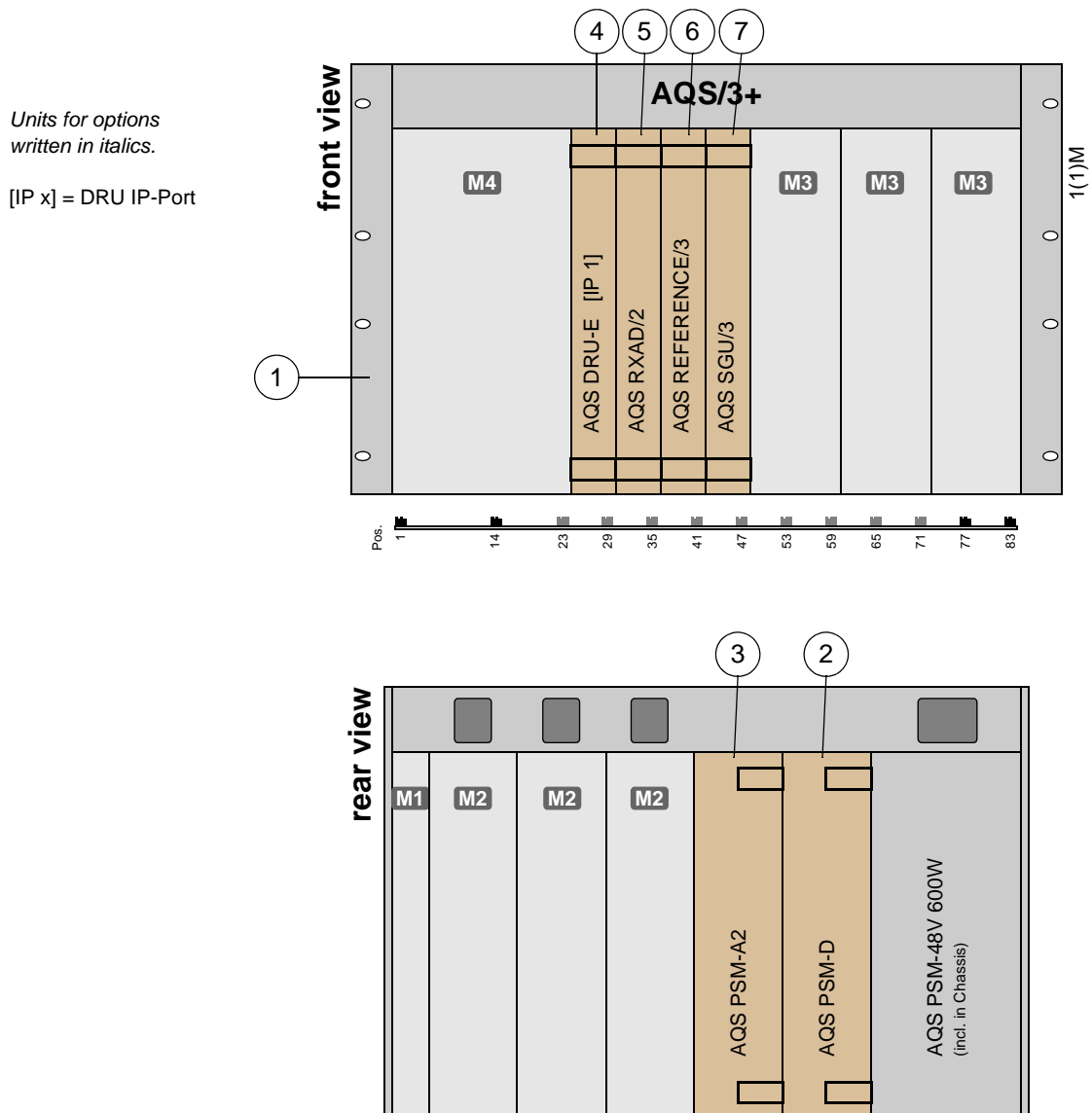

Figure 6.9 AQS/3+ for 1 channel (RX/TX) PharmaScan AVANCE III HD

## 6.7 A Typical 2 Channel AV III HD BioSpec (2-4 TX / 1 RX)

### 6.7.1 Bill of Material

Pos.	Units	Part Number	Description <i>Channel extension and options written in italics.</i>
1	1	Z120343	AQS/3+ CHASSIS WIRED
2	1	Z121625	AQS PSM-D POWER SUPPLY MODULE
3	1	Z133424	AQS PSM-A2 POWER SUPPLY MODULE
4	2	<i>Z104783</i>	<i>AQS PSM HPLNA</i>
5	1	<i>Z107413</i>	<i>AQS PSM ADM</i>
6	1	Z102520	AQS DRU-E ECL $\geq$ 06
7	1	Z130588 Z130589	AQS RECEIVER BOARD RXAD/2 600 AQS RECEIVER BOARD RXAD/2 1000
8	1	Z116985 Z126572	AQS REFERENCE BOARD/3 600 AQS REFERENCE BOARD/3 1200
9	1 (2)	Z117129 Z117130	AQS SGU/3 600 AQS SGU/3 1200
<b>Mechanical Parts</b>			Mech. parts are components of the assembled chassis. Application and quantity are dependent on options. Only spare parts must be ordered separately.
M1	1	Z2778	FRONTPLATE BLIND 4TE
M2	1	Z12489	FRONTPLATE BLIND 6TE
M3	3	Z12170	FRONTPLATE BLIND 12TE
M4	3	Z14119 Z14120	FRONTPLATE BLIND 1MM 12TE COVERPLATE 8TE
M5	1	Z105564 Z105565	FRONTPLATE 1MM 24TE COVERPLATE 24TE
—	24	25958	SCREW RRCH KR M2,5 x 12,3

Table 6.11 Bill of material



## 6.7.2 Rackcode Setting

Rack Nb.	Rackcode	SW2	SW1	Pulse Switch (DRU Device Webpage)	Power-Up Delay
1	0x0A	0	A	closed (default)	0

## 6.7.3 Board Location

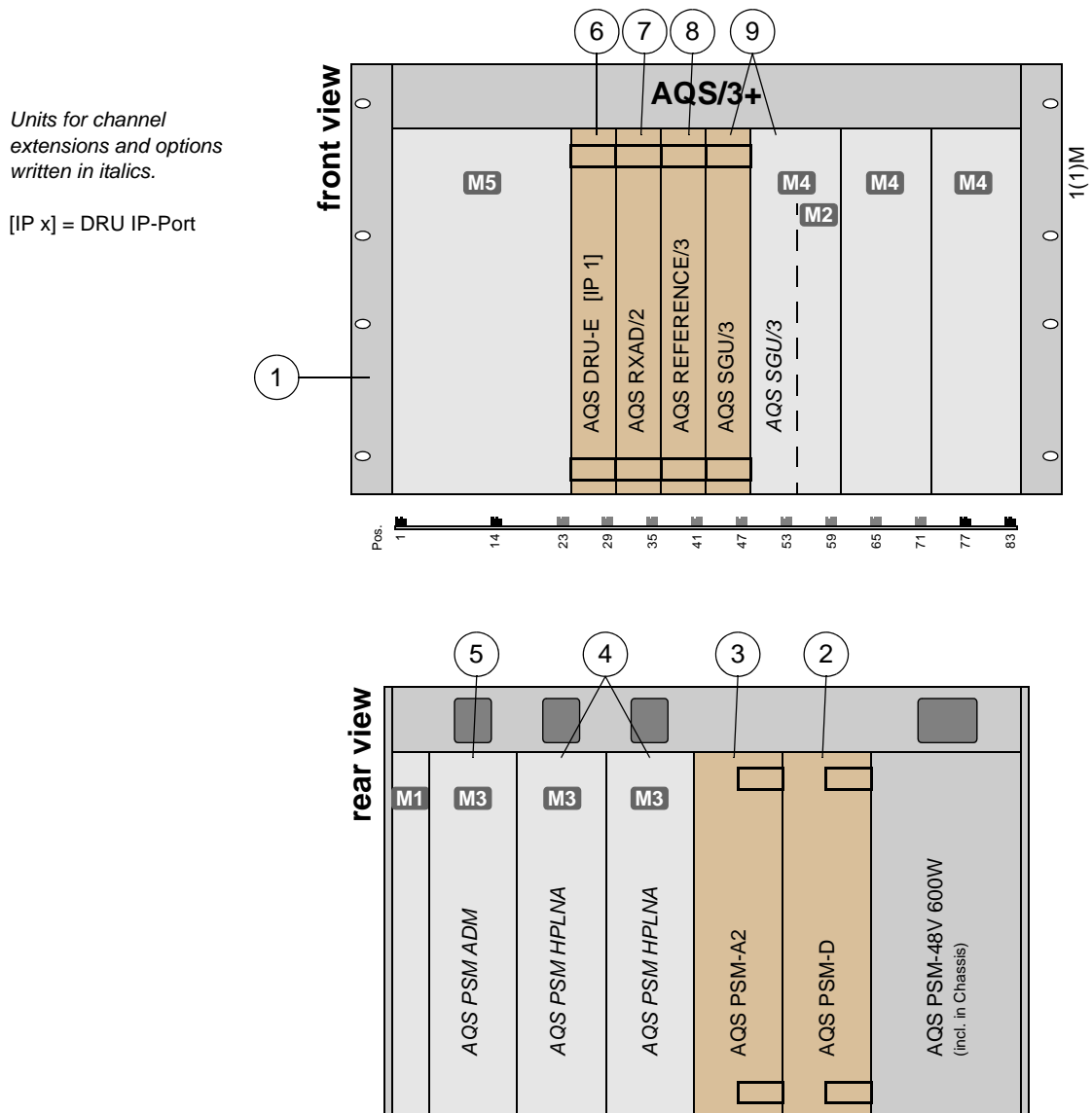

Figure 6.10 AQS/3+ for 2 channel (2-4TX/1RX) BioSpec AVANCE III HD

## 6.8 A Typical 2 Channel AV III HD BioSpec with mRX Option (2 TX / 4,8,16 RX)

### 6.8.1 Bill of Material

Pos.	Units	Part Number	Description <i>Channel extension and options written in italics.</i>
1	1	Z120343	AQS/3+ CHASSIS WIRED
2	1	Z121625	AQS PSM-D POWER SUPPLY MODULE
3	1	Z133424	AQS PSM-A2 POWER SUPPLY MODULE
4	2	<i>Z104783</i>	<i>AQS PSM HPLNA</i>
5	1	<i>Z107413</i>	<i>AQS PSM ADM</i>
6	2	Z102520	AQS DRU-E ECL $\geq$ 06
7	2	Z130588 Z130589	AQS RECEIVER BOARD RXAD/2 600 AQS RECEIVER BOARD RXAD/2 1000
8	1	Z116985 Z126572	AQS REFERENCE BOARD/3 600 AQS REFERENCE BOARD/3 1200
9	1	Z117129 Z117130	AQS SGU/3 600 AQS SGU/3 1200
10	1	Z104431	AQS PULSE SPLITTER
<b>Mechanical Parts</b>			Mech. parts are components of the assembled chassis. Application and quantity are dependent on options. Only spare parts must be ordered separately.
M1	1	Z2778	FRONTPLATE BLIND 4TE
M2	2	Z12489	FRONTPLATE BLIND 6TE
M3	3	Z12170	FRONTPLATE BLIND 12TE
M4	1	Z14119 Z14120	FRONTPLATE BLIND 1MM 12TE COVERPLATE 8TE
M5	1	Z13955 Z15202	FRONTPLATE 1MM 18TE COVERPLATE 16TE
—	22	25958	SCREW RRCH KR M2,5 x 12,3

Table 6.12 Bill of material: rack 1

Pos.	Units	Part Number	Description <i>Channel extension and options written in italics.</i>
20	1	Z103493	AQS/2-M CHASSIS WIRED ECL ≥ 01
21	1	Z003402	AQS PSM1 POWER SUPPLY MODULE
22	1	Z102023	AQS PSM5 POWER SUPPLY MODULE
23	1	<i>Z104783</i>	<i>AQS PSM HPLNA</i>
24	1	Z104432	AQS RF-SPLITTER
25	1	H9489	AQS POWER SUPPLY DIGITAL 350W ECL ≥ 11
26	2 (7)	Z102520	AQS DRU-E ECL ≥ 02
27	2 (7)	Z130588 Z130589	AQS RECEIVER BOARD RXAD/2 600 AQS RECEIVER BOARD RXAD/2 1000
<b>Mechanical Parts</b>			Mech. parts are components of the assembled chassis. Application and quantity are dependent on options. Only spare parts must be ordered separately.
M1	1	Z2778	FRONTPLATE BLIND 4TE
M3	1	Z12170	FRONTPLATE BLIND 12TE
M4	5	Z14119 Z14120	FRONTPLATE 1MM 12TE COVERPLATE 8TE
—	16	25958	SCREW RRCH KR M2,5 x 12,3

Table 6.13 Bill of material: rack 2

Pos.	Units	Part Number	Description <i>Channel extension and options written in italics.</i>
30	1	Z103493	AQS/2-M CHASSIS WIRED ECL ≥ 01
31	1	Z003402	AQS PSM1 POWER SUPPLY MODULE
32	1	Z102023	AQS PSM5 POWER SUPPLY MODULE
33	1	<i>Z104783</i>	<i>AQS PSM HPLNA</i>
34	1	Z104432	AQS RF-SPLITTER
35	1	H9489	AQS POWER SUPPLY DIGITAL 350W ECL ≥ 11
36	7	Z102520	AQS DRU-E ECL ≥ 06
37	7	Z130588 Z130589	AQS RECEIVER BOARD RXAD/2 600 AQS RECEIVER BOARD RXAD/2 1000
<b>Mechanical Parts</b>			Mech. parts are components of the assembled chassis. Application and quantity are dependent on options. Only spare parts must be ordered separately.
M1	1	Z2778	FRONTPLATE BLIND 4TE
M3	1	Z12170	FRONTPLATE BLIND 12TE
—	6	25958	SCREW RRCH KR M2,5 x 12,3

Table 6.14 Bill of material: rack 3 (for 16 RX option only)

## 6.8.2 Rackcode Setting

Rack Nb.	Rack Code	Userbus			Pulse Switch (DRU Device Webpage)			Power-Up Delay
		SW3	SW2	SW1	1	2	3	
1	0x0A	-	0	A	opened		-	0
2	0x102	1	0	2	closed			1
3	0x202	2	0	2	closed			2

## 6.8.3 Board Location

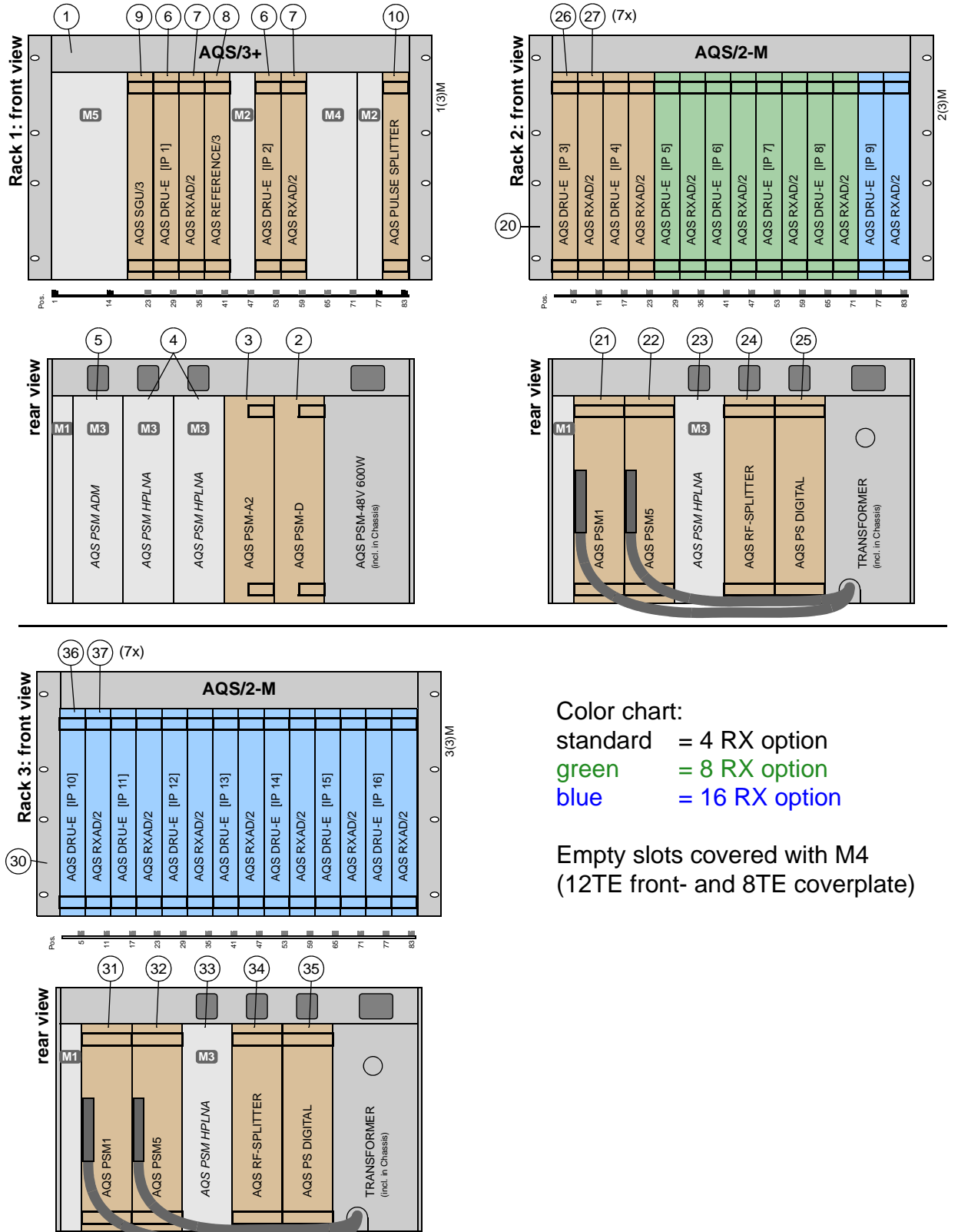

Figure 6.11 AQS/3+ for 2 channel BioSpec with mRX Option (2 TX / 4,8,16 RX)

## 6.9 A Typical 2 Channel AV III HD BioSpec with pTX Option (8 TX / 2 RX)

### 6.9.1 Bill of Material

Pos.	Units	Part Number	Description <i>Channel extension and options written in italics.</i>
1	1	Z120343	AQS/3+ CHASSIS WIRED
2	1	Z121625	AQS PSM-D POWER SUPPLY MODULE
3	1	Z133424	AQS PSM-A2 POWER SUPPLY MODULE
4	2	<i>Z104783</i>	<i>AQS PSM HPLNA</i>
5	1	<i>Z107413</i>	<i>AQS PSM ADM</i>
6	2	Z102520	AQS DRU-E ECL $\geq$ 06
7	2	Z130588 Z130589	AQS RECEIVER BOARD RXAD/2 600 AQS RECEIVER BOARD RXAD/2 1000
8	1	Z126573	AQS REFERENCE BOARD/3-M 1200
9	2	Z117129 Z117130	AQS SGU/3 600 AQS SGU/3 1200
10	1	Z104431	AQS PULSE SPLITTER
11	1 1	20910 47040	HYBRID SPLITTER ZFSC-2-4 CN COAX ADAPT SMA-I M-M
12	2	45999	ATTENUATOR SMA-SMA 6DB
<b>Mechanical Parts</b>			Mech. parts are components of the assembled chassis. Application and quantity are dependent on options. Only spare parts must be ordered separately.
M1	1	Z2778	FRONTPLATE BLIND 4TE
M2	1	Z12489	FRONTPLATE BLIND 6TE
M3	3	Z12170	FRONTPLATE BLIND 12TE
M4	1	Z14119 Z14120	FRONTPLATE BLIND 1MM 12TE COVERPLATE 8TE
M5	1	Z13955 Z15202	FRONTPLATE 1MM 18TE COVERPLATE 16TE
—	20	25958	SCREW RRCH KR M2,5 x 12,3

Table 6.15 Bill of material: rack 1

Pos.	Units	Part Number	Description <i>Channel extension and options written in italics.</i>
20	1	Z120343	AQS/3+ CHASSIS WIRED
21	1	Z121625	AQS PSM-D POWER SUPPLY MODULE
22	1	Z133424	AQS PSM-A2 POWER SUPPLY MODULE
23	3	<i>Z104783</i>	<i>AQS PSM HPLNA</i>
24	1	Z102520	AQS DRU-E ECL ≥ 06
25	1	Z129933	AQS LO2/CLK BOARD
26	3	Z117129 Z117130	AQS SGU/3 600 AQS SGU/3 1200
27	2	Z102000	AQS BB SPLITTER 2-WAY
<b>Mechanical Parts</b>			Mech. parts are components of the assembled chassis. Application and quantity are dependent on options. Only spare parts must be ordered separately.
M1	1	Z2778	FRONTPLATE BLIND 4TE
M2	1	Z12489	FRONTPLATE BLIND 6TE
M3	3	Z12170	FRONTPLATE BLIND 12TE
M4	2	Z14119 Z14120	FRONTPLATE 1MM 12TE COVERPLATE 8TE
M5	1	Z105564 Z105565	FRONTPLATE 1MM 24TE COVERPLATE 24TE
—	22	25958	SCREW RRCH KR M2,5 x 12,3

Table 6.16 Bill of material: rack 2

## 6.9.2 Rackcode Setting

Rack Nb.	Rackcode	SW2	SW1	Pulse Switch (DRU Device Webpage)	Power-Up Delay
1	<b>0x0A</b>	0	A	opened	0
(16)	<b>0xFA</b>	F	A	closed (default)	1

**i** The pTX rack is the last chassis in the configuration. It is always set to rack number 16 = 0xF regardless of how many receiver racks are used to avoid DRU IP-port number conflicts. However the power-up delay has to be set according to the real rack number, which is the total number of racks -1.

Example: pTX is rack number 3: rackcode = **0xFA**, power-up delay = **2**

## 6.9.3 Board Location

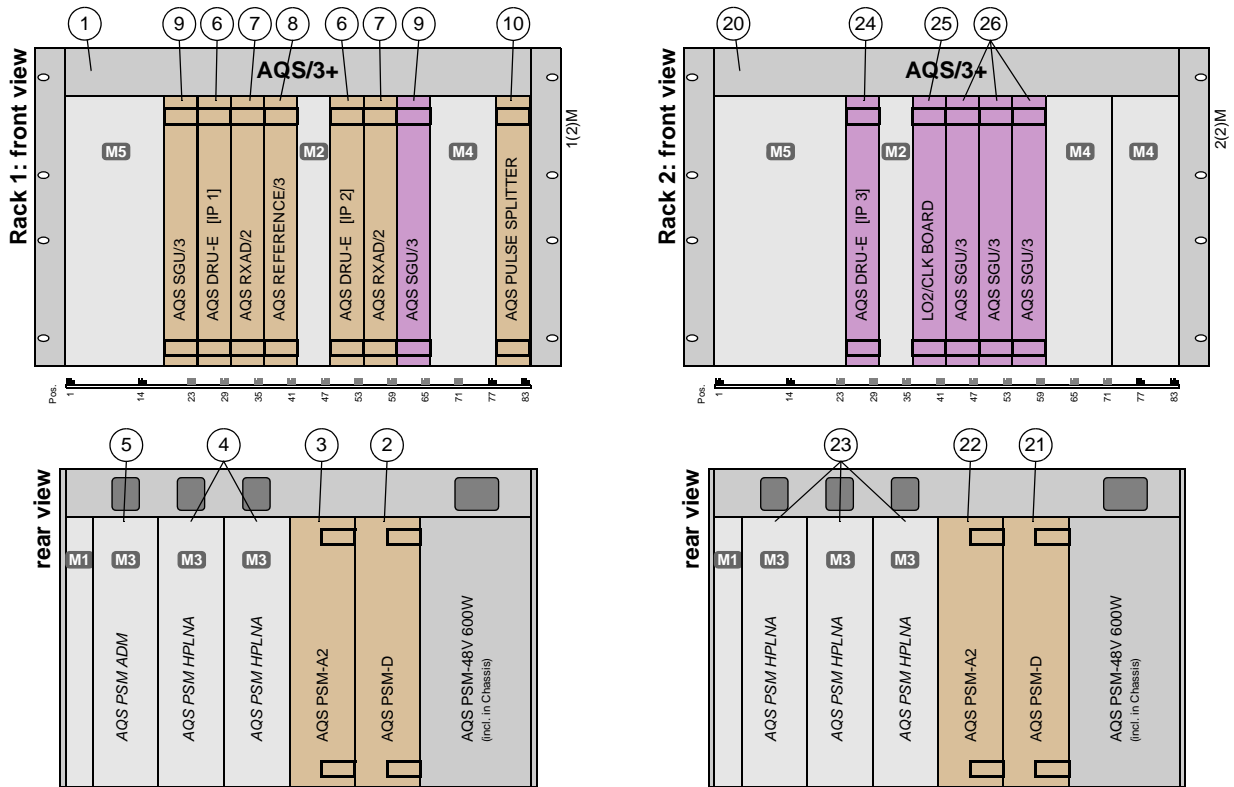

violet = 8pTX option

Figure 6.12 AQS/3+ for 2 channel BioSpec with pTX Option (2+8TX/2RX)

## 6.9.4 20 MHz, LO2 and REF Distribution

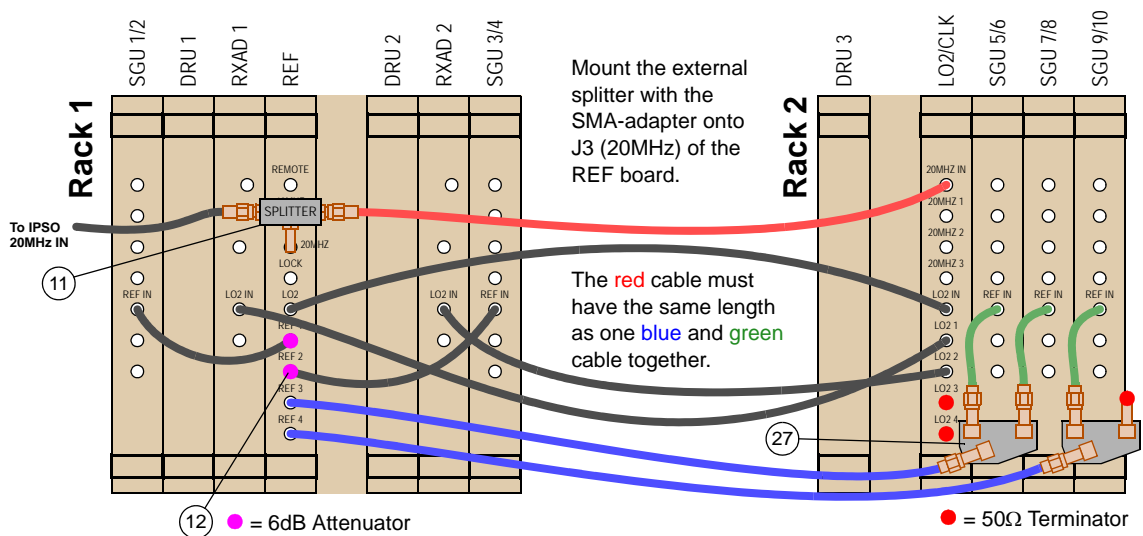

Figure 6.13 20 MHz, LO2 and REF distribution



## 6.9.5 Upgrade with mRX Options (4/8/16 RX)

---

This configuration is upgradable with additional RX channels to 4, 8 or 16RX.

### Bill of Material:

Add AQS/2-M Chassis with DRU and RXAD boards according to [Table 6.13](#) (rack 2) and [Table 6.14](#) (rack 3).

### Rackcode Setting:

The pTX rack is the last chassis in the configuration. It is always set to rack number 16 to avoid DRU IP-port number conflicts, regardless how many receiver racks are used.

However the power-up delay has to be set according to the real rack number, which is the total number of racks -1.

Example: pTX is rack number 4: rackcode = **0xFA**, power-up delay = **3**

### Board Location:

Use the same board locations for rack 2 and rack 3 as in [Figure 6.11](#)

### 20 MHz, LO2 and REF Distribution:

The 20MHz and REF distribution remains the same as in [Figure 6.13](#). The LO and LO2's are distributed via the RF-splitter board in the AQS/2-M chassis.

## 6.10 A Typical 2 Channel AV III HD Dual RX Low and High Field

### 6.10.1 Bill of Material

Pos.	Units	Part Number	Description <i>Channel extension and options written in italics.</i>
1	1	Z120343	AQS/3+ CHASSIS WIRED
2	1	Z121625	AQS PSM-D POWER SUPPLY MODULE
3	1	Z133424	AQS PSM-A2 POWER SUPPLY MODULE
4	1	Z104783	AQS PSM HPLNA
5	2	Z102520	AQS DRU-E ECL $\geq 06$
6	1	Z102501	AQS RECEIVER BOARD RXAD FTMS
7	1	Z130588	AQS RECEIVER BOARD RXAD/2 600
8	1	Z116985	AQS REFERENCE BOARD/3 600
9	1	Z117131	AQS SGU/3 LF
10	1	Z117129	AQS SGU/3 600
<b>Mechanical Parts</b>			Mech. parts are components of the assembled chassis. Application and quantity are dependent on options. Only spare parts must be ordered separately.
M1	1	Z2778	FRONTPLATE BLIND 4TE
M2	1	Z12489	FRONTPLATE BLIND 6TE
M3	2	Z12170	FRONTPLATE BLIND 12TE
M4	1	Z14119 Z14120	FRONTPLATE BLIND 1MM 12TE COVERPLATE 8TE
M5	1	Z105564 Z105565	FRONTPLATE 1MM 24TE COVERPLATE 24TE
—	16	25958	SCREW RRCH KR M2,5 x 12,3

Table 6.17 Bill of material

## 6.10.2 Rackcode Setting

Rack Nb.	Rackcode	SW2	SW1	Pulse Switch (DRU Device Webpage)	Power-Up Delay
1	0x0A	0	A	opened	0

## 6.10.3 Board Location

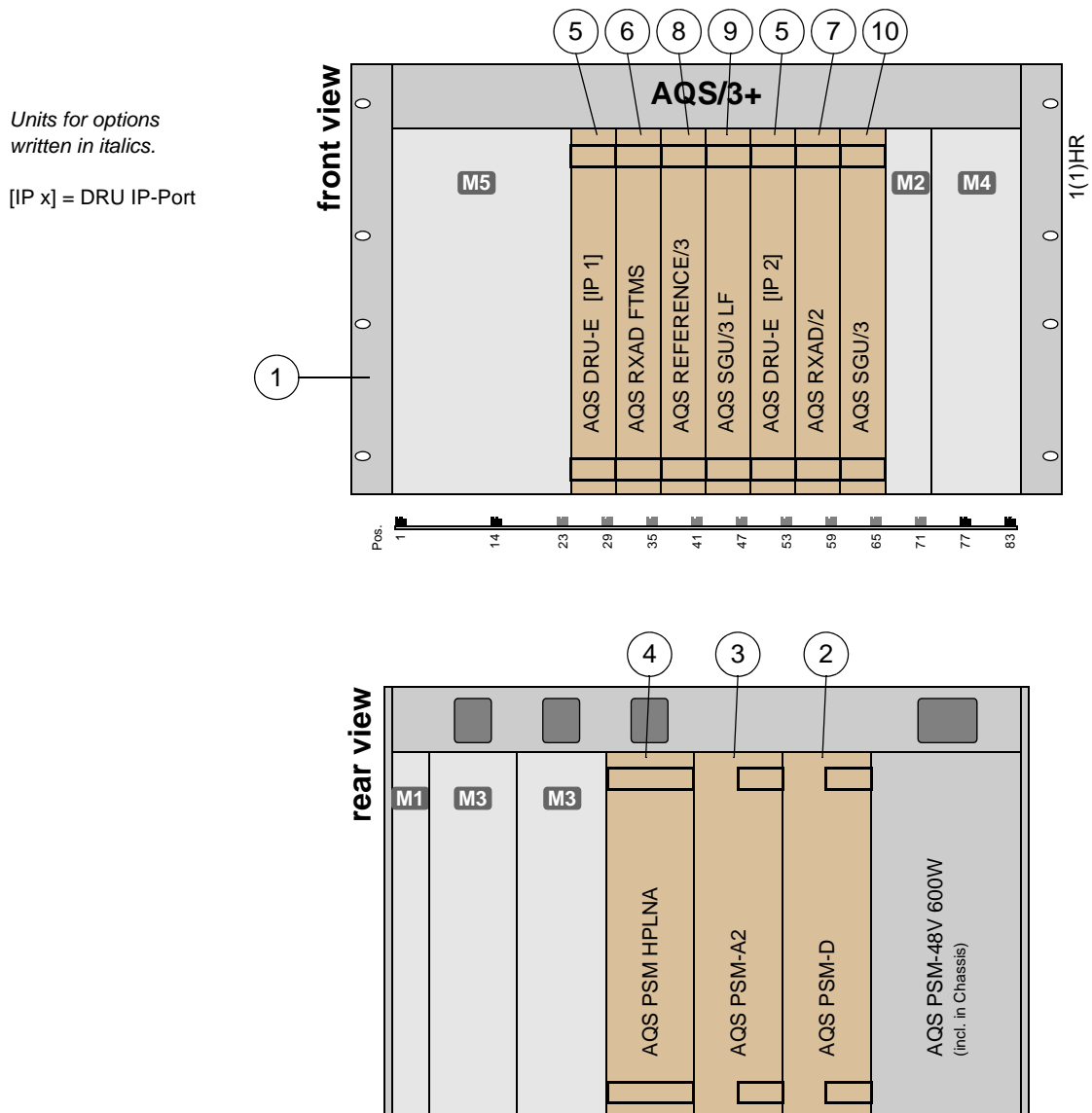

Figure 6.14 AQS/3+ for 2 channel Dual RX AVANCE III HD



# 7 AQS/3+ Mainframe

## 7.1 Introduction

---

The AQS/3+ mainframe consists of a single backplane, replacing the former AQS/3 IPSO and user bus parts. It can be equipped with an AQS IPSO and various AQS RF units (e.g. SGU/3, REFERENCE/3, RXAD/2, DRU, 1 to 4 Router, Pulse Splitter).

---

**i** The AQS/3+ mainframe is intended for the use with the double channel SGU/3 and the corresponding REFERENCE/3 board only. The former SGU/2 and REFERENCE boards are not supported.

---

On the rear side, one AC/DC power supply (PSM-48V) feeds two DC/DC power supply modules (PSM-A2 & PSM-D). Next to them are 3 slots for auxiliary power supply modules (PSM-HPLNA, PSM-ADM). Their mains supply are plugged into the line output connectors above their slot.

The mainframe is cooled with 8 fans located in a fan tray on top of the mainframe. The fan tray is serviceable without removing the mainframe from the spectrometer cabinet. (see "[Fans](#)" on page 78)

## 7.2 Front View

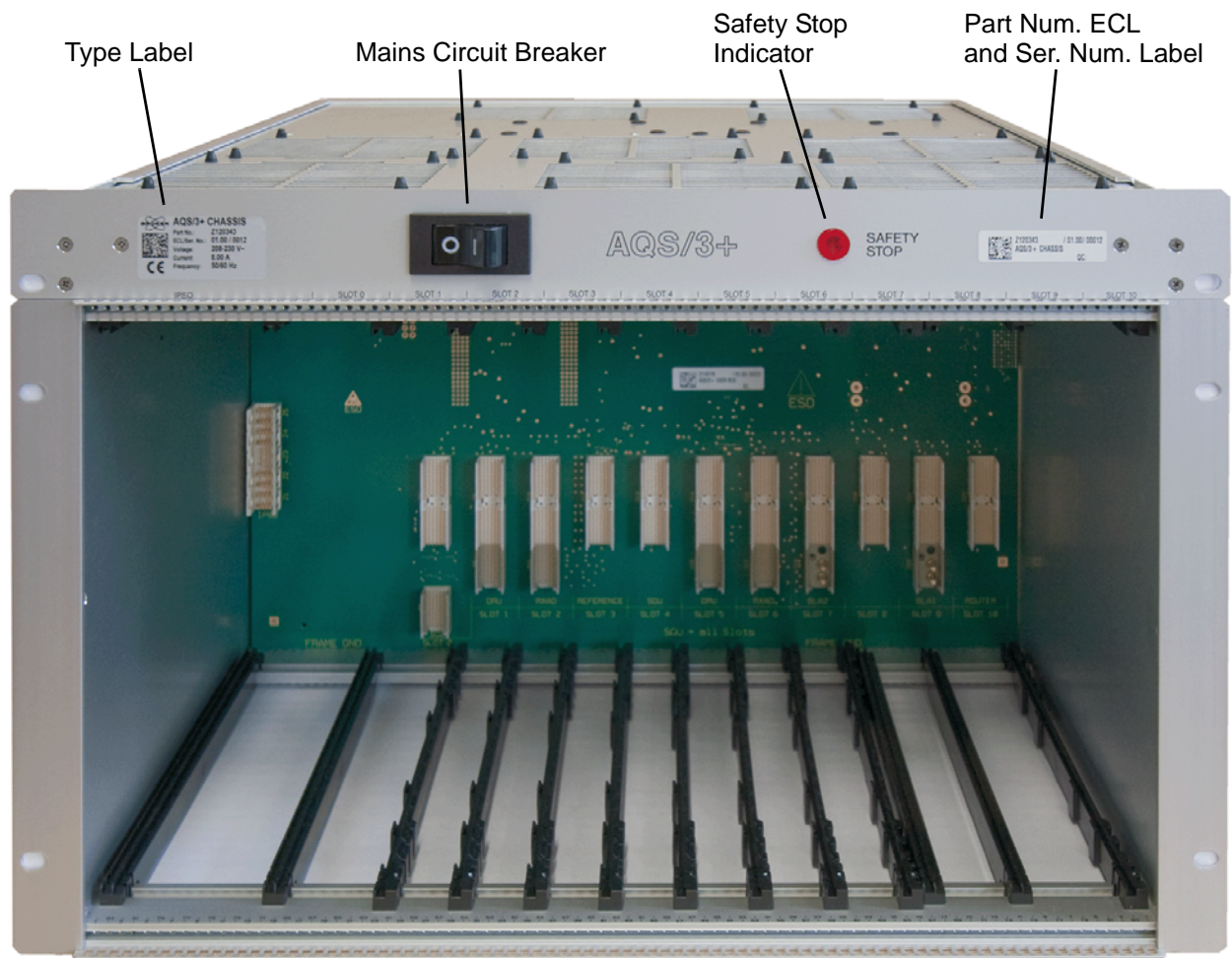

Figure 7.1 AQS/3+ Chassis front view

## 7.3 Rear View

The rear view shows the housing of the power supply boards. On the right hand side is the PSM-48V which is an integral part of the mainframe.

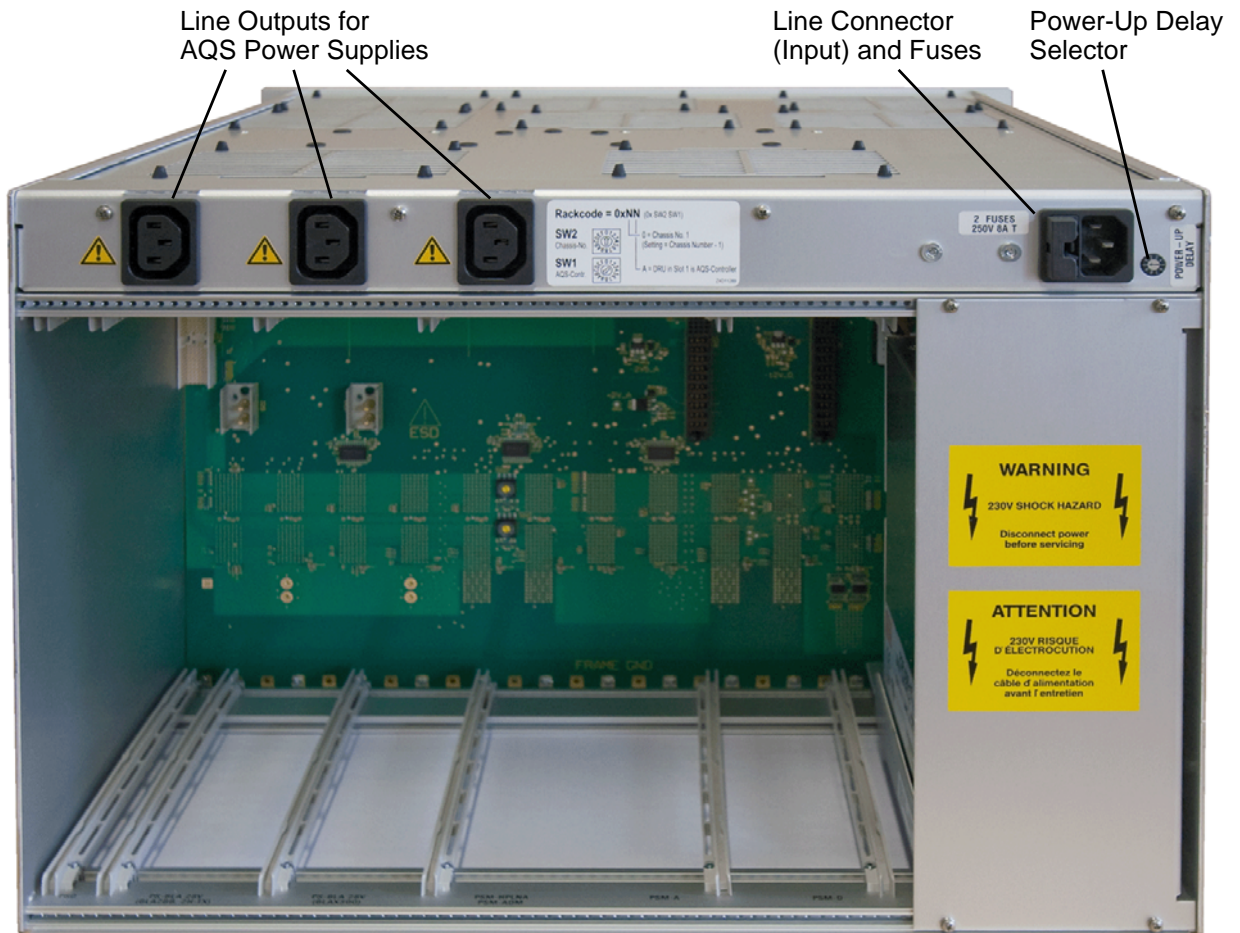

Figure 7.2 AQS/3+ Chassis rear view

### ⚠ CAUTION



**Only connect AQS power supply units to chassis rear connectors.**

- ▶ AQS PSM HPLNA (Z104783)
- ▶ AQS PSM ADM (Z107413)
- ▶ POWER SUPPLY COMPACT 28V 20A (W1345050)

Material damage may result if other units or devices are connected.

## 7.4 AC Power Line Fuses

---

The AQS/3+ is protected by two fuses. They are located in a removable fuse holder next to the AC power connector. For replacement always use time-lag T fuse types with high breaking capacity H.

## 7.5 Power-Up Delay

---

The power-up delay can be selected with a rotary switch next to the power connector at the back of the mainframe. Please set the switch according to your configuration as described in the configurations section within this manual. The minimal power-up delay is 0.5 sec due to the inrush current limiter circuit.

Setting	0	1	2	3	4	5	6	7	8	9
Delay in sec	0.5	2	4	6	8	10	12	14	16	18

Table 7.1 Power-Up Delay

## 7.6 Inrush Current Limiter

---

The mainframe is equipped with an inrush current limiter which limits the peak current to approx. 20 A. The limiter is always active, even after a „hot start“ when the chassis is switched OFF / ON within a short timespan.

## 7.7 Mains Power Failure & Restart Timeout

---

In the event of a short time mains power loss or a significant drop in the supply voltage the chassis turns itself of and, after the mains power is restored, restarts automatically with a timeout of 5 sec.

### NOTICE

#### Restart timeout:

The 5 sec timeout applies also when the chassis is switched off and on manually within a short interval.

To prevent short time power losses an external UPS (uninterruptible power supply) must be used.



## 7.8 Diagnostics & Setup

The AQS/3+ mainframe has several diagnostic and setup features controlled by the AQS controller and accessible via the AQS chassis page in the DRU service web.

- Device status (read only)
- Rackcodes settings (read only, see [page 77](#))
- Fan and power supply diagnostics (read only)
- Pulse switch setup (see [page 77](#))

### Device Status

Ready

### Rackcode Setting

AQS Control (SW1) = A  
Chassis-No. (SW2) = 0

Don't change the Rackcode Setting when the Chassis is powered on.

### Diagnostic Chassis 1

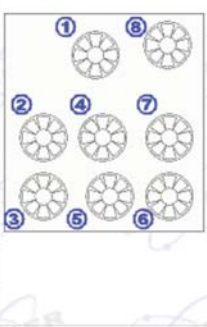
Fan	Status	Chassis Top View 	Power Supply	Status
①	running		PSM-A	ok
②	running		PSM-D	ok
③	running		PSM-48V	ok
④	running		Supply on Userbus	ok
⑤	running			
⑥	running			
⑦	running			
⑧	running			

Refresh F5

### Setup

Pulse Switch Setting

Switch1

Change

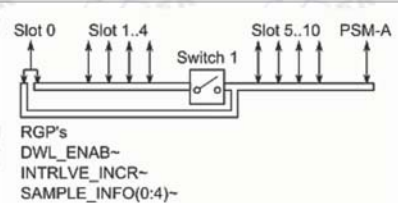

RGP's  
DWL\_ENAB~  
INTRLVE\_INCR~  
SAMPLE\_INFO(0:4)~

Figure 7.3 DRU Service Web: AQS Chassis Diagnostic

## 7.9 Safety Stop

If the temperature inside the mainframe exceeds the absolute maximum limit of safe operation, the mains supply to the chassis is switched off automatically (and without warning) to prevent permanent damage to the AQS units. This „Safety Stop“ condition is indicated with a red lamp on the front panel as long as the mains supply is present at the power connector.

**i** Make sure to establish and remove the cause of the Safety Stop condition before using the spectrometer again.

The Safety Stop can be caused by a fan or power supply failure within the mainframe. Other causes can be inefficient cooling air supply to the mainframe or exceeding ambient air temperatures within or around the spectrometer cabinet.

**⚠ CAUTION**

**Accident hazard from contact with hot surfaces on the unit.**

In case of a fan failure the surface of the subunits within the mainframe become very hot before the Safety Stop condition is triggered.

- ▶ Let the units cool down before handling
- ▶ Contact Bruker service personnel if you cannot establish the cause of the failure.

### 7.9.0.1 Safety Stop Reset

The chassis can be returned to its normal working state by switching the mains circuit breaker manually OFF and ON (be aware of the 5 sec timeout). An AC power loss also resets the chassis to its working state.

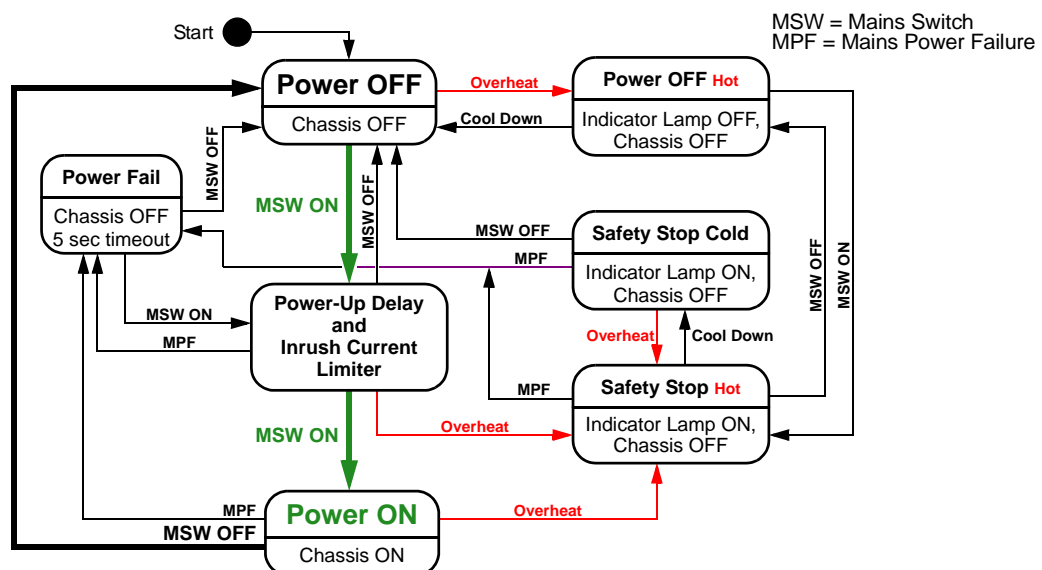
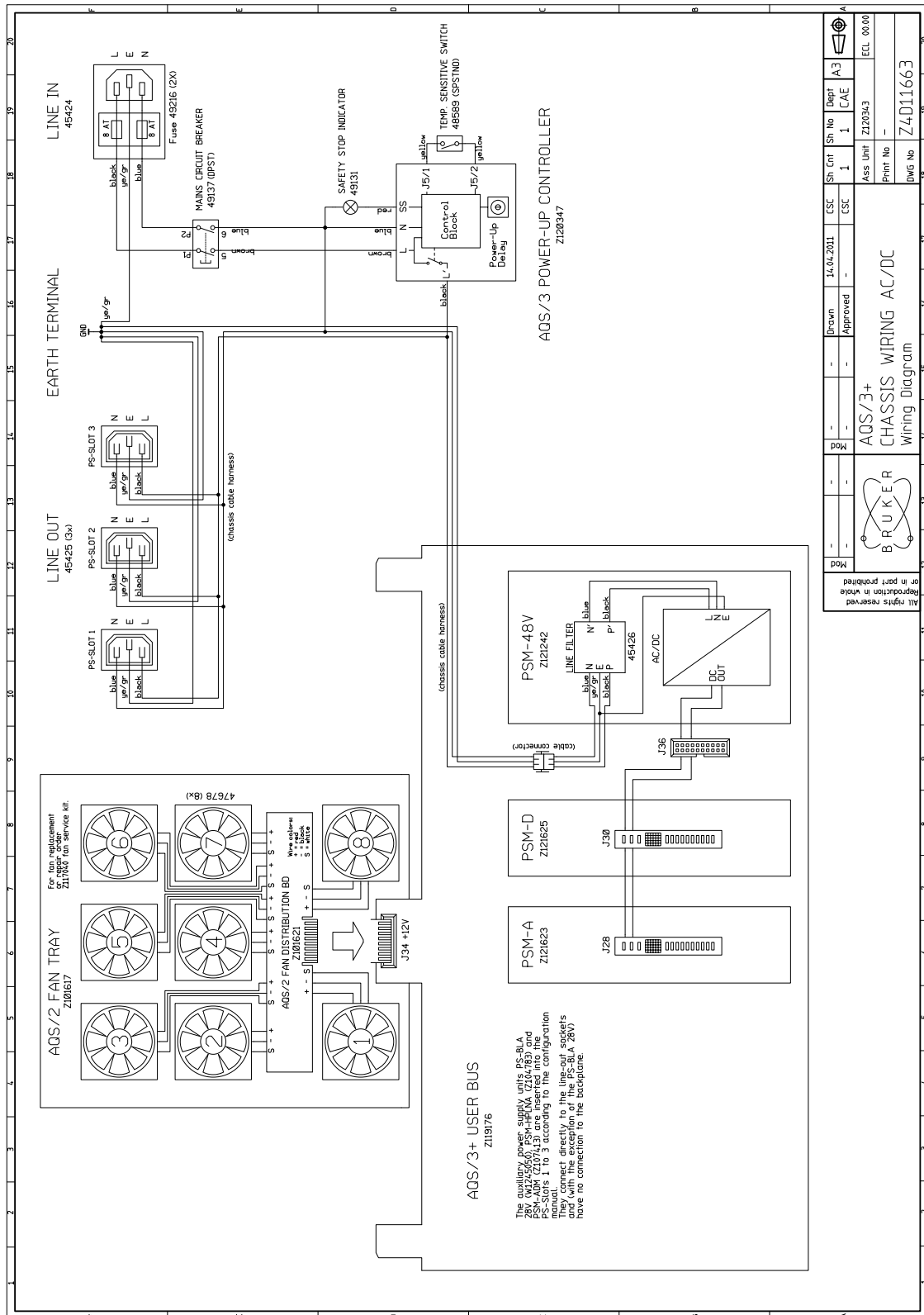

Figure 7.4 Safety Stop State Diagram

## 7.10 AC Wiring



Mod	-	Mod	-	Drawn	-	Sh. Cnt	1	Sh. No	1	Dept	CAE	Ass. Unit	Z120343	Print No	-	DWG No	Z4D11663
Mod	-	Mod	-	Approved	-	CSC	1	CSC	1								
<p>or in part prohibited</p> <p>All rights reserved</p> <p>BRUKER</p> <p>AQS/3+ CHASSIS WIRING AC/DC Wiring Diagram</p> <p>14.04.2011</p>																	

Figure 7.5 AQS/3+ AC Wiring

## 7.11 Backplane (User Bus)

The user bus is designed to route all signals and power supplies to the specific boards. It represents the ground point of the AQS/3+ and is connected to the chassis frame. For detailed information about user bus signals see ["AQS/3+ Signal and Information Paths" on page 27](#), ["Synchronous Signals" on page 30](#) and ["20 MHz Clock Distribution" on page 37](#).

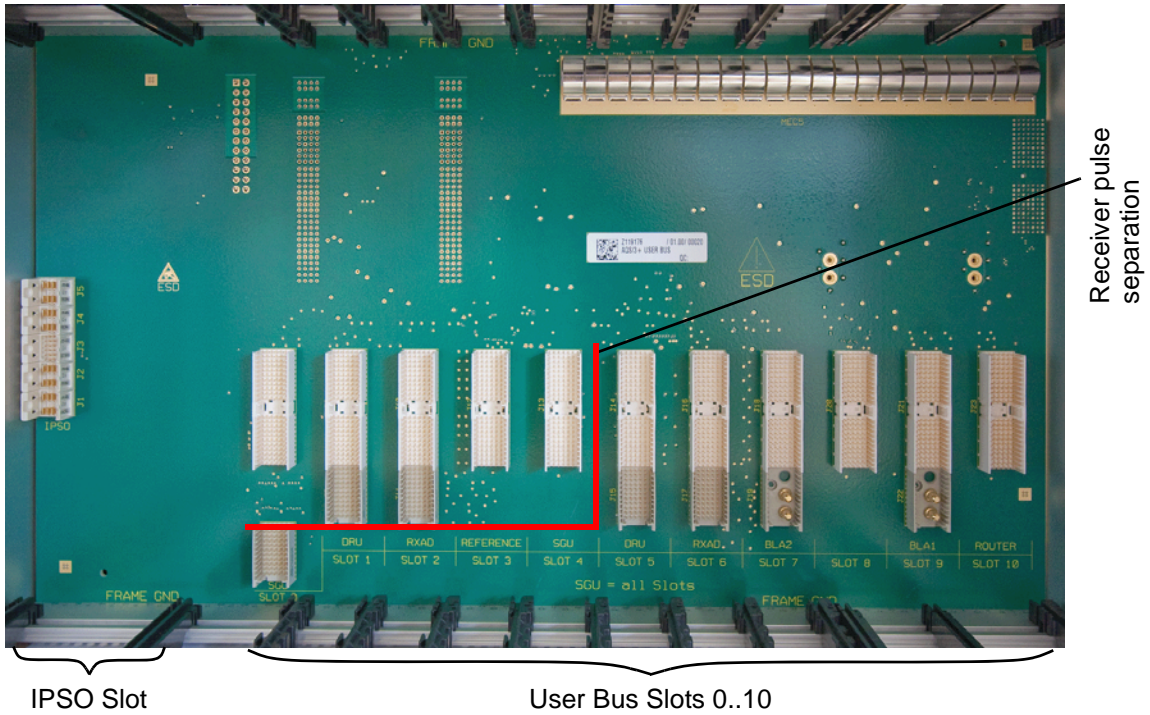

Figure 7.6 AQS/3+ User Bus (front view)

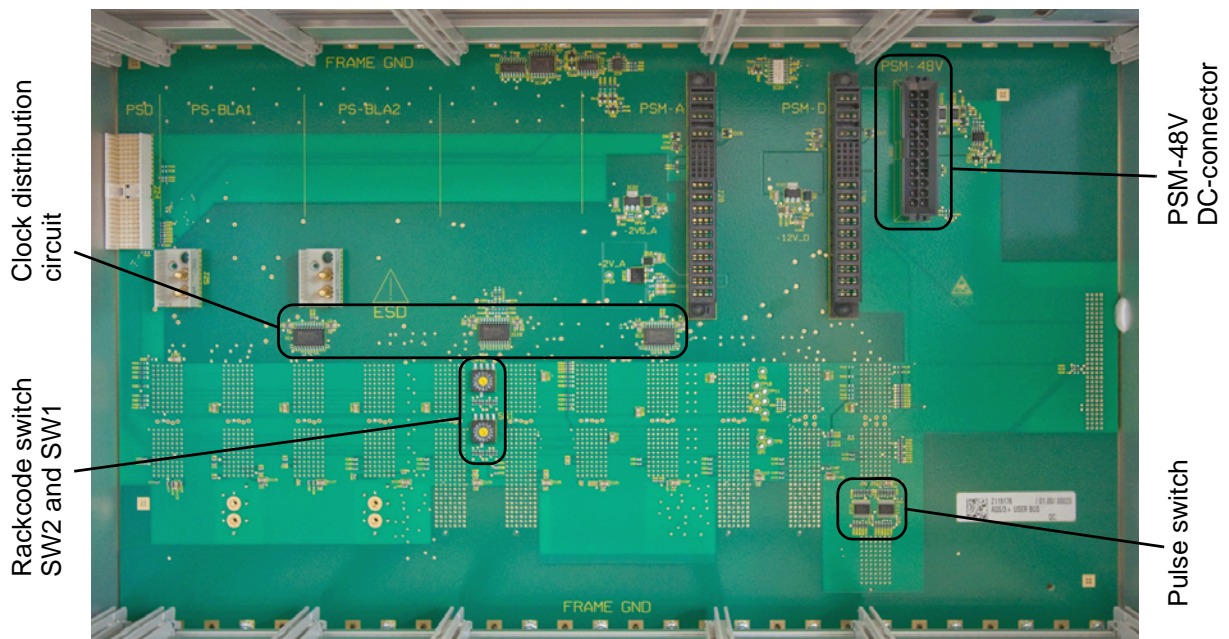

Figure 7.7 AQS/3+User Bus (rear view without PSM-48V)

### 7.11.1 Pulse Switch for Receiver Pulse Separation

The user bus is equipped with one pulse switch. It separates all receiver control pulses between slots 4 and 5. A SGU/3 in slot 0 can either feed two receivers with the same control pulses (switch closed) or two receivers with separate control pulses (switch open) via its additional backplane connector.

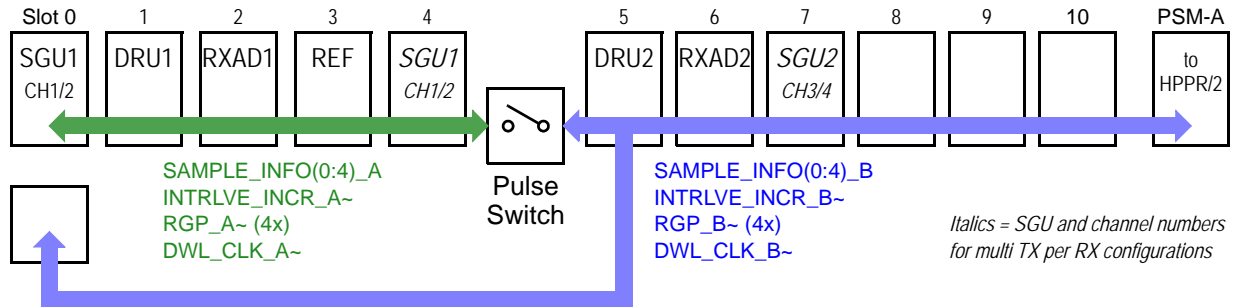

Figure 7.8 Pulse switch function

In multi receiver configurations with only two TX/RX channel, a single SGU/3 is placed in slot 0 to provide both TX channels. If more TX per RX channels are required, the SGU's are placed in slots 4 and 7 respectively, leaving slot 0 empty.

The switch status can be checked and set via the AQS controller only.

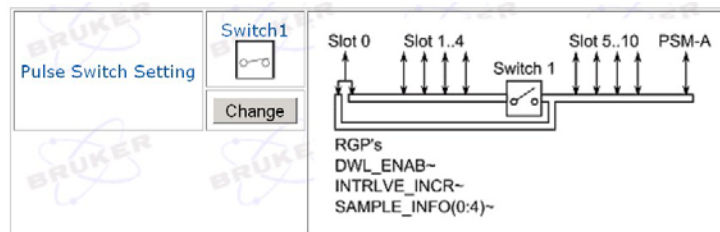

Figure 7.9 DRU Service Web: AQS Chassis Setup

### 7.11.2 Rackcode Settings

The rackcode must be set according to the chassis configuration as described in the configurations section of this manual.

Switch <sup>a</sup>	Function	Setting
<b>SW2</b>	Chassis Number (for DRU IP-Port numbering)	Chassis Number - 1
<b>SW1</b>	AQS Controller	A = DRU in Slot 1

Table 7.2 Rackcode Switch Function

a. Example setting: Rackcode 0x0A = Chassis 1 with DRU as AQS controller in Slot 1

## 7.12 Fans

The fans are located in the fan tray on top of the mainframe. They are supplied and controlled via the user bus. The fan tray is serviceable without removing the mainframe from the spectrometer cabinet. It has been introduced with the AQS/2 chassis, hence the name AQS/2 FAN TRAY. Since then adaptations to newer chassis generations have been made.

**i** Only use AQS/2 FAN TRAY (Z101617) with **ECL ≥ 04** as a replacement!

The "[Fan Tray Service Instructions](#)" can be found in the "[Maintenance](#)" section of this manual.

Single fans can be replaced using the AQS/2+AQS/3 CHASSIS FAN SERVICE KIT (Z117040).

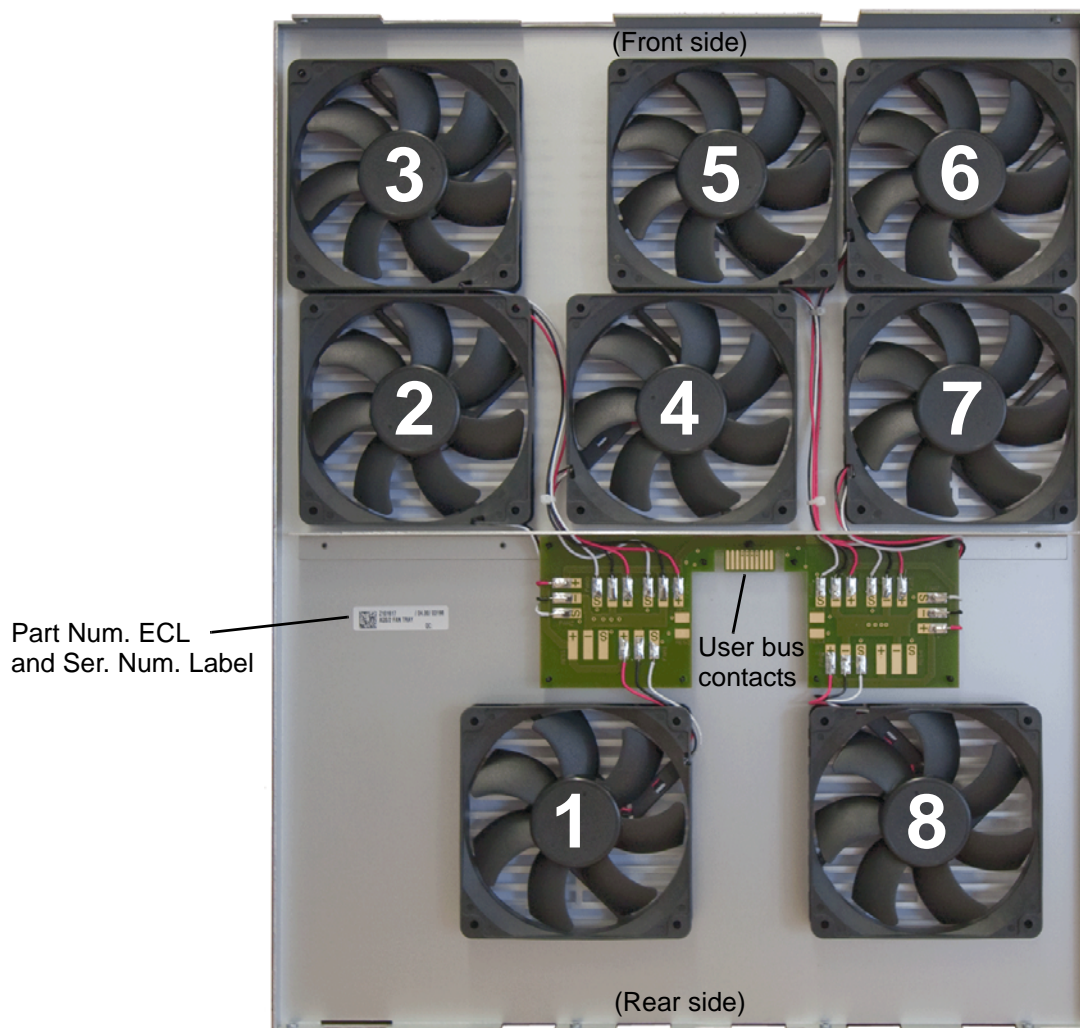

Figure 7.10 Fan Tray (Bottom view)

## 7.13 AC/DC Power Supply

---

The mainframe is delivered with a 48V AC/DC power supply module already installed on the rear side. However this power supply is a field exchangeable unit and can be replaced.

### 7.13.1 Product and Part Number

---

Product: AQS PSM-48V 600W POWER SUPPLY UNIT

Part No: Z121242

## 7.14 Power Supply Service Instruction

---

### 7.14.1 PSM-48V removal

---

To remove the PSM-48V from the mainframe follow the steps exactly as described below:

#### **WARNING**



#### **Electrical hazard from electrical shock.**

A life threatening shock may result when the housing is opened when under power!

- ▶ Turn of the chassis with mains circuit breaker
- ▶ Disconnect the chassis from the mains power supply before servicing.
- ▶ Be sure that the power supply cannot be reconnected without notice.

1. Remove the power supply modules PSM-A and PSM-D
2. Loosen the screws on the PSM-48V front panel
3. Pull the PSM a little forward and disconnect the two cable connectors inside as shown in [Figure 7.11](#)
4. Remove the PSM-48V completely from the mainframe



Figure 7.11 PSM-48V removal from mainframe

## 7.14.2 PSM-48V reassembly

To replace the PSM-48V in the mainframe follow the steps as described above in reverse order.

Make sure that:

- ▶ the PSM sits in both guide rails before final insertion
- ▶ both connectors are fully connected with their retaining clips clicked in place (the connectors are reverse polarity protected)
- ▶ no wires are squeezed in between the power supply housing and the mainframe
- ▶ the PSM-A and PSM-D are inserted at their proper place and all screws are tightened

Only then reconnect the AC power line and turn on the chassis.

- ▶ Check that both LED's of the PSM-A and PSM-D glow green after power up.



# 8 AQS/2-M Mainframe

## 8.1 Introduction

---

The AQS/2-M mainframe is commonly used as an extension chassis. One mainframe may contain up to 7 receiver channels (DRU and RXAD). It has 14 aqs-slot on the user bus.

---

**i** The AQS/2-M does not support double channel SGU/3 and REFERENCE/3 boards.

---

On the rear side, linear power supply modules (PSM1 & PSM5) and the switched power supply (PS Digital) are placed. One slot (AUX2) is reserved for the AQS RF-SPLITTER board.

The transformer, which feeds the linear power supply modules, is part of the mainframe and is located on the rear side.

The mainframe is cooled with 8 fans located in a fan tray on top of the mainframe. The fan tray is serviceable without removing the mainframe from the spectrometer cabinet. (see "[Fans](#)" on page 91)

## 8.2 Front View

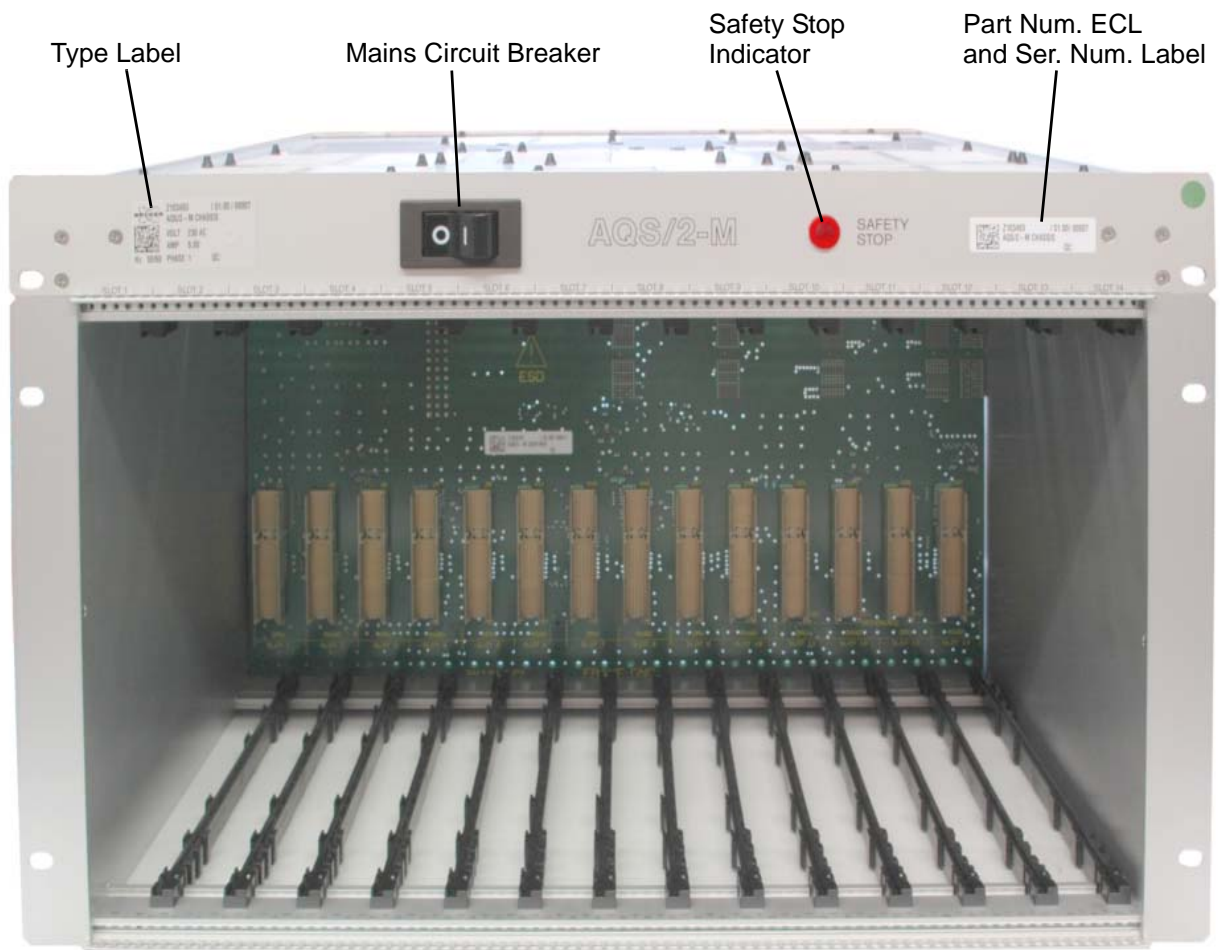

Figure 8.1 AQS/2-M Chassis front view

## 8.3 Rear View

The rear view shows the housing of the power supply boards. On the right hand side is the transformer housing with the appropriate AC cables.

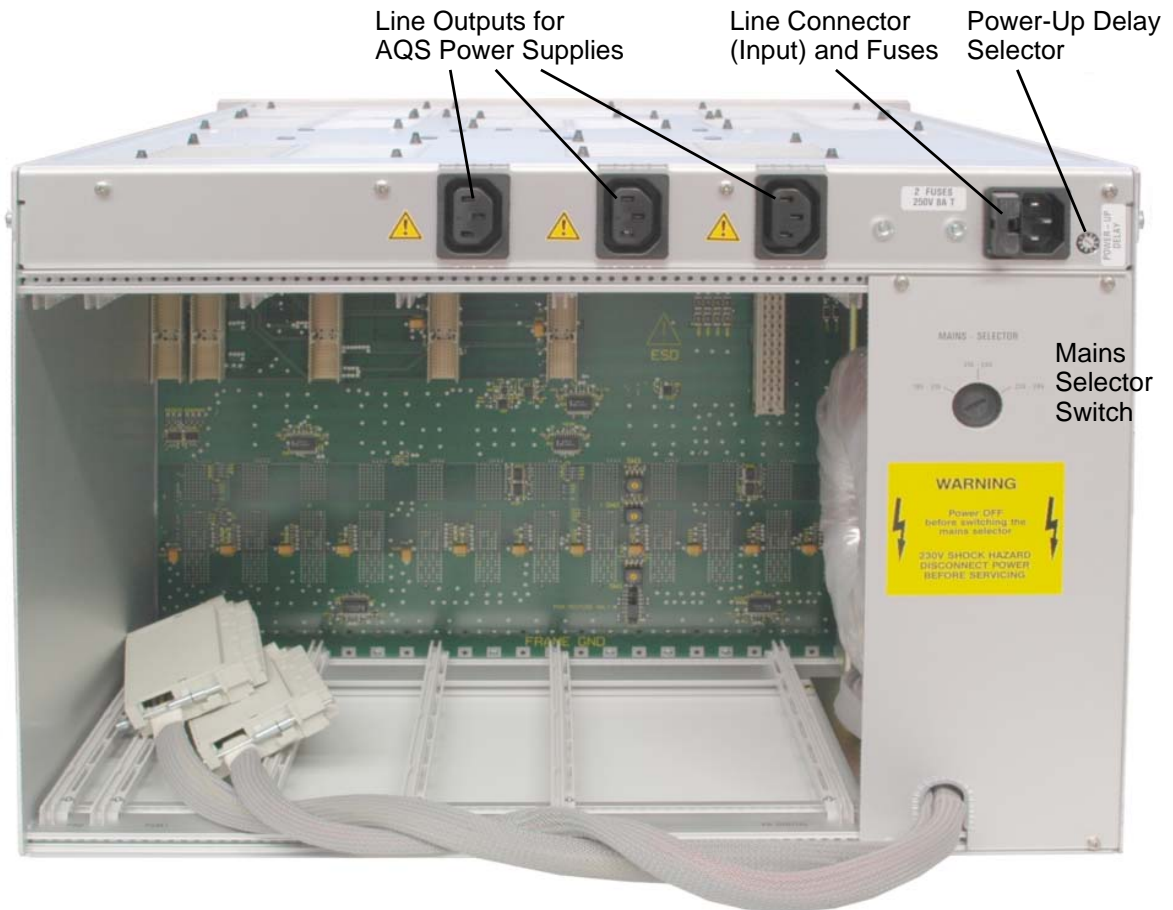

Figure 8.2 AQS/2-M Chassis rear view

### CAUTION



**Only connect AQS power supply units to chassis rear connectors.**

- ▶ AQS POWER SUPPLY DIGITAL 350W (H9489)
- ▶ AQS PSM5 POWER SUPPLY MODULE (Z102023)
- ▶ AQS PSM HPLNA (Z104783)
- ▶ AQS PSM ADM (Z107413)

Material damage may result if other units or devices are connected.

## 8.4 AC Power Line Fuses

---

The AQS/2-M is protected by two fuses. They are located in a removable fuse holder next to the AC power connector. For replacement always use time-lag T fuse types with high breaking capacity H.

## 8.5 Power-Up Delay

---

The power-up delay can be selected with a rotary switch next to the power connector at the back of the mainframe. Please set the switch according to your configuration as described in the configurations section within this manual. The minimal power-up delay is 0.5 sec due to the inrush current limiter circuit.

Setting	0	1	2	3	4	5	6	7	8	9
Delay in sec	0.5	2	4	6	8	10	12	14	16	18

Table 8.1 Power-Up Delay

## 8.6 Inrush Current Limiter

---

The mainframe is equipped with an inrush current limiter which limits the peak current to approx. 20 A. The limiter is always active, even after a „hot start“ when the chassis is switched OFF / ON within a short timespan.

## 8.7 Mains Power Failure

---

In the event of an AC power loss in the spectrometer cabinet, the chassis turns itself off and restarts automatically when the power is restored.

To prevent short time power losses an external UPS (uninterruptible power supply) must be used.

## 8.8 Diagnostics & Setup

The AQS/2-M mainframe has several diagnostic and setup features controlled by the AQS controller and accessible via the AQS chassis page in the DRU service web.

- Device status (read only)
- Fan and power supply diagnostics (read only)
- Pulse switch setup (see [page 90](#))

**Diagnostic**

Fan	Status	Chassis Top View
①	running	
②	running	
③	running	
④	running	
⑤	running	
⑥	running	
⑦	running	
⑧	running	
Update	<input type="button" value="Update"/>	

**Setup**

Pulse Switch Setting *	Switch1	Switch2	Switch3	
	<input type="checkbox"/>	<input type="checkbox"/>	<input type="checkbox"/>	
	<input type="button" value="Change"/>	<input type="button" value="Change"/>	<input type="button" value="Change"/>	

Figure 8.3 DRU Service Web: AQS Chassis Diagnostic

## 8.9 Safety Stop

If the temperature inside the mainframe exceeds the absolute maximum limit of safe operation, the mains supply to the chassis is switched off automatically (and without warning) to prevent permanent damage to the AQS units. This „Safety Stop“ condition is indicated with a red lamp on the front panel as long as the mains supply is present at the power connector.

- i** Make sure to establish and remove the cause of the Safety Stop condition before using the spectrometer again.

The Safety Stop can be caused by a fan or power supply failure within the mainframe. Other causes can be inefficient cooling air supply to the mainframe or exceeding ambient air temperatures within or around the spectrometer cabinet.

**⚠ CAUTION**



**Accident hazard from contact with hot surfaces on the unit.**

In case of a fan failure the surface of the subunits within the mainframe become very hot before the Safety Stop condition is triggered.

- ▶ Let the units cool down before handling
- ▶ Contact Bruker service personnel if you cannot establish the cause of the failure.

### 8.9.0.1 Safety Stop Reset

The chassis can be returned to its normal working state by switching the mains circuit breaker manually OFF and ON. An AC power loss also resets the chassis to its working state.

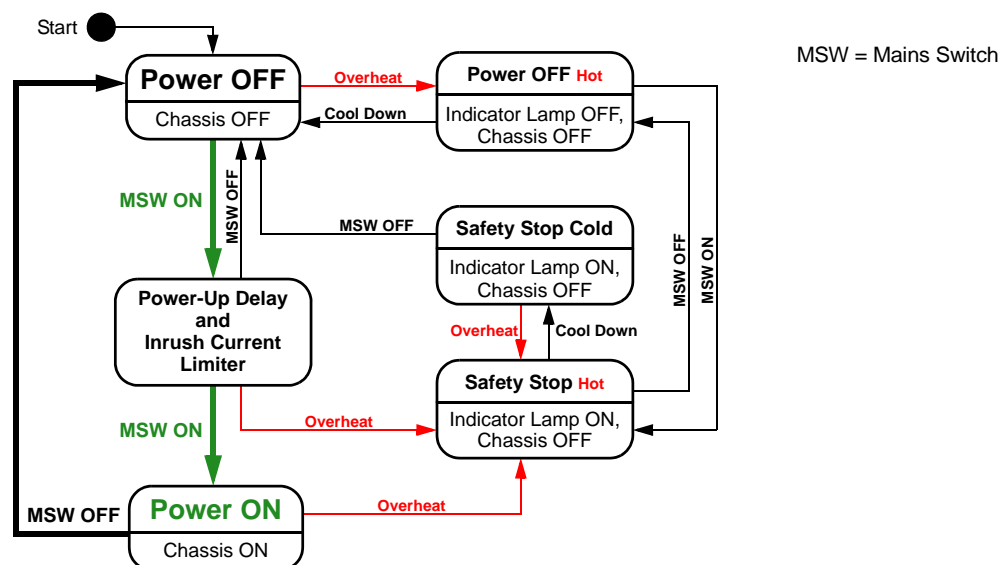

Figure 8.4 Safety Stop State Diagram

8.10 AC Wiring

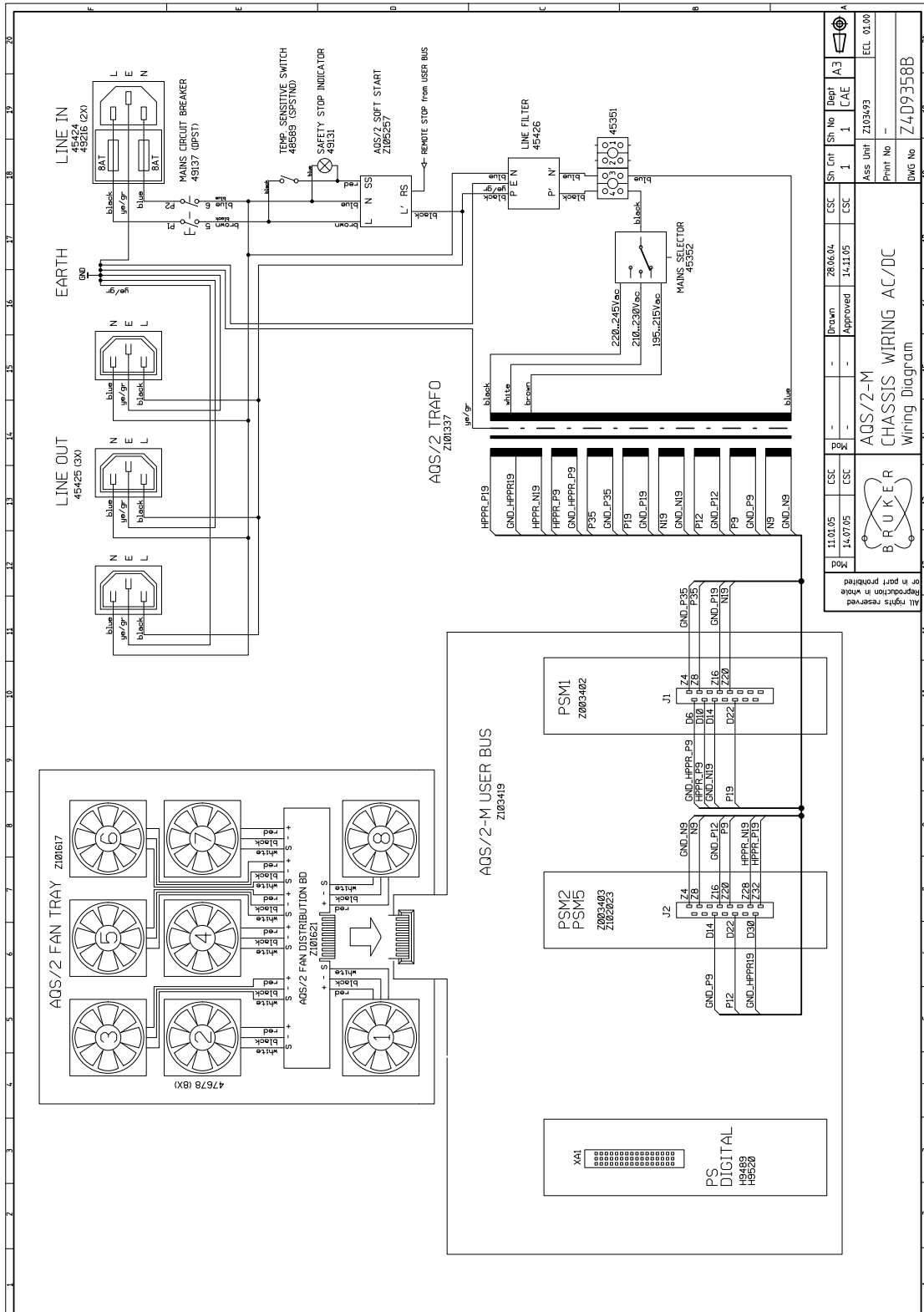

Figure 8.5 AQS/2-M AC Wiring

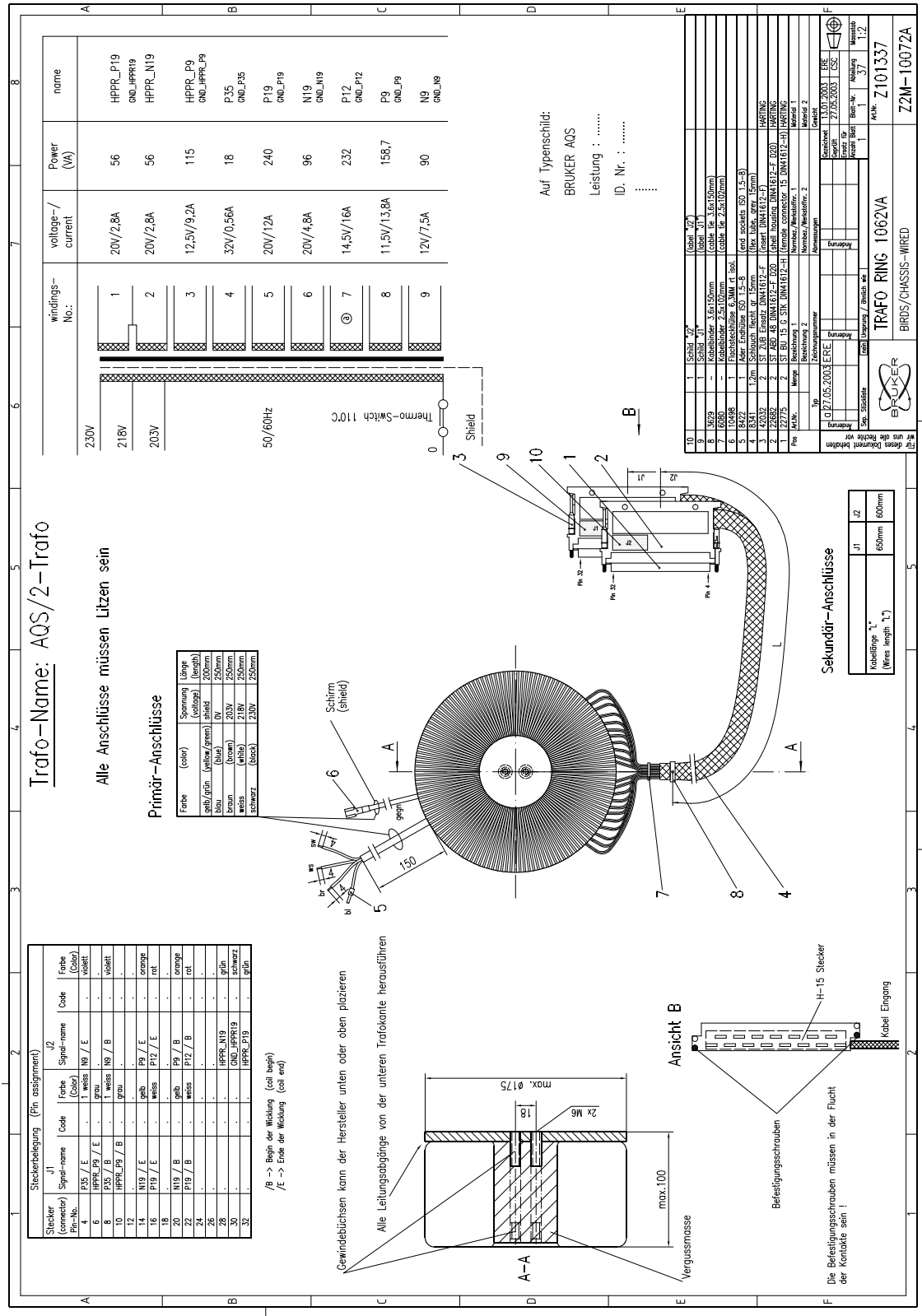

Figure 8.6 AQS/2 Transformer



### 8.11 Backplane (User Bus)

The user bus is designed to route all signals and power supplies to the specific boards. It represents the ground point of the AQS/2-M and is connected to the chassis frame. For detailed information about user bus signals see ["AQS/3+ Signal and Information Paths" on page 27](#), ["Synchronous Signals" on page 30](#) and ["20 MHz Clock Distribution" on page 37](#).

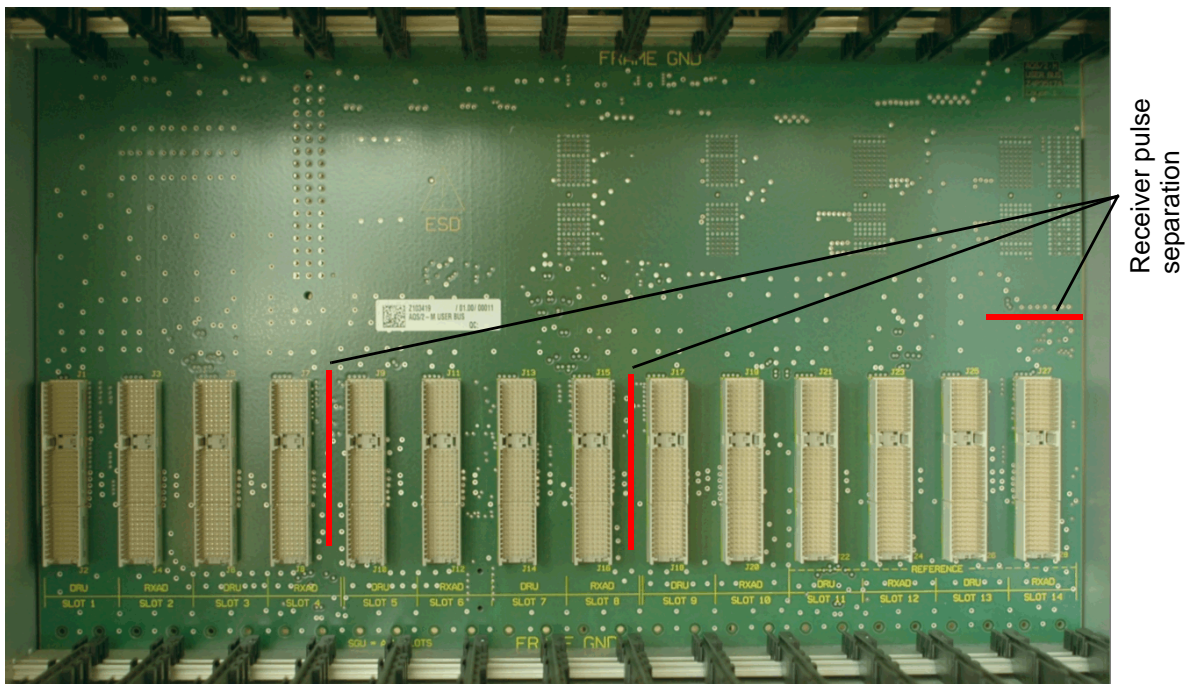

Figure 8.7 AQS/2-M User Bus (front view)

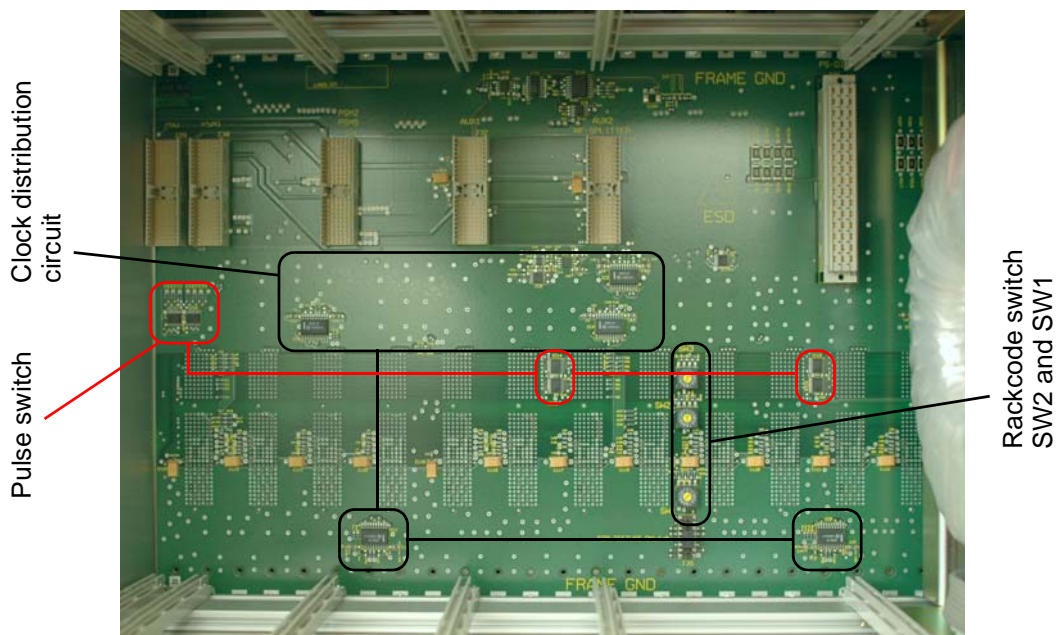

Figure 8.8 AQS/2-M User Bus (rear view)

## 8.11.1 Pulse Switch for Receiver Pulse Separation

The user bus is equipped with three pulse switches. One is located between slots 4 and 5, another between slots 8 and 9 and the third between slot 14 and the PSD slot. All switches are either controlled via the AQS controller or with a rotary switch (SW2) on the rear side of the user bus.

The switch status can be checked and set via the AQS controller.

### Setup

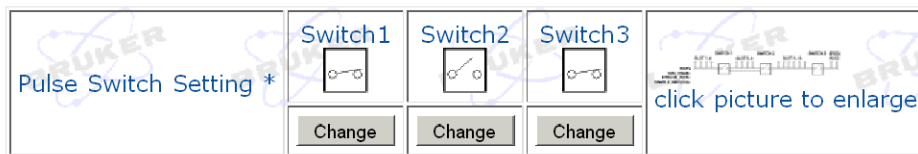

Figure 8.9 DRU Service Web: AQS Chassis Setup

## 8.11.2 Rackcode Settings

The rackcode must be set according to the chassis configuration as described in the configurations section of this manual.



Switch <sup>a</sup>	Function	Setting																								
<b>SW2</b> 	Chassis Number (for DRU IP-Port numbering)	Chassis Number - <b>1</b>																								
<b>SW2</b> 	Clk Source BACK = RF-Splitter Clk Source FRONT = REF-Board	<table border="1"> <tr> <td><b>0</b></td> <td>1</td> <td>2</td> <td>3</td> <td>4</td> <td>5</td> <td>6</td> <td>7</td> </tr> <tr> <td>8</td> <td>9</td> <td>A</td> <td>B</td> <td>C</td> <td>D</td> <td>E</td> <td>F</td> </tr> </table>	<b>0</b>	1	2	3	4	5	6	7	8	9	A	B	C	D	E	F								
<b>0</b>	1	2	3	4	5	6	7																			
8	9	A	B	C	D	E	F																			
	Pulse Switch 1 = Slot 4 // 5 <sup>b</sup> Pulse Switch 2 = Slot 8 // 9 Pulse Switch 3 = Slot 14 // PSD	<table border="1"> <tr> <td>O</td> <td>X</td> <td>O</td> <td>X</td> <td>O</td> <td>X</td> <td>O</td> <td>X</td> </tr> <tr> <td>O</td> <td>O</td> <td>X</td> <td>X</td> <td>O</td> <td>O</td> <td>X</td> <td>X</td> </tr> <tr> <td>O</td> <td>O</td> <td>O</td> <td>O</td> <td>X</td> <td>X</td> <td>X</td> <td>X</td> </tr> </table>	O	X	O	X	O	X	O	X	O	O	X	X	O	O	X	X	O	O	O	O	X	X	X	X
O	X	O	X	O	X	O	X																			
O	O	X	X	O	O	X	X																			
O	O	O	O	X	X	X	X																			
<b>SW1</b> 	AQS Controller	<b>2</b> = DRU in Slot 1																								

Table 8.2 Rackcode Switch Function

a. Example setting: Rackcode 0x102 = Chassis no. is 2, clock source is RF-Splitter, all pulse switches are remote controlled and the DRU in Slot 1 is AQS controller.

b. O = open or remote controlled, X = permanently closed

## 8.12 Fans

The fans are located in the fan tray on top of the mainframe. They are supplied and controlled via the user bus. The fan tray is serviceable without removing the mainframe from the spectrometer cabinet. It has been introduced with the AQS/2 chassis, hence the name AQS/2 FAN TRAY. Since then adaptations to newer chassis generations have been made.

**i** Only use AQS/2 FAN TRAY (Z101617) with **ECL ≥02** as a replacement!

The "[Fan Tray Service Instructions](#)" can be found in the "[Maintenance](#)" section of this manual.

Single fans can be replaced using the AQS/2+AQS/3 CHASSIS FAN SERVICE KIT (Z117040).



Figure 8.10 Fan Tray (Bottom view)



# 9 Power Supply System

## 9.1 System Overview

### 9.1.1 AQS/3+ Chassis PSM

The power supply system of the AQS/3+ chassis consists of one ac/dc, two dc/dc and several auxiliary ac/dc power supply modules (PSM). The auxiliary power supplies are used according to the chassis configuration.

Type	Part Number	Description
AC/DC	Z121242	AQS PSM-48V 600W POWER SUPPLY UNIT
DC/DC	Z133424 <sup>a</sup>	AQS PSM-A2 POWER SUPPLY MODULE
	Z121625	AQS PSM-D POWER SUPPLY MODULE
Auxiliary AC/DC	Z104783	AQS PSM HPLNA
	Z107413	AQS PSM ADM
	W1345050	POWER SUPPLY COMPACT 28V 20A (PS-BLA)

Table 9.1 AQS/3+ power supply part numbers

a. for HPPR/2 assemblies with COVER modules Z003356 or Z103945 use AQS PSM-A Z121623

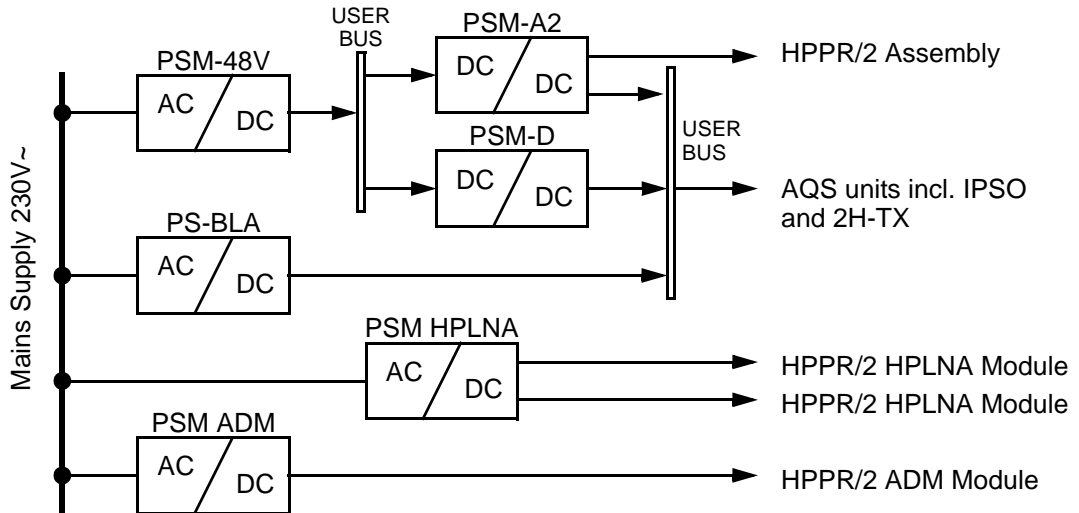

Figure 9.1 Power supply system overview

## 9.1.2 AQS/2-M Chassis PSM

The power supply system of the AQS/2-M chassis consists of one ac/dc, two linear and several auxiliary ac/dc power supply modules. The linear PSM are fed from a transformer in the mainframe.

The auxiliary power supplies are the same as in the AQS/3+ chassis.

Type	Part Number	Description
AC/DC	H9520	AQS POWER SUPPLY DIGITAL 450W
Linear	Z003403	AQS PSM2 POWER SUPPLY MODULE
	Z102023	AQS PSM5 POWER SUPPLY MODULE

Table 9.2 AQS/2-M power supply part numbers

## 9.1.3 PSM Summary Table

Shortname	Supply Output						Power	Load
PSM-48V	<u>+48V</u> 12.5 A						600 W	PSM-A, PSM-D
PSM-A / A2	<u>+9V</u> 13 A	<u>-9V</u> 1.5 A	<u>+19V</u> 5.0 A	<u>-19V</u> 2.0 A	<u>+35V</u> 0.5 A	<u>+9V HPPR</u> 5.0 A	300 W <sup>a</sup>	AQS units including AQS IPSO and AQS Preamp <a href="#">ext. HPPR Assembly</a>
PSM-D	<u>+12V</u> 8.0 A	<u>+5V</u> 25 A	<u>+3.6V</u> 25 A	<u>+3.3V</u> 8.0 A			300 W	AQS units, Fan
Supply on AQS/3+ USERBUS (supplied from PSM-A)	<u>+2V</u> 0.5 A	<u>-2.5V</u> 0.5 A	<u>-12V</u> 0.2 A				5 W	AQS units
PS DIGITAL 450W	<u>+5V</u> 50A	<u>+5V</u> 14A	<u>+12V</u> 9A	<u>-12V</u> 3A			460W	Fan, USER BUS
PSM1	<u>+2V</u> 0.5A	<u>-2.5V</u> 0.2A	<u>+19V</u> 6.4A	<u>-19V</u> 2.5A	<u>+9V</u> 5A	<u>+35V</u> 0.2A	220W	USER BUS <a href="#">HPPR</a>
PSM5	<u>+19V</u> 1.5A	<u>-19V</u> 1.5A	<u>+12V</u> 17A	<u>+9V</u> 7.3A	<u>-9V</u> 3.9A		470W	USER BUS <a href="#">HPPR</a>
PSM HPLNA	<u>+500V</u> 0.2 A	<u>+20V</u> 0.1 A	<u>-5V</u> 3.0 A				117 W	HPPR/2 HPLNA (max. 2 modules)
PSM ADM	<u>+7.5V</u> 10 A	<u>+19V</u> 2.0 A	<u>-19V</u> 1.0 A	<u>-36V</u> 1.0 A	<u>-60V</u> 1.0 A		228 W	HPPR/2 ADM
PS BLA 28V	<u>+28V</u> 20 A						560 W	internal BLA (pulsed power)

Table 9.3 Power supply module output specification (short form)

a. The total output power of the module shall not exceed 300W.

## 9.2 AQS PSM-48V 600W POWER SUPPLY UNIT

- i** This unit is delivered as an integral part of the AQS/3+ chassis. It can be replaced for repairs as a field exchangeable unit.

The PSM-48V unit consists of an ac-input filter and a compact switched mode AC/DC power supply module with a single 48V output. The ac-input connects directly to the internal cable harness of the chassis. The dc-output connects to the backplane.

The supply status is not indicated on the front panel.

The unit has no serviceable parts or fuses.



Figure 9.2 Overview PSM-48V <sup>a</sup>

a. The interior view of the unit may look different depending on subcomponents from other manufacturers.

## 9.3 AQS PSM-A2 POWER SUPPLY MODULE

The PSM-A2 module consists of several hybrid DC/DC power supplies on a printed circuit board. The 48V input and most outputs connect to the backplane.

The module incorporates the functions of the former AQS PSD/3 board. The connectors for the external HPPR/2 assembly including its power supply, the power amplifier blanking pulses and the EMERGENCY and TPF0 signals are on the front panel.

The supply status is indicated with one LED on the front panel. It can also be checked via the AQS chassis page on the DRU service web.

The units has no serviceable parts except two fuses.

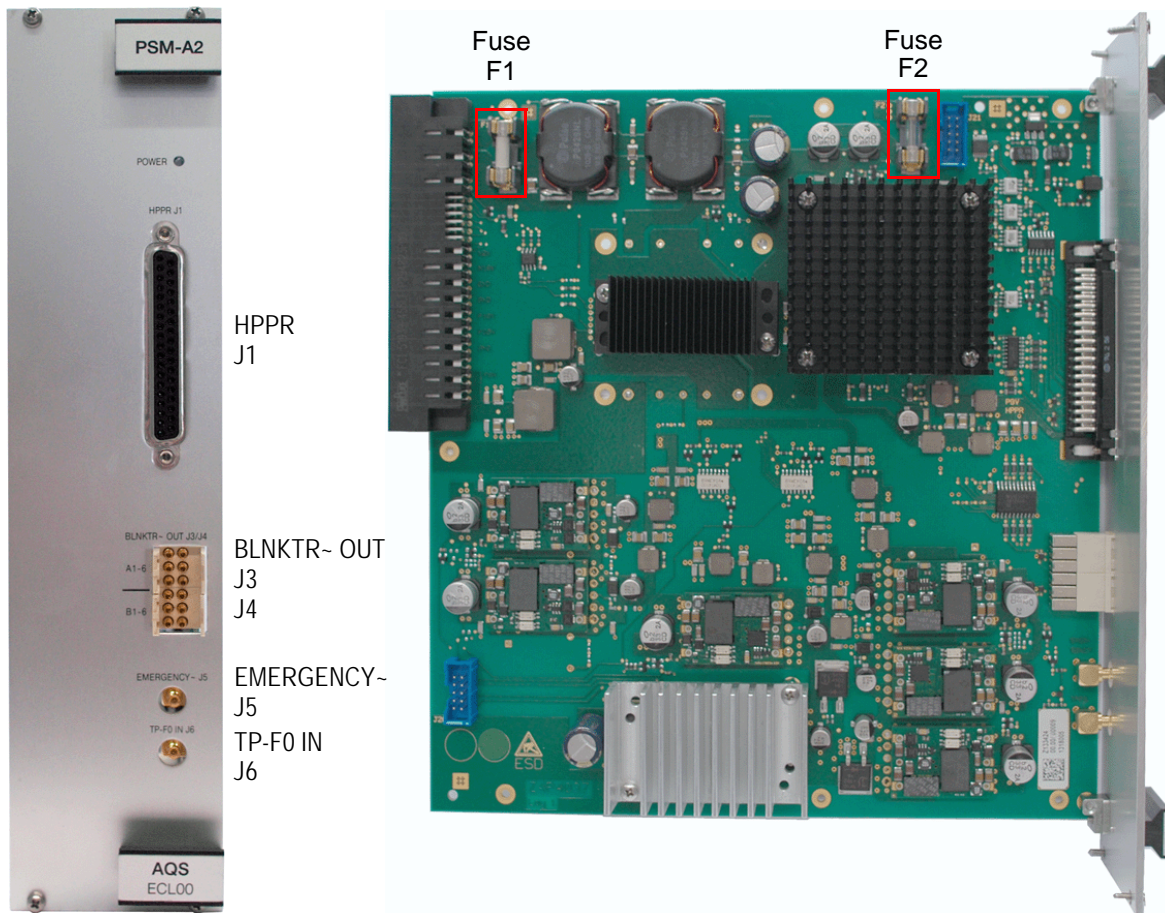

Figure 9.3 Overview PSM-A2

Supply	Fuse	Mat. Nb.	Value
+48V Input	F1	49216	8.0 AT H
+9V HPPR Output	F2	1801422	5.0 AT

Table 9.4 Fuses PSM-A2



Pin	Signal	Pin	Signal	Pin	Signal	Pin	Signal
1	N19V_HPPR	11	GND_HPPR	20	N19V_HPPR	30	GND_HPPR
2	N19V_HPPR	12	GND_HPPR	21	N19V_HPPR	31	BFB_RX-_HPPR
3	GND	13	BFB_RX+_HPPR	22	GND	32	BFB_TX-_HPPR
4	P19V_HPPR	14	BFB_TX+_HPPR	23	P19V_HPPR	33	EMERGENCY_STOP
5	P19V_HPPR	15	EMERGENCY_STOP-	24	P19V_HPPR	34	GND_HPPR
6	GND	16	GND_HPPR	25	GND	35	INTRLVE_INCR~
7	GND_HPPR	17	INTRLVE_INCR	26	P9V_HPPR_SENSE	36	LOCK_PP~
8	P9V_HPPR	18	LOCK_PP	27	P9V_HPPR	37	RGP_HPPR~
9	P9V_HPPR	19	RGP_HPPR	28	P9V_HPPR		
10	P9V_HPPR			29	GND_HPPR_SENSE		

Table 9.5 Pinout HPPR connector J1

Pin	Signal	Pin	Signal	Pin	Signal	Pin	Signal
A1	BLNKTR1~	A4	BLNKTR4~	B1	BLNKTR7~	B4	NC
A2	BLNKTR2~	A5	BLNKTR5~	B2	BLNKTR8~	B5	NC
A3	BLNKTR3~	A6	BLNKTR6~	B3	NC	B6	NC

Table 9.6 Pinout BLNKTR~ OUT connector J3 / J4

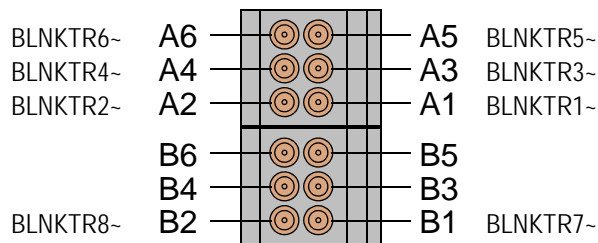

Figure 9.4 Front view BLNKTR~ OUT connector J3 / J4

## 9.3.1 AQS PSM-A POWER SUPPLY MODULE

The PSM-A is functionally the same as the PSM-A2, except for different HPPR connectors. It is only used for HPPR/2 assemblies with COVER modules Z003356 or Z103945.

Fuse information see [Table 9.4](#).

## 9.4 AQS PSM-D POWER SUPPLY MODULE

The PSM-D module consists of several hybrid DC/DC power supplies on a printed circuit board. The 48V input and all outputs connect to the backplane.

The supply status is indicated with one LED on the front panel. It can also be checked via the AQS chassis page on the DRU service web.

The units has no serviceable parts except one fuse.

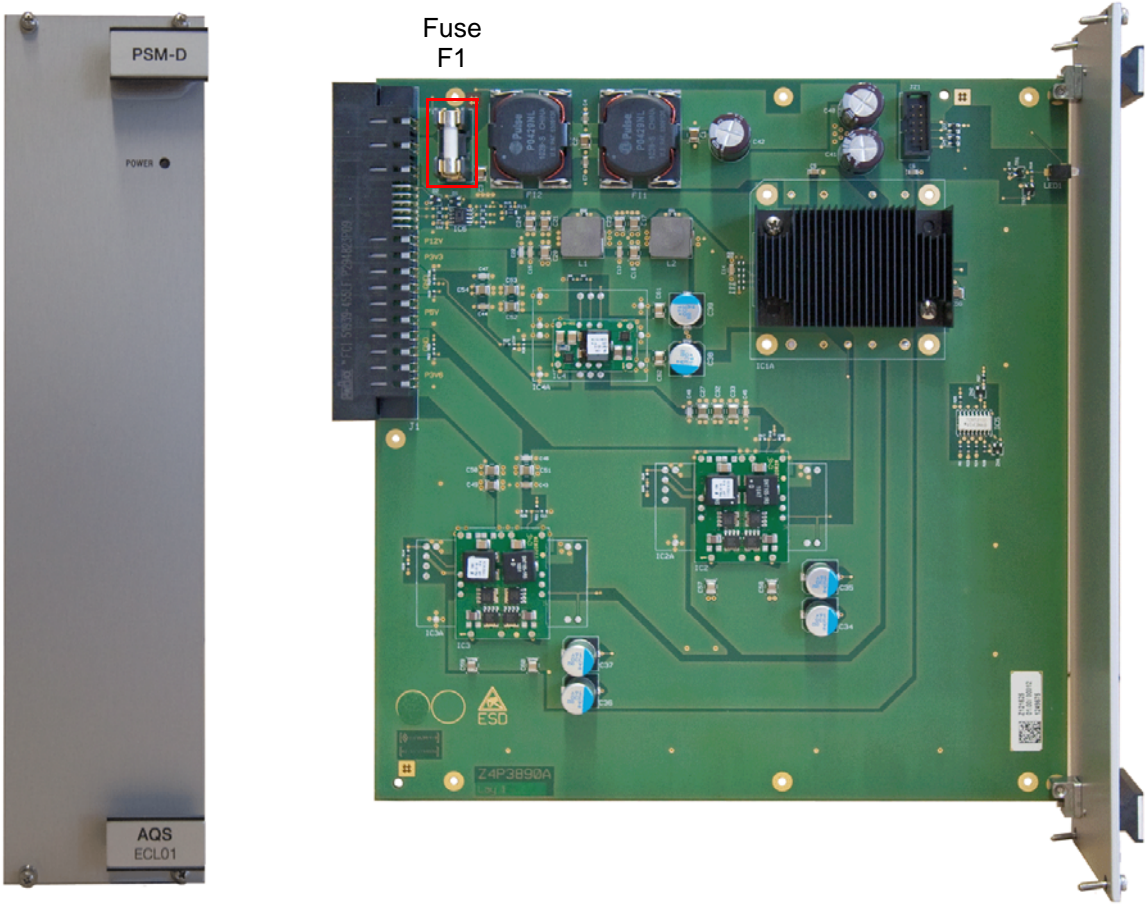

Figure 9.5 Overview PSM-D

Supply	Fuse	Mat. Nb.	Value
+48V Input	F1	49216	8.0 AT H

Table 9.7 Fuses PSM-D

## 9.5 AQS POWER SUPPLY DIGITAL

The unit consist of a compact switched mode power supply module with multiple outputs. The ac-input cable connects to the line output socket at the rear side of the chassis. The dc-outputs connect to the backplane.

The supply status is indicated with LED's on the front panel.

The unit has no serviceable parts or fuses.



Figure 9.6 View POWER SUPPLY DIGITAL

## 9.6 AQS PSM1 POWER SUPPLY MODULE

The linear power supply module PSM1 consist of rectifiers and linear regulators mounted on an open print. The ac-inputs connects directly to the transformer in the chassis via a front panel connector. The dc-outputs connect to the backplane.

The supply status is indicated with LED's on the front panel.

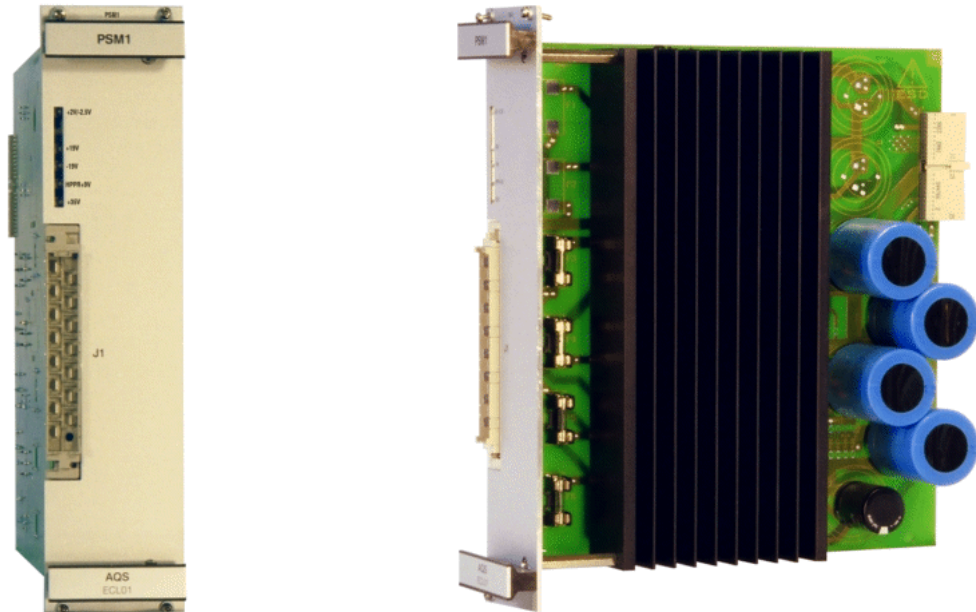

Figure 9.7 Overview PSM1

SUPPLY	FUSE	CAT_NM	VALUE
+19V	F3	2259	8.0 AT
-19V	F4	2256	3.15 AT
HPPR +9V	F5	4907	5 AT
+35V	F6	2248	0.5 AT <sup>a</sup>

Table 9.8 Fuses PSM1

a. prior fuse was 0.315 AT

## 9.7 AQS PSM5 POWER SUPPLY MODULE

The power supply module PSM5 consist largely of rectifiers and linear regulators mounted on an open print. The ac-inputs connects directly to the transformer in the chassis via a front panel connector. The +12V supply is taken from a compact switched power supply module. It's ac-input cable connects directly to the line output socket at the rear side of the chassis. All dc-outputs connect to the backplane.

The supply status is indicated with LED's on the front panel.

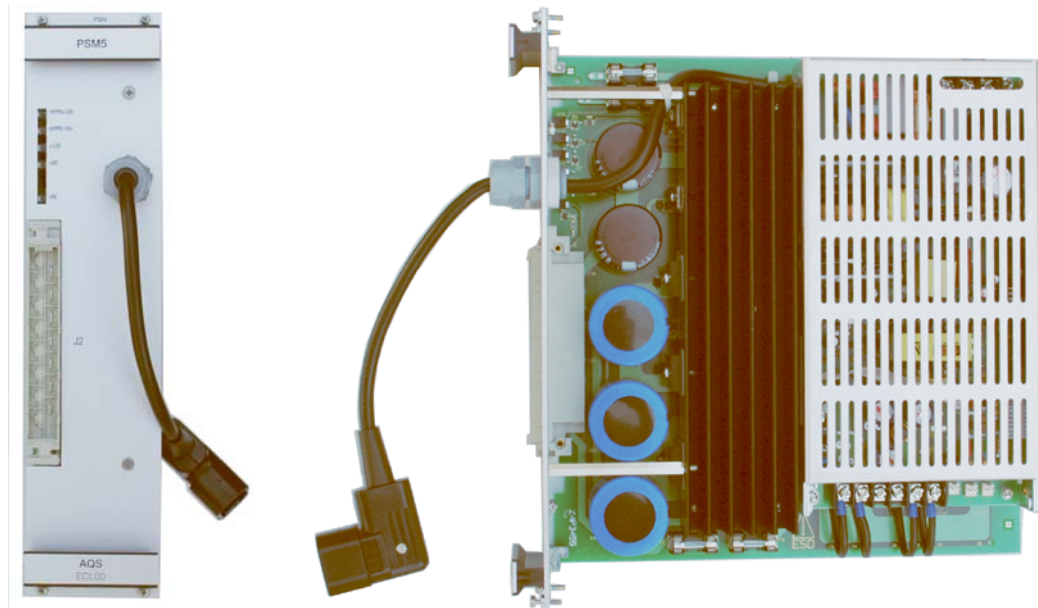

Figure 9.8 Overview PSM5

SUPPLY	FUSE	CAT_NM	VALUE
HPPR +19V	F1	2254	2AT
HPPR -19V	F2	2254	2AT
+9V	F3	2260	10 AT <sup>a</sup>
-9V	F4	4907	5AT

Table 9.9 Fuses PSM5

a. prior fuse was 8.0 AT

---

**i** The +12V supply from the switched power supply module has no serviceable fuse.

---

## 9.8 AQS PSM HPLNA

The PSM HPLNA is a compact switched mode AC/DC power supply module with multiple outputs. The input cable connects directly to the line output socket at the rear side of the chassis. The dc-outputs connect to two D-SUB connectors with high-voltage pins on the front panel.

The supply status is indicated with LED's on the front panel.

The unit has no serviceable parts or fuses.

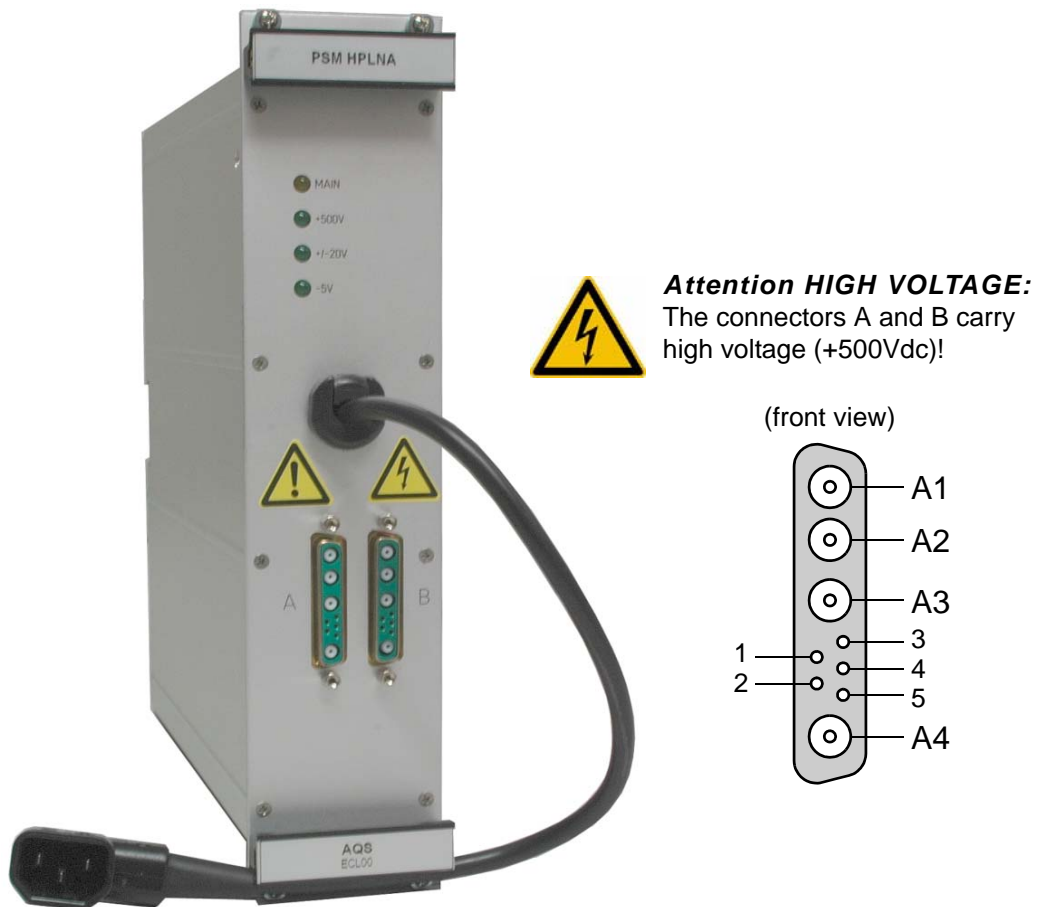

Figure 9.9 View PSM HPLNA

Pin	Signal	Pin	Signal	Pin	Signal
A1	+ 500V	A4	GND1 (500V)	3	SENSE GND2
A2	+ 20V (floating)	1	SENSE -5V	4	GND2 (-5V)
A3	- 20V (floating)	2	-5V	5	NC

Table 9.10 Pinout ADM POWER connector

## 9.9 AQS PSM ADM

The PSM ADM is a compact switched mode AC/DC power supply module with multiple outputs. The input cable connects directly to the line output socket at the rear side of the chassis. The dc-outputs connect to an UT0 connector with 12 dc pins on the front panel.

The supply status is indicated with LED's on the front panel.

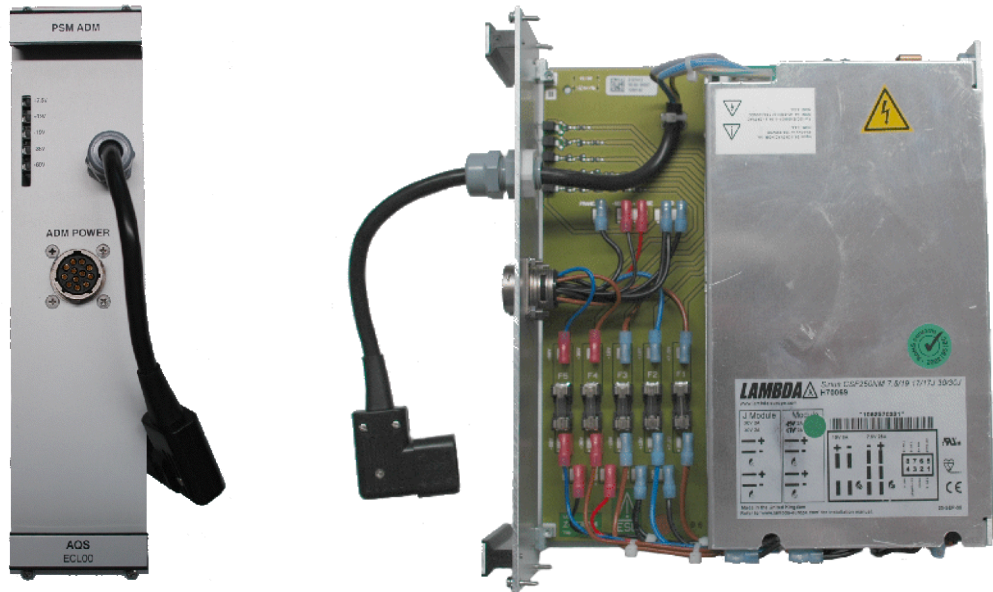

Figure 9.10 View PSM ADM

Supply	Fuse	Mat. Nb.	Value
+7.5V	F1	1801424	10 AT
+19V	F2	1801716	2.0 AT
-19V	F3	1802112	1.0 AT
-36V	F4	1802112	1.0 AT
-60V	F5	1802112	1.0 AT

Table 9.11 Fuses PSM ADM

Pin	Signal	Pin	Signal	Pin	Signal	Pin	Signal
A	GND	D	P7V5	G	GND	K	SHIELD (Earth)
B	GND	E	P19V	H	N36V	L	PSENSE_P7V5
C	P7V5	F	N19V	J	N60V	M	NSENSE_P7V5

Table 9.12 Pinout ADM POWER connector

## 9.10 AQS POWER SUPPLY BLA 28V 20A

---

The PS BLA is a compact switched mode AC/DC power supply module with a single 28V output. The ac-input cable connects to the line output socket at the rear side of the chassis. The dc-output connect to the backplane.

The supply status is indicated with LED's on the front panel.

The units has no serviceable parts or fuses.



Figure 9.11 View PS BLA 28V



# 10 AQS REF/3

## 10.1 Introduction

---

The AQS Reference Board 3, called „REF/3“, developed from 2009 to 2012, replaces the AQS Reference Boards for RXAD. A new phase synchronisation mechanism named „Synchro Reset“ has been implemented. The REF/3 is not backward compatible, requires SGU/3 and BSMS/2 Lock Transceiver and must be placed in slot 3 of an AQS rack.

One REF/3 can supply up to four SGU/3s, totalling eight TX channels. The not yet released REF/3-M is planned to double that number.

The heart of REF/3 still is a 10MHz OCXO (Oven Controlled Crystal Oscillator).

## 10.2 Description

---

All NMR frequencies and timings are generated by the REF/3 or derived from it. As there are:

- 10MHz signal for ELCB
- 20MHz clock for user backplane and IPSO
- 160MHz and 320MHz for BSMS/2 Lock Transceiver
- LO frequency (720MHz) for RXAD receiver
- Frequency mix for up to four (eight<sup>1</sup>) SGU/3
- „Synchro Reset“ to assure phase coherence of all NMR signals, even between different racks. Cable lengths are not absolutely critical anymore. This „Synchro Reset“ is a gap of 150ns length in the 960MHz signal on J6..J9 and can be triggered on the REF/3 by a SBSB command.

---

1. REF/3-M

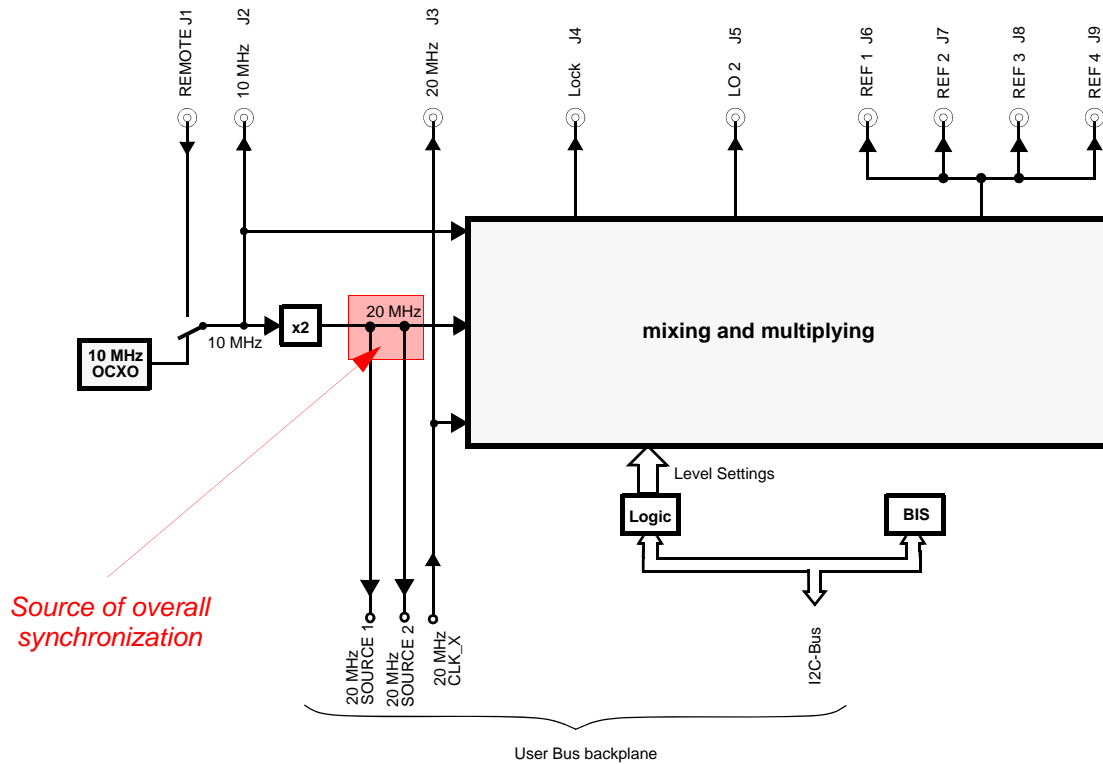

Figure 10.1 Block diagram of AQS Reference Board 3

### 10.2.1 Overall Synchronisation

The 20MHz signal generated by the first frequency doubler on the REF/3 is transmitted to the backplane as a differential ECL signal (20MHz\_SOURCE1 and 2). This signal is refreshed on the backplane and distributed to all the slots of the user bus (signals 20MHz\_CLK\_X and 20MHz\_CLK\_X). The REF/3 picks its own 20MHz clock from the backplane again and provides the IPSO with it (SMA connector J3). All clock frequencies in both the analog and digital sections of the AQS are synchronized with the 20MHz clock of the REF/3.

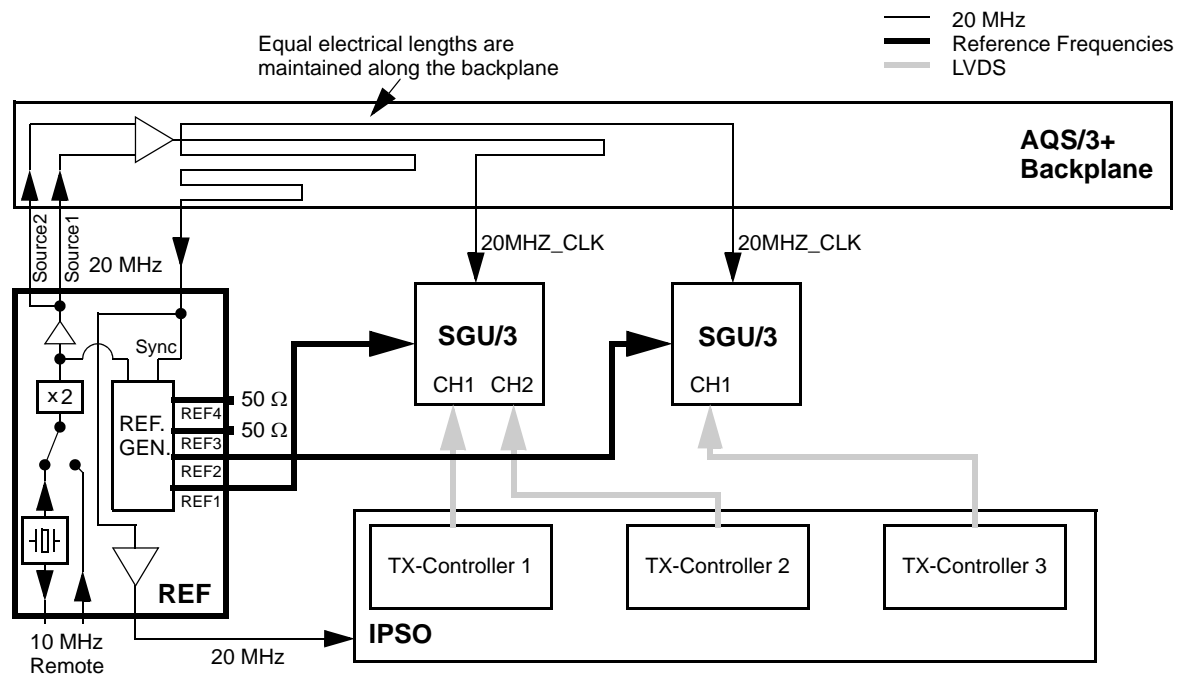

Figure 10.2 Overall synchronisation of a 3 channel spectrometer with an AQS/3+ chassis

### 10.2.2 Cable Lengths

Due to the new Synchro Reset phase coherence mechanism, equal cable lengths are not required anymore. However, cables should always be as short as possible to minimize insertion loss.

### 10.2.3 Bus Interfaces

The AQS Reference Board is controlled by the I<sup>2</sup>C bus on the backplane. This bus is used to:

- read BIS date (Bruker Information System)
- allow the AQS controller (DRU in slot 1) to set frequency output power levels and ready LED and to read status of power supply voltage and SGU/3 output power level self diagnosis.

## 10.3 Unit Configuration / Jumpers

The unit is configured through the „cf“ routine. No jumper setting required.

### 10.3.1 Differences to Previous Version

Phase Noise performance has been improved, power supply voltage and SGU/3 output power level self diagnosis added.

There is a new phase synchronisation mechanism called „Synchro Reset“. New frequencies for SGU/3 are generated. REF/3 is neither backward compatible to SGU/2 or older nor to BSMS Lock Receiver/Transmitter.

### 10.4 Front Panel Wiring / Display

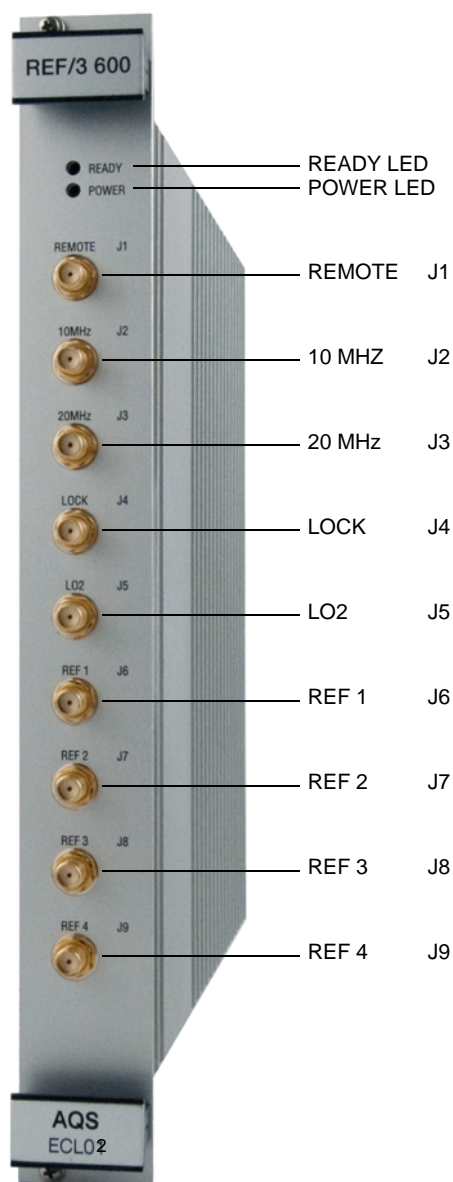

Figure 10.3 REF/3 front panel

**J1 REMOTE IN**

By applying a 10MHz sine wave clock signal of power 8dBm...14dBm to J1, the OCXO on the Reference Board is switched off and the applied 10MHz signal is used instead for frequency generation.

**J2 10MHz OUT**

+7dBm ( $1.4V_{pp}$  @  $50\Omega$ ) sine wave signal for ELCB

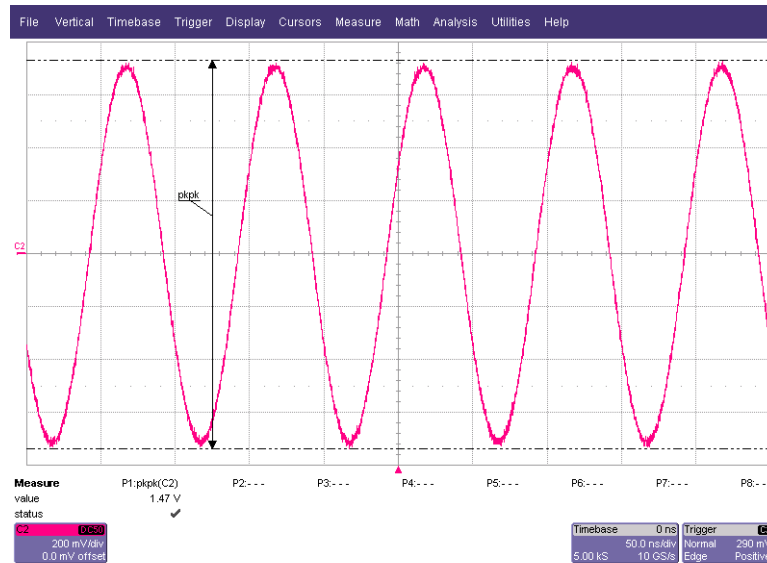

Figure 10.4 Waveform of signal at J2

**J3 20MHz OUT**

$0.9V_{pp}$  @  $50\Omega$  square wave signal (+5dBm @ 20MHz fundamental wave) for IPSO

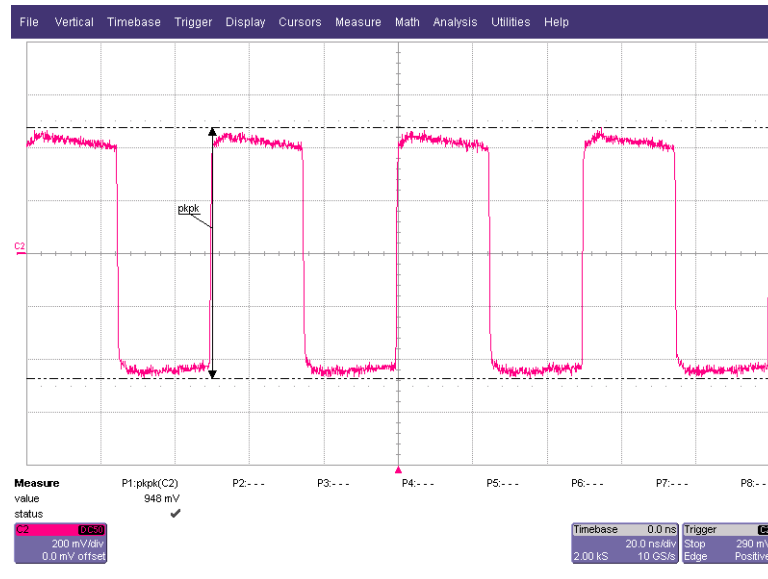

Figure 10.5 Waveform of signal at J3

### J4 LOCK OUT

Phase locked mix of two sine wave signals:  $-0.5\text{dBm}$  ( $0.6\text{V}_{\text{pp}}$  @  $50\Omega$ ) @  $160\text{MHz}$  and  $-3.5\text{dBm}$  ( $0.42\text{V}_{\text{pp}}$  @  $50\Omega$ ) @  $320\text{MHz}$

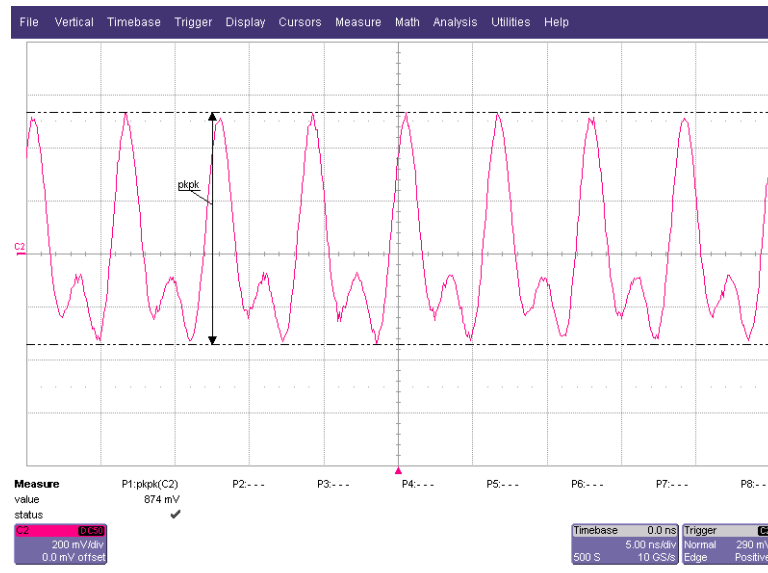

Figure 10.6 Waveform of signal at J4

### J5 LO2 OUT

$+4\text{dBm}$  ( $1\text{V}_{\text{pp}}$  @  $50\Omega$ ) sine wave signal @  $720\text{MHz}$

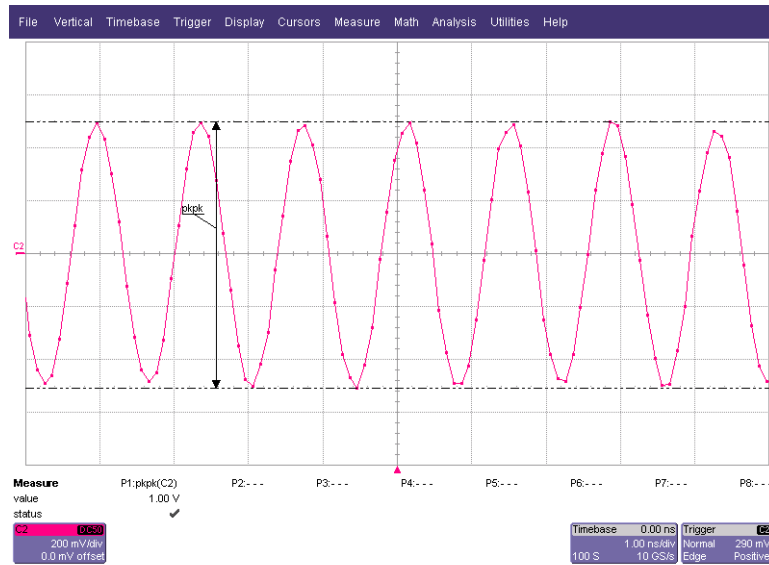

Figure 10.7 Waveform of signal at J5

### J6-J9 REF1-4 OUT

Phase locked mix of two tones: 960MHz and 1280MHz, power level -4dBm (0.4V<sub>pp</sub> @ 50Ω) each. New feature: Synchro Reset.

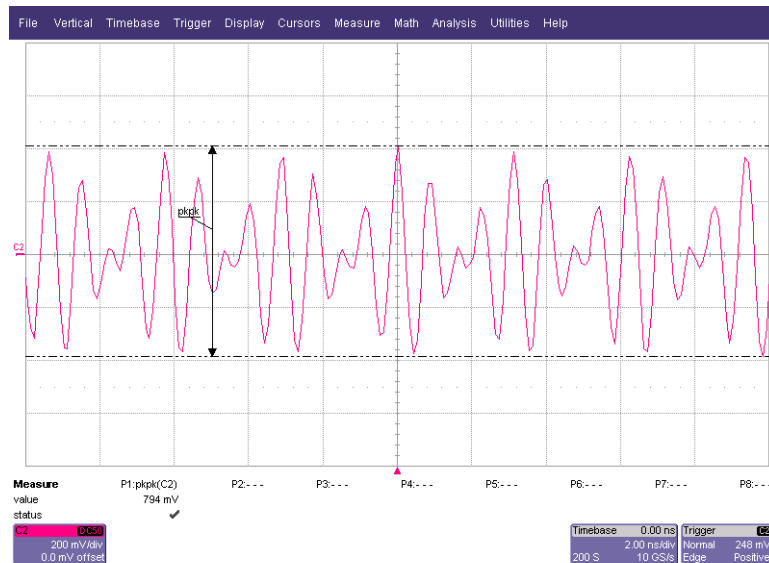

Figure 10.8 Waveform of signal at J6...J9

### LEDs

There are two LEDs. The ready LED is set by the AQS controller as soon as all signal output power levels are set to their appropriate value. The power LED is set as long as the power supply voltage self test is successful. This feature is hard wired. In case of power supply failure, the power LED switches off at once.

## 10.5 Part Numbers

---

AQS REERENCE BOARD/3 600: P/N Z116985

Not released yet:

AQS REERENCE BOARD/3 1200 : P/N Z126572

AQS REERENCE BOARD/3-M 1200: P/N Z126573

## 10.6 Troubleshooting / Unit replacement / Tips'n Tricks

---

- Unused REF outputs (J6-J9) have to be terminated by 50Ω resistors. Other outputs can be left open.
- If you suspect a broken OCXO, apply your own 10MHz sine wave signal to J1 („REMOTE“). Remote signal power level should be between +8dBm and +14dBm at 50Ω.
- The power supply voltage self diagnosis is hard wired. In case of power supply failure, the power LED switches off at once.

## 10.7 Specifications

---

Most important specification: Phase noise. Maximum values for REF/3 600, J6..J9, 1280MHz:

-75dBc @ 10Hz Offset

-95dBc @ 100Hz

-110dBc @ 1kHz

-120dBc @ 10kHz

Accuracy of output power levels: ±0.5dB

## 10.8 Power Supply

---

The Reference Board 3 uses only +9V and +19V from the backplane. See ["Backplane Connector REF/3" on page 113](#). The power LED on the front panel indicates that all voltages generated on the REF/3 from backplane +9V and +19V are present and at correct level.



### 10.8.1 Backplane Connector

The table below shows the pin assignment for the rear 110 pin connector. Note the presence of the source and clock signals.

	z	a	b	c	d	e	f
1	GND	GND	NC	NC	GND	NC	GND
2	GND	20MHz_SOURCE1	GND	NC	NC	NC	GND
3	GND	GND	20MHz_SOURCE2	I2C_STATUS_INT~	GND	NC	GND
4	GND	20MHZ_CLK_X	GND	NC	NC	NC	GND
5	GND	GND	20MHz_CLK_X-	NC	GND	NC	GND
6	GND	NC	GND	NC	NC	NC	GND
7	GND	NC	NC	NC	GND	NC	GND
8	GND	NC	GND	NC	NC	NC	GND
9	GND	NC	NC	NC	GND	NC	GND
10	GND	NC	GND	NC	NC	NC	GND
11	GND	NC	NC	NC	GND	NC	GND

#### Key Area

15	GND	SLOT2	SLOT1	SLOT0	GND	NC	GND
16	GND	NC	GND	I2C_SDA	NC	GND	GND
17	GND	NC	NC	I2C_SCL	GND	NC	GND
18	GND	NC	GND	NC	NC	GND	GND
19	GND	NC	NC	NC	GND	NC	GND
20	GND	NC	GND	NC	NC	GND	GND
21	GND	NC	NC	P9V	P9V	P9V	GND
22	GND	NC	NC	NC	NC	NC	GND
23	GND	NC	P19V	NC	NC	NC	GND
24	GND	NC	P19V	NC	NC	NC	GND
25	GND	NC	P19V	NC	NC	NC	GND

Table 10.1 Backplane Connector REF/3



# 11 AQS RXAD/2

## 11.1 Introduction

---

The AQS RXAD/2 is a high dynamic range receiver for NMR with integrated analog-to-digital converter (ADC). The AQS RXAD/2 is available for two different nuclei ranges (RXAD/2 600 and RXAD/2 1000). The AQS RXAD/2 is fully integrated in the AQS/3+ concept and runs in conjunction with the AQS SGU/3, AQS REF/3 and AQS DRU. The AQS RXAD/2 is located in the analog section of the AQS rack. The board is physically as long as the other AQS units and attaches to the user bus (backplane) directly.

As the name suggests the AQS RXAD/2 receiver is a further derivative of the AQS RXAD. The RXAD/2 unit has an enhanced dynamic range at low RG's and includes the broadband ability of the former AQS RXAD-BB (no special solids version anymore).

The AQS RXAD/2 has a sufficient gain range to be set in 1 dB steps. The correct setting of the RF gain will ensure that the receiver output is matched to the ADC range.

The entire receiver function is controlled by a microprocessor. This allows accurate gain setting, phase/amplitude and dc offset adjustment in the quadrature-module via a RS485-Interface which runs over the backplane. Calibration and production data (BIS, Bruker Board Information System) are stored in a EEPROM flash on the board.

A vital element of any RF receiver is the quality of the shielding to maximize the suppression of noise. In the design of this unit special attention has been paid to maximal clean signal transmission etc. The AQS RXAD/2 is mounted in a 19" RF cassette type case.

All communication with the AQS RXAD/2 take place using the SBSB1 link along the backplane. This enables the application of the UniTool which is a software diagnostic tool and is also used for accessing other devices like SGU/3 or HPPR/2.

The AQS RXAD/2 is also initialized and supervised by the AQS controller (AQS DRU) using the separate internal RS485 bus on the AQS User Bus.

In multi receiver systems each channel is equipped with a AQS RXAD/2 and DRU and its SGU/3 channel for LO (local oscillator) signal generation.

## 11.2 Functions/Description

---

The AQS RXAD/2 has four main functions, which are to amplify the signal from HPPR, to down convert it, to match the input range of the ADC and digitize the quadrature signal. The vital elements of this are the linear amplification of all frequencies as well as to guarantee the precise phase relationship of all RF signals.

The RF input is amplified in several stages to increase the dynamic range. The current LO frequency for the first mixer stage is generated in the LO frequency synthesizer.

At the final section the IF signal is split into two channels with phase difference of 90 degrees, a standard method well known as the classical quadrature detection. In order to ensure that the two channels provide identical amplification, slight adjustment to the phase and gain of these channels may be necessary. This can be done via UniTool. Channel A and B are connected directly to the integrated ADC.

The integrated ADC converts the quadrature signal at a very high sampling rate and transmits the data to the AQS DRU over a high speed data link on the backplane.

DC offset is pre-adjusted for proper control of the ADC input range and can be fine-adjusted using UniTool. The adjusted values can be saved in the on-board non-volatile memory.

In addition, the well known DQD-mode allows down-converting without quadrature and DC-signals.

During acquisition full control of the RXAD/2 sections (gain, frequency, sampling etc.) is maintained by two complex FPGA (field programmable gate array) that handles the real-time behavior. The FPGA real-time circuitry is controlled by external gating and pulse signals from the backplane (AQS/2 User Bus). Control information is passed on from the IPSO and the actual Observe-SGU in order to the channel concept.

The on-board microcontroller is used for initialization and RS485 communication.

For multi receiver systems with several preamplifiers, the gating pulse for the HPPR (RGP\_HPPR~) from the backplane is buffered and is fed separately to the front panel of the AQS RXAD (RGP\_HPPR~\_OUT J4).

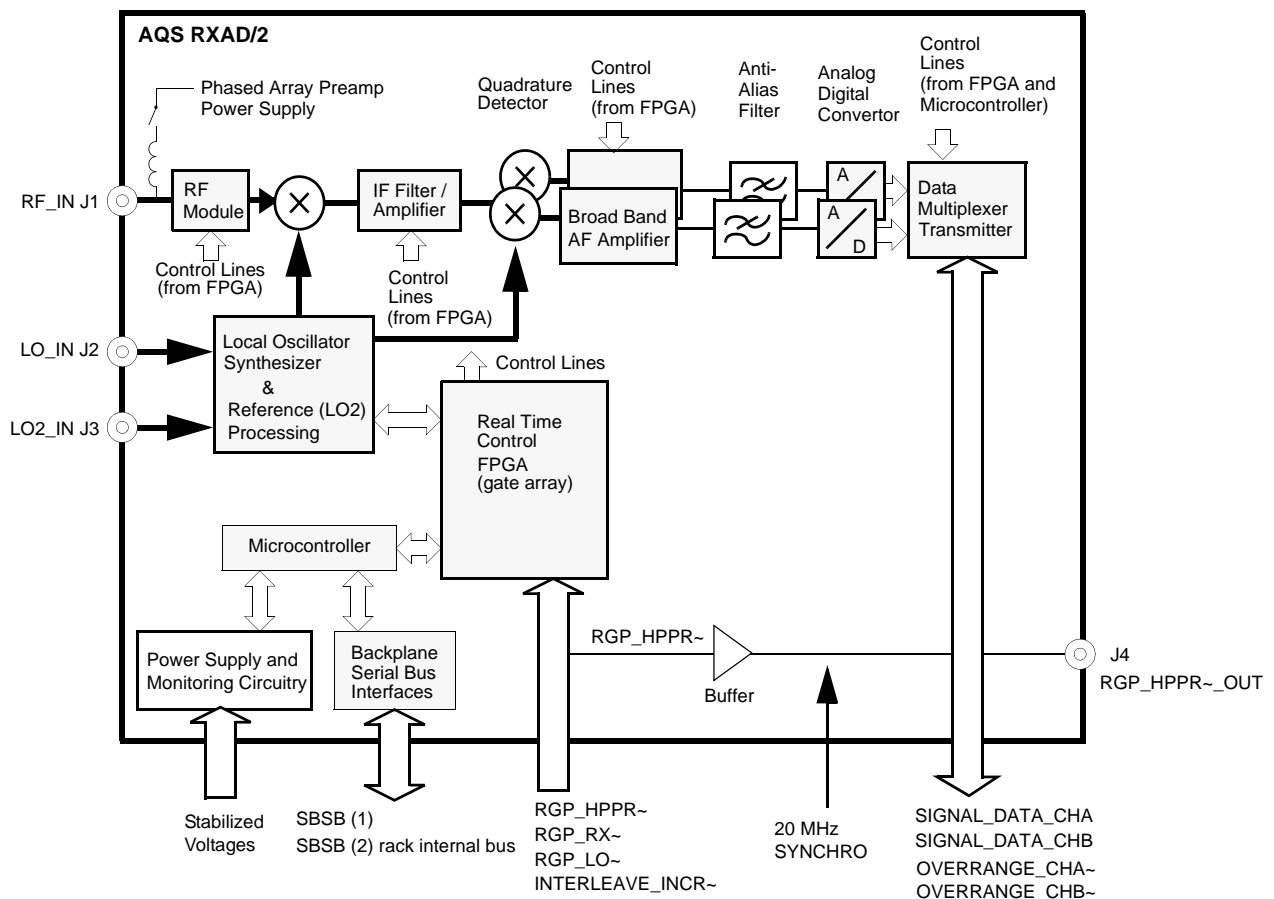

Figure 11.1 RXAD/2 Block diagram

### 11.2.1 Power Supply and Monitoring

---

All voltages supplied from the backplane are filtered and stabilized on the RXAD/2. Operation of the on-board power stabilization is monitored and indicated by the green LED on the front labeled POWER. If one of the AQS power supply voltages used by the AQS RXAD/2 fails the monitoring circuit will turn the LED off.

### 11.2.2 Reset

---

The AQS RXAD/2 controller is normally in sleep mode (reset state) to prevent disturbance and spikes in the spectra. The 20 MHz microprocessor clocking frequency is also switched off. The controller will be restarted each time a communication via the RS485 is opened (TOPSPIN or UniTool).

The controller will be active during acquisition only in the following cases:

- ,gs<sup>i</sup>-mode operation (which is typically used to adjust parameters dynamically) and
- at the beginning of wobble and receiver gain adjustment (rga)

This state is indicated by a blinking red LED labeled ERROR while the green LED labeled READY remains on.

### 11.2.3 Real Time Pulses

---

The AQS RXAD/2 is mainly controlled from the backplane by the following pulses

- RGP\_LO~
- RGP\_RX~
- INTERLEAVE\_INCR~

#### RGP\_LO~

The RGP\_LO~ pulse indicates that the LO signal from the SGU/3 is available and so the LO synthesizer of the AQS RXAD/2 can synchronize. If there is a RGP\_LO~ pulse and no appropriate LO signal (defective cable, not connected, wrong setting of SGU/3) an error message will appear.

#### RGP\_RX~

The RGP\_RX~ pulse opens the receiver after excitation and prevents saturation of the input stage while transmitters are switched on. An RGP\_RX~ pulse occurrence while the on-board microcontroller is running will also lead to an error message (except in ,gs<sup>i</sup>-mode operation) because microcontroller circuitry noise might affect the spectral purity of the RF signals.

#### INTERLEAVE\_INCR~

The receiver is prepared for pre-loading a table of different frequency/gain pairs. An

INTERLEAVE\_INCR~ pulse selects the next line of the table.

This concept is used for wobble, interleaved acquisition experiments and fast receiver gain ('rg') switching.

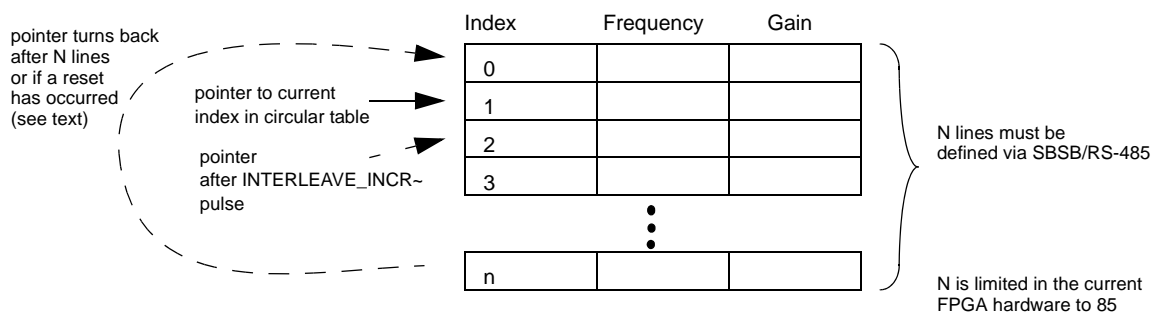

Figure 11.2 Circular Table: Mode of operation

The pointer in the circular table resets to index 0 if a long ( $\geq 4 \mu\text{s}$ ) INTERLEAVE\_INCR~ pulse has occurred. A short pulse ( $\leq 1 \mu\text{s}$ ) selects the next line of the table.

11.2.4 Effective Gain of the AQS RXAD/2

Receiver Gain 'RG'	Equivalent RX-BB/RX-22 Voltage Gain [dB] $20 \cdot \log([VHR\_OU / T / VRF\_IN])$	Receiver Gain 'RG'	Equivalent RX-BB/RX-22 Voltage Gain [dB] $20 \cdot \log([VHR\_OU / T / VRF\_IN])$	Receiver Gain 'RG'	Equivalent RX-BB/RX-22 Voltage Gain [dB] $20 \cdot \log([VHR\_OU / T / VRF\_IN])$
2050	78	90.5	51	4.50	25
1820	77	80.6	50	4.00	24
1620	76	71.8	49	3.56	23
1440	75	64.0	48	3.20	22
1290	74	57.0	47	2.80	21
1150	73	50.8	46	2.56	20
1030	72	45.2	45	2.25	19
912	71	40.3	44	2.00	18
812	70	36.0	43	1.78	17
724	69	32.0	42	1.60	16
645	68	28.5	41	1.40	15
575	67	25.4	40	1.28	14
512	66	22.6	39	1.12	13
456	65	20.2	38	1.00	12
406	64	18.0	37	0.89	11
362	63	16.0	36	0.80	10
322	62	14.2	35	0.70	9
287	61	12.7	34	0.64	8
256	60	11.3	33	0.56	7
228	59	10.0	32	0.50	6
203	58	9.00	31	0.44	5
181	57	8.00	30	0.40	4
161	56	7.12	29	0.35	3
144	55	6.35	28	0.32	2
128	54	5.60	27	0.28	1
114	53	5.00	26	0.25	0
101	52				

see footnote a

Table 11.1 Possible gain steps of the AQS RXAD/2

a. Maximum receiver gain value can be set by UniTool or WebTool to either RG 203 (default) or optional to RG 2050.

## 11.3 Unit Configuration / Version / Jumpers

---

There are two versions of RXAD/2 available (see ["Part Numbers" on page 124](#)).

Key specifications and digital control behavior remain the same for both versions.

There are no jumpers or manual switches to set.

Through the 'cf' routine the number and location of all installed RXAD/2s is determined. In multi receiver systems each RXAD/2 in the AQS/3+ chassis has a unique address derived from its physical position.

### 11.3.1 Differences to Previous Receiver Versions

---

The AQS RXAD/2 is different from the AQS RXAD in many ways:

- very low dead-time to switch on receiving
- improved dynamic range at low RGs
- broadband suitability



## 11.4 Front Panel Wiring / Display

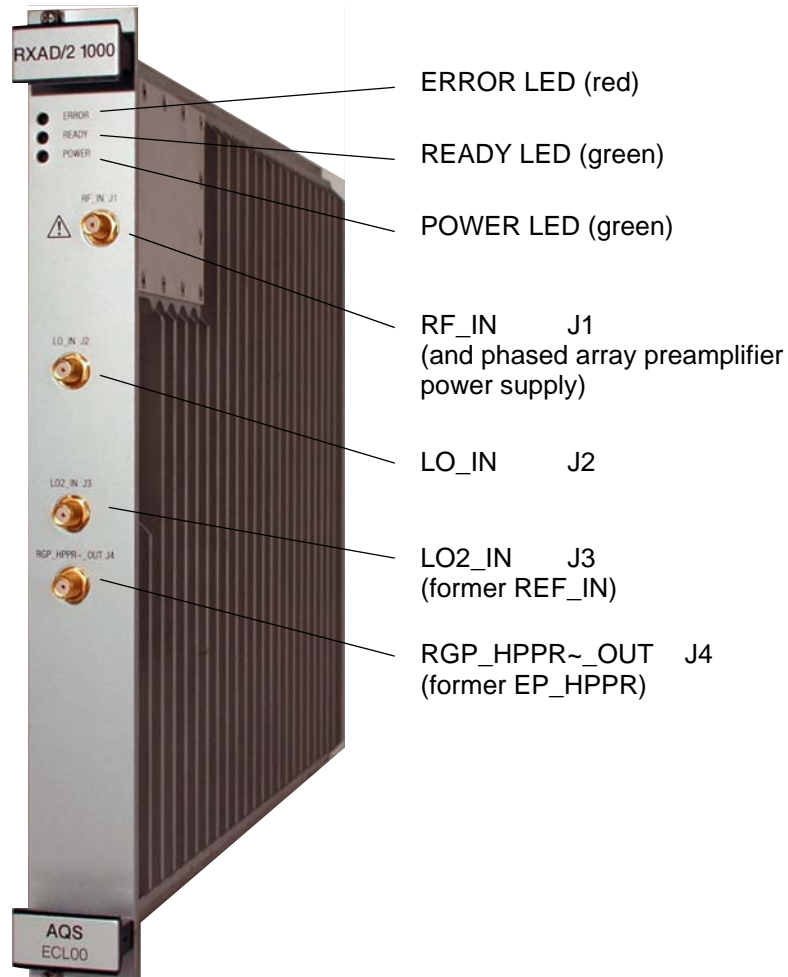

Figure 11.3 AQS RXAD/2 front panel

## 11.4.1 LED Display

The table below summarizes the states of the three front panel LEDs.



















ERROR (red)	READY (green)	POWER <sup>a</sup> (green)	Description
-	-	off 	- Power supply switched off or operating incorrectly
off 	on 	on 	- <b>Normal sleep mode</b> - Microcontroller asleep (no spectral spikes due to microcontroller circuitry) - No communication is possible with the RXAD/2.
off 	on resp. short-time flickering 	on 	- Ready for operation (microcontroller awake) - Communication with the RXAD/2 is possible.
off 	blinking (data stream) 	on 	- Communication LED The unit has received a command from the RS485 bus master. The READY LED switches off and as soon as the RXAD/2 acknowledges the command the READY LED is switched on again.
blinking slowly (approx. 3 Hz) 	on 	on 	- Indicates warning and not error ('gs' mode). Caution: Sensitive NMR experiments are not possible in this mode due to disturbances of the controller system.
blinking slowly (approx. 3 Hz) 	off 	on 	- An error has occurred on the RXAD/2
blinking fast 	-	on 	- Boot-mode Board not initialized yet or no application firmware found (e.g. because of power failure during firmware update).

Table 11.2 LED States

a. The power LED indicates that all necessary voltages are present and at the correct level. If any voltage level drops then the LED will go out. Thus once the power LED lights, further investigations on the backplane to check the precise voltage are unnecessary.

## 11.4.2 Front Panel Connectors

---

### J1 RF\_IN

Input (receive signal) from HPPR. This is a RF signal which will only be present when the HPPR is in receive mode. The timing is controlled by the RGP\_HPPR signal which is closely linked to the AQS RXAD/2 gating signal (RGP\_RX~). The phased array preamp power supply voltage is set to 10 V<sub>DC</sub> to meet the requirements of the MRI phased array preamps. The preamp power supply is by default turned off and can be enabled by software.

### J2 LO\_IN

RF CW signal with frequency of SFO1 + f<sub>DQD</sub> from SGU/3. This signal (1V<sub>pp</sub> at 50 Ω) originates from the observing SGU/3 (LO generating SGU/3) and is only present when the RXAD/2 is receiving.

The LO signal is routed in a chain through all SGUs and is fed from the most right SGU/3 (connector LO OUT J4) to the RXAD/2 – see also wiring principle.

### J3 LO2\_IN

Detector reference frequency (local oscillator signal 2) from AQS Reference Board (REF/3) LO2 J5.

### J4 RGP\_HPPR~\_OUT

Buffered gating pulse (RGP\_HPPR~) from backplane, used for preamplifiers in multi receiver systems.

## 11.5 Part Numbers

---

- Z130588 RXAD/2 600 (broadband option, 5...432.5 MHz)
- Z130589 RXAD/2 1000 (broadband option, 5...1072.5 MHz)

## 11.6 Troubleshooting / Unit Replacement / Tips 'n' Tricks

---

### 11.6.1 General

---

1. Do not open the AQS RXAD/2 in the field (calibration void).
2. Ensure that the AQS Reference Board is one of „REF/3 600“, „REF/3 1200“ or „REF/3-M 1200“ type.
3. To replace the unit simply switch off the AQS/3+ chassis, replace the board and switch the chassis on. Having inserted a new AQS RXAD/2 the spectrometer should be reconfigured ('cf') and the entry in the file `uxmnr.info` checked.
4. RF signals are all AC coupled<sup>1</sup> and the overall input resp. output impedance is 50 Ω. (Please note: The SMA-connector nuts must not be tightened more than to a torque of 45Ncm.)

### 11.6.2 Download new AQS Receiver (RX) Firmware

---

1. Check if the directory (`/Bruker/<topspin release>/conf/instr/servtool/UniTool/files/birds`) exists. Otherwise create it.
2. Copy the new firmware e.g. `rxs_aw.hex` into the directory `Bruker/<topspin release>/conf/instr/servtool/UniTool/files/birds`
3. Open a shell or the command prompt in the BRUKER Utilities folder when using Windows.
4. Start the UniTool: `topspin -e UniTool`
5. `-> aqs, confirm`
6. `-> decimal address for RX-1 is 16, confirm`
7. When the UniTool Menu is loaded, enter `<4> Auto Download -> download` is started. The download takes about 22 minutes
8. If you have more than one RX, do the same as above with address `17, 18, and so on`.

---

1. Except RF\_IN (J1) → see "[J1 RF\\_IN](#)" on page 123

### 11.6.1 Error Messages

Description of possible error messages:

Error No.	Error Message	Description	Possible cause
Error No. 1	Serial RS485 time-out	slave device did not answer in expected time	slave device probably not initialized, check connections
Error No. 4	Serial RS485 command, checksum error	RS485 protocol violation	spectrometer control software failure
Error No. 8	checksum error on INTRA bus		
Error No. 10	RAM Selftest Error	RAM test failed	hardware failure
Error No. 11	No application firmware found	no application firmware found	hardware failure or firmware download failed
<b>Error No. 13</b>	<b>Power failed</b>	<b>indicate that a power up has occurred and the system is not initialized</b>	<b>ordinary power up or a power breakdown during an experiment</b>
Error No. 15	Parameter exceeds valid range	value out of range	spectrometer control software failure or faulty input using Unitool
<b>Error No. 16</b>	<b>Unknown board hardware version</b>	<b>this hardware version has never been delivered</b>	<b>firmware or hardware error on RXAD/2</b>
Error No. 17	Function not supported by board hardware version		RXAD/2 with newer ECL required
Error No. 18	Unknown version index in configuration page	internal validation of calibration data failed	hardware error
Error No. 19	BIS checksum error		
Error No. 20	Syntax error	selected feature not supported by actual firmware, board does not understand command	spectrometer control software failure, wrong board selected, hardware feature not supported by actual version
Error No. 21	Command not available for this HW version		RXAD/2 with newer ECL required
Error No. 22	RTX create error	operating system error	firmware or hardware error on RXAD/2
Error No. 23	RTX memory allocation error		
Error No. 24	RTX memory free error		
Error No. 25	RTX communication pool exhausted		
Error No. 26	RTX send signal error		
Error No. 27	RTX interrupt handling error		
Error No. 28	RTX semaphore waiting list full		
Error No. 29	RTX pool create error		
Error No. 35	Download done correctly, but board not initialized, restart AQS when downloading has finished		

Table 11.3 AQS RXAD error messages (Release AR)

Error No.	Error Message	Description	Possible cause
Error No. 36	Flash Byte Program Error	failure during FLASH memory programming	hardware error
Error No. 37	Flash Erase Error		
Error No. 40	Flash Erase Timer expired		
Error No. 41	Error in Flash Command Sequence		
Error No. 42	Flash Page mismatch, storing terminated		
Error No. 43	calibration data invalid		
Error No. 50	RAM selftest error	RAM test failed	hardware failure
Error No. 51	no app firmware found (wrong FW checksum)	RAM test failed	hardware failure
Error No. 52	no app firmware found (wrong FW name)	RAM test failed	hardware failure
Error No. 53	no app firmware found (wrong FW id)	RAM test failed	hardware failure
Error No. 56	boot can't be forced to sleep, please download application firmware first		no application firmware is loaded
Error No. 57	Wrong filename, expected '.. rxs_ ...'		
Error No. 58	Corrupt BIS on board	BIS (Board Information System) test failed	hardware failure
Error No. 59	BIS checksum error	BIS (Board Information System) test failed	hardware failure
Error No. 60	Unknown rack code		
Error No. 61	Board Number exceeds valid range		
Error No. 100	Serial DAC bus (SPI, 8420) error		
Error No. 101	Serial ASIC bus (JTAG) error		
Error No. 102	Missing valid configuration page	configuration data (calibration data) not available	hardware failure
Error No. 105	Flash table does not exist, using default table	configuration data (calibration data) not available	hardware failure
Error No. 107	Table address or identifier out of range		
Error No. 128	input value out of range	entered input value out of range	spectrometer control software failure or faulty input using Unitool
Error No. 129	Error in LO generation (coarse tuning)	LO synthesizer was not able to set its frequency correctly	hardware failure
Error No. 130	Error in LO generation (VCO gradient fail)		
<b>Error No. 131</b>	<b>Error in LO generation (PLL lock lost)</b>	<b>LO synthesizer was not able to set its frequency correctly</b>	<b>LO IN cable from SGU/3 not connected REF IN cable from REF/3 not connected spectrometer control software failure</b>

Table 11.3 AQS RXAD error messages (Release AR)

Error No.	Error Message	Description	Possible cause
Error No. 133	Wrong RF-switch value	faulty input using Unitool	faulty input using Unitool
Error No. 134	Wrong IF-switch value		
Error No. 135	Wrong AF-switch value		
Error No. 136	Wrong PLL-gain-adjust value		
Error No. 137	Wrong PLL-level value		
Error No. 138	Enable/Disable expected		spectrometer control software failure or faulty input using Unitool
Error No. 139	No oscillator selected	faulty input using Unitool	faulty input using Unitool
<b>Error No. 140</b>	<b>Power Diagnostic failed</b>	<b>on-board diagnostic detected faulty power supply voltages</b>	<b>check power LED on AQS RXAD/2 and other AQS boards to determine if AQS RXAD/2 hardware failed or fuses on the power supplies need to be exchanged</b>
<b>Error No. 141</b>	<b>RGP_RX-Error occurred</b>	<b>receiver has been gated while the on-board microcontroller was running – spectra may show spikes</b>	<b>spectrometer control software failure</b>
Error No. 142	Frequency invalid		spectrometer control software failure or faulty input using Unitool
Error No. 143	Gain invalid		
Error No. 144	Gain distribution scheme not found		hardware failure
Error No. 145	Gain table not found		
Error No. 146	PLL table not found		
Error No. 147	VCO gradient too low		
Error No. 148	VCO gradient too high		
Error No. 149	I2C bus fail		
Error No. 150	wrong IF-gain-adjust value		
Error No. 151	wrong gain distribution table-index		faulty input using Unitool
Error No. 152	invalid row number in loop-table		spectrometer control software failure or faulty input using Unitool
Error No. 153	invalid amount of rows in loop table		
Error No. 154	Wrong PLL-tune value		faulty input using Unitool
Error No. 155	On/Off expected		spectrometer control software failure or faulty input using Unitool
Error No. 156	Frequency too high for this type of RX		
Error No. 157	DC offset correction table full, offset setting is stored temporarily only		too many entries in the dc offset correction table
Error No. 158	DC offset correction table can't be deleted - delete DC offset correction table in RAM then save config		faulty input using Unitool
Error No. 159	No ADC board available		
Error No. 160	Command not accepted while RF input is disabled, init RX/RXAD first		RF input was disabled via Disable-RF-Input-Command

Table 11.3 AQS RXAD error messages (Release AR)

## 11.7 Diagnostic Tests

The AQS RXAD/2 has no special written diagnostic program. The AQS RXAD/2 can be accessed with the UniTool that is accessible from BRUKER Utilities:

With UniTool you can

1. read and write the AQS RXAD/2 receiver gain
2. adjust the gain, phase and baseline for the quad module
3. adjust DC offset
4. measure the quad module temperature
5. read actual firmware version, ECL and hardware version
6. download new firmware

Be aware that UniTool is a hardware level tool and improper operation may void the calibration data. UniTool should be used by service personnel only.

## 11.8 DC Offset and Quadrature Correction Table

The DC offset of the AQS RXAD/2 variants running with TOPSPIN can be adjusted by software and stored in the on-board FLASH non-volatile memory. The offset values are handled for each frequency/gain pair and will automatically be adjusted each time the receiver gain (rg) or the observe frequency (the nucleus) is changed.

**i** NOTE: The frequency value in the correction table is rounded to the next 2.5 MHz index-step (see ). As a consequence of this rounding, a drifting magnet can cause a nucleus frequency to fall into another 2.5 MHz index-step where the RXAD/2 is not adjusted. In this case a readjustment is necessary. (This difficulty can occur in unlocked magnet systems only. In locked magnet systems the nucleus frequency does not drift away.)

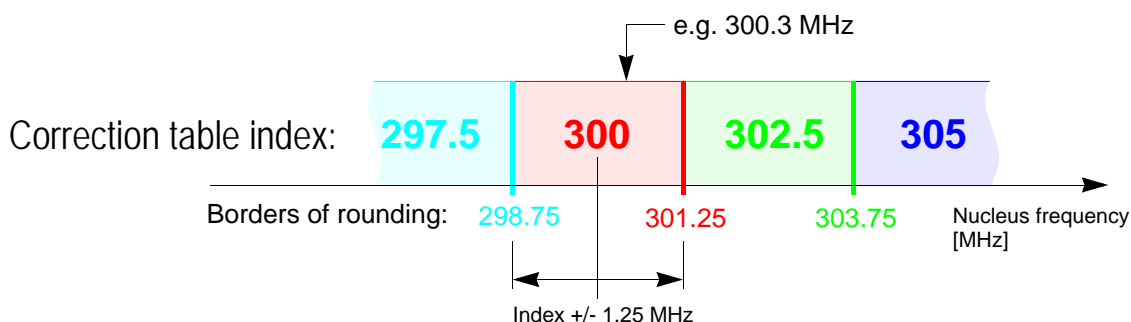

### 11.8.0.1 Rounding of the frequency in the Correction Table



If quad image gain/phase adjustment is necessary (initial quad image in qsim mode is factory pre-adjusted), do that before adjusting DC offset. See chapter 11.9 "Quadrature Phase/Gain Adjust – Useful Pulse Programs"

The following description was put together on the basis of TopSpin 2.n.



To fill a DC offset correction table you have to do a 'gs'-experiment with TOPSPIN. Be sure TOPSPIN has selected the nucleus/frequency you want to adjust the DC offset correction for.

---

**i** Install the following au program with 'expinstall' if necessary and run it (in TOPSPIN's command line):

---

**dccorr off**

After selecting an experiment choose TOPSPIN's acquisition window (Fid) to see the time domain signal and select Unsh (Unshuffle Symbol  or ) to see both channels.

Set the AQ\_mod (Acquisition mode) in the acquisition parameters (eda, AcquPars) to qsim.

Start your web browser (Internet Explorer, Mozilla Firefox, ...), type 'dru1' (respectively 149.236.99.89) into the URL field and hit <Enter>. Branch into --> 'Hosted Devices' --> 'AQS Overview' --> 'AQS RXAD/2 1'

Remember:

- 149.236.99.89 : DRU1
- 149.236.99.87 : DRU3
- 149.236.99.80 : DRU10
- 149.236.99.73 : DRU17
- 149.236.99.66 : DRU23

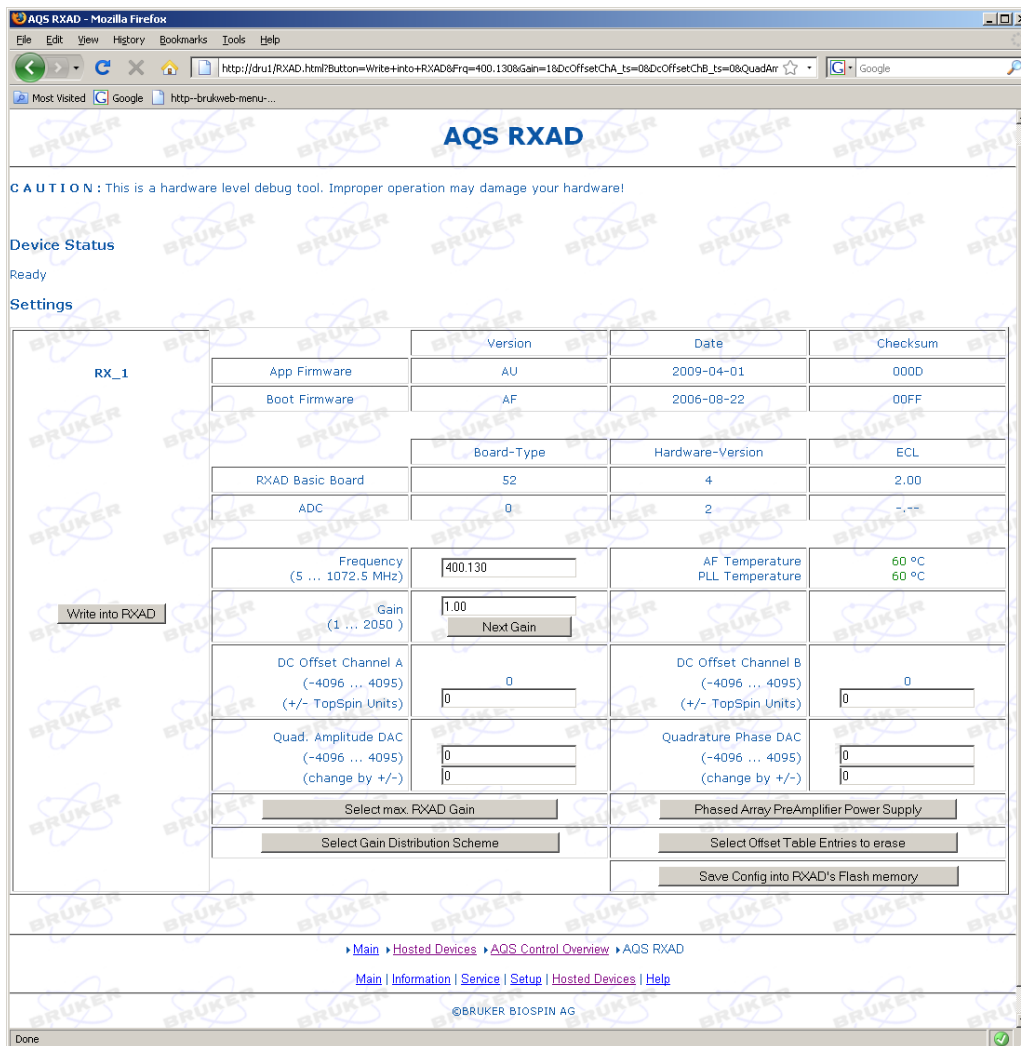

Figure 11.4 AQS RXAD/2 web page

The AQS rack must be powered on at least for 30 minutes to guarantee a stable temperature of the RXAD/2 before adjusting any quad image or DC offset.

You can check the RXAD/2-temperature (AF and PLL). The temperature values should be written in green color (not red). The nominal temperature is 54 °C or 59 °C dependant on the internal hardware-version.

The 'offset and quad image' table handles entries (max. 900 entries) which are stored according to the selected nucleus/frequency (in steps of 2.5 MHz) and the selected gain (in steps of 1 dB).

Before adjusting the table for the actual nucleus frequency you should check the frequency to be correct and erase all entries of the actual frequency. In the AQS RXAD/2 overview window branch into

--> 'Select Offset Table entries to erase' --> 'Erase all Entries of ACTUAL frequency' in the below picture --> 'Cancel', do not 'Save Config into RXAD/2's Flash' at this time.

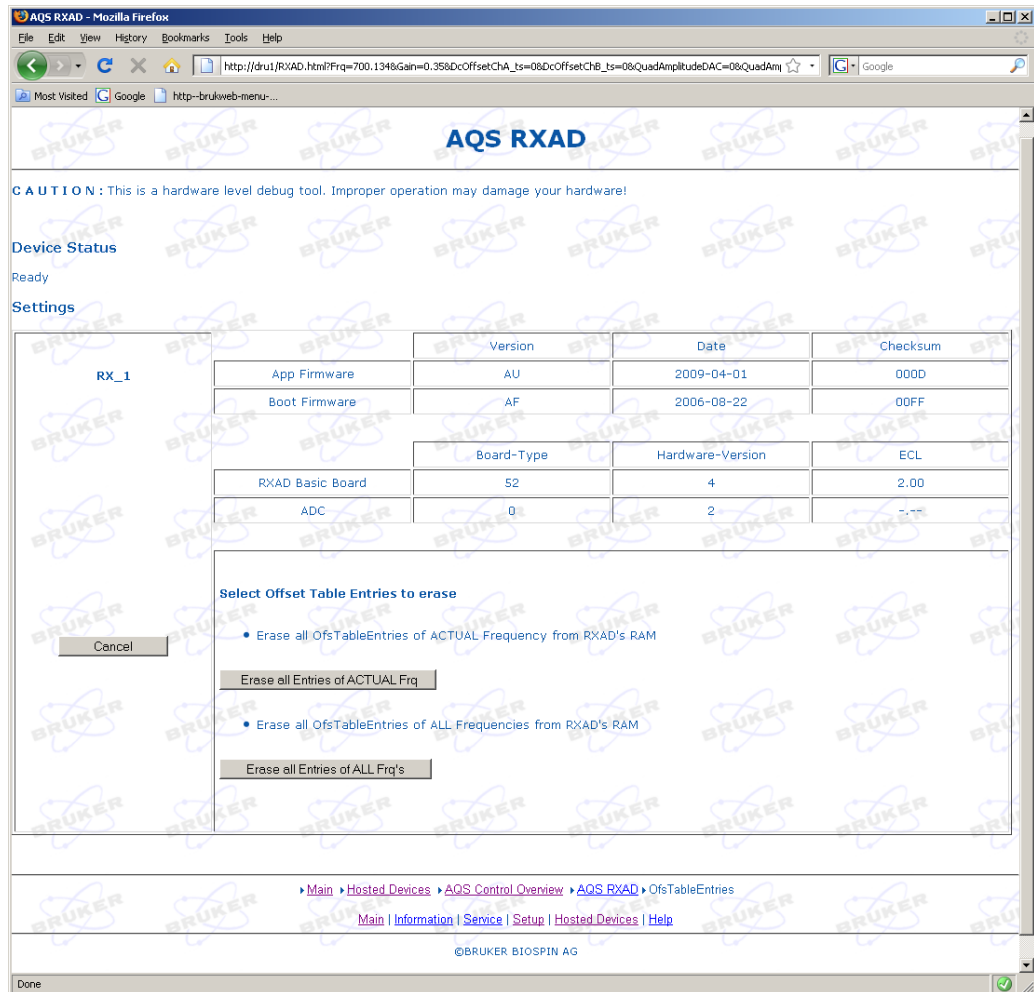

Figure 11.5 Erase all Entries of ACTUAL Frq

To adjust the table for the actual nucleus frequency you must start with the lowest gain. Check the frequency to be correct (press F5 to refresh/reload if necessary) then fill in '1' into the Gain input field and press the 'Write into RXAD/2'-button.

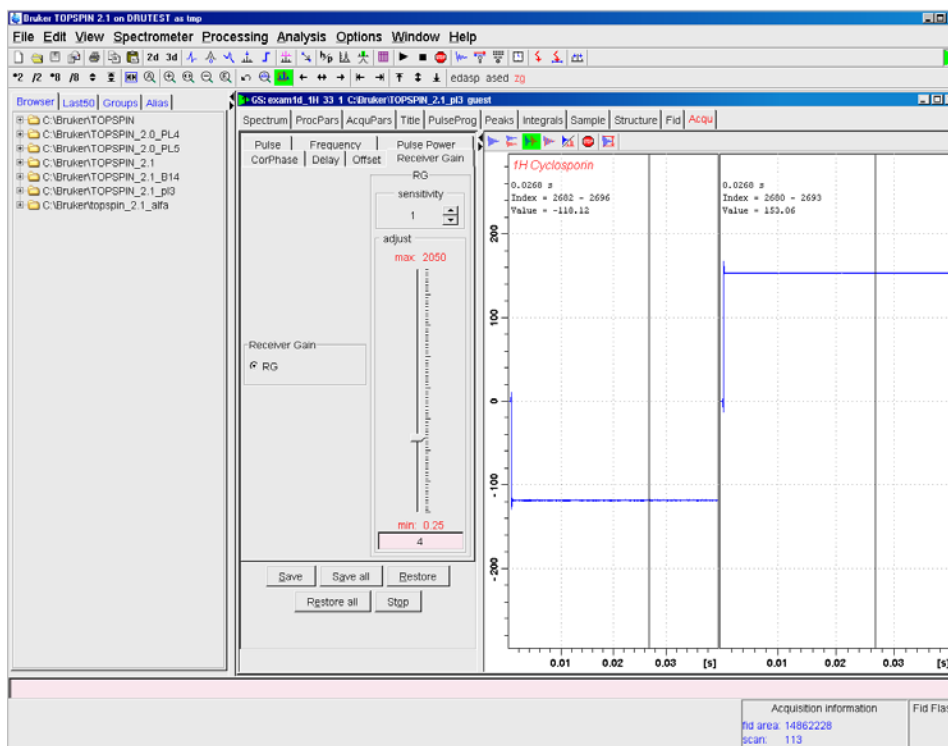

Figure 11.6 Example figure

The graph's above or left half of the TOPSPIN's y-axis shows the offset correction of channel A. If the graph's y-value is negative you have to enter that value positively to converge to zero offset. If the graph's y-value is positive enter the value negatively.

Fill in the 'DC Offset Channel A' input field (in this example 118) and press the button 'Write into RXAD/2'.

The controller on the RXAD/2 will calculate the internal correction values needed. Repeat this once or twice and you will be within one percent of the uncorrected offset.

**i** There may be an inaccuracy between entered value and actually set correction due to scaling variation by chosen digital filter and SWH.

The graph's below or right half of the TOPSPIN's y-axis shows you the offset correction of channel B. In this example fill in -153 into the 'DC Offset Channel B' input field and press the 'Write into RXAD/2'-button.

Repeat the whole procedure for the next gain by pressing the 'Next Gain'-button. Repeat 'Next Gain' until all gains are adjusted including the highest gain (= 203 respectively 2050).

If you don't want your table entries to be lost after a power down of the AQS-rack you need to save the RXAD/2 configuration by branching into --> 'Save Config into RXAD/2's Flash memory', confirm with --> 'Save Config into RXAD/2's Flash'. Confirming will take a few seconds.

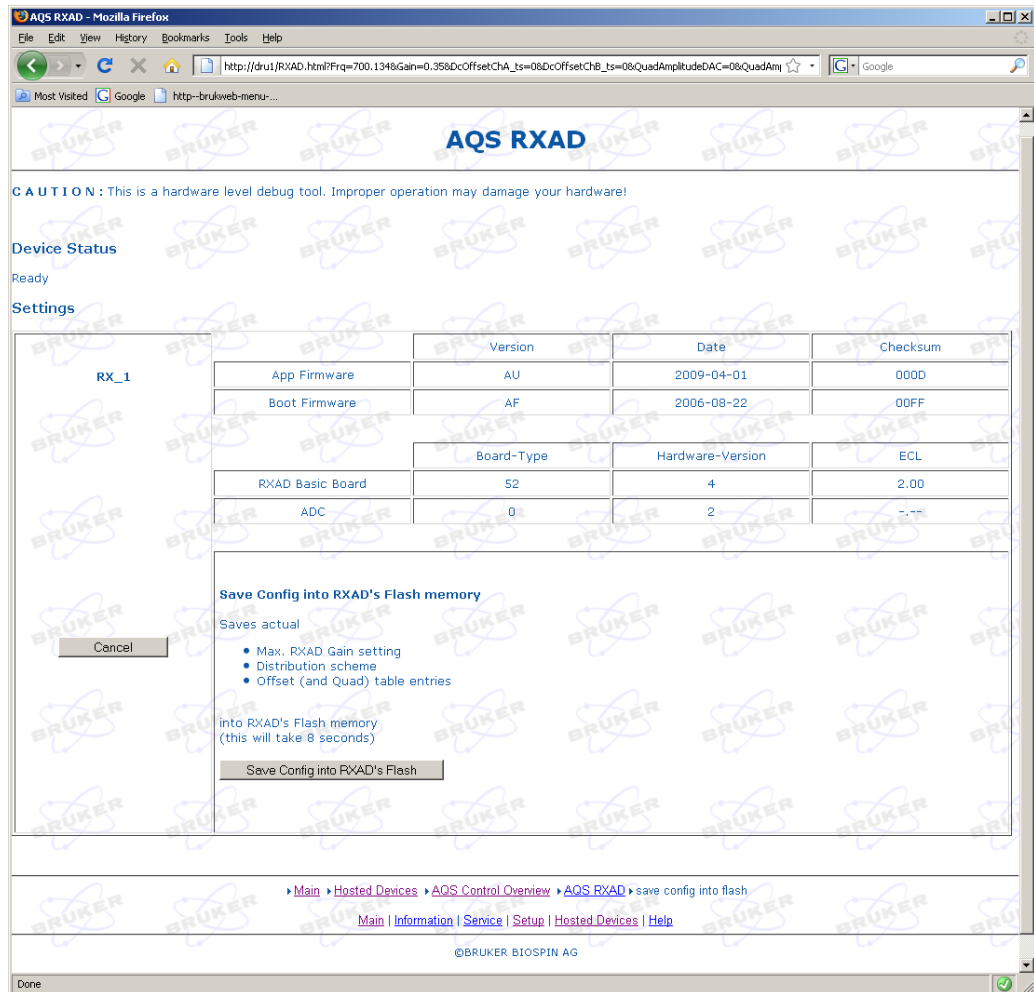

Figure 11.7 Save Config into RXAD/2 Flash

Stop the TOPSPIN experiment, select the next nucleus/frequency you want to adjust and start another 'gs'-experiment. Adjust in the same way as above...

**i** If you have finished DC offset correction run the following au program (in TOPSPIN command line):

```
dccorr on
```

Check and set the AQ\_mod as it was before the adjustment.

## 11.9 Quadrature Phase/Gain Adjust – Useful Pulse Programs

For quadrature phase/gain adjustment the following pulse program is useful:

```
;zgcw.mod
;avance-version (04/02/08)
;1D sequence with CW decoupling
```

```
#include <Avance.incl>
"d11=30m"
1 ze
2 d11 reset:f1 reset:f2
  d11 pl26:f2
  d11 cw:f2 ph30
  d1
  pl ph1
  go=2 ph31
  wr #0
  d11 do:f2
  exit
ph1=0 2 2 0 1 3 3 1
ph31=0 2 2 0 1 3 3 1
ph30=0
;pl1 : f1 channel - power level for pulse (default)
;pl26: f2 channel - power level for cw decoupling
;p1 : f1 channel - high power pulse
;d1 : relaxation delay; 1-5 * T1
;d11: delay for disk I/O [30 msec]
```

In edasp select two identical nucleus for F1 and F2 and set the offset frequency OFS2 of the second one to e.g. 1000.0 Hz

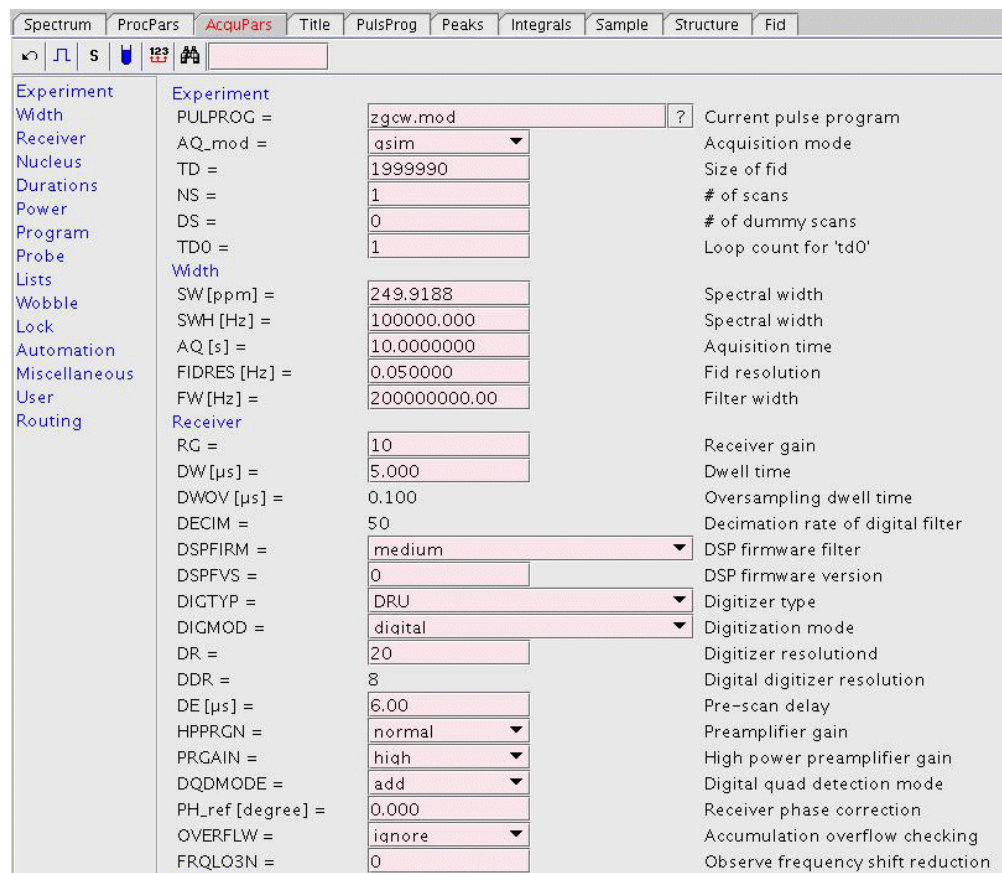

Figure 11.8 Example of eda for RXAD/2 Quadrature Adjustment

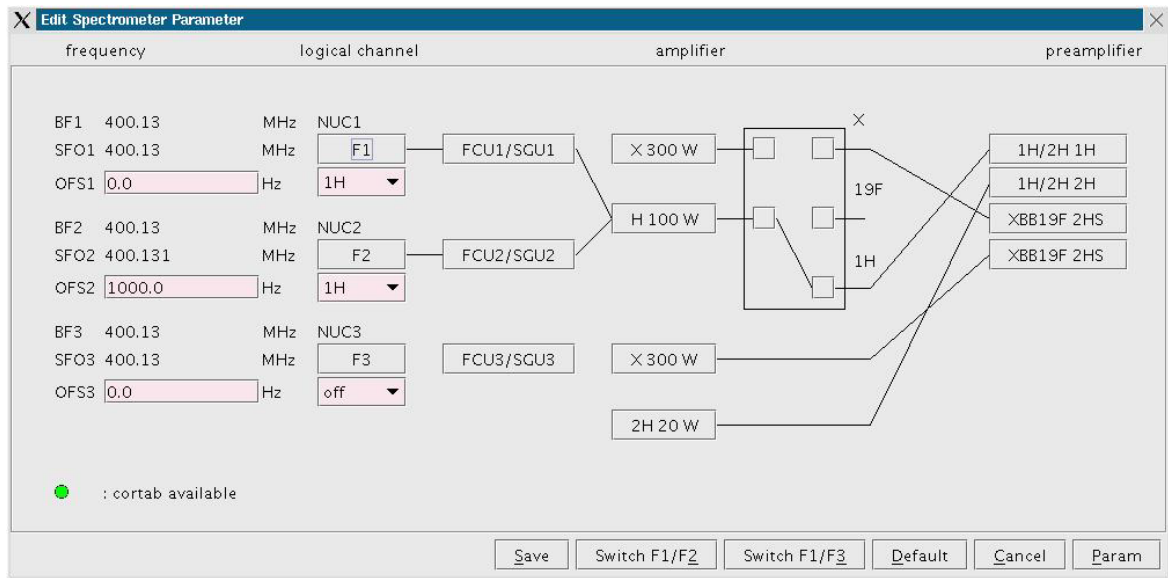



Figure 11.9 Proposed setup for quad image adjustment

Set phmod to mc.

Connect now the RF OUT of SGU/3 with the RF IN of the RXAD/2 directly and start acquisition in 'gs' mode (pl26 ≈ 40 dB).

Check the input signal level in the acquisition window. Check for appropriate amplitude of the ADC and do not overdrive it.

Press in TOPSPIN the button „Execute real-time ft and show spectrum“ (Symbol ) and adjust the quadrature image signal with the RXAD/2 web page.

The adjustment procedure is similar to that one for dc offset correction.

For phase/amplitude adjustments modify the 'Quad. Amplitude DAC' and/respectively the 'Quadrature Phase DAC' input field(s) and press the 'Write into RXAD/2' button.

## 11.10 Specifications

---

### Frequency Range:

RXAD/2 600	5...647.5	MHz
RXAD/2 1000	5...1072.5	MHz

### Frequency Stability:

This is governed by the stability of the crystal oscillator on the REF/3 unit

### Frequency Resolution:

The local oscillator synthesizer in the AQS RXAD/2 follows the SGU/3 LO signal.

<b>LO Phase Settling Time:</b>	max. 2	μs
<b>Audio Signal Settling Time:</b>	< 2	μs

### Gain:

Range: (linear 0.25...203)	0...58	dB
Resolution	1	dB

### ADC Resolution:

depends on oversampling rate on AQS DRU:

up to 200 kHz bandwidth	20	bit
up to 5 MHz bandwidth	16	bit

### ADC Output Data Rate:

28 bit / 20 Mwords per second	560	Mbit/s
-------------------------------	-----	--------



### 11.10.1 Timing Definitions

Turn on or settling time of the AQS RXAD/2 are defined as follows:

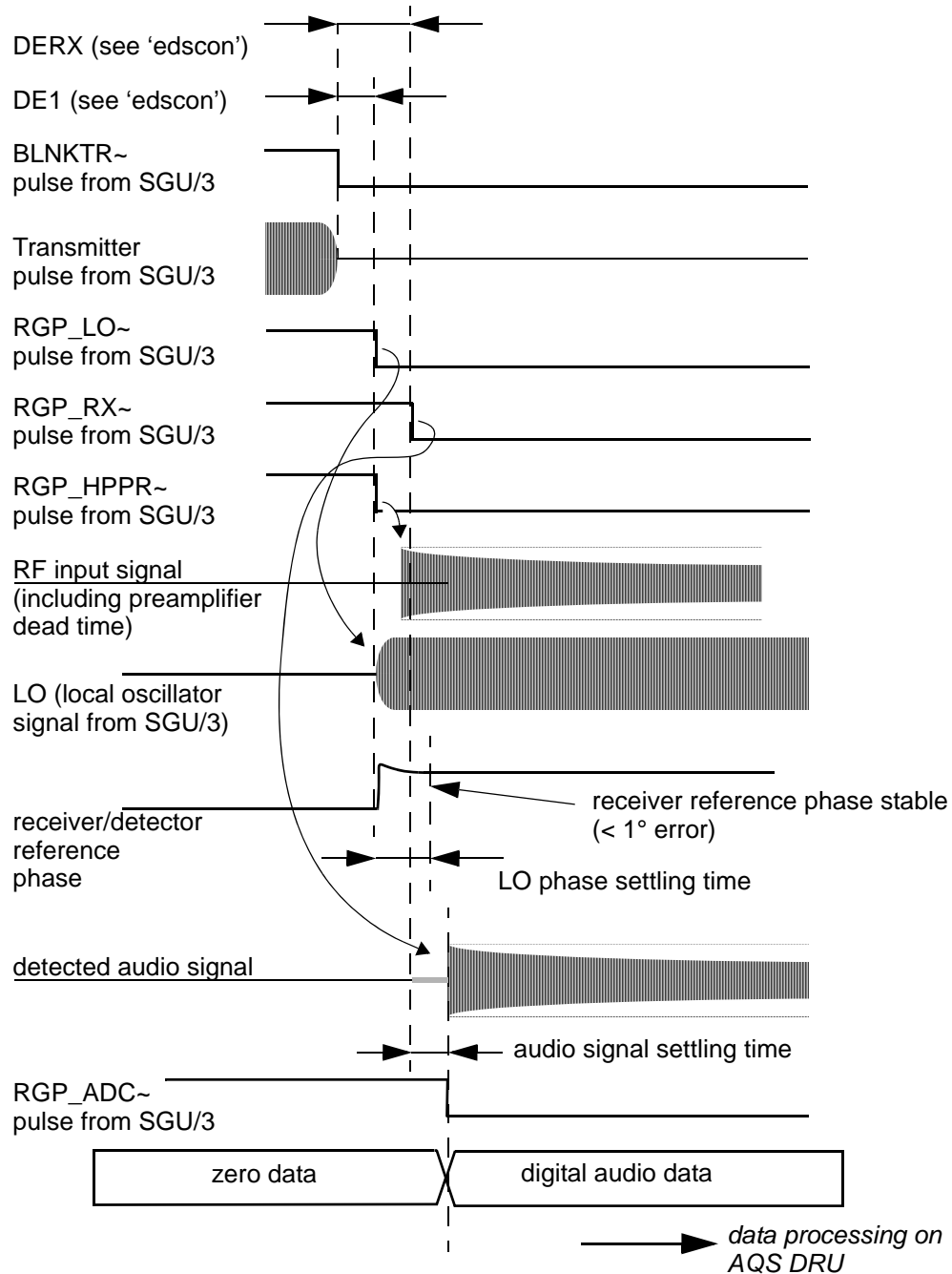

Figure 11.10 AQS RXAD/2 timing definitions

## 11.11 Power Supply / Fuses

See 11.4.1

### 11.11.1 Backplane Connector

	z	a	b	c	d	e	f
1	GND	GND	INTRA_STATUS-	NC	GND	NC	GND
2	GND	NC	GND	NC	NC	NC	GND
3	GND	GND	NC	NC	GND	NC	GND
4	GND	20MHZ_CLK_X	GND	INTERLEAVE_INCR-	NC	NC	GND
5	GND	GND	20MHz_CLK_X-	NC	GND	RGP_LO-	GND
6	GND	NC	GND	NC	NC	NC	GND
7	GND	NC	NC	NC	GND	NC	GND
8	GND	NC	GND	NC	NC	NC	GND
9	GND	NC	NC	NC	GND	RGP_RX-	GND
10	GND	SBS_TTL_TX	GND	SBS_TTL_RX	SBS_TTL_TX_ENAB-	NC	GND
11	GND	LOCAL_TX	LOCAL_RX	SBS_TTL_WUP-	GND	RGP_HPPR-	GND

#### Key Area

15	GND	SLOT2	SLOT1	SLOT0	GND	RESERVE_ADC_1	GND
16	GND	SLOT3	GND	NC	RESERVE_ADC_2	GND	GND
17	GND	NC	NC	NC	GND	ADC_I2C_SDA	GND
18	GND	NC	GND	NC	NC	GND	GND
19	GND	NC	NC	NC	GND	ADC_I2C_SCL	GND
20	GND	NC	GND	NC	NC	GND	GND
21	GND	P5V	P35V	P9V	P9V	P9V	GND
22	GND	P5V	RACK0	N9V	N9V	N9V	GND
23	GND	P5V	P19V	N19V	RACK1	P12V	GND
24	GND	P5V	P19V	N19V	RACK2	P12V	GND
25	GND	P5V	P19V	N19V	RACK3	P12V	GND

Table 11.4 RXAD/2 backplane connector

	z	a	b	c	d	e	f
1	GND	P5V	P5V	P5V	P5V	P5V	GND
2	GND	RESERVE_4	RESERVE_5	GND	RESERVE_3	GND	GND
3	GND	ADC_I2C_SDA	GND	L3_OPT	GND	LCLK_OPT	GND
4	GND	ADC_I2C_SCL	GND	L3_OPT~	GND	LCLK_OPT~	GND
5	GND	GND	L_CLK	GND	L_DATA_3	GND	GND
6	GND	GND	L_CLK~	GND	L_DATA_3~	GND	GND
7	GND	L_OVR0	GND	L_DATA_2	GND		GND
8	GND	L_OVR1	GND	L_DATA_2~	GND		GND
9	GND	GND	L_DATA_1	GND	L_DATA_0	GND	GND
10	GND	GND	L_DATA_1~	GND	L_DATA_0~	GND	GND
11	GND	RESERVE_0	GND	RESERVE_1	GND	RESERVE_2	GND

Table 11.5 RXAD/2 extension connector

## 11.12 RXAD/2 Accessory

---

### 11.12.1 MRI Array-Preamp Supply 10V

---

Do not use such a converter box with the RXAD/2 units. The RXAD/2 units already have the appropriate 10 V<sub>DC</sub> supply voltage built-in.

# 12 AQS DRU

## 12.1 Introduction

---

The AQS DRU (Digital Receiver Unit) is a digital signal processing board implementing an enhanced digital receiver in comparison to the RCU introduced in 1994. It incorporates the digital mixing (LO3) stage for DQD and the ,on the fly' digital signal processing block for a variety of digital filters within the AQS/3+ receiver system.

To achieve a more flexible spectrometer integration (especially with extended multiple receiver systems), accumulation and data buffering is done on board. This allows for data transfer to the workstation to run across a commercial local area network (Fast Ethernet LAN). The omnipresent transfer control protocol / internet protocol (TCP/IP) is used to build the loosely coupled, standardized spectrometer environment, thus allowing flexible extensions.

Distributed communication between the workstation and one or more DRU runs on common object remote broker architecture (CORBA). CORBA is a modern and reliable distributed object middle ware. By implementing a hardware- and operating system independent software interface, it allows to communicate with the DRU by any workstation topology (Intel architecture, SGI, etc.) and operating system (JAVA, .NET, etc.)

Diagnosis and servicing access to the DRU relies on hypertext transfer protocol (HTTP) and hypertext markup language (HTML), enabling service access just by any web browser (e.g. Mozilla Firefox), without the need for special training of service people like the former UniTool.

The AQS DRU includes interfaces for automatic tuning and matching (ATMA), probe identification and control system (PICS) and AQS integrated preamplifier modules.

The AQS DRU comes in three versions, the DRU, the DRU-E and the DRU-M:

### **AQS DRU, P/N Z100977**

The AQS DRU is an open frame PCB design and should be handled with care. A real-time pulse (RCP) input is used to switch the 2H preamplifier module transmit and receive switch according to the lock operation (TP\_F0).

From ECL 7 the AQS DRU allows to operate a Prodigy Cryo Probe with a Nanobay V3.

### **AQS DRU-E, P/N Z102520**

The AQS DRU-E is enclosed in an aluminum metal case allowing seamless integration in the AQS chassis - concerning minimized RF interference and design.

The AQS DRU-E from ECL 6 no longer contains the 28 bit very high speed interface which has never been used. This functionality has been replaced by an 48 bit interface on the DRU-M which feeds the R-Controller board of the IPSO.

From ECL 6 the DRU-E contains the same preamplifier and ATMA interfaces as the DRU and thus can be used as a direct replacement for the DRU.

## AQS DRU-M, P/N Z106185

The AQS DRU-M is enclosed in an aluminum metal case allowing seamless integration in the AQS chassis - concerning minimized RF interference and design. This version includes a very high speed interface to stream the received data to further signal processing systems for applications requiring more than the 50MBit/s, e.g. for real time decision capability or just for user oriented dedicated solutions.

The protocol has not been defined yet but may be fixed later by downloading new firmware. Such protocols could be CameraLink™ or similar.

This version does not include interfaces for ATMA, PICS or preamplifier modules. The HPPR/2 system is required for these purposes instead.

A real-time pulse (RCP) output is available to trigger future experiments upon acquiring NMR data (to be defined).

## 12.2 Functions/Description

---

The basic digital receiver concept of the DRU is designed to fulfill the following tasks:

1. Interface to different types of AD converters (for future)
2. Propagate a digitizer overflow condition
3. Capture digitizer peak values (i.e. used for receiver gain adjust)
4. Automatic DC offset calibration (used for AutoZeroCompensation)
5. Digital receiver phase control
6. Digital quadrature detection (LO3)
7. Digital filtering of NMR signals
8. Decimation of NMR signals
9. Accumulation and acquisition, multi buffer handling
10. Data transfer to workstation via ethernet (write to disk, online display)
11. Special fast functions (i.e wobble display, RGA, AutoZeroCompensation)
12. Integration of AQS preamplifier controller
13. Real Time Trigger output (RCP, for debugging)

Most of these operations (scan control) are under real time control by the pulse program via the so called ‚SampleInfo‘ bus. With this it is possible to handle the ADC data, in the extreme cases each sample, by the information given via this acquisition synchronous system bus. The scan control runs in parallel with the DWELL clock and the RGP\_ADC of the digitizer.

14. High Speed LVDS data output (DRU-M only)

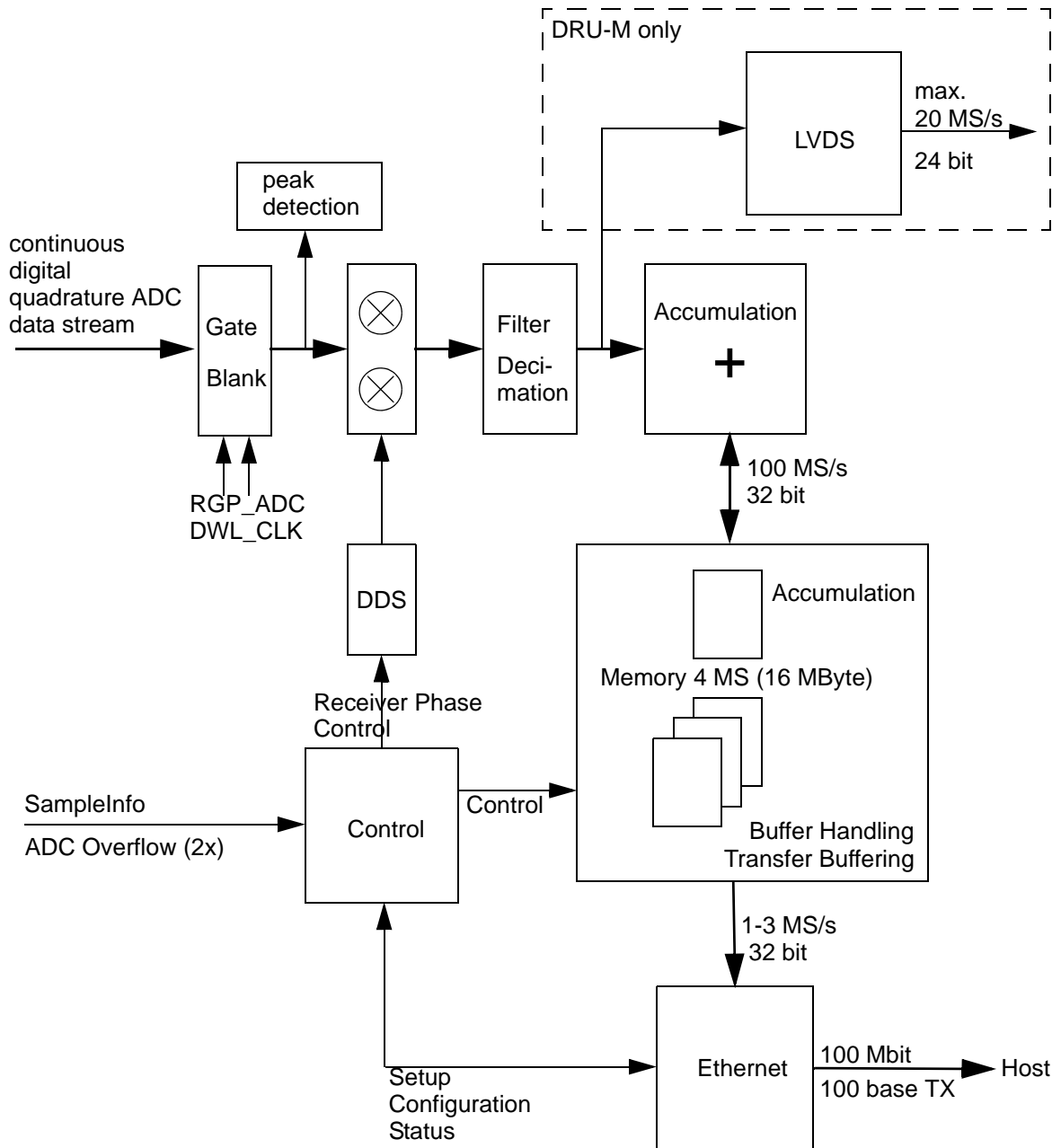

Figure 12.1 DRU Block diagram 'Digital Receiver'

## 12.2.1 Power Supply and Monitoring LEDs

Operation of the on-board power stabilization is monitored by the two green LED on the front labeled ,POWER‘.

The LED labeled ,DRU‘ monitors the internal DRU supplies (3.3V, 2.5V, 1.5V). These are all derived from a single 5V AQS backplane supply.

The LED labeled ,ATMA‘ monitors the +9V ATMA voltage which is connected to the HPPR\_9V AQS backplane supply.

## 12.2.2 Front Panel Wiring / Display

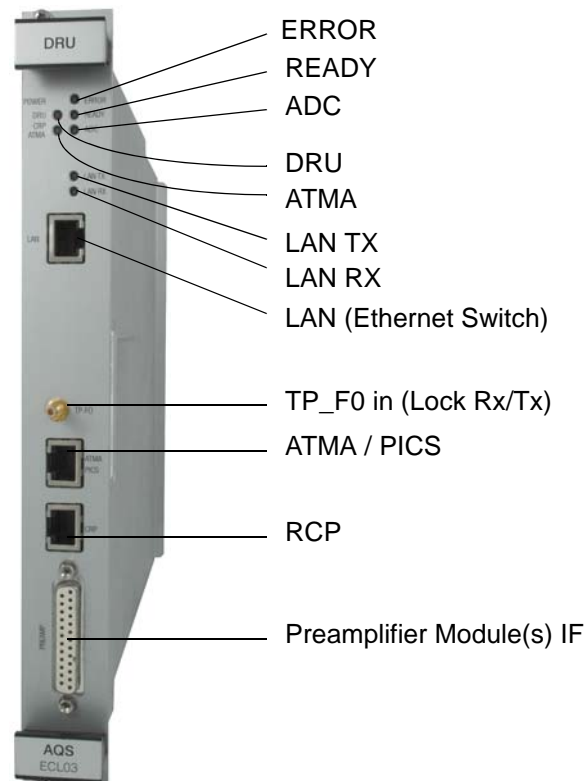

Figure 12.2 AQS DRU-E and AQS DRU front-side view

## 12.2.3 Reset and Operation LED Display

### ERROR LED

The red ,ERROR‘ LED indicates a pending ERROR.



**READY LED**

Normal operation is indicated by the green ,READY' LED.

Every 500ms this LED is turned off for 20ms, resulting in a faint flicker. If this flicker is missing, the DRU is not running properly and must be reset by switching off the AQS chassis for about 10 seconds.

**ADC LED**

This green ,ADC' LED indicates a running Acquisition.

**LAN TX LED**

This green ,LAN TX' LED indicates outgoing LAN traffic.

**LAN RX LED**

This green ,LAN RX' LED indicates incoming Reset and Operation LED Display

**ERROR LED**

The red ,ERROR' LED indicates a pending ERROR.

**READY LED**

Normal operation is indicated by the green ,READY' LED.

Every 500ms this LED is turned off for 20ms, resulting in a faint flicker. If this flicker is missing, the DRU is not running properly and must be reset by switching off the AQS chassis for about 10 seconds.

**ADC LED**

This green ,ADC' LED indicates a running Acquisition.

**LAN TX LED**

This green ,LAN TX' LED indicates outgoing LAN traffic.

**LAN RX LED**

This green ,LAN RX' LED indicates incoming LAN traffic.LAN traffic.

## 12.3 Servicing the DRU

---

Diagnosis and servicing access to the DRU relies on HTTP, enabling service access just by any web browser. This is possible because only basic HTTP V1.1 protocol elements have been used.

### 12.3.1 Accessing the DRU

---

Depending on the slot and the rack code, the DRU adopts one of the following IP addresses. Any illegal or unknown configuration is mapped to DRU1 and the message „Illegal Rack/Slot configuration. Fallback to DRU1 address.“ is written to the DRU Log.

IP Address	DRU Name
149.236.99.89	dru1
149.236.99.88	dru2
149.236.99.87	dru3
149.236.99.86	dru4
149.236.99.85	dru5
149.236.99.84	dru6
149.236.99.83	dru7
149.236.99.82	dru8

Table 12.1 IP Addresses for DRU

It might be useful to edit the hosts file.

In case of problems:

- check the RJ45 cabling between DRU, Ethernet switch and the workstation
- check the ethernet switch power if appropriate
- check the DRU heart beat (flicker of ,READY LED)
- ping DRU1 (DRU2...)
- check LAN ,RX/TX' LED while pinging

If you have a working Topspin installation type „ha“ and select „DRU“. This opens a browser window and loads the DRU start page.

To access the DRU without Topspin, start your favorite web browser and type „149.236.99.89“ as URL.

## 12.3.2 Downloading New Firmware

---

### **Main → DRU Information → DRU Firmware**

leads you to a page giving information about the current firmware.

- i** The document caching of the browsers can be tricky - make sure your browser doesn't fool you with old data. Most browsers have some „Reload“ button for this purpose.

### **Main → AQS Firmware Setup → Program new DRU firmware**

leads you to a page allowing to download new firmware. The current firmware file name is displayed together with a prompt for the new firmware file.

The following example explains the naming convention:

DRU\_firmware\_040325.hex

040325 is a date code for March 25, 2004. Alphabetically sorted, the newest file is found at the bottom line.

- i** Do not download an older firmware than the currently installed one, except you want to roll back in time.

### **Main → DRU Service → Display logged messages**

shows a page containing the main log. If you are in the situation to report a software bug, it's a good idea to include this log. You can copy the text part into an explaining mail or you can save the whole HTML page and attach it.

## 12.4 Technical Data

---

### ADC Data Input

Data Rate 2\*20 MS/s

### NMR Data Output (Ethernet)

Data Rate 0.3 - 10'000 kS/s<sup>1</sup>

Data Word Width 32 bits

### Acquisition Modes

Quadrature off acquisition (only channel A, analog and digital modes) QF

Quadrature simultaneous acquisition (analog and digital modes) QSIM

Acquisition with Digital Quadrature Detection (digital mode only) DQD

### Digital Quadrature Detection (Digital Down Conversion)

DDS frequency range (LO3) +/- (0...5) MHz

Digital Mixer Operation SSB

### Digital Filter type ,smooth'

Passband Error 0.01 % max

Transition Region 15 % SWH

Stopband Attenuation 86 dB min

Group Delay 20 samples

Bandwidth (SWH) 5 MHz max

### Digital Filter type ,medium'

Passband Error 0.001 % max

Transition Region 10 % SWH

Stopband Attenuation 103 dB min

Group Delay 36 samples

Bandwidth (SWH) 2.222 MHz max

### Digital Filter type ,sharp'

Passband Error 0.001 % max

Transition Region 5 % SWH

---

1. complex data points

Stopband Attenuation	104 dB	min
Group Delay	68	samples
Bandwidth (SWH)	1.25 MHz	max

**Miscellaneous**

Direct accessible Scan Memory Size	4M	samples
Banked Scan Memory Size	16M	samples
Sustained LAN data rate (depending on Workstation)	45	Mbit/s
Trigger output:		
Voltage Level	5	V
Impedance	50	Ohm
max Frequency	1	MHz

**Trigger Output**

Voltage Level	5	V
Impedance	50	Ohm
max Frequency	1	MHz

## 12.5 Backplane Connectors

	z	a	b	c	d	e	f
1	GND	GND	INTRA_STATUS~	NC	GND	SAMPLE_INFO0~	GND
2	GND	NC	GND	SAMPLE_INFO3~	SAMPLE_INFO2~	SAMPLE_INFO1~	GND
3	GND	GND	NC	I2C_STATUS~	GND	SAMPLE_INFO4~	GND
4	GND	20MHZ_CLK_X	GND	INTERLEAVE_INCR~	NC	ADC_SEL0	GND
5	GND	GND	20MHZ_CLK_X~	NC	GND	NC	GND
6	GND	NC	GND	NC	NC	INTRA_WUP~	GND
7	GND	NC	NC	NC	GND	RGP_ADC~	GND
8	GND	NC	GND	NC	NC	DWELL_EN~	GND
9	GND	NC	NC	NC	GND	NC	GND
10	GND	SBS_TTL_TX	GND	SBS_TTL_RX	SBS_TTL_TX_ENAB~	NC	GND
11	GND	LOCAL_TX	LOCAL_RX	SBS_TTL_WUP~	GND	RGP_HPPR~	GND

### Key Area

15	GND	SLOT2	SLOT1	SLOT0	GND	RESERVE_ADC_1	GND
16	GND	SLOT3	GND	I2C1_SDA	RESERVE_ADC_2	GND	GND
17	GND	EMERGENCY_STOP~	NC	I2C1_SCL	GND	ADC_I2C_SDA	GND
18	GND	NC	GND	I2C2_SDA	I2C2_SCL	GND	GND
19	GND	NC	NC	NC	GND	ADC_I2C_SCL	GND
20	GND	NC	GND	NC	NC	GND	GND
21	GND	P5V	P35V	HPPR_+9V	HPPR_+9V	HPPR_+9V	GND
22	GND	P5V	RACK0	N9V	N9V	NC	GND
23	GND	P5V	HPPR_+19V	HPPR_-19V	RACK1	NC	GND
24	GND	P5V	HPPR_+19V	HPPR_-19V	RACK2	NC	GND
25	GND	P5V	HPPR_+19V	HPPR_-19V	RACK3	NC	GND

Table 12.2 DRU backplane connector

	z	a	b	c	d	e	f
1	GND	P5V	P5V	P5V	P5V	P5V	GND
2	GND	NC	NC	GND	NC	GND	GND
3	GND	ADC_I2C_SDA	GND	L3_OPT	GND	LCLK_OPT	GND
4	GND	ADC_I2C_SCL	GND	L3_OPT~	GND	LCLK_OPT~	GND
5	GND	GND	L_CLK	GND	L_DATA_3	GND	GND
6	GND	GND	L_CLK~	GND	L_DATA_3~	GND	GND
7	GND	L_OVR0	GND	L_DATA_2	GND	NC	GND
8	GND	L_OVR1	GND	L_DATA_2~	GND	NC	GND
9	GND	GND	L_DATA_1	GND	L_DATA_0	GND	GND
10	GND	GND	L_DATA_1~	GND	L_DATA_0~	GND	GND
11	GND	NC	GND	RESERVE_1	GND	RESERVE_2	GND

Table 12.3 DRU extension connector

# 13 AQS SGU/3

## 13.1 Introduction

---

The AQS SGU/3 is a dual channel broadband synthesizer for Avance III HD spectrometers. The AQS SGU/3 is available for three different nuclei ranges (SGU/3 LF, SGU/3 600 and SGU/3 1200).

Compared to the former AQS SGU/2 the AQS SGU/3 has improved rf performance, e.g. phase noise. It consists of two independent channels. One AQS/3+ chassis can be equipped with up to six SGU/3 channels.

The AQS SGU/3 is controlled by the AQS Controller Software which is part of the AQS DRU firmware. The communication between the AQS DRU and the SGU/3 goes via a synchronous serial rack bus (SSRB).

One SGU/3 channel is selected to be the observing channel and generates the LO and the receiver timing. This can be any SGU/3 channel in the chassis depending on the frequency channel chosen as the OBS (observe) in the edsp menu.

Each SGU/3 channel has a dedicated hard-wired LVDS link to an F-Controller of the IPSO. The high-speed link transfers all NMR relevant real-time events in two 12.5ns time slots to the corresponding SGU/3 channel (e.g. pulses, amplitude, phase, frequency etc.). Each rf channel is controlled by a separate high-speed link. It is connected via a LVDS cable on the front panels of the two units (point to point connection).

## 13.2 Functions/Description

---

### 13.2.1 Important Functions

---

The AQS SGU/3 has the following important functions:

- Generation of the precise final transmission frequency using the on-board frequency synthesizer. Digital pulse generation and shaping. The real time instructions are received from the IPSO via LVDS.
- Generation of the blanking signals for the amplifiers
- Generation of the tune signal for ,wobb‘
- Downloadable DDS functionality due to FPGA technology

Observing SGU/3 channel:

- Generation of gating pulses used in preamplifiers, receiver and DRU
- Generation of the dwell enable signal for the DRU
- Generation of LO signal for the receiver

### 13.2.2 LO Signal Routing

The LO signal for the receiver is generated on the observing SGU/3 channel and daisy-chained through all the succeeding SGU/3 to the receiver. This daisy chain is unidirectional in the direction of the receiver. E.g. in a six channel system with SGU channel 3 set OBS, SGU/3 channel 1 will generate the LO and is daisy-chained through the third SGU/3 to the receiver (see Figure 13.1).

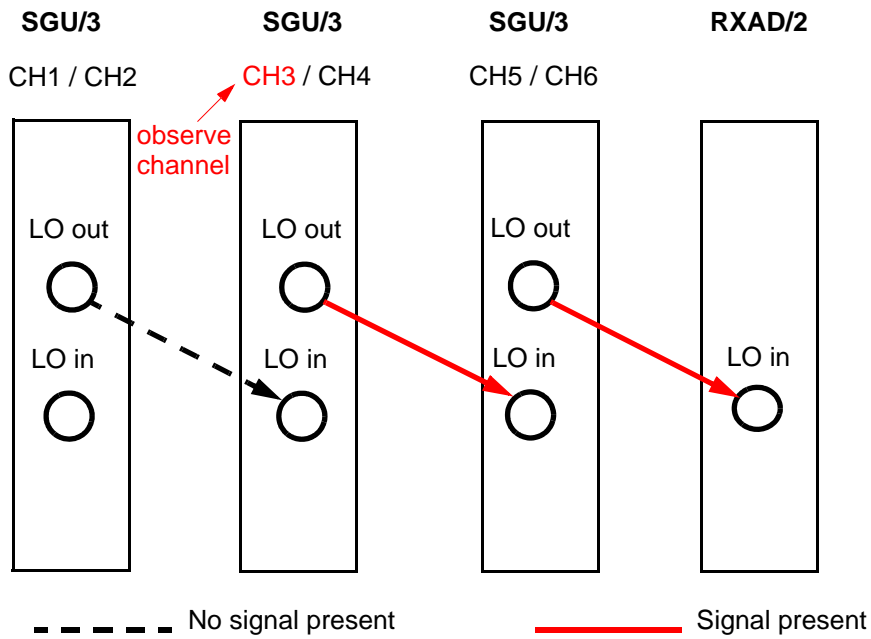
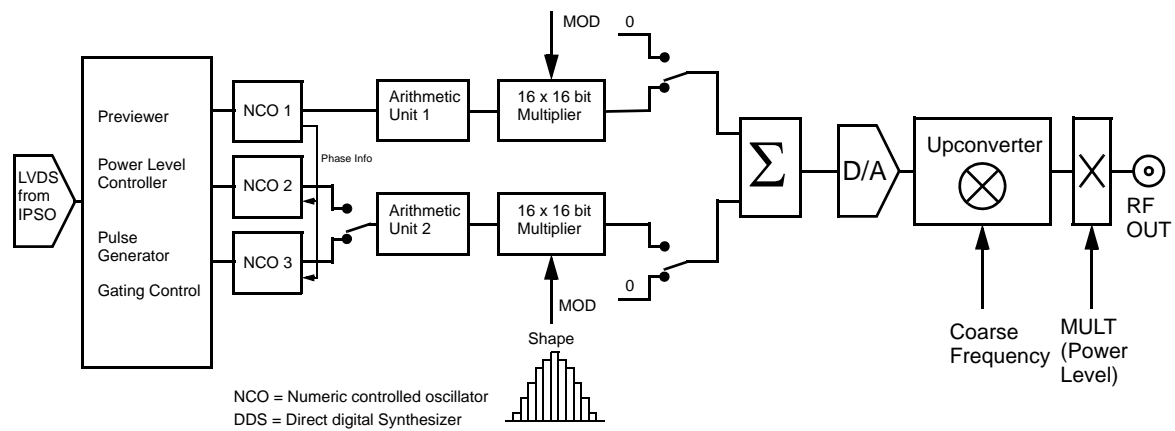

Figure 13.1 LO Daisy-chain for channel 3 (channel 1 of SGU 2) configured as observe channel

### 13.2.3 Signal Generation Inside the SGU/3

The RF signal generation is shown schematically in . Note that the signal path switching is controlled via the LVDS Interface.





Signal generation inside an SGU/3 channel

The core of each SGU/3 channel consists of three NCOs (Numerically Controlled oscillators) NCO1, NCO2, NCO3. NCO0 is used for zero transmission. NCO1 is always used for the OBS frequency. Any shifts in frequency are implemented using NCO2.

NCO3 is always used for the LO frequency.

The advantage of using multiple NCOs is that frequency, amplitude and phase information can be loaded simultaneously. This facilitates instantaneous switching from one phase or frequency to another etc.

The timing of the NCO output is controlled by a series of instructions transmitted by the IPSO via LVDS with a 12.5ns timing resolution.

The output of the different NCOs is a digital representation of all characteristics of the required signal. This digital signal can be modulated using the 'MOD' input to implement the shape of the signal. At this point the signal is still digital which is then passed through a DAC to generate an analog output. The signal at this stage has still not the final frequency. This is obtained with the up converter which mixes the oscillator frequency with the appropriate frequency from the REF unit to produce the final transmission frequency. The last step is the power level adjust ('MULT') which sets the overall amplitude of the RF output.

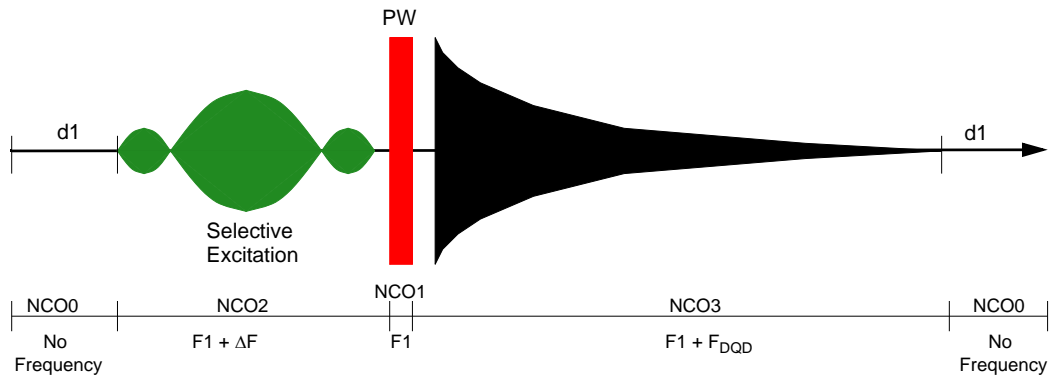

Figure 13.2 NCO allocation

## 13.2.4 RF Routing Inside the SGU/3

Depending on the observe configuration of the two SGU/3 channels the RF routing of the LO and transmit signal is set differently. The possible settings are shown below.

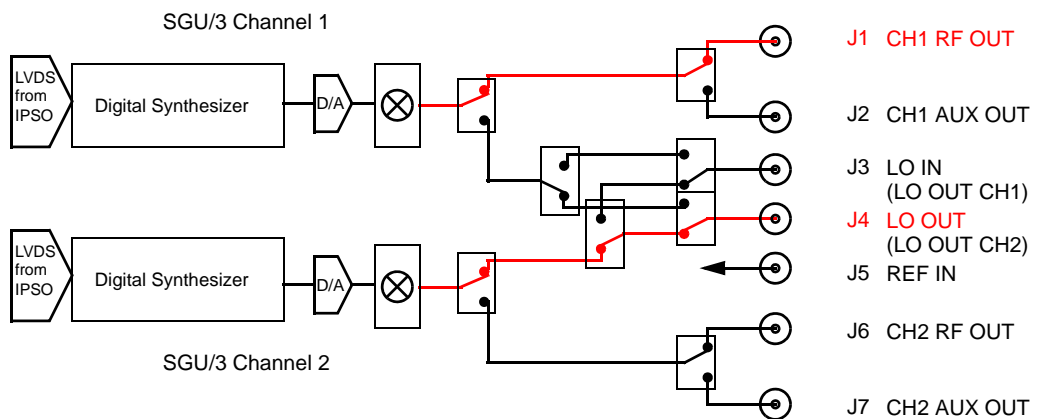

Figure 13.3 Channel 1 transmit, channel 2 observe

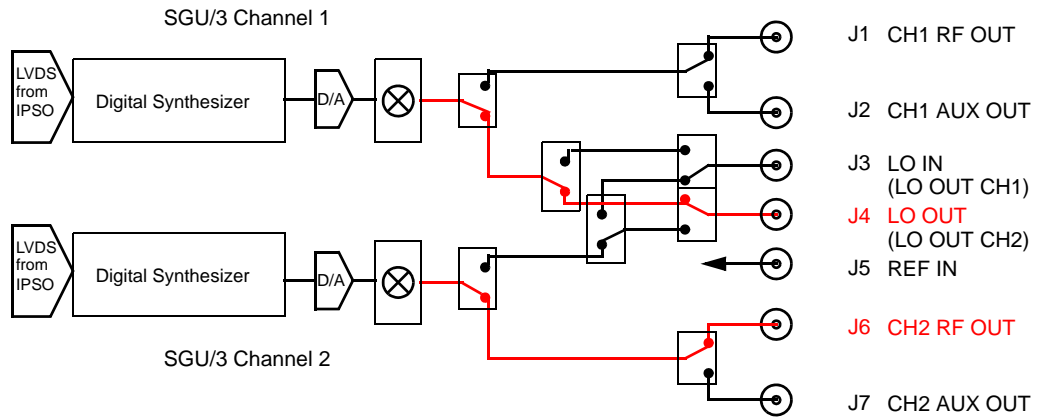

Figure 13.4 Channel 1 observe, channel 2 transmit

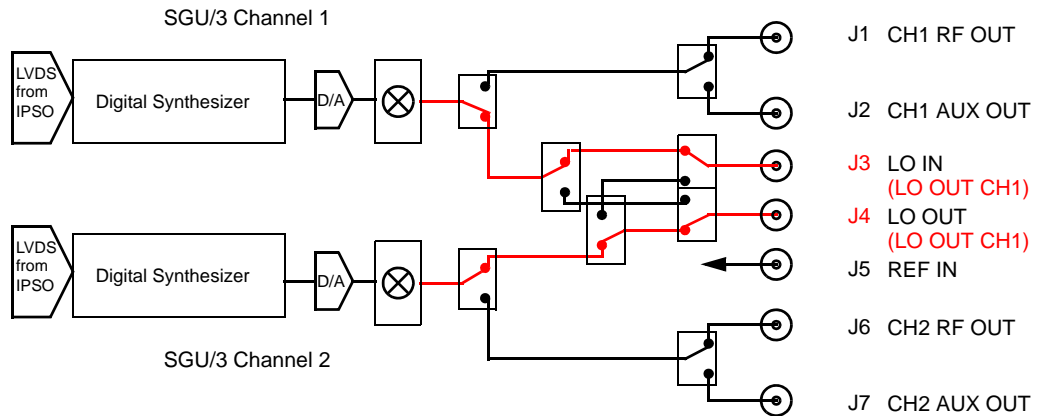

Figure 13.5 Channel 1 observe, channel 2 observe (dual receive mode)

### 13.2.5 Intelligent Pulse Generation

A built-in previewer manages all delays required by the different hardware. Pre- and postdelays for transmitter, preamplifier and receiver are generated automatically and can be configured on the SGU/3 (Figure 13.6).

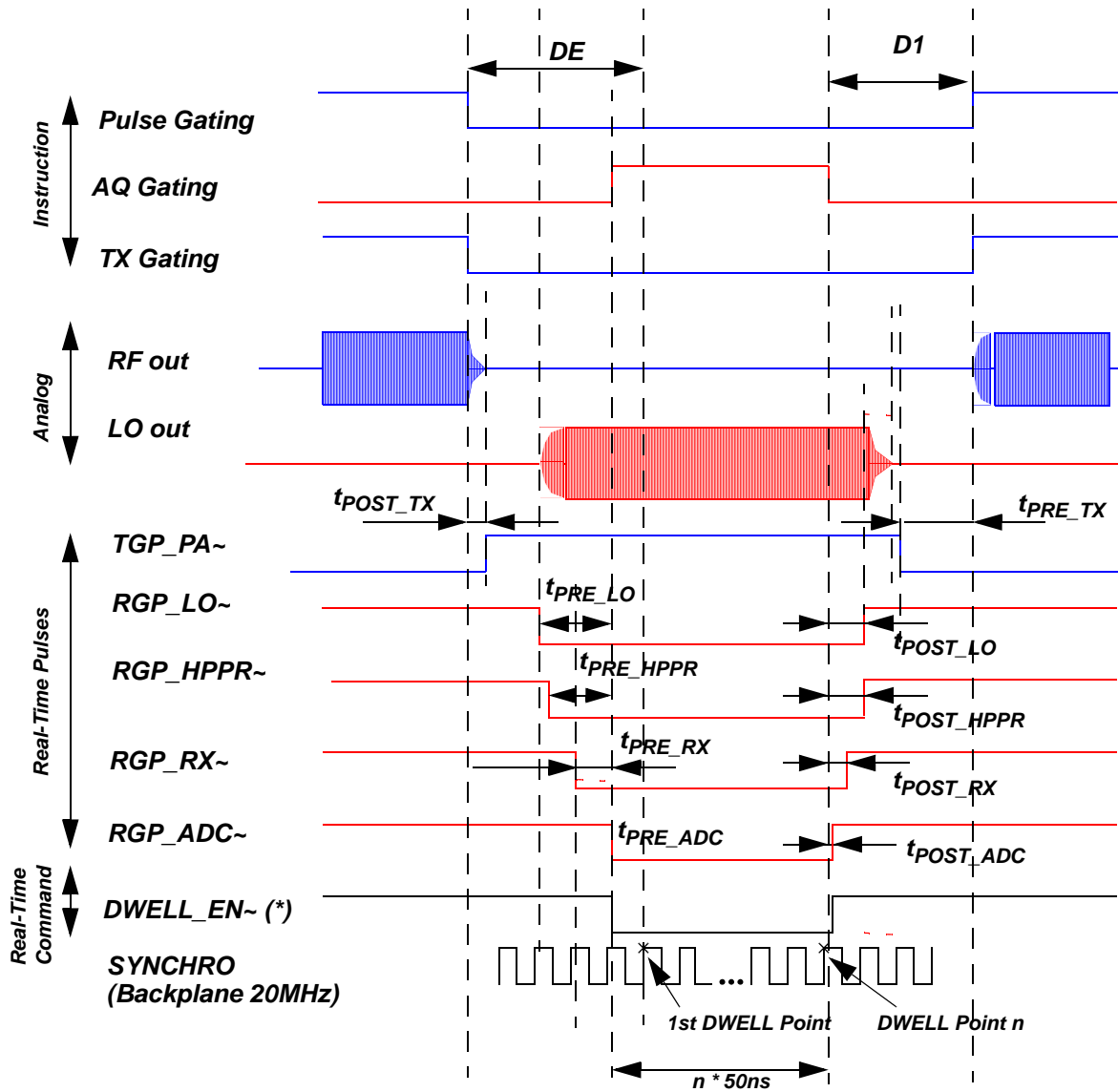

Figure 13.6 Pulse generation inside the SGU/3

### 13.3 Front Panel Wiring / Display

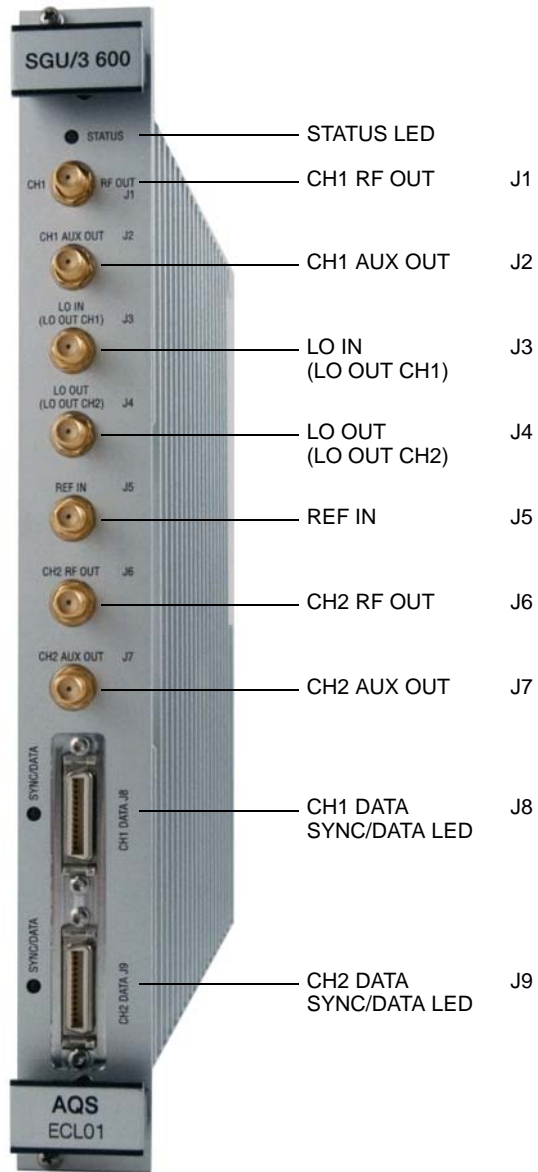

































Figure 13.7 SGU/3 front panel

## 13.3.1 LED Display

STATUS	SYNC/DATA CH1	SYNC/DATA CH2	Description
off 	off 	off 	Power is off or at least one of the power supplies is low
blinking 	off 	off 	Board is in diagnostic mode
blue 	off 	off 	REF-Signal missing / Synchronisation reset sequence active
green 	green 	green 	SGU/3 is ready, both Channels are ready for operation
green 	yellow 	green 	SGU/3 is ready, data link on Channel 1 active
green 	green 	yellow 	SGU/3 is ready, data link on Channel 2 active
green 	off 	green 	SGU/3 is ready, Channel 1 not synchronized with IPSO
green 	green 	off 	SGU/3 is ready, Channel 2 not synchronized with IPSO
red 	red 	green 	Error on SGU/3 Channel 1

STATUS	SYNC/DATA CH1	SYNC/DATA CH2	Description
red 	green 	red 	Error on SGU/3 Channel 2
yellow 	green 	green 	Serial communication to SGU/3 active In case of static yellow LED: status message pending on SGU/3

### 13.3.2 Front Panel Connectors

#### J1 CH1 RF OUT

Channel 1 RF output for transmitter signal

#### J2 CH1 AUX OUT

Channel 1 auxiliary output for wobble/transmitter signal

#### J3 LO IN (CH1 LO OUT)

LO signal input for receiver LO daisy chain

In case of a dual receiver system the connector is used as output for the first channel's LO signal.

#### J4 LO OUT (CH2 LO OUT)

Output of receiver LO signal

LO signal output for second channel's LO signal in dual receiver configuration

#### J5 REF IN

Reference signal input from REF/3 unit

#### J6 CH1 RF OUT

Channel 2 RF output for transmitter signal

#### J7 CH2 AUX OUT

Channel 2 auxiliary output for wobble/transmitter signal

## 13.4 SGU/3 FPGA Firmware

In contrast to the SGU/2 the SGU/3 needs only one firmware called the SGU/3 FPGA software. The firmware can be downloaded via the DRU web page.

### 13.4.1 SGU/3 Firmware Version Encoding

The FPGA firmware for the AQS SGU/3 is compressed data with file name syntax <SGU3\_YYMMDD.gz>

YY = Year, MM = Month, DD = Day

### 13.4.2 Identification of the Firmware Release

The AQS Firmware setup page (Main>AQS Firmware setup>Download new Firmware into AQS Devices) lists the active and the required firmware version for each unit in the AQS system.

### 13.4.3 SGU/3 Firmware Download

To update the AQS SGU/3 firmware please follow these instructions:

1. Click on "Select SGU/3 Firmware" on the AQS Firmware setup page and select the SGU/3 firmware file SGU3\_120130.gz.
2. Tick "Downloading" in the corresponding SGU/3 row.
3. Select button "Download ticked AQS Firmware"

## 13.5 Part Numbers

Z117129 SGU/3 600 (Frequency range 5...650 MHz)

Z117130 SGU/3 1200 (Frequency range 5...1290 MHz)

Z117131 SGU/3 LF (Frequency range 0.003...440.0 MHz)

## 13.6 Error Messages

Description of possible error messages:

Error No.	Error Message	Description	Possible cause
Error No. 5	Selected board not inserted	SBSB address does not match with the device identifier of the command	Hardware and software configuration are different; reconfiguration ('cf') needed
Error No. 13	Power failed	A power up has occurred and the system is not initialized	Ordinary power up or a power breakdown during an experiment



Error No.	Error Message	Description	Possible cause
Error No. 15	Parameter exceeds valid range	Value out of range	Spectrometer control software failure or faulty input using DRU Web-Tool
Error No. 17	Function not supported by board hardware version		SGU/3 with newer ECL required
Error No. 20	Syntax error	Selected feature not supported by actual firmware, board does not understand command	Spectrometer control software failure, wrong board selected, hardware feature not supported by actual version
Error No. 21	Command not available for this HW version		SGU/3 with newer ECL required
Error No. 58	Corrupt BIS on board	BIS (Board Information System) test failed	Hardware failure
Error No. 59	BIS checksum error	BIS (Board Information System) test failed	Hardware failure
Error No. 64	LVDS data link: parity bit fault	Parity bit fault on LVDS data link	LVDS data link disconnected and reconnected
Error No. 65	LVDS data link: synchronization bit fault	Synchronization bit fault on LVDS data link	LVDS data link disconnected and reconnected
Error No. 66	LVDS data link: instruction alignment fault	Alignment error on LVDS data link	FPGA reset on SGU/3
Error No. 67	Real-time instruction timing violation: DE time too short	Timing check error while changing to acquisition state	Time between transmit and acquisition too short
Error No. 69	Real-time instruction timing violation: SGU pre-delay 1 time too short	Timing check error while changing to tune state	Time between two tune sequences too short
Error No. 70	Real-time instruction timing violation: SGU pre-delay 2 time too short	Timing check error while changing to homo decoupling state	Time between transmit and homo decoupling too short
Error No. 71	Real-time instruction fault: invalid gating state transition	Invalid state transition of the gating state machine	Error in gating instruction from IPSO
Error No. 72	Real-time instruction fault: unknown instruction	Unknown real time instruction	Invalid real time instruction from IPSO
Error No. 73	Overflow in NCO combiner detected	Sum of amplitudes of NCO1 and NCO2 exceeds maximum value	NCO Amplitudes too high, pulse programming failure
Error No. 74	Scan Info lost	Timing violation while sending a Scan Info Instruction from IPSO via SGU to DRU.	Time between two Scan Info instructions too short.
Error No. 75	Global frequency offset: overflow or underflow in adder	Sum of SGU frequency and global frequency offset (from FRED unit) out of range	Pulse programming failure
Error No. 76	Real-time instruction fault: wrong coarse frequency	SGU PLL frequency out of range	Spectrometer control software failure
Error No. 77	Real-time instruction fault: both channels are observe	Wrong observe setting	Spectrometer control software failure
Error No. 78	Overflow in amplitude combiner	Internal NCO combining overflow	Pulse programming failure
Error No. 87	20MHZ_CLK clock / phase fault. Check clock distribution, cable length of REF_IN J5	Deviance in clock phase between 20 MHz and REF_IN	Check length of REF cable between REF/3 and SGU/3

Error No.	Error Message	Description	Possible cause
Error No. 88	DUC sync fail	Internal synchronization error	Hardware failure
Error No. 89	DUC CCI overflow	Internal data transmission error	Real time instruction error / Hardware failure
Error No. 90	DCM DUC sync clock fail	Internal synchronization error	Hardware failure
Error No. 91	DCM DUC pd clock fail	Internal clock error	Hardware failure
Error No. 92	PLL DDS sync fail	Internal synchronization error	Hardware failure
Error No. 93	DCM PLL DDS sync clock fail	Internal clock error	Hardware failure
Error No. 94	Synchro 20MHz (backplane) fail	20 MHz clock signal missing	Signal path REF/3 -> Backplane -> SGU/3 interrupted
Error No. 95	SSRB address error in reply	Communication error DRU <-> SGU/3	DRU firmware error / hardware error
Error No. 96	Corrupt data in flash	Internal configuration data corrupted or missing	Hardware failure
Error No. 97	80MHZ clock error. Check if REF IN (J5) is connected to a Reference Board and restart the system	Reference signal from REF/3 low or missing	Inadequate connection between REF/3 and SGU/3
Error No. 98	SSRB last command failed	Communication error DRU <-> SGU/3	DRU firmware error / SGU/3 FPGA error
Error No. 99	SSRB time-out error	Communication error between DRU and SGU/3	Clock signal missing on SGU/3 Check REF connection on J5
Error No. 103	Can not set both channels to observe (Only allowed in Multi-RX configurations or in interleaved acquisition mode)	Hardware and software configuration do not match	Spectrometer control software failure, reconfiguration ('cf') needed
Error No. 104	Flash table does not exist.	Flash table for hardware configuration on SGU/3 missing	Hardware failure
Error No. 106	SGU Multi-RX configuration not possible in that slot	SGU/3 in wrong slot for dual receive configuration	Put SGU/3 in slot 0 for dual receive configuration, reconfiguration ('cf') needed
Error No. 108	SGU PLL lock lost or PLL unlock error	Phase-locked loop unlocked	Hardware failure
Error No. 109	SGU frequency out of range	The set frequency is not in the valid range for the present board	Spectrometer control software failure, reconfiguration ('cf') needed
Error No. 110	Emergency stop activated, SGU forced to reset. Hint: Check HPPR/2 for emergency stop occurrence first	An emergency stop signal from backplane was detected	Emergency stop signal activated by any spectrometer unit
Error No. 114	Command not available for this channel	An SGU/3 board command was sent to an SBSB address of a single channel	spectrometer control software failure, wrong channel selected
Error No. 116	Power supply failure detected	One or more (internal) power supplies are low	failure of external or internal power supply

## 13.7 Important Signals

---

All signals described below are active low with TTL level. An exception are the blanking signals which use an open drain configuration.

### **BLKTR (Amplifier Blanking Pulses)**

The SGU/3 can control up to eight power amplifiers with the corresponding BLKTR. The timing of the blanking pulses is controlled by the pulse gating from the IPSO and the configured pre and post delays of the SGU/3. All SGU/3 channels are capable of generating blanking pulses.

The internal amplifiers receive the blanking directly from the backplane, whereas the external amplifiers receive the signals from the PSM/A which receives the signals from the backplane.

### **RGP\_HPPR~ (Preamplifier Receiver Gating Pulse)**

This pulse is generated by the observe SGU/3 channel and is used to gate the OBS module on the HPPR (transmit / receive switching). The timing of the pulse can be modified with the 'edscon' parameters. This signal is routed via the PSM/A to the observe module in the preamplifier HPPR/2. All other non-lock HPPR modules are left in transmission mode permanently.

### **RGP\_LO~ (Local Oscillator Gating Pulse)**

This pulse is generated by the observe SGU/3 channel. It indicates a valid LO signal for the receiver.

### **RGP\_RX~ (Receiver Gating Pulse)**

This pulse generated by the observing SGU/3 channel enables the receiver and is transmitted directly over the backplane. The timing of the pulse can be modified with the 'edscon' parameters.

### **RGP\_ADC~ (ADC Gating Pulse)**

This pulse (also driven by the observe SGU/3 channel) controls the ADC data. If the pulse goes low and a dwell enable is active the ADC is sampling data. If the pulse is high and a dwell enable is active the ADC generates zero-data. The RGP\_ADC is routed over the backplane to the ADC. This signal is also used for digital homo decoupling with oversampling.

### **DWELL\_ENABLE~**

The signal is driven by the observe SGU/3 channel and is used to control the timing of the A/D conversion. A low level of this signal enables ADC conversion. The signal is generated on the SGU/3. The timing is controlled by the IPSO. The pulse is routed over the backplane to the DRU.

## 13.8 Specifications

---

### 13.8.1 Timing

---

Minimum Pulse or delay duration: see specification of IPSO.

**Time Resolution: 12.5ns**

The resolution is given by the internal 80MHz clocking frequency of the SGU/3. Thus pulses or delays between pulses can be set to multiples of 12.5ns.

### 13.8.2 Frequency

---

**Frequency Range:**

SGU/3 600: 5.0 - 650.0 MHz  
SGU/3 1200: 5.0 - 1290.0 MHz  
SGU/2 LF: 0.003 - 440.0 MHz

**Frequency Stability:**

This is governed by the stability of the crystal oscillator on the REF unit which is specified to  $\pm 0.5 \times 10^{-9}$ /day and  $\pm 5 \times 10^{-8}$ /year.

**Frequency Resolution:**

The DDS is clocked by 80MHz and the frequency setting is stored in a 34 bit register →  $80 \text{ MHz}/2^{34} < 0.005 \text{ Hz}$ .

**Frequency Switching Time:**

Instruction time for frequency steps: 25 ns with resolution of 12.5 ns. Further information on response time of analog hardware: see section "[Hardware Response](#)" on page 165

### 13.8.3 Phase

---

**Phase Resolution:**

A 16 bit register is used to store phase values. →  $360^\circ/2^{16} < 0.006^\circ$

**Phase Switching Time:**

Instruction time for phase steps: 25 ns with resolution of 12.5 ns.

Total response time for any phase step to a phase error with less than  $1^\circ < 300\text{ns}$ . Further information on phase settling time: see section "[Hardware Response](#)" on page 165

### 13.8.4 Amplitude

#### Modulator Range:

The Modulator values are stored in a 16 bit register which equates to a voltage dynamic range of 96dB. ( $20 \log(2^{16}) = 96 \text{ dB}$ ).

#### Power Level Range:

The Power Level values are stored in a 15 bit register which equates to a voltage dynamic range of 90dB. ( $20 \log(2^{15}) = 90 \text{ dB}$ )

Power Level resolution: 0.1 dB

#### Amplitude Switching Time:

Instruction time for amplitude: 25ns

Response time of analog hardware: <100ns

### 13.8.5 Hardware Response

The SGU/3 frequency, amplitude (MOD) and power level (MULT) registers can be set within 12.5ns, the actual update rate is limited by the serial link and the event synchronization to 25ns. The time until the new values are set on the output can be much longer because of the limited bandwidth in the analog sections inside the SGU/3. This additional time is called response time or settling time.

The settling time is independent of change frequency or phase. A quite hard test is to change phase by  $180^\circ$  and measure the time elapsed to achieve a remaining error of  $<1^\circ$ .

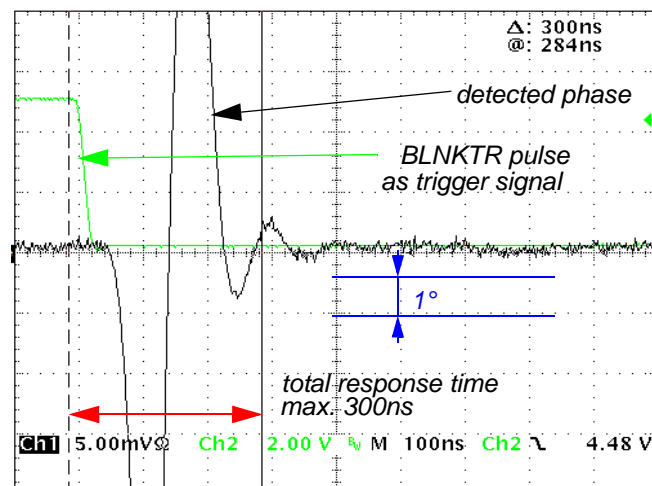

Figure 13.8 Response  $180^\circ$  phase step

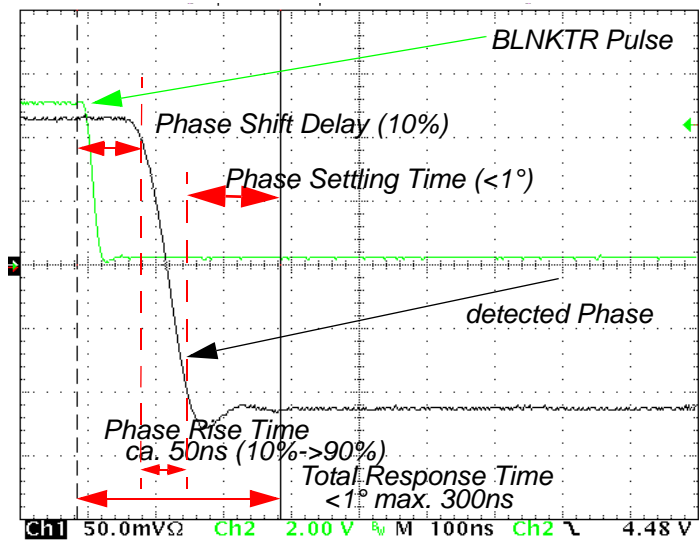

Figure 13.9 Response 90° step (45°/+135°)

## 13.9 Power Supply / Fuses

see 13.3.1

### 13.9.1 Backplane Connector

	z	a	b	c	d	e	f
1	GND	GND	NC	NC	GND	SAMPLE_INFO0~	GND
2	GND	P3V6	GND	SAMPLE_INFO3~	SAMPLE_INFO2~	SAMPLE_INFO1~	GND
3	GND	GND	P3V6	NC	GND	SAMPLE_INFO4~	GND
4	GND	20MHZ_CLK_X	GND	INTERLEAVE_INCR~	RESERVE(0)	P3V6	GND
5	GND	GND	20MHZ_CLK_X~	P3V6	GND	RGP_LO~	GND
6	GND	BLNKTR1~	GND	BLNKTR2~	NC	P3V6	GND
7	GND	BLNKTR3~	BLNKTR4~	RESERVE(1)	GND	RGP_ADC~	GND
8	GND	BLNKTR5~	GND	BLNKTR6~	NC	DWL_ENAB~	GND
9	GND	BLNKTR7~	BLNKTR8~	NC	GND	RGP_RX~	GND
10	GND	NC	GND	NC	NC	P3V6	GND
11	GND	NC	NC	NC	GND	RGP_HPPR~	GND

#### Key Area

15	GND	SLOT2	SLOT1	SLOT0	GND	NC	GND
16	GND	SLOT3	GND	NC	NC	GND	GND
17	GND	EMERGENCY_STOP~	NC	NC	GND	NC	GND
18	GND	P3V6	GND	NC	NC	GND	GND
19	GND	SSRB_STXD	SSRB_SCLK	SSRB_SINTR~	GND	NC	GND
20	GND	SSRB_SRXD	GND	NC	NC	GND	GND
21	GND	P5V	P35V	P9V	P9V	P9V	GND
22	GND	P5V	NC	N9V	N9V	N9V	GND
23	GND	P5V	P19V	N19V	NC	NC	GND
24	GND	P5V	P19V	N19V	NC	NC	GND
25	GND	P5V	P19V	N19V	NC	NC	GND

Table 13.1 SGU/3 backplane connector

	z	a	b	c	d	e	f
1	GND	RX2_SAMPLE_INFO0~	RX2_SAMPLE_INFO1~	RX2_SAMPLE_INFO2~	RX2_SAMPLE_INFO3~	RX2_SAMPLE_INFO4~	GND
2	GND	RX2_RGP_LO~	RX2_RGP_HPPR~	RX2_RGP_RX~	RX2_RGP_ADC~	RX2_INTERLEAVE_INCR~	GND
3	GND	RX2_DWL_ENAB~	NC	NC	NC	NC	GND
4	GND	NC	NC	NC	NC	NC	GND
5	GND	NC	NC	NC	NC	NC	GND
6	GND	NC	NC	NC	NC	NC	GND
7	GND	NC	NC	NC	NC	NC	GND
8	GND	NC	NC	NC	NC	NC	GND
9	GND	NC	NC	NC	NC	NC	GND
10	GND	NC	NC	NC	NC	NC	GND
11	GND	NC	NC	NC	NC	NC	GND

Table 13.2 SGU/3 extension connector



# 14 AQS Pulse & RF-Splitter

## 14.1 Introduction

---

The AQS PULSE SPLITTER and AQS RF-SPLITTER boards are used for the following signal distribution between AQS/2 or AQS/3 and AQS/2-M chassis:

- 20MHz clock
- 11 receiver (RX) pulses: RGP\_LO~, RGP\_ADC~, RGP\_RX~, RGP\_HPPR~, DWL\_ENAB, INTRLEAVE\_INCR~, SAMPLE\_INFO[0:4] ~
- LO-signal
- LO2-signal

The PULSE SPLITTER board is situated in one of the AQS slots in the front of the AQS/2 or AQS/3 chassis, the RF-SPLITTER in the rear of the AQS/2-M chassis.

PULSE and RF-SPLITTER are connected via a twisted pair cable with Mini-Delta-Ribbon (MDR) connectors. The cable has a differential impedance of 100Ω.

One PULSE SPLITTER can support up to 5 AQS/2-M chassis. Each AQS/2-M chassis needs one RF-SPLITTER board.

LO- and LO2-signals are split in the RF-SPLITTER. Each splitter has one input and 10 outputs. The LO-splitter has an additional input and LO-switch. All splitters are unity gain calibrated. Up to 3 RF-SPLITTER boards can be cascaded.

Both units are equipped with I2C-bus and LED indicator diagnostic features. Gain calibration and LO-switch of the splitters are I2C-bus controlled.

## 14.2 Functions/Description

---

### 14.2.1 20MHz Clock and RX-Pulse Distribution

---

The PULSE SPLITTER board receives both clock and RX-pulses from the user bus and converts them to LVDS-logic level signals. These are transmitted via the MDR-cable to the RF-SPLITTER. It converts them back to their former logic levels and routes them to the user bus.

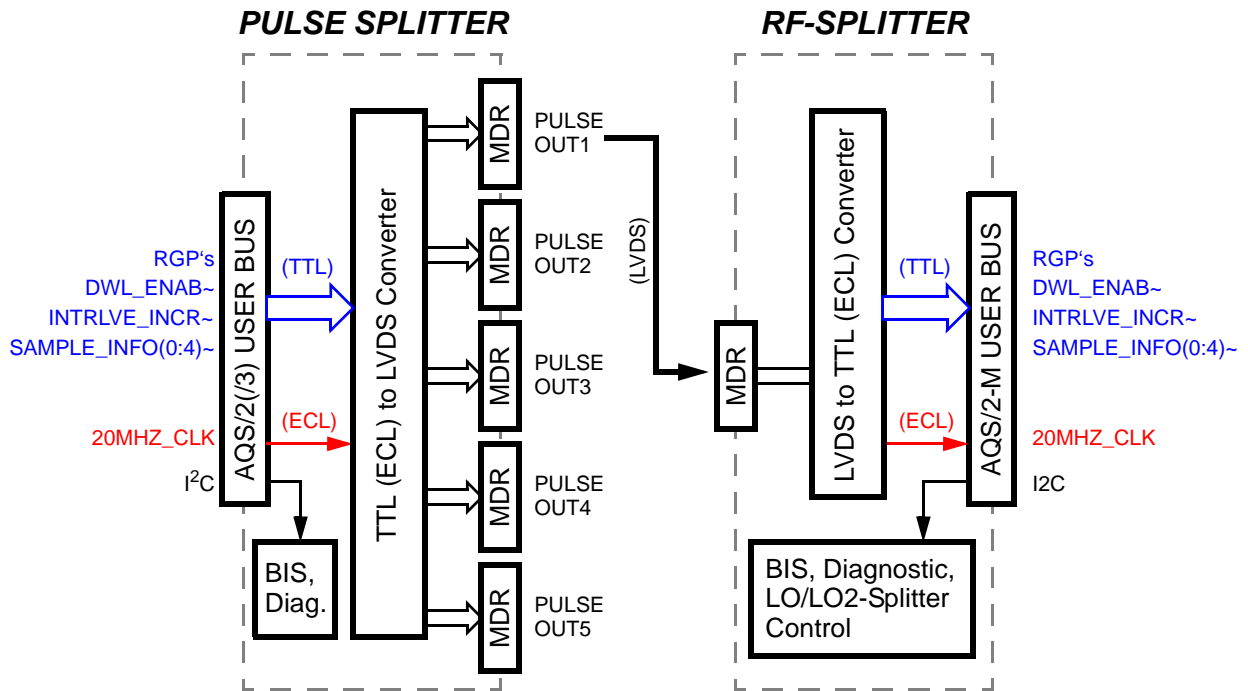

Figure 14.1 Clock & RX-Pulse distribution

## 14.2.2 LO- & LO2-Splitter

Both LO- and LO2-splitters are integrated into the RF-SPLITTER unit.

The LO-output signals from SGU1 and SGU2 are fed into the inputs LO\_IN1 and LO\_IN2. The outputs are either connected to a RXAD or a LO-splitter input on another RF\_SPLITTER unit.

The LO2 output signal from the REFERENCE board is fed into the LO2\_IN1. The outputs are either connected to a RXAD or a LO2-splitter input on another RF\_SPLITTER unit.

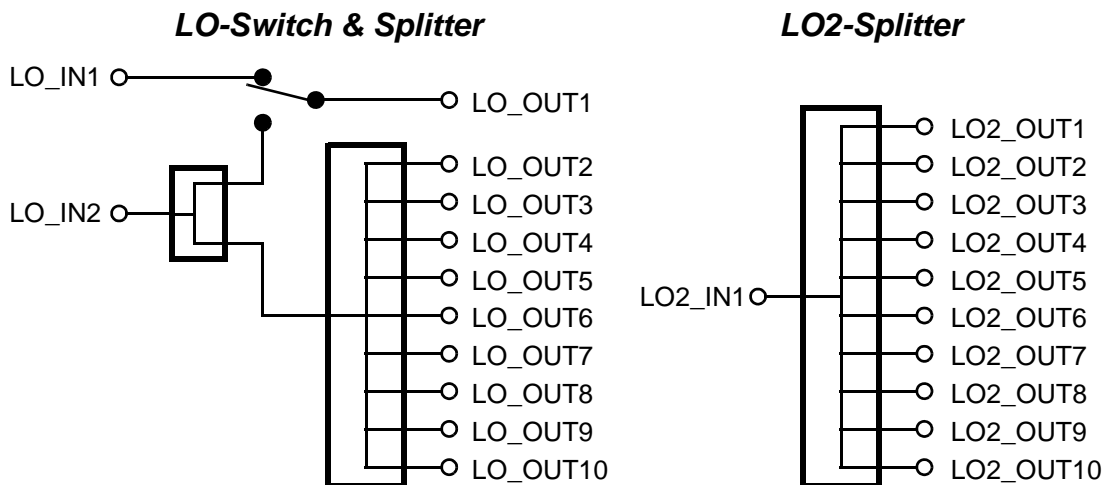

Figure 14.2 LO/LO2- Splitter

## 14.3 RF and Pulse Wiring

**Legend:**

- Front side unit
- Rear side unit

[.]: Number of coaxial cable (SMA)

RF-signal designators refer to the name of the source connector.

**Upgrade Info:**

- black: 2TX/8RX (basic configuration)
- blue: Upgrade to 2TX/16RX
- green: Upgrade to 2TX/32RX

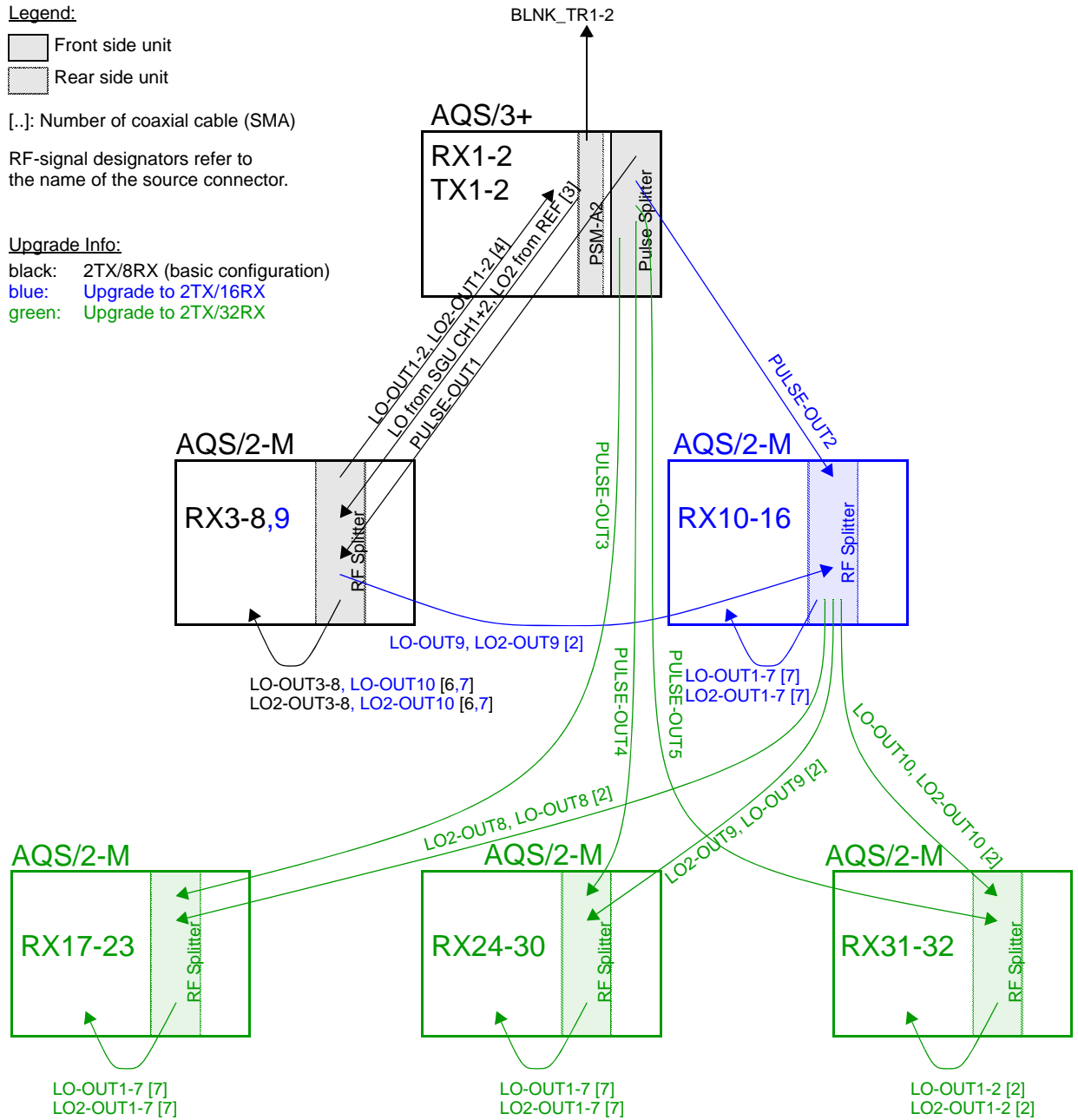

Figure 14.3 PULSE & RF-SPLITTER Wiring Diagram

## 14.4 Front Panel

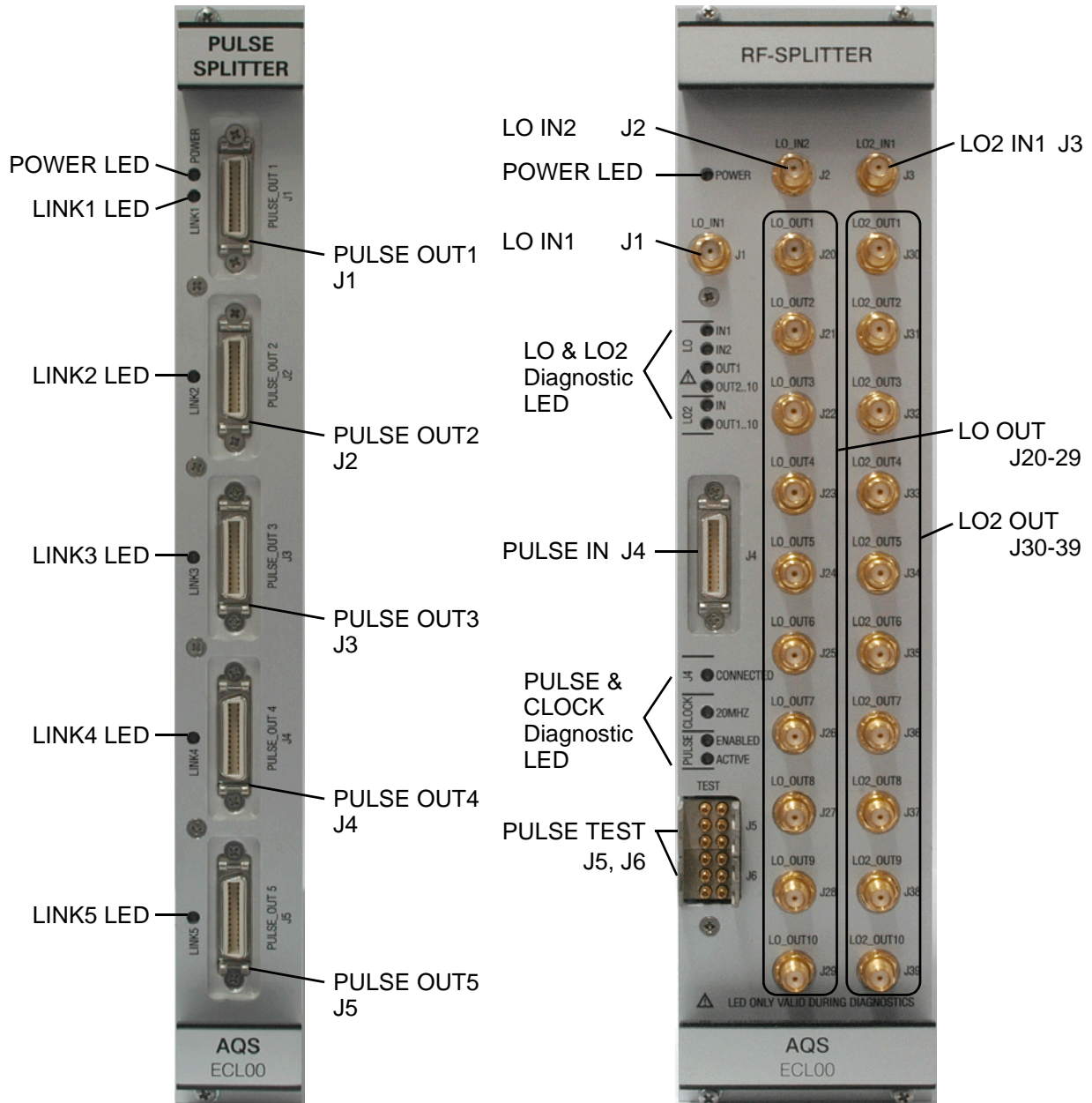

Figure 14.4 AQS PULSE- & RF-SPLITTER boards front panel view

### 14.4.1 LED Indicators

LED Name	Color	Error Description (LED OFF)
POWER	green	power supply failure
LINK1 LINK2 LINK3 LINK4 LINK5	green	MDR cable not connected to AQS RF-SPLITTER

Table 14.1 PULSE SPLITTER LED Error Description

LED Name		Color	Error Description (LED OFF)
POWER		green	power supply failure
LO	IN1 IN2 OUT1 OUT2-10	yellow <sup>a</sup> yellow yellow yellow	no RF-input signal no RF-input signal no RF-output signal no RF-output signal
LO2	IN OUT1-10	green green	no RF-input signal no RF-output signal
J4	CONNECTED	green	MDR cable not connected to AQS PULSE SPLITTER, no pulse output
CLOCK	20MHZ	green	no clock output signal
PULSE	ENABLED ACTIVE	green yellow	pulse buffer disabled, no pulse output no pulse active

Table 14.2 RF-SPLITTER LED Error Description

a. Short pulses may not be visible in OBSERVE mode.

### 14.4.2 Front Panel Connectors PULSE SPLITTER

#### J1-J5 PULSE OUT1-5

Pulse and clock output to RF-SPLITTER board. All signals are in LVDS logic (Low Voltage Differential Signal). These signals can only be measured with proper LVDS termination (100Ω differential).

## 14.4.3 Front Panel Connectors RF-SPLITTER

### J1 LO\_IN1

LO input signal (1Vpp at 50Ω load) from SGU1 or SGU LO-chain. This signal is only present during observe. It can be routed via the internal LO-switch to LO\_OUT1 (J20).

### J2 LO\_IN2

LO input signal (1Vpp at 50Ω load) from SGU2 or SGU LO-chain. This signal is only present during observe. It is split and routed to LO\_OUT2-10 (J21-29). It can also be routed via the internal LO-switch to LO\_OUT1 (J20).

### J3 LO2\_IN1

LO2 input signal (1Vpp at 50Ω load) from REFERENCE board. This signal is split and routed to LO2\_OUT1-10 (J30-39).

### J4 PULSE IN

Pulse and clock input from PULSE SPLITTER. All signals are in LVDS logic.

### J5/J6 TEST

Pulse and clock output test connector. Signal level = 1/10 TTL at 50Ω load. Pin numbers are according to test cable HZ10124 (CABLE 6P300 COAXIPACK ADAP BNC)

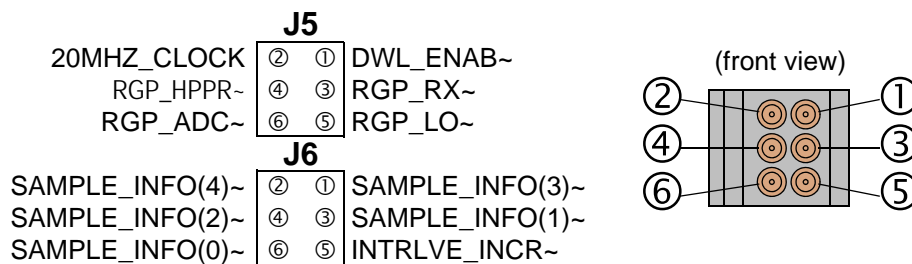

Figure 14.5 Pining J5/J6 Pulse Test Connector

### J20-29 LO\_OUT1-10

LO output signal (1Vpp at 50Ω load) to RXAD or another RF-SPLITTER. These signals are only present during observe.

### J30-39 LO2\_OUT1-10

LO2 output signal (1Vpp at 50Ω load) to RXAD or another RF-SPLITTER.

## 14.5 Diagnostics

The input signals of the PULSE SPLITTER and the output signals of the RF-SPLITTER are monitored by diagnostic circuits. Their status is displayed with LED indicators on the front panel of the units. Please refer to "[LED Indicators](#)" on page 173.

The same information is accessible for the AQS controller via I2C bus. The information may be accessed via the DRU web interface.

(Service web of DRU in Slot 1, see Main / [Hosted Devices](#))

### Device Status

Ready

### Diagnostic

Diagnostic Testpoint	Description	Status
①	Power Supply Monitor (+3.3V, +5V)	o.k.
②	Pulse Input *	all pulses inactive
③	20MHz Clock Input	o.k.
④	LINK 1 (PULSE_OUT 1 J1)	connected
⑤	LINK 2 (PULSE_OUT 2 J2)	not connected
⑥	LINK 3 (PULSE_OUT 3 J3)	not connected
⑦	LINK 4 (PULSE_OUT 4 J4)	not connected
⑧	LINK 5 (PULSE_OUT 5 J5)	not connected
Refresh	<input type="button" value="Refresh F5"/>	



click picture to enlarge

\* pulses only active during acquisition

Figure 14.6 Pulse Splitter Device and Diagnostic Status

### Device Status

Ready

### Diagnostic

Diagnostic Testpoint	Description	Status
①	LO IN1 *	inactive or failed
②	LO IN2 *	inactive or failed
③	LO OUT1 *	inactive or failed
④	LO OUT 2-10 *	inactive or failed
⑤	LO2 IN	failed
⑥	LO2 OUT 1-10	failed
⑦	Pulse Output *	all pulses inactive
⑧	20MHz Clock Output	ok
⑨	Power Supply Monitor (+3.3V, +5V)	ok
Refresh	<input type="button" value="Refresh F5"/>	



click picture to enlarge

Figure 14.7 RF-Splitter Device and Diagnostic Status

## 14.6 RF-Splitter Setup and Gain Adjust

Ready

**Setup**

LO frequency and switch setup	LO IN 1 Frequency	500 MHz		
	LO IN 2 Frequency	500 MHz		
	LO IN select	LO_IN2		
<b>Adjust DAC Values</b>				
LO gain adjust (frequency dependant)	500 MHz	LO OUT 1	149 (0..255)	Up Down
	500 MHz	LO OUT 2-4	133 (0..255)	Up Down
	500 MHz	LO OUT 5-7	151 (0..255)	Up Down
	500 MHz	LO OUT 8-10	148 (0..255)	Up Down
LO2 gain adjust	720 MHz	LO2 OUT 1	159 (0..255)	Up Down
	720 MHz	LO2 OUT 2-4	163 (0..255)	Up Down
	720 MHz	LO2 OUT 5-7	170 (0..255)	Up Down
	720 MHz	LO OUT 8-10	171 (0..255)	Up Down
Pulse driver setup →	Pulse Driver	ENABLE		
	Set/Update modified Values	Set/Update modified Values		
	Write/Save Values into BIS	Write/Save Values into BIS		

Figure 14.8 RF-Splitter Setup Window

### 14.6.1 Setup

#### LO IN 1, LO IN 2 Frequency:

- Enter SGU frequency and press [Set/Update modified Values]

The adjust DAC values are set according to the calibration data list stored in the unit BIS. The controller uses the calibration data closest to the entered frequency value. The frequency display changes to the chosen data set.

#### LO IN select:

LO switch setting (see also "LO- & LO2-Splitter" on page 170)

- LO\_IN1 = LO\_IN1 → LO\_OUT1 and LO\_IN2 → LO\_OUT2-10
- LO\_IN2 = LO\_IN2 → LO\_OUT1-10

#### Pulse Driver:

- ENABLE = pulse driver from RF-Splitter to backplane enabled (Default)
- DISABLE = pulse driver from RF-Splitter to backplane disabled (only used when SGU in AQS/2-M Chassis)



## 14.6.2 Gain Adjust

The gain off the LO and LO2 splitters is adjusted to unity gain at the factory. This includes the connecting cables<sup>1</sup>. However if other cables are used or several RF-Splitters are cascaded, a fine adjust may be necessary. The gain adjusts are bundled as follows:

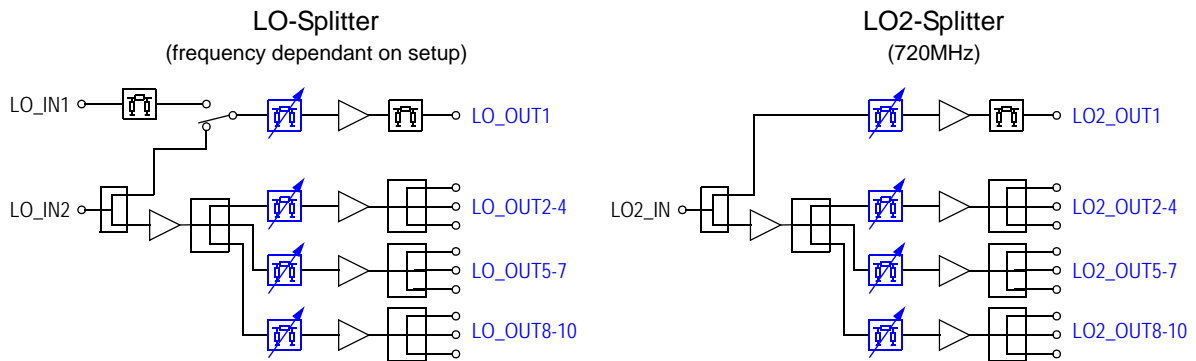

Figure 14.9 RF-Splitter gain adjust DAC

### Gain Adjust Procedure:

1. Disconnect the LO(2)\_OUT cable from the RXAD and connect it to a power meter
2. Check/set the correct RF-Splitter frequency
3. Adjust the gain of the LO channel with the [Up] and [Down] buttons (Adjust value see "[LO-Performance:](#)" on page 178)
4. Save the DAC values with [Write/Save Values into BIS]
5. Repeat the procedure for other frequencies or other LO channels

**i** Make sure that all unused outputs are properly terminated (50Ω)

The four gain adjusts of the splitters are somewhat dependent on each other. If one channel is coarse adjusted, the other channels may detune slightly.

## 14.7 Part Numbers and Cables

- Z104431 AQS PULSE SPLITTER
- Z104432 AQS RF-SPLITTER
- HZ13238 CABLE RD 26P 3M MDR

### Test Equipment:

- HZ10124 CABLE 6P300 COAXIPACK ADAP BNC

1. 2x CABLE COAX ELSPEC 2000 SMA/SMA (HZ04329)

## 14.7.1 Technical Data

---

### 14.7.2 PULSE SPLITTER

---

#### Pulse Performance:

Pulse Input: Logic Level	+5V	TTL
20MHz Clock Input: Logic Level	+2/-2.5V	ECL
LVDS Output: Logic Level		LVDS

### 14.7.3 RF-SPLITTER

---

#### LO-Performance:

Input Power:	+4.5 ±0.5	dBm
Frequency Range:	50..800	MHz
Insertion Loss: LO_IN1 → LO_OUT1 (dual LO mode)	0 ±0.5	dB
Insertion Loss: LO_IN2 → LO_OUT1..10	0 ±0.5	dB
LO-Switch Isolation: LO_IN1 → LO_OUT1 (single LO mode)	> 20	dB
LO-Switch Isolation: LO_IN1 → LO_IN2 (dual LO mode)	> 20	dB
VSWR: all Ports	≤ 1.4	

#### LO2-Performance:

Input Power:	+4 ±0.5	dBm
Frequency:	720	MHz
Insertion Loss : LO2_IN → LO2_OUT1..10	0 ±0.5	dB
VSWR: all Ports	≤ 1.4	

#### Pulse Performance:

LVDS Input: Logic Level		LVDS
Pulse OUT: Logic Level	+5V	TTL
20MHz Clock OUT: Logic Level	+2/-2.5V	ECL
Pulse & Clock Test OUT: (Logic Level at 50Ω load)	1/10	TTL

## 14.8 Power Supply / Fuses

Both units are powered via their backplane connector from the user bus. For power supply status see 14.4.1. The units do not contain any fuses.

### 14.8.1 Backplane Connector

	z	a	b	c	d	e	f
1	GND	GND			GND	SAMPLE_INFO0	GND
2	GND		GND	SAMPLE_INFO3	SAMPLE_INFO2	SAMPLE_INFO1	GND
3	GND	GND		I2C_STATUS_INT~	GND	SAMPLE_INFO4	GND
4	GND	20MHZ_CLK_X <sup>a</sup>	GND	INTERLEAVE_INCR~			GND
5	GND	GND	20MHz_CLK_X~		GND	RGP_LO~	GND
6	GND		GND				GND
7	GND				GND	RGP_ADC~	GND
8	GND		GND			DWL_ENAB~	GND
9	GND				GND	RGP_RX~	GND
10	GND		GND				GND
11	GND				GND	RGP_HPPR~	GND

### Key Area

15	GND	SLOT(2)	SLOT(1)	SLOT(0)	GND		GND
16	GND	SLOT(3)	GND	I2C_SDA		GND	GND
17	GND		I2C_BUS_REQ~	I2C_SCL	GND		GND
18	GND		GND	I2C_2_SDA	I2C_2_SCL	GND	GND
19	GND				GND		GND
20	GND		GND			GND	GND
21	GND	P5V					GND
22	GND	P5V					GND
23	GND	P5V					GND
24	GND	P5V					GND
25	GND	P5V					GND

Table 14.3 User Bus Connector PULSE-SPLITTER

a. x = Slot-Nb.

	z	a	b	c	d	e	f
1	GND	SLOT4	SLOT3	SLOT2	SLOT1	SLOT0	GND
2	GND	I2C_SCL	I2C_SDA	I2C_BUS_REQ~	I2C_2_SCL	I2C_2_SDA	GND
3	GND	LOCAL_TX	LOCAL_RX	INTRA_STATUS_INT-	I2C_STATUS_INT-		GND
4	GND						GND
5	GND	GND	GND	GND	GND	GND	GND
6	GND	P12V	P12V	P12V	P12V	P12V	GND
7	GND						GND
8	GND	RESERVE(5)	RESERVE(4)	EMERGENCY_STOP-			GND
9	GND						GND
10	GND	P5V	P5V	P5V	P5V	P5V	GND
11	GND	GND	GND	GND	GND	GND	GND

## Key Area

15	GND	GND	GND	GND	GND	GND	GND
16	GND	P9V	P9V	P9V	P9V	P9V	GND
17	GND	N9V	N9V	N9V	N9V	N9V	GND
18	GND	GND	GND	GND	GND	GND	GND
19	GND						GND
20	GND						GND
21	GND	GND	GND	GND	GND	GND	GND
22	GND			SAMPLE_INFO(0)	DWL_ENAB~	RGP_LO~	GND
23	GND	GND	SAMPLE_INFO(2)	SAMPLE_INFO(1)	GND	RGP_ADC~	GND
24	GND	20MHZ_BACK_IN	GND	SAMPLE_INFO(3)	INTRLVE_INCR~	RGP_RX~	GND
25	GND	GND		SAMPLE_INFO(4)	GND	RGP_HPPR~	GND

Table 14.4 User Bus Connector RF-SPLITTER

# 15 AQS 2H TX

## 15.1 Function/Description

This AQS unit serves as a 80W power amplifier for deuterium. The unit is available in two frequency ranges for 300-400 and 500-1000MHz systems. This 2H-TX are intended to fit into the AQS/3 chassis in combination with a BLA2BB or in combination with external power amplifiers.

### Features:

- 6TE wide AQS unit
- Included Lock switch
- Blanking pulse direct from AQS backplane (source software switchable, for setting amplifier housing see "Default Values" on page 196)
- Overheat protection
- Software readable RF input detector
- Software readable RF output detector

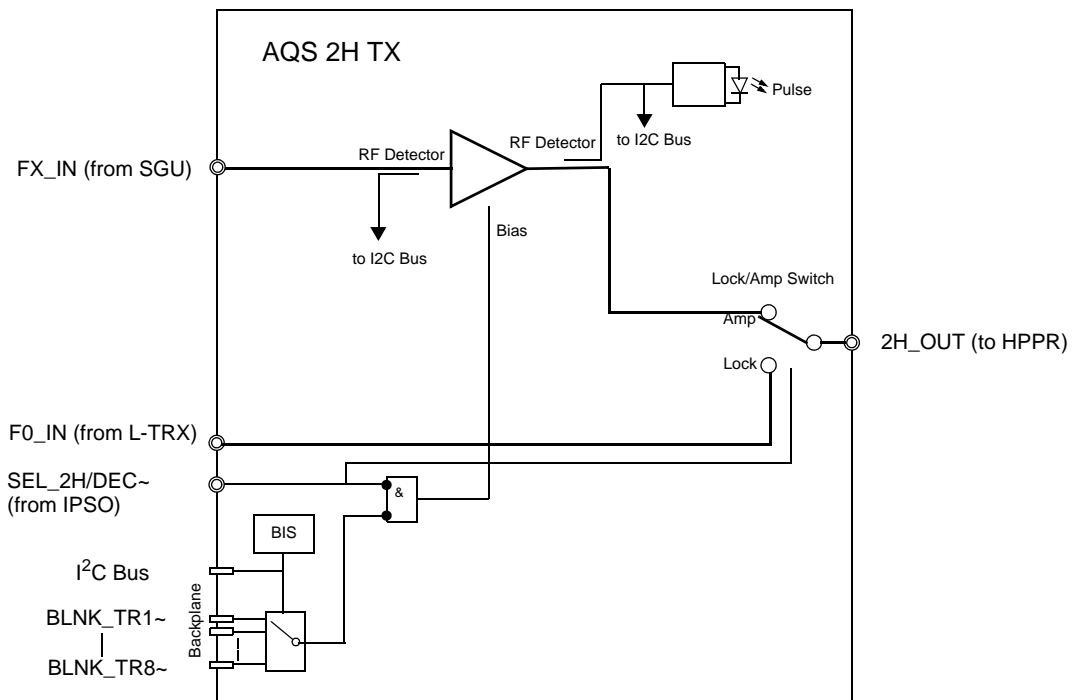

Figure 15.1 2H TX Blockdiagram

## 15.2 Front Panel

---

All RF input and output signals of the AQS 2H TX are connected via SMA connectors on the front panel.

Two LEDs indicate the correct DC power supply (28V) and an output RF pulse exceeding approximately 1W. The pulse LED will be on at least about one second even for a very short RF pulse.



Figure 15.2 2H-TX front panel

## 15.3 Part Numbers

---

Part	Description
Z103550	AQS 2H-TX BD 200-400
Z103551	AQS 2H-TX BD 500-1000

Table 15.1 2H-TX part numbers

## 15.4 Technical Data

---

	<b>Z103550</b> ECL $\geq$ 01 (200-400)	<b>Z103551</b> ECL $\geq$ 00 (500-1000)
Minimum pulsed Output Power	> 80 W	> 80W
1dB compression	80 W typ.	80 W typ.
RF Rise and Fall Time	< 100 ns	< 100 ns
Noise Figure	< 7 dB	< 7dB
Amplitude Droop	< $\pm 5\%$	< $\pm 5\%$
Blanking Delay	< 1 us	< 1 us

Table 15.2 2H-TX specifications





# 16 AQS 1 to 4 Router

## 16.1 Introduction

The AQS 1 to 4 Router Board is an optional unit for AVANCE III HD spectrometers. For automated work the RF signal routing has to be switched electronically. For configurations with two or more single amplifiers an external router is needed to be installed. This router conducts the RF signal from an SGU/3 channel to one of four amplifier inputs. In addition, the input signal can be extracted for the probe tuning. The location of the AQS 1 to 4 Router depends on the configuration. In principal it can be placed in any user slot 4..10. See "[AVANCE III HD Configurations](#)" for configurations with an optional 1 to 4 router.

## 16.2 Functions/Description

The AQS 1 to 4 Router switches an RF signal on INPUT to one of the four outputs and in addition to the output TUNE. The controlling of the switches is handled by the AQS Controller and transmitted by the I<sup>2</sup>C Bus.

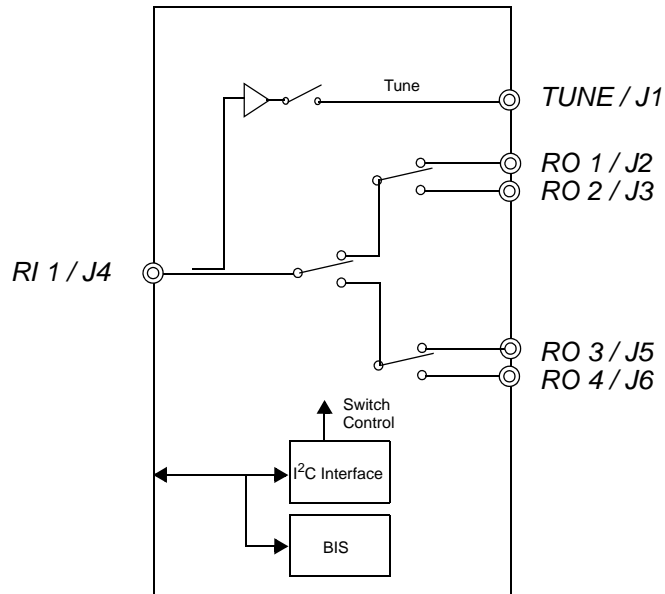

Figure 16.1 Block diagram of AQS 1 to 4 Router

### 16.2.1 Switching 1 to 4

Switching the input to one of the four outputs is done by ultra low loss devices, whereby two of them acting in series. One of the four outputs will always be connected with the RI 1 input.

## 16.2.2 Tune Signal

The tune signal is derived from the input signal. Therefore a small amount of power will be picked up and hereafter amplified again. The tune signal can be switched on and off. It will be activated only during probe head tuning.

## 16.2.3 Bus Interfaces

The AQS 1 to 4 Router Board is controlled by the I<sup>2</sup>C bus on the backplane. This bus is used to

- read the BIS data (Bruker information system)
- control of the switches and the signal at the tuning path

## 16.3 Front Panel Wiring / Display

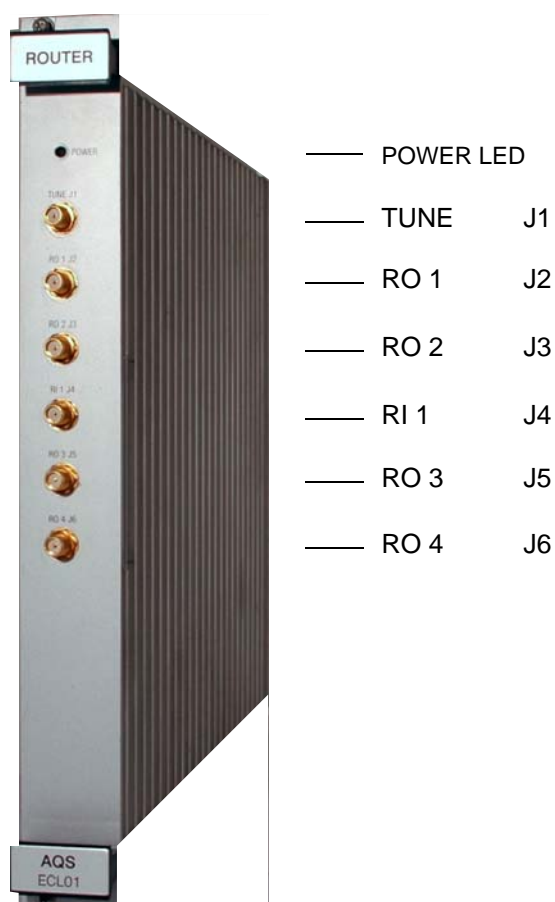

Figure 16.2 AQS 1 to 4 Router front panel

## **J1 TUNE**

The Signal has approx. the same RF level as on INPUT J4 and can deliver up to +4 dBm @ 50 W.

## **J2, J3, J5 and J6 RO\_X**

RF output to power amplifiers. The insertion loss is approx. 0.5 dB, and the isolation is  $\geq 45$ dB.

## **J4 RI 1**

Input of the RF signal to the 1 to 4 router and also to the tuning path. Source is RF OUT/ AUX OUT from SGU/3. The router can handle 1W RF, but for tuning the level has to be  $\leq +4$ dBm.

### **16.3.1 Power LED**

---

See ["Power Supply / Fuses"](#) on page 189.

## 16.4 Backplane Connector

	z	a	b	c	d	e	f
1	GND	GND	NC	NC	GND	NC	GND
2	GND	NC	GND	NC	NC	NC	GND
3	GND	GND	NC	NC	GND	NC	GND
4	GND	NC	GND	NC	NC	NC	GND
5	GND	GND	NC	NC	GND	NC	GND
6	GND	NC	GND	NC	NC	NC	GND
7	GND	NC	NC	NC	GND	NC	GND
8	GND	NC	GND	NC	NC	NC	GND
9	GND	NC	NC	NC	GND	NC	GND
10	GND	NC	GND	NC	NC	NC	GND
11	GND	NC	NC	NC	GND	NC	GND

### Key Area

15	GND	SLOT2	SLOT1	SLOT0	GND	NC	GND
16	GND	NC	GND	I2C_SDA	NC	GND	GND
17	GND	NC	NC	I2C_SCL	GND	NC	GND
18	GND	NC	GND	NC	NC	GND	GND
19	GND	NC	NC	NC	GND	NC	GND
20	GND	NC	GND	NC	NC	GND	GND
21	GND	P5V	NC	P9V	P9V	P9V	GND
22	GND	P5V	NC	N9V	N9V	N9V	GND
23	GND	P5V	P19V	NC	NC	P12V	GND
24	GND	P5V	P19V	NC	NC	P12V	GND
25	GND	P5V	P19V	NC	NC	P12V	GND

Table 16.1 Backplane Connector AQS 1 to 4 Router

## 16.5 Part Numbers and Cables

AQS 1 TO 4 ROUTER BOARD: P/N Z101247

The cables for RF connections are:

- CABLE KOAX ELSPEC 320 SMA/SMA P/N HZ03804
- CABLE KOAX ELSPEC 400 SMA/SMA P/N HZ10105/A

## 16.6 Troubleshooting / Unit replacement / Tips 'n' Tricks

---

If the power LED shows a permanently reduced brightness or does not light, then check the +5V, -5V, +9V and the +12V on board and the incoming voltages +9V, -9V, +12V on the main power supply.

The path from INPUT to the selected output can be tested by an ohm meter. Do not use the ohm meter to test isolation because the unselected outputs show a resistance of approx. 35  $\Omega$  to ground.

The AQS 1 to 4 Router Board can be replaced without necessary adjustments.

Unused outputs must not be terminated with 50 $\Omega$ .

## 16.7 Power Supply / Fuses

---

The AQS 1 to 4 Router uses P5V, P9V, N9V, P12V and P19V from the backplane (see [Table 16.1](#)). The power LED on the front panel is fully lightening when the AQS 1 to 4 Router is proper working. That means that all internal supply voltages are in the valid range.



# 17 AQS Controller

## 17.1 Introduction

---

The AQS controller is a part of the DRU firmware. It acts as a communication router for all RF boards inside the AQS Chassis. Furthermore the AQS controller hosts the firmware of all I2C boards, e.g. reference board, AQS internal amplifiers, routers and splitters.

In case of a multiple receiver system, only the DRU placed in Slot 1 will start the AQS Controller.

At power-up of the AQS Chassis, the AQS controller executes a rack scan and initializes all boards.

All boards can be accessed using the AQS service web.

## 17.2 AQS Address Mapping

---

Configuration and SBSB addresses can be found in the `../conf/instr/<curinst>` directory in the file `uxnmr.info` or by "[Identify Your Chassis Configuration](#)" (see [17.3](#)) using the AQS Service Web.

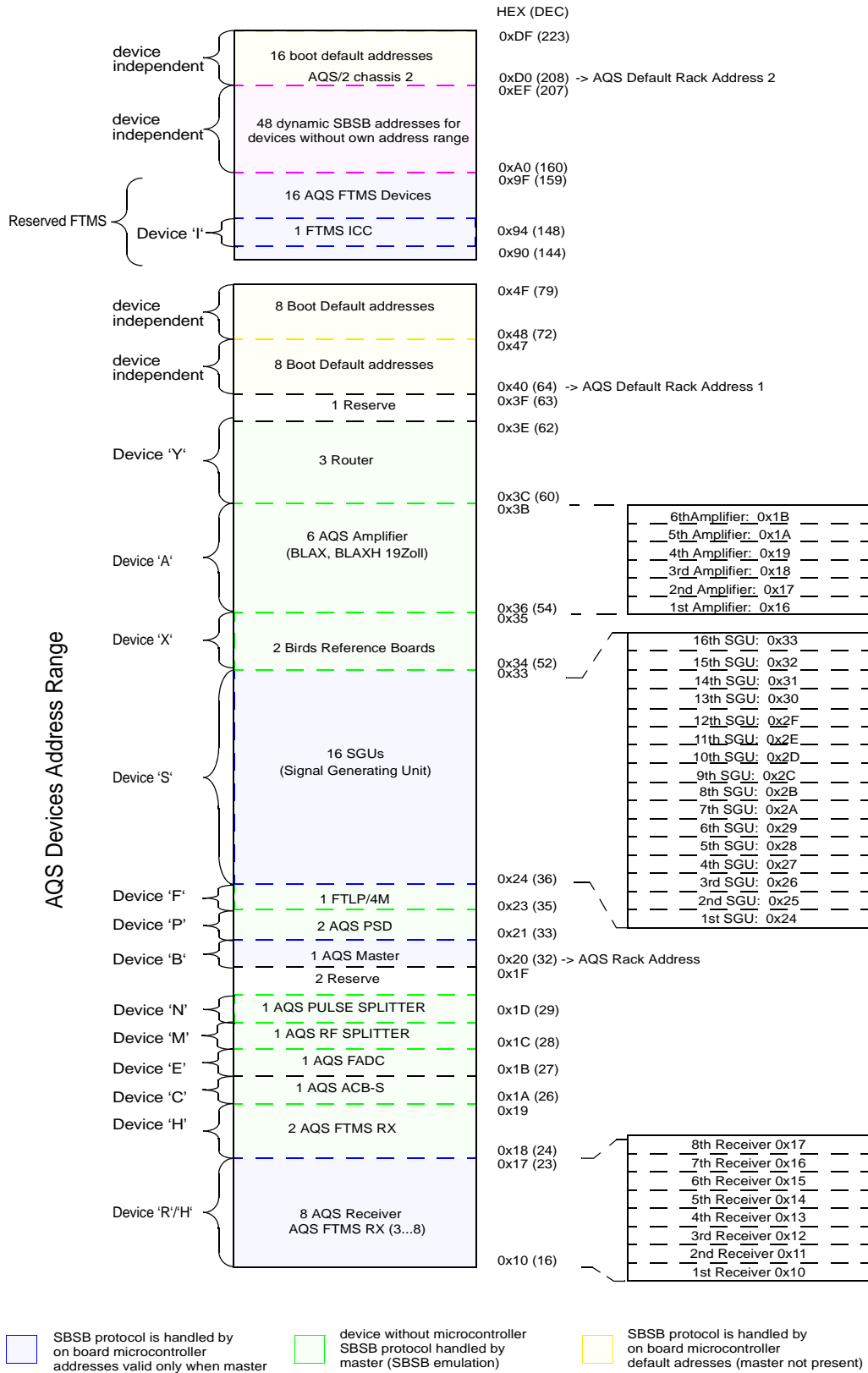

Figure 17.1 SBSB Addresses



## 17.3 Identify Your Chassis Configuration

Use the AQS service web to identify the AQS Chassis configuration.

### 17.3.1 AQS Service Web

The web page „AQS Control Overview“ („Hosted Devices“ → „AQS Overview“) shows all devices in the chassis controlled by the AQS Controller.

If there are internal preamplifiers (preamps directly connected to the DRU) then they will be shown on the web page „HPPR/2 Control Overview“ („Hosted Devices“ → „HPPR/2 Overview“).

### 17.3.2 AQS Board Type Codes

Board type codes are shown in [Table 17.1](#). Older Boards that are usually not in a IPSO based system are marked gray.

Board Type HEX (DEZ)	Board Description	BRUKER Part Number
0x00 (0)	SGU-C (frequency range 5..430MHz, PCB index C) SGU (frequency range 5..<643.45MHz, PCB index D)	Z003329 Z003642
0x01 (1)	Board not inserted	
0x02 (2)	AQS REFERENCE BOARD 400	Z003265
0x03 (3)	AQS REFERENCE BOARD RX22 400	Z003351
0x04 (4)	AQS 3-CHANNEL ROUTER BOARD	Z003624
0x05 (5)	AQS BLA2BB 150-60 dual amplifier 20-400MHz	W1345049
0x06 (6)	AQS BLAX300 single 300W X amplifier	W1345052
0x07 (7)	AQS Controller (AQS rack master)	
0x08 (8)	AQS FTLF/4M filter board	Z002812
0x09 (9)	AQS ACB standard	H9488
0x0A (10)	AQS PSD power supply distribution board	H9530
0x0B (11)	AQS RECEIVER BOARD RXAD FTMS	Z102501
0x0C (12)	AQS FTMS PSD power supply distribution board	A3142
0x0D (13)	AQS FADC	H9685
0x10 (14)	AQS SGU 400 (DRU is AQS Controller in AQS/2 PharmaScan / BioSpec)	Z003642
0x11 (17)	AQS SGU/2 400	Z103080
0x18 (24)	AQS SGU 600 (DRU is AQS Controller in AQS/2 PharmaScan / BioSpec)	Z003831
0x19 (25)	AQS SGU/2 600	Z103081

Table 17.1 AQS Board Type Identifier Codes

Board Type HEX (DEZ)	Board Description	BRUKER Part Number
0x20 (32)	AQS SGU 1000 (SGU-E, print index D, bis ECL02.00)	Z003330
0x28 (40)	AQS SGU 1000 (DRU is AQS Controller in AQS/2 PharmaScan / BioSpec)	Z003330
0x29 (41)	AQS SGU/2 1000	Z103082
0x30 (48)	AQS SGU-FTMS (ICR frequency range 5..XXXMHz, print index D)	Z003643
0x31 (49)	AQS SGU/2-FTMS (ICR frequency range 5..XXX-MHz, print index D)	Z103083
0x32 (50)	AQS SGU/3 600	Z117129
0x33 (51)	AQS SGU/3 1200	Z117130
0x34 (52)	AQS SGU/3 LF	Z117131
0x40 (64)	AQS RECEIVER BOARD RX600	Z003925
0x42 (66)	AQS RECEIVER BOARD RXAD600	Z102117
0x43 (67)	AQS RECEIVER BOARD RXAD/2 600	Z130588
0x50 (80)	AQS RECEIVER BOARD RX1000	Z003926
0x52 (82)	AQS RECEIVER BOARD RXAD1000	Z102118
0x53 (83)	AQS RECEIVER BOARD RXAD/2 1000	Z130589
0x60 (96)	AQS RECEIVER BOARD RX-BB (RX-E)	Z003689
0x61 (97)	AQS RECEIVER BOARD RX-BB (RX-BB)	Z003689
0x62 (98)	AQS RECEIVER BOARD RXAD-BB	Z102119
0x70 (112)	AQS RECEIVER BOARD RX400	Z003688
0x72 (117)	AQS RECEIVER BOARD RXAD400	Z102116
0x80 (128)	AQS DRU (DRU is not an SBSB Device)	Z100977
0x81 (129)	AQS DRU-E	Z102520
0x82 (130)	AQS LVDS TX	Z103710
0x90 (144)	AQS PSM-A POWER SUPPLY MODULE	Z121623
0x91 (145)	AQS PSM-D POWER SUPPLY MODULE	Z121625
0x92 (146)	AQS BLA200 42.5MHz	W1346829
0x93 (147)	AQS PSM-A2 POWER SUPPLY MODULE	Z133424
0x94 (148)	AQS INES PSM-BLA POWER SUPPLY	Z128045
0xC0 (192)	AQS REFERENCE BOARD 600	Z003936
0xC1 (193)	AQS REFERENCE BOARD 1000	Z003937
0xC2 (194)	AQS Reference Board with 22MHz IF output for RX22 (REF600-22)	Z003938
0xC3 (195)	AQS Reference Board with 22MHz IF output for RX22 (REF1000-22)	Z003939

Table 17.1 AQS Board Type Identifier Codes

Board Type HEX (DEZ)	Board Description	BRUKER Part Number
0xC4 (196)	AQS BLA2BB150/60 20-600 Dual Amplifier (IntG2 ab Ecl 08.00)	W1345072
0xC5 (197)	AQS 1 TO 4 ROUTER	Z101247
0xC6 (198)	AQS/2 Chassis	Z101618
0xC7 (199)	AQS 2H-TX BD 200-400	Z103550
0xC8 (200)	AQS 2H-TX BD 500-1000	Z103551
0xC9 (201)	AQS REFERENCE BOARD/2 1000	Z104236
0xCA (202)	AQS RF SPLITTER BOARD	Z104432
0xCB (203)	AQS PULSE SPLITTER BOARD	Z104431
0xCC (204)	AQS BLAXH300 300/50 500-600	W1345056
0xCD (205)	AQS PSD/2	H14107
0xCE (206)	AQS/2-M CHASSIS WIRED	Z103493
0xCF (207)	AQS PSD/3	H14109
0xD0 (208)	AVANCE CONSOLE NB-E WIRED	Z108356
0xD1 (209)	AQS/3 CHASSIS WIRED	Z106171
0xD2 (210)	AVANCE ACQ SYSTEM NANOBAY FTMS	Z105194
0xD3 (211)	AVANCE ACQ SYSTEM NANOBAY-N FTMS	Z113415
0xD4 (212)	AVANCE ACQ SYSTEM NANOBAY-E FTMS	Z114151
0xD5 (213)	AQS REFERENCE BOARD/2-M 1000	Z117593
0xD6 (214)	AQS REFERENCE BOARD/3 600	Z116985
0xD7 (215)	AVANCE CONSOLE NB-E WIRED V2 (AQS Nano-Bay / INES)	Z119572
0xD8 (216)	AQS/3 CHASSIS WIRED	Z106171
0xD9 (217)	AVANCE CONSOLE NB-E WIRED V3 (INES/3 AQS USER BUS)	Z126037 (Z128068)
0xF0 (240)	AQS ICC/2 BASIC NO ECD	-----
0xF1 (241)	AQS ICC/2 BASIC ECD (AQS ICC FTMS BASIC Z103801)	-----
0xF2 (242)	AQS ICC/2 EXTENDED NO ECD	-----
0xF3 (243)	AQS ICC FTMS (AQS ICC FTMS EXTENDED BOARD Z104099)	Z103800

Table 17.1 AQS Board Type Identifier Codes

## 17.4 New Configuration of the AQS Amplifiers

---

**i** Remember that the AQS Service Web is a hardware level debug tool. Improper operation may damage your hardware. Please read the following lines carefully.

According to the document "BIS Groups and Values" (Andreas Hünnebeck (AH), version 2.6 and higher), the amplifiers provide a housing information in its BIS that allows the software to determine an SBSB address.

Later versions of the amplifiers have this entry in their BIS. If an error message like

"no amplifier housing information in BIS, using default address" or

"multiple amplifier housing information in BIS, using default address"

is printed out you should read the following lines.

For future 3 channel configurations with internal AQS amplifiers, housing information must be programmed in the BIS.

### 17.4.1 Default Values

---

Default values in the amplifier BIS should be:

BLA2BB: Housing, Hsg = 1 (amplifier 1)

BLAX300: Housing, Hsg = 2 (amplifier 2)

AQS 2H-TX: Housing, Hsg = 3 (amplifier 3) for NanoBay console

Housing, Hsg = 8 (amplifier 8) for all other console types

To change the housing setting see

In a 2 channel AV with one BLA2BB without a housing entry, no error or warning message is given (backward compatibility to most used configurations). BLA2BB is amplifier 1.

For a 3 channel AV with BLA2BB and BLAX300, where both amplifier do not have a housing entry, warning messages are given and default values are set. These values can be modified using the UniTool with the BLA SBSB address.

Default SBSB addresses, when no housing is originally programmed

BLA2BB in slot 8: 0x36

BLA2BB in slot 8, BLAX300 in slot 6 (on the left side of BLA2BB):

BLA2BB: 0x36 (decimal 54)

BLAX300: 0x37 (decimal 55)

AQS 2H-TX in slot 9: 0x38 for NanoBay console

0x36 for all other console types

Check the addresses before changing any entry. This can be done with the AQS Service Web as follows:

Start a web browser and open the AQS Service Web page. (see [17.5](#))

Go to the „AQS Control Overview“ page („Hosted Devices“ → „AQS Overview“).

## 17.4.2 Adding Housing Setting (Via AQS Service Web)

---

1. Power up the AQS Chassis
2. Start a web browser and open the AQS Service Web page. (see [17.5](#))
3. Go to the „AQS Control Overview“ page („Hosted Devices“ → „AQS Overview“). There you can see a table entry for each amplifier. Follow the links to the device configuration page.
4. Select the housing and write the settings into the Amplifier.
5. Go back to the „AQS Control Overview“ page and perform a complete AQS-Rack scan or power the AQS Chassis down and up again.
6. Check the addresses of all amplifiers on the „AQS Control Overview“ page.
7. Remember that you have now changed the configuration and you have to perform a „Cl“.

## 17.5 AQS Service Web

The following AQS devices in the AQS Chassis are currently supported by the AQS Service Web:

- Chassis (AQS/2, AQS/2-M, AQS/3 and AQS/3+)
- AQS SGU/2 and AQS SGU/3
- AQS RXAD and AQS RXAD/2
- Reference Boards REF, REF/2 and REF/3
- Amplifiers (BLA2BB, BLAX300, BLA2HTX)
- Internal preamplifiers (HPPR/2)
- RF Splitter (in AQS/2-M Chassis)
- Pulse Splitter

When a DRU is AQS Controller the „DRU service web“ will become the „AQS service web“. You can get access to the „AQS Service Web“ like to a „DRU Service Web“ (see). The web pages have been tested with Microsoft Internet Explorer and Mozilla Firefox.

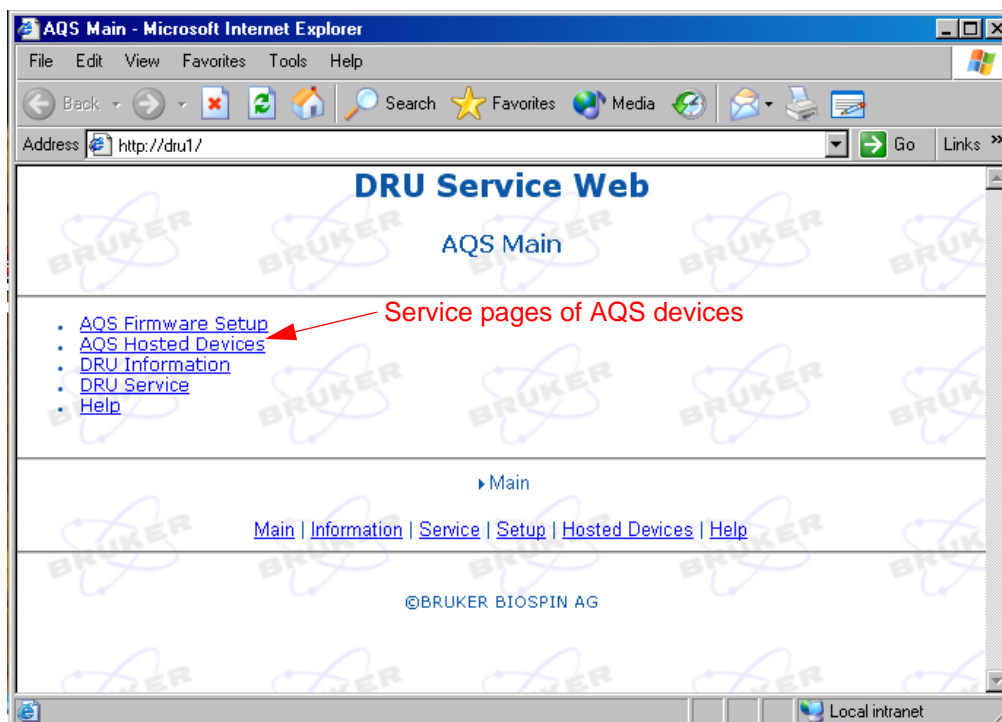

Figure 17.2 Access to the devices in the AQS Chassis



Figure 17.3 Hosted Devices





# 18 Transport, Packaging and Storage

## 18.1 Symbols on the Packaging

---

The following symbols are affixed to the packaging material. Always observe the symbols during transport and handling.

### Top



The arrow tips on the sign mark the top of the package. They must always point upwards; otherwise the content may be damaged.

### Fragile



Marks packages with fragile or sensitive contents. Handle the package with care; do not allow the package to fall and do not allow it to be impacted.

### Protect Against Moisture



Protect packages against moisture and keep dry.

## Component Sensitive to Electrostatic Charge



The packaging contains components which are sensitive to an electrostatic charge.

Only allow packaging to be opened by trained personnel.  
Establish potential equalisation before opening.

## 18.2 Inspection at Delivery

---

Upon receipt, immediately inspect the delivery for completeness and transport damage.

Proceed as follows in the event of externally apparent transport damage:

- Do not accept the delivery, or only accept it subject to reservation.
- Note the extent of the damage on the transport documentation or the shipper's delivery note.
- Initiate complaint procedures.

---

**i** Issue a complaint in respect to each defect immediately following detection. Damage compensation claims can only be asserted within the applicable complaint deadlines.

---

## 18.3 Packaging

---

### About Packaging

The individual packages are packaged in accordance with anticipated transport conditions. Only environmentally friendly materials have been used in the packaging.

The packaging is intended to protect the individual components from transport damage, corrosion and other damage prior to assembly. Therefore do not destroy the packaging and only remove it shortly before assembly.

### Handling Packaging Materials

Dispose of packaging material in accordance with the relevant applicable legal requirements and local regulations.

## 18.4 Storage

---

### Storage of the Packages

Store the packages under the following conditions:

- Do not store outdoors.
- Store in dry and dust-free conditions.
- Do not expose to aggressive media.
- Protect against direct sunlight.
- Avoid mechanical shocks.
- Storage temperature: 15 to 35 °C.
- Relative humidity: max. 60%.

If stored for longer than 3 months, regularly check the general condition of all parts and the packaging. If necessary, top-up or replace preservatives.



# 19 Installation and Initial Commissioning

**i** Installation, initial commissioning, retrofitting, repairs, adjustments or dismantling of the device must only be carried out by employees of the manufacturer or persons authorised by the manufacturer.

All the requirements concerning environment described in the technical specifications have to be met. To reduce the risk of electric shock and malfunctioning, install these devices in a temperature-controlled and humidity-controlled indoor area free of conductive contaminants.

## 19.1 Installation in Cabinet

The AQS mainframe must be installed at its designated position in the electronics cabinet to ensure proper air ventilation for the cooling fans. The position may vary in different cabinet types and sizes. The mainframe must be fixed with at least 4 screws to the cabinet.

### 19.1.1 Air Ventilation

At least one height unit (1HU) above and below the mainframe must be reserved for cooling air supply. Special air baffle plates may be used to support efficient ventilation. Typically the air intake is from the front and the exhaust towards the back of the cabinet.

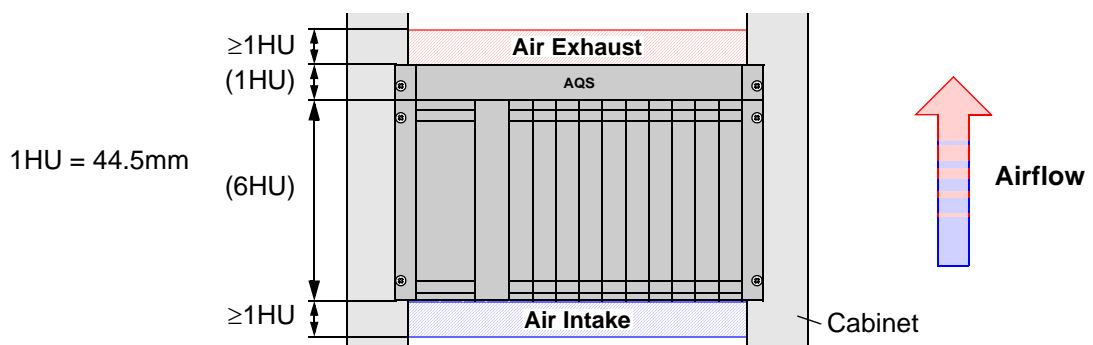

Figure 19.1 Cooling air supply to the mainframe

## 19.1.2 Power Cable

---

The power cable is included in the cabinet wiring. Make sure that cabling can not be a source of danger. All cables have to be connected before the AQS system is put into operation.

## 19.2 Initial Commissioning

---

The AQS system needs to be properly setup before the first power up. The setup mainly consists of rackcode and power-up delay settings described in the "[AVANCE III HD Configurations](#)" section of this manual.

### 19.2.1 AQS/2-M chassis Mains Selector

---

**i** Prior to the first power-up of the AQS/2-M mainframe, it must be ensured that the mains selector switch is in the correct position.

---

The AQS/2-M is safe to operate at all settings within an input voltage range of 208..230V~ ±10% according to IEC/EN 61010-1. However because the size of the linear power supply modules is designed for minimal power dissipation, the transformer input voltage should be matched to the mains voltage at the installation site. The input voltage ranges for optimal performance are as follows:

Input voltage range	Mains selector setting
187 .. 224 V~	208
202 .. 238 V~	220
212 .. 253 V~	230

= factory preset

Table 19.1 Mains selector settings for optimal performance

# 20 Maintenance

## 20.1 Safety

---

With the exception of the Field Exchangeable Units (FEUs), all servicing must be performed by qualified service personnel.

Before service, repair or shipment, the unit must be completely switched off and unplugged or disconnected and dismantled from its rack.

## 20.2 General

---

The AQS system can be expected to have a long and trouble-free life without any preventive maintenance. Environmental issues are essential in determining the reliability. The temperature and humidity have to be within specifications. The area around should be kept relatively clean and dust free.

## 20.3 Software

---

In case of problems, check for the newest official firmware releases for the AQS units (DRU, SGU/3 and RXAD/2) on the CH ftp server.

## 20.4 Cleaning

---

Cleaning the surface of the enclosure and/or front panel can be carried out by the owner, if the following instructions are adhered to:

1. Switch off the equipment and unplug the power cable.
2. Clean up the outside surface with a soft, lint-free cloth dampened in water.

---

**i** Use only water. Do not use any detergent or other cleaning solvents.

---

3. Let all surfaces completely dry before installing.
4. Connect all cables and power up.

## 20.5 Maintenance Work

### 20.5.1 Fan Tray Service Instructions

The fan tray removal and reassembly is essentially the same in all AQS chassis since the introduction of AQS/2. The following description uses pictures of the AQS/3+ chassis.

### 20.5.2 Fan Tray Removal

**⚠ WARNING**



**Electrical Hazard from Electrical Shock.**

A life threatening shock may result when the housing is opened when under power!

- ▶ Turn of the chassis with mains circuit breaker
- ▶ Disconnect the chassis from the mains power supply before opening.
- ▶ Be sure that the power supply cannot be reconnected without notice.

To remove the fan tray from the mainframe follow the steps exactly as described below:

1. Remove 4 screws on the rear side

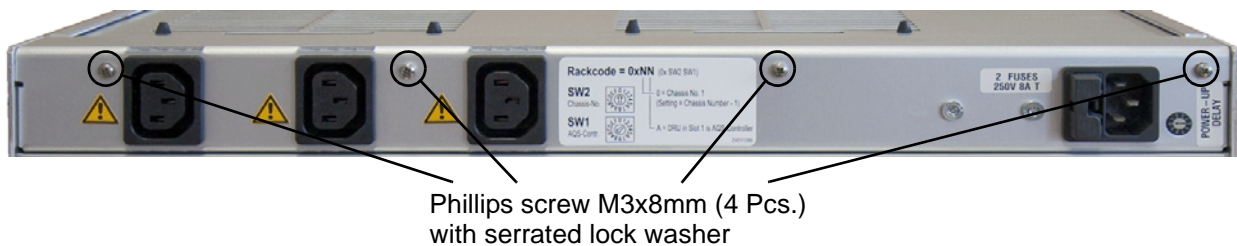

Figure 20.1 Fan Tray screws rear side

2. Remove 6 screws on the front side



Figure 20.2 Fan Tray screws front side



- Carefully pull the front panel away from the mainframe and place it towards the left side (dangling from the cable)

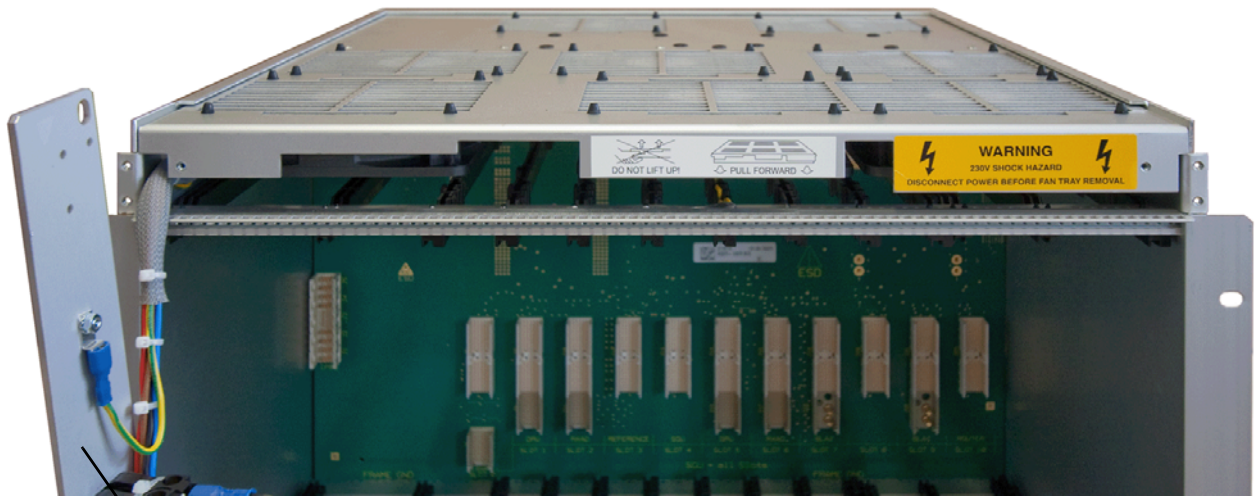

Front Panel with mains circuit breaker and cable

Figure 20.3 Front panel removal

- Remove the fan tray by pulling it gently towards the front

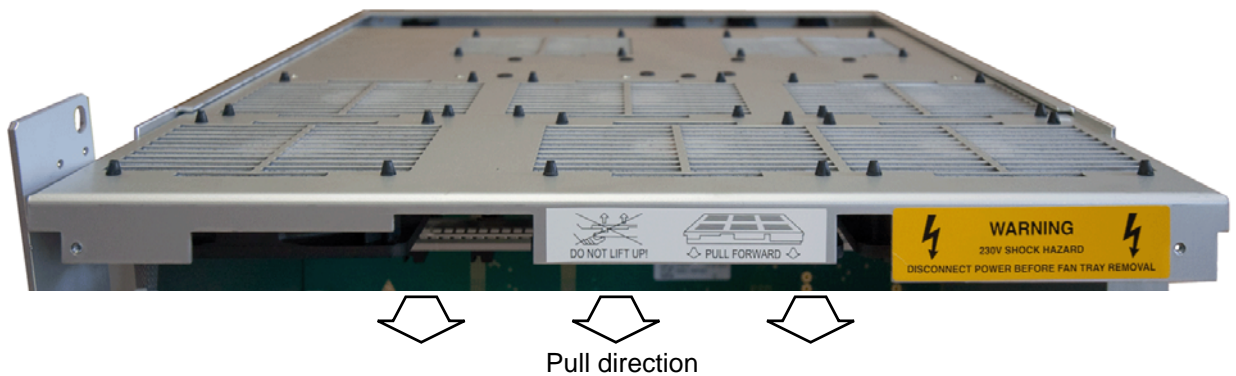

Figure 20.4 Fan Tray removal

### 20.5.3 Fan Tray Reassembly

To replace the fan tray in the mainframe follow the steps as described above in reverse order.

Make sure that:

- ▶ the fan tray sits flat on the guide rails on either side of the mainframe before final insertion
- ▶ no wires are squeezed in between the front panel and the fan tray
- ▶ all screws are secured and fastened properly (rear side screws with serrated lock washers)
- ▶ all fans turn freely after power up



# 21 Dismantling and Disposal

Following the end of its useful life, the device must be dismantled and disposed of in accordance with the environmental regulations.

- i** Installation, initial commissioning, retrofitting, repairs, adjustments or dismantling of the device must only be carried out by employees of the manufacturer or persons authorised by the manufacturer.

## 21.1 Safety

### Electrical System

#### **WARNING**



##### **Electrical hazard from electrical shock.**

A life threatening shock may result when the housing is open during operation.

- ▶ Disconnect the device from the electrical power supply before opening the device. Use a voltmeter to verify that the device is not under power!
- ▶ Be sure that the power supply cannot be reconnected without notice.

### Improper Dismanteling

#### **WARNING**



##### **Danger of injury due to improper dismantling!**

Stored residual energy, angular components, points and edges on and in the device or on the tools needed can cause injuries.

- ▶ Ensure sufficient space before starting work.
- ▶ Handle exposed, sharp-edged components with care.
- ▶ Dismantle the components properly.
- ▶ Secure components so that they cannot fall down or topple over.
- ▶ Consult the manufacturer if in doubt.

## 21.2 Dismantling

---

Before starting dismantling:

- Shut down the device and secure to prevent restarting.
- Physically disconnect the power supply from the device; discharge stored residual energy.
- Remove consumables, auxiliary materials and other processing materials and dispose of in accordance with the environmental regulations.
- Dismantle the device by following the installation instructions in reverse.

Clean assemblies and parts properly and dismantle in compliance with applicable local occupational safety and environmental protection regulations.

## 21.3 Disposal Instructions

---

If no return or disposal agreement has been made, send the dismantled components for recycling.

- Scrap metals.
- Send plastic elements for recycling.
- Sort and dispose of other components in accordance with their material composition.

### **NOTICE**

#### **Danger to the environment from incorrect handling of pollutants!**

Incorrect handling of pollutants, particularly incorrect waste disposal, may cause serious damage to the environment.

- ▶ Always observe the instructions below regarding handling and disposal of pollutants.
- ▶ Take the appropriate actions immediately if pollutants escape accidentally into the environment. If in doubt, inform the responsible municipal authorities about the damage and ask about the appropriate actions to be taken.

# A Appendix

## A.1 Warning Signs

---

### CAUTION

- Accident hazard from contact with hot surfaces on the unit. .... 74, 86
- Only connect AQS power supply units to chassis rear connectors. .... 71, 83
- This combination of symbol and signal word indicates a possibly hazardous situation which could result in minor or slight injury unless avoided. .... 14

### DANGER

- This combination of symbol and signal word indicates an immediately hazardous situation which could result in death or serious injury unless avoided. .. 13

### NOTICE

- Chassis restart timeout ..... 72
- Danger to the environment from incorrect handling of pollutants. .... 212
- This combination of symbol and signal word indicates a possibly hazardous situation which could result in damage to property or the environment unless avoided. .... 14

### WARNING

- Danger of injury due to improper dismantling! ..... 211
- Electrical hazard from electrical shock. .... 79, 208, 211
- Risk to life for unauthorized personnel due to hazards in the danger and working zone! ..... 19
- This combination of symbol and signal word indicates a potentially hazardous situation which could result in death or serious injury unless avoided. .... 14



## A.2 Figures

---

Figure 4.1	AQS/3+ and AQS/2-M chassis rating plate.....	22
Figure 5.1	Three Channel configuration for 200 – 600 MHz with AQS IPSO .....	24
Figure 5.2	AQS channel concept .....	26
Figure 5.3	AQS/3+ buses for a two channel system .....	28
Figure 5.4	Explanation of Dwell_Clk~ and RGP_ADC~.....	31
Figure 5.5	Pulse distribution of a two channel AVANCE III HD .....	35
Figure 5.6	RF Distribution .....	37
Figure 5.7	20 MHz Clock Distribution.....	37
Figure 6.1	AQS/3+ chassis rear view: rackcode switch location.....	39
Figure 6.2	AQS/3+ for 2 channel AVANCE III HD (internal IPSO).....	41
Figure 6.3	AQS/3+ for 2 to 6 channel AVANCE III HD (external IPSO).....	43
Figure 6.4	AQS/3+ for 2 RX/TX AVANCE III HD.....	45
Figure 6.5	LO2 splitter and AUX combiner .....	46
Figure 6.6	AQS/3+ for 2+2 RX/TX AVANCE III HD .....	49
Figure 6.7	20 MHz, LO2 and REF distribution .....	49
Figure 6.8	AQS/3+ for 2+2+2 RX/TX AVANCE III HD .....	53
Figure 6.9	AQS/3+ for 1 channel (RX/TX) PharmaScan AVANCE III HD.....	55
Figure 6.10	AQS/3+ for 2 channel (2-4TX/1RX) BioSpec AVANCE III HD.....	57
Figure 6.11	AQS/3+ for 2 channel BioSpec with mRX Option (2 TX / 4,8,16 RX) ..	61
Figure 6.12	AQS/3+ for 2 channel BioSpec with pTX Option (2+8TX/2RX) .....	64
Figure 6.13	20 MHz, LO2 and REF distribution .....	64
Figure 6.14	AQS/3+ for 2 channel Dual RX AVANCE III HD .....	67
Figure 7.1	AQS/3+ Chassis front view .....	70
Figure 7.2	AQS/3+ Chassis rear view .....	71
Figure 7.3	DRU Service Web: AQS Chassis Diagnostic.....	73
Figure 7.4	Safety Stop State Diagram .....	74
Figure 7.5	AQS/3+ AC Wiring .....	75
Figure 7.6	AQS/3+ User Bus (front view).....	76
Figure 7.7	AQS/3+User Bus (rear view without PSM-48V).....	76
Figure 7.8	Pulse switch function .....	77
Figure 7.9	DRU Service Web: AQS Chassis Setup .....	77
Figure 7.10	Fan Tray (Bottom view).....	78
Figure 7.11	PSM-48V removal from mainframe.....	80
Figure 8.1	AQS/2-M Chassis front view .....	82

Figure 8.2	AQS/2-M Chassis rear view .....	83
Figure 8.3	DRU Service Web: AQS Chassis Diagnostic .....	85
Figure 8.4	Safety Stop State Diagram.....	86
Figure 8.5	AQS/2-M AC Wiring .....	87
Figure 8.6	AQS/2 Transformer .....	88
Figure 8.7	AQS/2-M User Bus (front view).....	89
Figure 8.8	AQS/2-M User Bus (rear view).....	89
Figure 8.9	DRU Service Web: AQS Chassis Setup .....	90
Figure 8.10	Fan Tray (Bottom view).....	91
Figure 9.1	Power supply system overview .....	93
Figure 9.2	Overview PSM-48V .....	95
Figure 9.3	Overview PSM-A2.....	96
Figure 9.4	Front view BLNKTR~ OUT connector J3 / J4 .....	97
Figure 9.5	Overview PSM-D.....	98
Figure 9.6	View POWER SUPPLY DIGITAL.....	99
Figure 9.7	Overview PSM1 .....	100
Figure 9.8	Overview PSM5 .....	101
Figure 9.9	View PSM HPLNA.....	102
Figure 9.10	View PSM ADM.....	103
Figure 9.11	View PS BLA 28V .....	104
Figure 10.1	Block diagram of AQS Reference Board 3.....	106
Figure 10.2	Overall synchronisation of a 3 channel spectrometer with an AQS/3+ chassis .....	107
Figure 10.3	REF/3 front panel.....	108
Figure 10.4	Waveform of signal at J2.....	109
Figure 10.5	Waveform of signal at J3.....	110
Figure 10.6	Waveform of signal at J4.....	110
Figure 10.7	Waveform of signal at J5.....	111
Figure 10.8	Waveform of signal at J6...J9.....	111
Figure 11.1	RXAD/2 Block diagram .....	116
Figure 11.2	Circular Table: Mode of operation.....	118
Figure 11.3	AQS RXAD/2 front panel.....	121
Figure 11.4	AQS RXAD/2 web page .....	130
Figure 11.5	Erase all Entries of ACTUAL Frq .....	131
Figure 11.6	Example figure .....	132
Figure 11.7	Save Config into RXAD/2 Flash .....	133



Figure 11.8	Example of eda for RXAD/2 Quadrature Adjustment.....	134
Figure 11.9	Proposed setup for quad image adjustment .....	135
Figure 11.10	AQS RXAD/2 timing definitions.....	137
Figure 12.1	DRU Block diagram ,Digital Receiver'.....	143
Figure 12.2	AQS DRU-E and AQS DRU front-side view .....	144
Figure 13.1	LO Dasy-chain for channel 3 (channel 1 of SGU 2) configured as observe channel .....	152
Figure 13.2	NCO allocation.....	154
Figure 13.3	Channel 1 transmit, channel 2 observe .....	154
Figure 13.4	Channel 1 observe, channel 2 transmit .....	155
Figure 13.5	Channel 1 observe, channel 2 observe (dual receive mode).....	155
Figure 13.6	Pulse generation inside the SGU/3.....	156
Figure 13.7	SGU/3 front panel .....	157
Figure 13.8	Response 180° phase step.....	165
Figure 13.9	Response 90° step (45°/+135°) .....	166
Figure 14.1	Clock & RX-Pulse distribution .....	170
Figure 14.2	LO/LO2- Splitter .....	170
Figure 14.3	PULSE & RF-SPLITTER Wiring Diagram.....	171
Figure 14.4	AQS PULSE- & RF-SPLITTER boards front panel view.....	172
Figure 14.5	Pining J5/J6 Pulse Test Connector.....	174
Figure 14.6	Pulse Splitter Device and Diagnostic Status.....	175
Figure 14.7	RF-Splitter Device and Diagnostic Status.....	175
Figure 14.8	RF-Splitter Setup Window.....	176
Figure 14.9	RF-Splitter gain adjust DAC.....	177
Figure 15.1	2H TX Blockdiagram .....	181
Figure 15.2	2H-TX front panel.....	182
Figure 16.1	Block diagram of AQS 1 to 4 Router.....	185
Figure 16.2	AQS 1 to 4 Router front panel.....	186
Figure 17.1	SBSB Addresses .....	192
Figure 17.2	Access to the devices in the AQS Chassis .....	198
Figure 17.3	Hosted Devices.....	199
Figure 19.1	Cooling air supply to the mainframe .....	205
Figure 20.1	Fan Tray screws rear side .....	208
Figure 20.2	Fan Tray screws front side.....	208
Figure 20.3	Front panel removal .....	209
Figure 20.4	Fan Tray removal.....	209



## A.3 Tables

---

Table 2.1	Overview Installation and Operation Requirements for Personnel .....	16
Table 4.1	Product name and part number .....	21
Table 4.2	Technical data: General information .....	21
Table 4.3	Technical data: Electrical connection values.....	22
Table 4.4	Technical data: Environment conditions.....	22
Table 5.1	Data format of the 6 sample info words (5 bits each).....	32
Table 6.1	List of configurations .....	39
Table 6.2	Bill of material .....	40
Table 6.3	Bill of material .....	42
Table 6.4	Bill of material .....	44
Table 6.5	Bill of material: rack 1.....	47
Table 6.6	Bill of material: rack 2.....	48
Table 6.7	Bill of material: rack 1.....	50
Table 6.8	Bill of material: rack 2.....	51
Table 6.9	Bill of material: rack 3.....	52
Table 6.10	Bill of material .....	54
Table 6.11	Bill of material .....	56
Table 6.12	Bill of material: rack 1.....	58
Table 6.13	Bill of material: rack 2.....	59
Table 6.14	Bill of material: rack 3 (for 16 RX option only).....	60
Table 6.15	Bill of material: rack 1.....	62
Table 6.16	Bill of material: rack 2.....	63
Table 6.17	Bill of material .....	66
Table 7.1	Power-Up Delay.....	72
Table 7.2	Rackcode Switch Function.....	77
Table 8.1	Power-Up Delay.....	84
Table 8.2	Rackcode Switch Function.....	90
Table 9.1	AQS/3+ power supply part numbers .....	93
Table 9.2	AQS/2-M power supply part numbers .....	94
Table 9.3	Power supply module output specification (short form) .....	94
Table 9.4	Fuses PSM-A2.....	96
Table 9.5	Pinout HPPR connector J1 .....	97
Table 9.6	Pinout BLNKTR~ OUT connector J3 / J4.....	97
Table 9.7	Fuses PSM-D.....	98

Table 9.8	Fuses PSM1.....	100
Table 9.9	Fuses PSM5.....	101
Table 9.10	Pinout ADM POWER connector.....	102
Table 9.11	Fuses PSM ADM.....	103
Table 9.12	Pinout ADM POWER connector.....	103
Table 10.1	Backplane Connector REF/3.....	113
Table 11.1	Possible gain steps of the AQS RXAD/2.....	119
Table 11.2	LED States .....	122
Table 11.3	AQS RXAD error messages (Release AR) .....	125
Table 11.4	RXAD/2 backplane connector .....	138
Table 11.5	RXAD/2 extension connector .....	139
Table 12.1	IP Addresses for DRU.....	146
Table 12.2	DRU backplane connector .....	150
Table 12.3	DRU extension connector .....	150
Table 13.1	SGU/3 backplane connector .....	167
Table 13.2	SGU/3 extension connector .....	168
Table 14.1	PULSE SPLITTER LED Error Description .....	173
Table 14.2	RF-SPLITTER LED Error Description .....	173
Table 14.3	User Bus Connector PULSE-SPLITTER.....	179
Table 14.4	User Bus Connector RF-SPLITTER.....	180
Table 15.1	2H-TX part numbers.....	182
Table 15.2	2H-TX specifications .....	183
Table 16.1	Backplane Connector AQS 1 to 4 Router .....	188
Table 17.1	AQS Board Type Identifier Codes .....	193
Table 19.1	Mains selector settings for optimal performance.....	206



# Bruker your solution partner

Bruker provides a world class, market leading range of analytical solutions for your molecular and material research needs.

---

● **Bruker Corporation**

[info@bruker.com](mailto:info@bruker.com)  
[www.bruker.com](http://www.bruker.com)