

DNP-NMR

- DNP Control System Console
User Manual
Version 002



Copyright © by Bruker Corporation

All rights reserved. No part of this publication may be reproduced, stored in a retrieval system, or transmitted, in any form, or by any means without the prior consent of the publisher. Product names used are trademarks or registered trademarks of their respective holders.

This manual was written by

Reto Bader

© June 18, 2013: Bruker BioSpin AG

Fällanden, Switzerland

P/N: Z31943

DWG-Nr.: Z4D11336B

For further technical assistance on the DNP-NMR, please do not hesitate to contact your nearest BRUKER dealer or contact us directly at:

BRUKER BioSpin AG
Industriestrasse 26
CH-8117 Fällanden
Germany

Phone: + 41 44 825 9111
FAX: + 41 44 825 9696
E-mail: service@bruker.ch
Internet: www.bruker.com

1	About	7
1.1	This Manual.....	7
1.2	Policy Statement	7
1.3	Symbols and Conventions.....	7
	Other symbols on devices.....	9
2	Introduction.....	11
2.1	Limitation of Liability	11
2.2	Copyright.....	11
2.3	Warranty Terms.....	12
2.4	Before You Begin	12
2.5	Minimum Qualifications for Operating Personnel	12
2.6	The Bruker Service.....	12
2.7	Transport to Manufacturer.....	12
2.8	Manufacturer and Conformity.....	13
2.9	SI to US Conversion Factors.....	14
3	Safety.....	15
3.1	Intended Use	15
3.2	Owner's Responsibility	16
3.3	Personnel Requirements.....	18
	Qualifications.....	18
	Unauthorized Persons.....	19
	Instruction.....	19
3.4	Personal Protective Equipment	20
3.5	Position of the Safety Devices.....	20
3.6	Important Safety Considerations	21
3.7	Technically qualified personnel only.....	22
3.8	Basic Dangers.....	22
	General Workplace Dangers	23
4	Technical Data	25
4.1	General Information.....	25
4.2	Connection Values	25
4.3	Operating Conditions.....	25
5	Design and Function	27
5.1	Overview	27
5.2	Brief Description.....	27
	System Control Settings.....	29
6	Transport, Packaging and Storage	31

6.1	Symbols on the Packaging	31
6.2	Transport	31
6.3	Inspection at Delivery	32
6.4	Packaging.....	32
6.5	Storage	33
7	Installation and Initial Commissioning.....	35
8	Operation.....	37
8.1	Safety	37
8.2	Maintenance.....	37
8.3	General Operating Guidelines.....	38
9	Maintenance.....	39
9.1	Safety	39
9.2	Maintenance Schedule	40
	Maintenance.....	40
	Interlock Checks.....	42
10	Troubleshooting	43
10.1	General.....	43
10.2	Software	43
11	Dismantling and Disposal.....	45
11.1	Safety	45
11.2	Dismantling.....	45
11.3	Disposal Instructions	46

Contact

Manufacturer:

Bruker BioSpin AG
Industriestrasse 26
CH-8117 Fällanden
Switzerland
Phone: +41 44 825 9111
<http://www.bruker-biospin.com>

NMR Hotlines

Contact our NMR service centers.

Bruker BioSpin NMR provide dedicated hotlines and service centers, so that our specialists can respond as quickly as possible to all your service requests, applications questions, software or technical needs.

Please select the NMR service center or hotline you wish to contact from our list available at:

http://www.bruker-biospin.com/hotlines_nmr.html



1 About

1.1 This Manual

This manual is intended to be a reference guide for owners and operators. It provides detailed information about the user level maintenance and overall use of the Bruker device.

The figures shown in this manual are designed to be general and informative and may not represent the specific Bruker model, component or software/firmware version you are working with. Options and accessories may or may not be illustrated in each figure.

Carefully read all chapters before working on the device!

This manual describes parts and procedures relevant to the device version it is delivered with. For older hardware, please refer to the manual supplied at the time.

User interface, system messages, and manuals require a good understanding of the English language.

Warnings and danger alerts are printed in English and partially in French.

1.2 Policy Statement

It is the policy of Bruker to improve products as new techniques and components become available. Bruker reserves the right to change specifications at any time.

Every effort has been made to avoid errors in text and figure presentation in this publication. In order to produce useful and appropriate documentation, we welcome your comments on this publication. Support engineers are advised to regularly check with Bruker for updated information.

Bruker is committed to providing customers with inventive, high quality products and services that are environmentally sound.

1.3 Symbols and Conventions

Safety instructions in this manual are marked with symbols. The safety instructions are introduced using indicative words which express the extent of the hazard.

In order to avoid accidents, personal injury or damage to property, always observe safety instructions and proceed with care.



DANGER

This combination of symbol and signal word indicates an immediately hazardous situation which could result in death or serious injury unless avoided. On the equipment, the symbol implies also a danger and alerts the user. It is necessary for the user to refer to the manual prior to the use of marked items.



HIGH VOLTAGE

Throughout this manual, this symbol indicates necessary actions which imply a risk of death or being injured by high voltages. On the equipment, the symbol indicates dangerous voltages. Do not open a cover with this label!



WARNING

This combination of symbol and signal word indicates a potentially hazardous situation which could result in death or serious injury unless avoided.



CAUTION

This combination of symbol and signal word indicates a possibly hazardous situation which could result in minor or slight injury unless avoided.

NOTICE



This combination of symbol and signal word indicates a possibly hazardous situation which could result in damage to property or the environment unless avoided.



This symbol highlights useful tips and recommendations as well as information designed to ensure efficient and smooth operation.

1.3.1 Other symbols on devices

Table 1.1. Symbols used on the equipment or in this manual

	Hot device: On the equipment, the symbol indicates hot surfaces and alerts the user.
	Electrostatic sensitive device: Observe precautions for handling.
	Protective ground (earth) terminal: Used to identify any terminal which is connected to the external protective conductor for protection against electrical shock in case of fault.

2 Introduction

The DNP CONTROL SYSTEM CONSOLE is part of the BRUKER solid-state DNP-NMR system. It controls and supervises the unique high power microwave source (high power gyrotron) and its infrastructure (high voltage source, beam control, cooling, temperature control, hardware interlocks).

For simplicity, the DNP CONTROL SYSTEM CONSOLE is abbreviated with CONSOLE in the context of this manual.

The CONSOLE is controlled by software, therefore users do not need to open the cabinet. Exceptions from this general rule are described in this manual. In case of doubt please contact the Bruker service department for further assistance.

2.1 Limitation of Liability

All specifications and instructions in this manual have been compiled taking account of applicable standards and regulations, the current state of technology and the experience and insights we have gained over the years.

The manufacturer accepts no liability for damage due to:

- Failure to observe this manual
- Improper use
- Deployment of untrained personnel
- Unauthorized modifications
- Technical modifications
- Use of unauthorized spare parts

The actual scope of supply may differ from the explanations and depictions in this manual in the case of special designs, take-up of additional ordering options, or as a result of the latest technical modifications.

The undertakings agreed in the supply contract as well as the manufacturer's Terms and Conditions and Terms of Delivery and the legal regulations applicable at the time of conclusion of the contract shall apply.

2.2 Copyright

This manual is protected by copyright and intended solely for internal use.

This manual must not be made available to third parties, duplicated in any manner or form – whether in whole or in part – and the content must not be used and/or communicated, except for internal purposes, without the written consent of the manufacturer.

Violation of the copyright will result in legal action for damages. We reserve the right to assert further claims.

2.3 Warranty Terms

The warranty terms are included in the manufacturer's Terms and Conditions.

2.4 Before You Begin

This manual contains information and safety information that are necessary for the safe operation of the device.

Any user maintenance are to be accomplished using the information in this manual.

Consider all safety references!

2.5 Minimum Qualifications for Operating Personnel

Type of Task	Personnel	Training and Experience
Routine Use	Only personnel which have passed an appropriate training provided by Bruker and/or the owner of the DNP system is allowed to operate the CONSOLE.	Every user must read this manual before operating this CONSOLE. In addition Bruker instructs the owner of the system at installation, afterwards the owner is able to train further personnel to operate the DNP system.
Maintenance on User Level (described in this manual)		
Installation / Servicing	Bruker personnel only.	

Table 2.1 Overview Installation and Operation Requirements for Personnel

2.6 The Bruker Service

Our customer service division is available to provide technical information. See "[Contact](#)" on page 5 for contact details.

In addition, our employees are always interested in acquiring new information and experience gained from practical application; such information and experience may help improve our products.

2.7 Transport to Manufacturer

When parts of the CONSOLE must be returned to the manufacturer for a major repair, use the original packaging for transportation.

⚠ CAUTION

Service and repair must be done by Bruker service personnel.

2.8 Manufacturer and Conformity

Manufacturer

The individual units of the CONSOLE system are manufactured at different BRUKER production sites. The manufacturer can be identified by the part number prefix according to the following table.

Part No. Prefix	Z.....	H.....	W.....
Manufacturer Address	Bruker BioSpin AG Industriestr. 26 8117 Fällanden Switzerland	Bruker BioSpin GmbH Silberstreifen 4 76287 Rheinstetten Germany	Bruker BioSpin S.A. 34, rue de l'industrie 67166 Wissembourg Cédex France
Phone	+41 (44) 825 91 11	+49 (721) 5161 - 0	+33 (3) 88 73 68 00
Fax	+41 (44) 825 96 96	+49 (721) 5171 01	+33 (3) 88 73 68 79
E-Mail	sales@bruker-biospin.ch	nmr@bruker-biospin.de	bruker@bruker.fr
Internet	www.bruker.com		

Table 2.2 Manufacturer Identification

2.9 SI to US Conversion Factors

The following conversion factors can be/were used to convert the units used within this manual:

Measure	SI Units	U.S. Standard Units	Conversion Factor (rounded to nearest hundredth)
Linear	meter (m) centimeter (cm)	feet (ft.) inch (in.)	1 m = 3.28 ft. 1 m = 39.37 in. 1 cm = 0.394 in.
Area	square meter (m ²)	square foot (ft. ²)	1 m ² = 10.76 ft. ²
Volume	cubic meter (m ³) liter (l)	cubic foot (ft. ³) quart (qt.)	1 m ³ = 35.32 ft. ³ 1 l = 1.06 qt. (liquid)
Weight	kilogram (kg)	pounds (lbs.)	1 kg. = 2.21 lbs.
Pressure	bar	pounds/square inch (psi) atmosphere (ATM)	1 bar = 14.51 psi 1 bar = 0.99 ATM (standard)
Temperature	°C	°F	F = C × 1.8 + 32 C = (F - 32) / 1.8
Magnet Field Strength	Tesla (T)	Gauss (G)	1 T = 10 ⁴ G

Table 2.3 SI to U.S. Conversion Factors

3 Safety

This section provides an overview of all the main safety aspects involved in ensuring optimal personnel protection and safe operation.



DANGER

Non-compliance with the action guidelines and safety instructions contained in this manual may result in serious hazards.

3.1 Intended Use

The CONSOLE has been designed and constructed solely for the intended use described here. The CONSOLE is dedicated only for the Solid-State DNP-NMR Spectrometer of BRUKER

Intended use also includes compliance with all specifications in this manual.

Any use which exceeds or differs from the intended use shall be considered improper use.

No claims of any kind for damage will be entertained if such claims result from improper use.



WARNING

Do not use the DNP control system for a purpose other than the described “Intended Usage”.



DANGER

Operation of the CONSOLE in a manner not consistent with the instructions as described and recommended in this document may expose the user to unsafe conditions and may result in damage to the instrument. Service calls that arise from a failure to observe these recommendations are NOT covered by the instrument warranty

3.2 Owner's Responsibility

Owner

The term 'owner' refers to the person who himself operates the device for trade or commercial purposes, or who surrenders the device to a third party for use/application, and who bears the legal product liability for protecting the user, the personnel or third parties during the operation.

Owner's Obligations

The device is used in the industrial sector, universities and research laboratories. The owner of the device must therefore comply with statutory occupational safety requirements.

In addition to the safety instructions in this manual, the safety, accident prevention and environmental protection regulations governing the operating area of the device must be observed.

In this regard, the following requirements should be particularly observed:

- The owner must obtain information about the applicable occupational safety regulations, and - in the context of a risk assessment - must determine any additional dangers resulting from the specific working conditions at the usage location of the device. The owner must then implement this information in a set of operating instructions governing operation of the device.
- During the complete operating time of the device, the owner must assess whether the operating instructions issued comply with the current status of regulations, and must update the operating instructions if necessary.
- The owner must clearly lay down and specify responsibilities with respect to installation, operation, troubleshooting, maintenance and cleaning.



WARNING

The owner must ensure that all personnel dealing with the CONSOLE have read and understood this manual. In addition, the owner must provide personnel with training and hazards information at regular intervals.

- The owner must provide the personnel with the necessary protective equipment.

**! WARNING**

The owner must warrant that the CONSOLE is operated by trained and authorised personnel as well as all other work, as transportation, mounting, start-up, the installation, maintenance, cleaning, service, repair and shutdown, that is carried out on the device.

- All personnel who work with, or in the close proximity of the CONSOLE, need to be informed of all safety issues and emergency procedures as outlined in this user manual.
- The owner must document the information about all safety issues and emergency procedures in a laboratory SOP (Standard Operating Procedure). Routine briefings and briefings for new personnel must take place.
- The owner must ensure that new personnel must be supervised by experienced personnel. It is highly recommended to implement a company training program for new personnel on all aspects of product safety and operation.
- The owner must ensure that personnel is regularly informed of the potential hazards within the laboratory. This is all personnel that work in the area, but in particular laboratory personnel and external personnel such as cleaning and service personnel.
- The owner is responsible for taking measures to avoid inherent risks in the handling of dangerous substances, preventing industrial disease, and providing medical first aid in emergencies.
- The owner is responsible for providing facilities according to the local regulations for the prevention of industrial accidents and generally accepted safety regulations according to the rules of occupational medicine.
- All substances needed for operating and cleaning the device samples, solvents, cleaning agents, gases, etc. have to be handled with care and disposed of appropriately. All hints and warnings on storage containers must be read and adhered to.
- The owner must ensure that the work area is sufficiently illuminated to avoid reading errors and faulty operation.
- The owner must ensure that the laboratory is equipped with an oxygen warning device, in case the device is operated with nitrogen.

Furthermore, the owner is responsible for ensuring that the device is always in a technically faultless condition. Therefore, the following applies:

**! WARNING**

The owner must ensure that the maintenance intervals described in this manual are observed (chapter 9 "Maintenance").

WARNING



The maintenance and test procedures as listed below are part of the safety measures, therefore they are mandatory. Only Bruker service personnel is authorized to perform these procedures.

Annually:

- ▶ On site test of safety interlocks.

Every 10 years:

- ▶ Components that are part of the high voltage circuits need to be tested at Bruker manufacturing site.

The owner is responsible for ensuring that this maintenance is performed.

- The owner must ensure that all safety devices are regularly checked to ensure full functionality and completeness.

3.3 Personnel Requirements

3.3.1 Qualifications



DANGER

Only trained Bruker service personnel are allowed to mount, retrofit, repair, adjust and dismantle the unit!

3.3.2 Unauthorized Persons

⚠ WARNING



Risk to life for unauthorized personnel due to hazards in the danger and working zone!

Unauthorized personnel who do not meet the requirements described in this manual will not be familiar with the dangers in the working zone. Therefore, unauthorized persons face the risk of serious injury or death.

- ▶ Unauthorized persons must be kept away from the danger and working zone.
- ▶ If in doubt, address the persons in question and ask them to leave the danger and working zone.
- ▶ Stop operating the CONSOLE while unauthorized persons are in the danger and working zone.

3.3.3 Instruction

The personnel must receive regular instruction from the owner. The instruction must be documented to facilitate improved verification.

Date	Name	Type of Instruction	Instruction Provided By	Signature

Table 3.1

3.4 Personal Protective Equipment

While operating the CONSOLE no particular personal protective equipment is required.

3.5 Position of the Safety Devices

NOTICE

In the event of an emergency press button 1 or 2 as shown below.

This action separates the CONSOLE from mains supply, to restart the CONSOLE twist the emergency button.

These buttons must not be used to switch off the DNP Control System in regular operation. The main switch 3 must be used to separate the system from mains supply

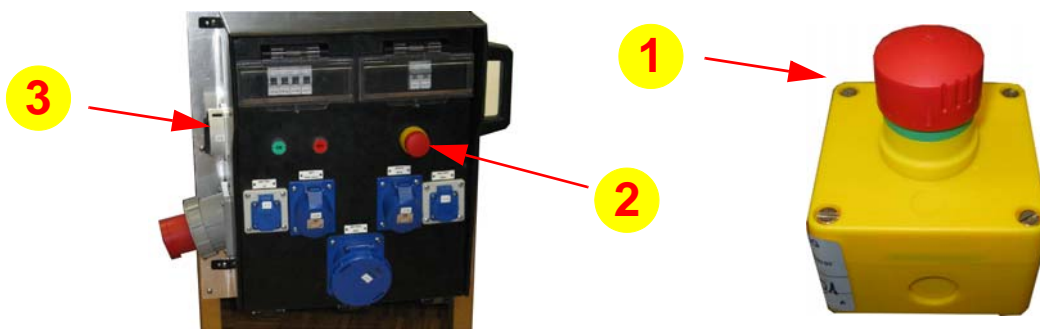

Figure 3.1 Switches 230V/50Hz Version (Europe)

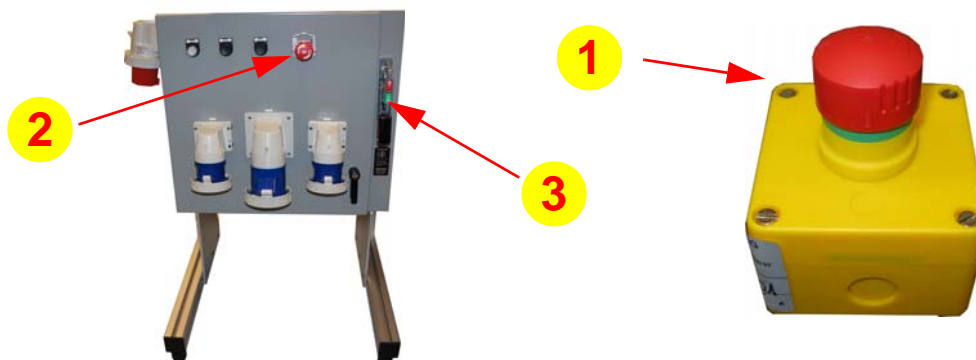

Figure 3.2 Switches 208V/60Hz Version (USA, Canada)

3.6 Important Safety Considerations

These safety instructions refer to the whole DNP control system including its subunits. The gyrotron operation requires a high voltage power supply with voltages up to 20kV.

HIGH VOLTAGE



Because of the high voltage levels (up to 20kV) it is essential to follow the instructions in this manual. In particular the high voltage cables and the ground connections must be free of damage.

Do not modify the DNP system, in particular do not loosen any cables

Do not open any units, there may be dangerous voltages present.

Do not touch any cable during lightning.

The CONSOLE can be damaged by inappropriate usage. In this case, it is necessary to check the equipment by the service before it can be used again.



! DANGER

Do not use the equipment and inform the service staff, if you are in doubt about the correct state of any component.

In the unlikely case of one of the following, stop using the equipment, interrupt the current supply, disclose this circumstance to the service staff and ask for instructions:

- The power cord, power plug or power supply are cracked, brittle or damaged
- Signs of excessive heat appear
- There is evidence or suspicion that a liquid has intruded into any enclosure
- Any device have been in contact with any liquid
- The CONSOLE has been damaged in any way
- The equipment does not work correctly
- The high voltage cable or the ground wire have been damaged.

DANGER



Do not try to service the equipment by yourself, in case of problems, please contact your nearest BRUKER office or representative.

As a general rule, servicing must be performed by BRUKER qualified service personnel. There are no DNP control system sub-assemblies that can be replaced or installed by the customer.

WARNING



Cryogen liquids (helium and nitrogen) mustn't be refilled if the system is active. Prior to filling liquids settle the system to state <OFF> and verify that the yellow light bulb (high voltage supply = active) is dark.

3.7 Technically qualified personnel only



WARNING

Service on electrical or other components must be performed only by a qualified Bruker Service Representative.

3.8 Basic Dangers

The following section specifies residual risks which may result from using the device and have been established by means of a risk assessment.

In order to minimize health hazards and avoid dangerous situations, follow the safety instructions specified here as well as in the following chapters of this manual.

3.8.1 General Workplace Dangers

Dirt and Scattered Objects

 **CAUTION****Danger of injury from tripping over dirt and scattered objects!**

Dirt and scattered objects may cause people to slip or trip. A fall may result in injuries.

- ▶ Always keep the work area clean.
- ▶ Remove objects which are no longer required from the work area and particularly from the floor.
- ▶ Indicate unavoidable hazards using marking tape.

4 Technical Data

4.1 General Information

Data	Value	Unit
Weight with subunits (typical configuration)	190	kg
Depth	92	cm
Width	69	cm
Height (without light tower)	130	cm
Height (with light tower)	204	cm

Table 4.1 Technical Data: General Information

4.2 Connection Values

Electrical

The CONSOLE is designed as a subsystem of the DNP spectrometer. For further environmental conditions outside the cabinet please refer to the appropriate BRUKER site planning guide of the spectrometer system.

4.3 Operating Conditions

Environment

Data	Value	Unit
Temperature range (operation)	17 to 25	°C
Temperature range (storage)	5 to 40	°C
Permissible altitude (above sea level)	< 2000	m
Relative humidity at 31 °C, maximum	< 80	%
Decreasing linear till relative humidity < 50% at 40 °C, maximum		

Table 4.2 Operating Environment

-
- i** Do not cover the ventilation slots on the front and back side of the CONSOLE. The minimum distance to any subject (e.g. wall) must be 50 cm in minimum.
-

5 Design and Function

5.1 Overview

The picture below shows the components of the DNP-NMR system. This user manual describes the DNP Control System Console. Gyrotron tube, magnet, transmission line and chillers are described in separate manuals.

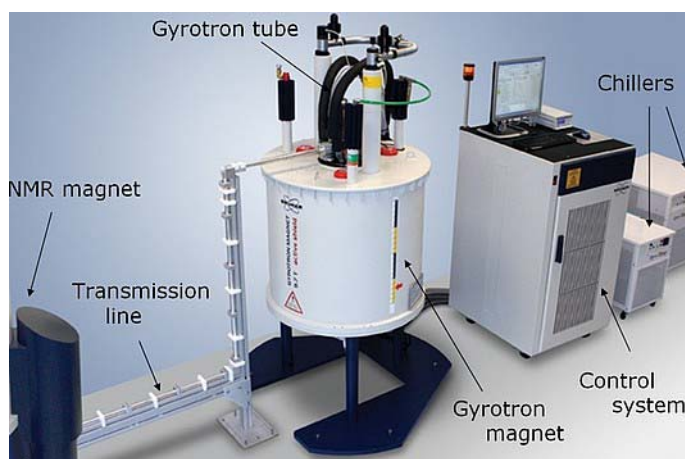

Figure 5.1 DNP-NMR system overview

5.2 Brief Description

This description is intended to give an overview of the Bruker DNP Control System Console. For further information please refer to the operating instructions of the DNP System.

The DNP Control System Console consists of:

- PXI Computer System including communication interfaces to sub-units and analog-to-digital converters
- High voltage power supply to accelerate electrons within the Gyrotron Tube
- Control Unit for supervision and real-time control
- Fast Protection Unit intended to protect the Gyrotron Tube
- Gyrotron Vacuum-Ion Pump high voltage power supply

All user actions are performed on the DNP Gyrotron Control Software (GCS) main panel. This interface consists of controls and indicators that are useful for the operator, additional information about the state of the DNP System is displayed for diagnostic purposes.

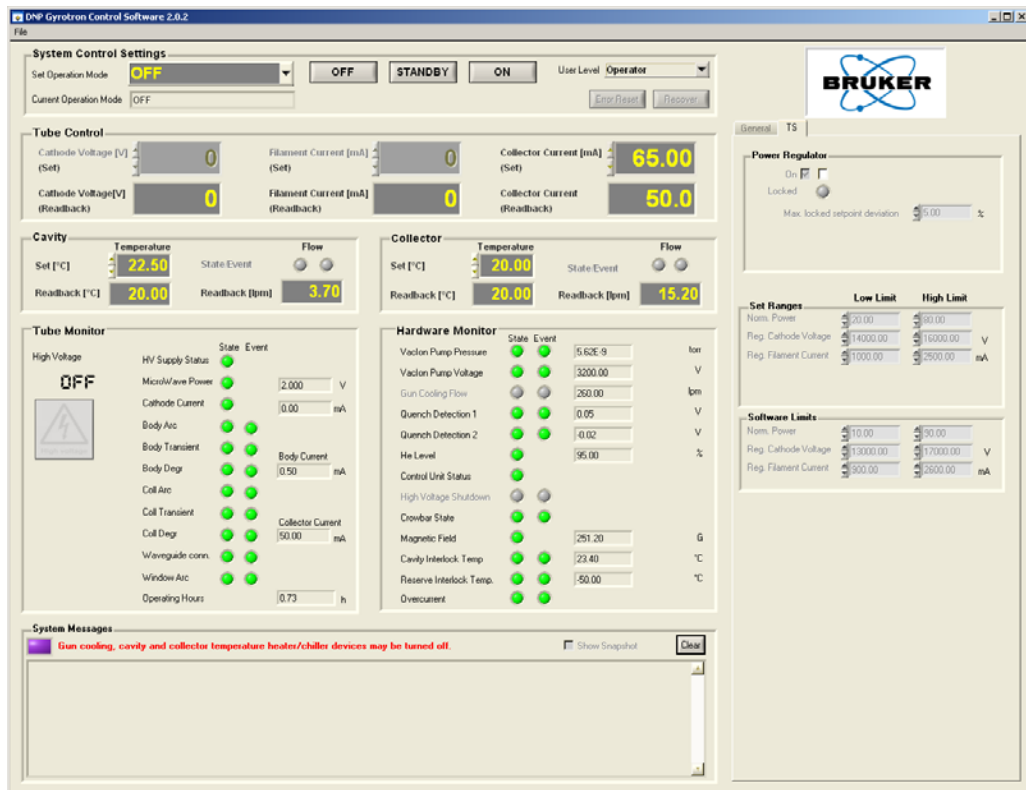

Figure 5.2 GCS Main Panel

Light Tower	Description
GREEN	The Gyrotron gun high voltage supply in STANDBY or ON condition.
YELLOW	The Gyrotron gun high voltage supply in ON condition, micro-wave generation process is or may be running.

Table 5.1 Light Tower description

5.2.1 System Control Settings

Operation Mode	Description
OFF	The system is down, only the vacion pump is running.
ON	Microwave generation process is active. The power level is stabilized by software.
STANDBY	This mode is intended to interrupt the microwave generation process for a limited amount of time. The high voltage is set to zero but the filament heater of the gun is active. The warm-up time from STANDBY to ON is significant shorter than the transition from OFF to STANDBY

Table 5.2 Set operation mode

User Level	Description
OPERATOR	Standard mode used by the operator, no password is required.
SERVICE	This access level is preserved to Bruker service staff, it is intended for setup and maintenance purposes.
DEVELOPER	Only staff from the Bruker development department use this access level. Special knowledge about the system is required to prevent from injuries or gyrotron damage.

Table 5.3 User level

Tube Control	The microwave power is stabilized by a regulator. The operator is able to select an appropriate power level by settling the „Collector Current“. The collector current is proportional to the microwave power, please refer to the operating instructions of the DNP System to get appropriate values.
Cavity	The microwave frequency is controlled by the cavity temperature. This temperature is stabilized to $\pm 0.2^{\circ}\text{C}$.
Collector	The collector temperature is settled in this section. The stability of this temperature is $\pm 1.0^{\circ}\text{C}$.
Tube / Hardware Monitor	The gyrotron tube is supervised by the control system. As long as the system is up and running without any problems all „State/Event“- indicators light green. In the case of an error (indicator(s) light(s) red or yellow) please contact Bruker service staff for further assistance.
System Messages	This section is used to show miscellaneous information about the system to the user. In the case of an unexpected behavioral of the DNP system it may be helpful to consider this message window.

Table 5.4 User interface sections

6 Transport, Packaging and Storage

6.1 Symbols on the Packaging

The following symbols are affixed to the packaging material. Always observe the symbols during transport and handling.

Top



The arrow tips on the sign mark the top of the package. They must always point upwards; otherwise the content may be damaged.

Fragile



Marks packages with fragile or sensitive contents. Handle the package with care; do not allow the package to fall and do not allow it to be impacted.

Protect Against Moisture



Protect packages against moisture and keep dry.

6.2 Transport

The DNP control system console contains a large amount of sensitive parts and assemblies, therefore it must be handled with care and protected against mechanical shock.



⚠ WARNING

Move the console slowly to prevent from cant over.

6.3 Inspection at Delivery

Upon receipt, immediately inspect the delivery for completeness and transport damage. In particular review the Tiltwatch™ and Shockwatch™ labels.

Proceed as follows in the event of externally apparent transport damage:

- Do not accept the delivery, or only accept it subject to reservation.
- Note the extent of the damage on the transport documentation or the shipper's delivery note.
- Initiate complaint procedures.

i Issue a complaint in respect to each defect immediately following detection. Damage compensation claims can only be asserted within the applicable complaint deadlines.

6.4 Packaging

About Packaging

The individual packages are packaged in accordance with anticipated transport conditions. Only environmentally friendly materials have been used in the packaging.

The packaging is intended to protect the individual components from transport damage, corrosion and other damage prior to assembly. Therefore do not destroy the packaging and only remove it shortly before assembly.

Handling Packaging Materials

Dispose of packaging material in accordance with the relevant applicable legal requirements and local regulations.

6.5 Storage

Storage of the Packages

Store the packages under the following conditions:

- Do not store outdoors.
- Store in dry and dust-free conditions.
- Do not expose to aggressive media.
- Protect against direct sunlight.
- Avoid mechanical shocks.
- Storage temperature: 5 to 40 °C.
- Relative humidity: max. 80%.

If stored for longer than 3 months, regularly check the general condition of all parts and the packaging. If necessary, top-up or replace preservatives.

7 Installation and Initial Commissioning



WARNING

Installation, initial commissioning, retrofitting, repairs, adjustments or dismantling of the device must only be carried out by employees of the manufacturer.

8 Operation

8.1 Safety

Improper Operation

WARNING



Danger of injury from improper operation!

Improper operation can result in serious injury and significant damage to property.

- ▶ Carry out all operating steps in accordance with the specifications and instructions in this manual.

Before starting work, ensure that

- ▶ All covers and safety devices are installed and functioning properly.
- ▶ While operating the system (ON, STANDBY according to chapter [8.3 "General Operating Guidelines"](#)) no manipulations e.g. refilling helium or nitrogen are allowed.



WARNING

Never disable or bypass safety devices during operation!

Take care of cables and wires!

8.2 Maintenance

Information about maintenance procedures which need to be performed by operator are available in chapter [9 "Maintenance"](#)

8.3 General Operating Guidelines

The DNP Control System may be easily operated by using the DNP Gyrotron Control Software which provides the modes as described below. It is not recommended to perform other actions without previously contacting Bruker service personnel.

Operation Mode	Description
OFF	If the system is not in use either currently or within the next 2h this mode should be selected. In OFF state microwave generation is disabled but the vacuum ion pump is active to sustain the high quality vacuum inside the gyrotron tube.
ON	Moving to ON state starts the microwave generation process. Parameters like microwave power, frequency, collector temperature are controlled and stabilized by software regulators.
STANDBY	In the case of a short interrupt of generating microwaves (< 2h) the system may be set into STANDBY mode, the microwave generation process is stopped but gyrotron gun heater stays active, this leads to shorter warm-up delays compared to the transition from OFF to ON. It is not recommended using this mode excessively.

Table 8.1 Set operation mode

WARNING



The indicators on the user interface show the current system status as detected by software and as such, are intended to be used only as a guide.

Always refer to the safety instructions in this manual to prevent from injuries or death

9 Maintenance

9.1 Safety



WARNING

Do not modify the system, in particular wiring changes are not permitted.
Stick strictly to the maintenance instructions described in this document.

Improperly Performed Maintenance



WARNING

Danger of injury due to improperly performed maintenance!

- ▶ Do not clean the system except monitor, mouse, keyboard, and surface of the console.

Improperly performed maintenance may lead to serious injury and significant material damage.

- ▶ Keep the assembly area tidy and clean! Loose components and tools lying around or on top of each other may lead to accidents.
- ▶ When reinstalling previously removed components, make sure that the components are mounted properly, all fixing elements are reinstalled, and all screws are tightened to torque.

Before putting the device back into operation:

- ▶ Make sure that all maintenance work has been performed and completed following the instructions and information provided in this manual.
- ▶ Make sure that no persons are still in the danger zone of the device.
- ▶ Make sure that all covers and safety devices have been installed and function properly.

Securing to Prevent Restart



⚠ WARNING

Danger to life from an unauthorized restart!

In the event of an unauthorized restart of the power supply during maintenance, there is a danger of serious injuries or death for persons in the danger zone.

- ▶ Switch off all power supplies before starting work and make sure they cannot be switched on again.

9.2 Maintenance Schedule

The sections below describe the maintenance work required to ensure optimal and smooth operation of the device.

If increased wear is found during regular checks, the required maintenance intervals should be shortened in accordance with the actual wear occurrences. Contact Bruker in the event of questions regarding maintenance work and intervals (see ["Contact"](#) on page 5).

9.2.1 Maintenance

Preparation

1. Shut down and switch off the computer
2. Separate the Control System from mains supply by switch 1 according to the figure below.

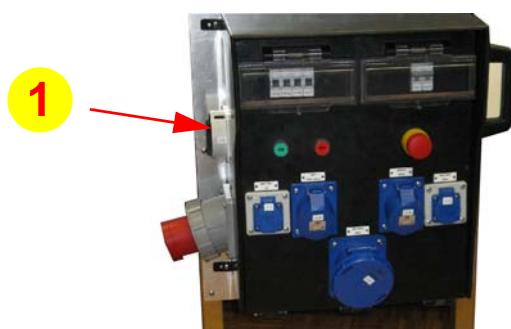

230V/50Hz Version (Europe)



208V/60Hz Version (USA, Canada)

Figure 9.1 Main Switch

Maintenance Procedures

In the case of an error, please contact the Bruker Service Department.

Procedure	Interval	Notes
Air filter inspection/cleaning	6 month	<ul style="list-style-type: none"> Open the back door of the console to get access to the rear side of the computer. Dirty filters have to be removed (screw 1) and cleaned with compressed air. <p>Figure 9.2 Rear view</p>  <p>filter fleece screw 1</p> <ul style="list-style-type: none"> Remount filter fleece and close the back door of the console
PXI inspection	1 month	<ul style="list-style-type: none"> Visual inspection of the PXI main power switch - the LED of the button must light green. <p>Figure 9.3 Front view</p>  <p>PXI Main Power Switch</p>
Cable inspection	1 month	<ul style="list-style-type: none"> Visual inspection of the external cables (in particular high voltage and ground wires)
Hose inspection	1 month	<ul style="list-style-type: none"> Visual inspection of the water hoses. They have to be tight (no water on the floor or somewhere else)

Table 9.1 Maintenance schedule

Completion

1. Connect the Control System to mains supply by switch 1 according to the figure below.
2. Switch on and restart the computer

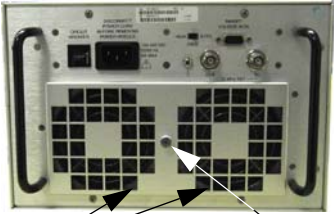
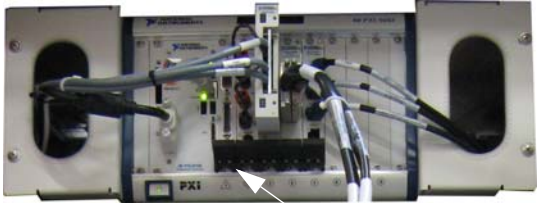
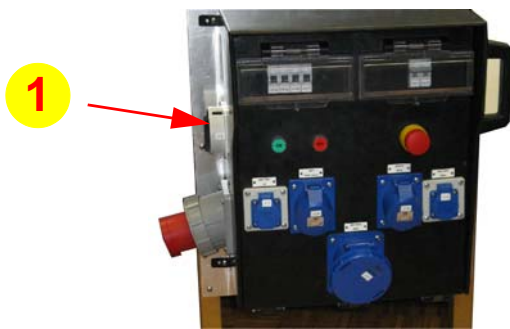

230V/50Hz Version (Europe)



208V/60Hz Version (USA, Canada)

Figure 9.4 Main Switch

9.2.2 Interlock Checks

Interlock test procedure must be done periodically by a Bruker service engineer (please look at [3.2 "Owner's Responsibility"](#)).

10 Troubleshooting

10.1 General

The following chapter describes the possible causes of faults, and the work required to rectify them.

If a failure occurs during operation, the system interrupts the current procedure.

On the user interface screen an error message, i. e. a code number with a corresponding text, is displayed. Take down the code number and complete error message.

With this information contact the customer service. See ["Contact" on page 5](#) for contact details.

Contact the manufacturer in the event of faults which cannot be rectified in accordance with the instructions below.

10.2 Software

The DNP Control System logs all information in a file. With the help of this file Bruker customer service can diagnose the system. In case of troubleshooting as a result of an unknown error, Bruker customer service may ask you to send the log files and the system data. From these files the customer service can obtain additional debugging information. These files do not contain any information about your company, samples or spectra. Bruker will not give any information to a third party.

Information exchange is accomplished via a USB memory stick which has sufficient free space and is FAT32 formatted.

11 Dismantling and Disposal

Following the end of its useful life, the device must be dismantled and disposed of in accordance with the environmental regulations.

11.1 Safety

Electrical System



WARNING

Electrical hazard from electrical shock!

A life threatening shock may result when the housing is open during operation.

- ▶ Disconnect the device from the electrical power supply before opening the device.
- ▶ Be sure that the power supply cannot be reconnected without notice.

Improper Dismantling



WARNING

Danger of injury due to improper dismantling!

Stored residual energy, angular components, points and edges on and in the device or on the tools needed can cause injuries.

- ▶ Ensure sufficient space before starting work.
- ▶ Handle exposed, sharp-edged components with care.
- ▶ Dismantle the components properly.
- ▶ Secure components so that they cannot fall down or topple over.
- ▶ Consult the manufacturer if in doubt.

11.2 Dismantling

Before starting dismantling:

- Shut down the device and secure to prevent restarting.

- Physically disconnect the power supply from the device; wait 10 minutes minimum before going ahead.

Clean assemblies and parts properly and dismantle in compliance with applicable local occupational safety and environmental protection regulations.

11.3 Disposal Instructions

If no return or disposal agreement has been made, send the dismantled components for recycling.

- Scrap metals.
- Send plastic elements for recycling.
- Sort and dispose of other components in accordance with their material composition.

NOTICE

Danger to the environment from incorrect handling of pollutants!

Incorrect handling of pollutants, particularly incorrect waste disposal, may cause serious damage to the environment.

- ▶ Always observe the instructions below regarding handling and disposal of pollutants.
- ▶ Take the appropriate actions immediately if pollutants escape accidentally into the environment. If in doubt, inform the responsible municipal authorities about the damage and ask about the appropriate actions to be taken.





Bruker Corporation

info@bruker.com
www.bruker.com

Order No: Z31950