

Bruker BioSpin

GRASI-1.0

Gradient and Shim Interface Unit
User Manual

Version 001

think forward

NMR Spectroscopy

The information in this manual may be altered without notice.

BRUKER BIOSPIN accepts no responsibility for actions taken as a result of use of this manual. BRUKER BIOSPIN accepts no liability for any mistakes contained in the manual, leading to coincidental damage, whether during installation or operation of the instrument. Unauthorised reproduction of manual contents, without written permission from the publishers, or translation into an other language, either the entire manual or a part of it, is forbidden.

This manual describes the units as they are at the date of printing. On request, the manufacturer shall supply circuit diagrams, lists of components, descriptions, calibrating instructions and any other information for use by qualified personnel of the user, in charge of repairing the parts of the unit which have been stated by the manufacturer to be "repairable". Such supply shall in no event constitute permission to modify or repair the units or approval of the same.

All rights reserved for the units, circuits, processes and appellations mentioned herein.

This unit is not designed for any type of use which is not specifically described in this manual. Such use may be hazardous.

This manual was written by

[Eric Schatz and Vincent Brosseau](#)

This manual was edited and desktop published by

[Dominique Wurtz](#)

© September 29, 2009: Bruker BioSpin

Wissembourg, France

P/N: Z31905

DWG-Nr: Z4D11081

For further technical assistance on the GRASI-1.0 unit, please do not hesitate to contact your nearest BRUKER dealer or contact us directly at:

BRUKER BioSpin
34 rue de l'Industrie
F-67166 Wissembourg Cedex
France

Phone: + 33 388 066 000
Fax: + 33 388 736 820
Email: support-rmn@bruker.fr
Internet: www.bruker.com

Contents

	Contents	3
1	Introduction	5
2	Safety	7
2.1	Instructions	7
2.2	Labels	7
	Identifying plate	7
	Manufacturer's nameplate	8
	Warning signs	9
3	Installation	11
3.1	Initial inspection	11
	Mechanical check	11
	Claim for damage	11
	Reshipment and repackaging requirements	11
	Environment requirements	12
3.2	Installation requirements	12
	Bench operation	12
3.3	System check	12
3.4	Initial turn on procedure	12
4	Operation	13
4.1	General fonctions	13
	Amplifier selection	14
	Coil code selection	14
	Powering up	14
	Initialisation process	14
	Calibration	14
4.2	Error messages	15
5	Technical description	17
5.1	General description	17
5.2	Power requirements	17
	Main characteristics	17
5.3	Front panel connectors	18
5.4	Front panel indicators	19
5.5	Front panel buttons	19
5.6	Rear panel connectors	19
	Gradient Coil Code connector from Gradient set	19
	Status and Command connector from GPSCU	20
	Status and Command connector to amplifier	21

	Interlock Binder connector	22
	Coil Code Binder connector	22
	B0 Output Twinaxe connector	23
	Interface Connector Ethernet 10/100	23
5.7	Rear panel overview	24
6	<i>Servicing the GRASI</i>	25
6.1	Accessing the GRASI unit	25
6.2	Sub Toolbar Information	26
	Device Information	26
	Device Status	27
	BIS Content	28
6.3	Sub Toolbar Basic Operations	29
	Reset Error	29
6.4	Sub Toolbar Maintenance	30
	Settings Update	30
	Firmware Update	31
	Device Reset	32
6.5	Sub Toolbar Diagnostics	33
	Event Log	33
7	<i>Specification</i>	35
7.1	General specifications	35
	<i>Figures</i>	37
	<i>Tables</i>	39

Introduction

1

The GRASI Unit (**GR**radient **And** **S**him Interface) is an interface device designed to drive several gradient amplifiers. Its main function is to lead the gradient pulse sequence signals coming from the Gradient Control Unit to the different amplifiers (X, Y, Z and B0 channels). The integrated power control function protects the gradient set connected to the amplifiers from over_voltage, over_current and the duty cycle is controlled to avoid any power excess on the loads.

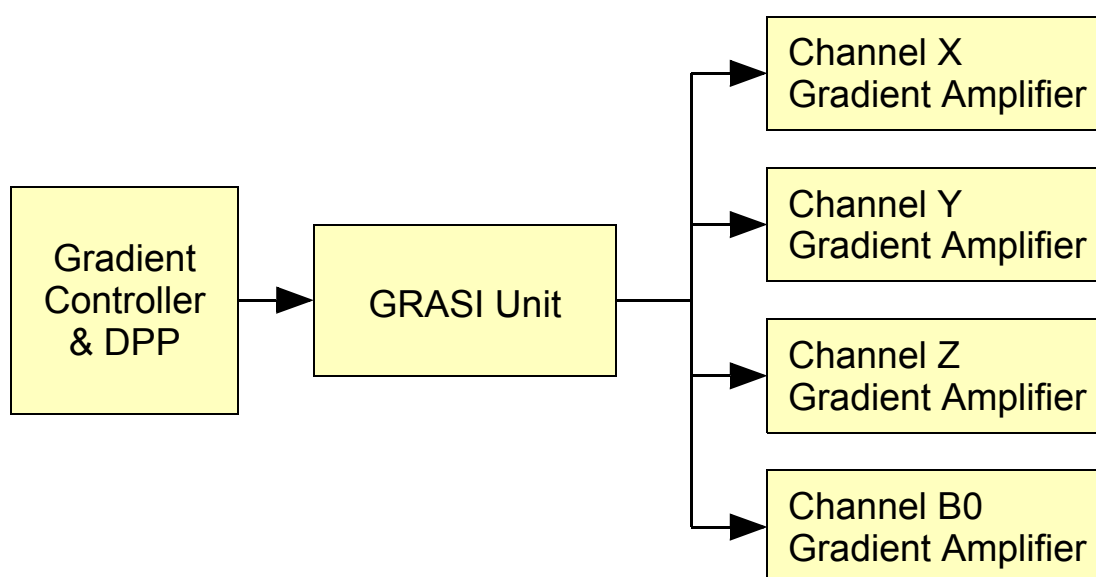

Figure 1.1. GRASI Unit diagram



Figure 1.2. GRASI Gradient and Shim Unit



The GRASI is in accordance with the standard IEC/61010-1:2001 safety Requirements for Electrical Equipments.

Instructions

2.1

The GRASI Unit contains live parts. Using the device with cover removed is forbidden.

Risk of electrical shocks! Be sure of voltage absence before every intervention on the device.

The different wirings must be done by an authorized and qualified technician. Use only the provided cables. Never disconnect any cable during the use of the device.

Sprinkling or pouring liquids on the device is forbidden. Use a wet or alcohol soaked rag to clean the EMB.

For corrective actions contact the BRUKER BIOSPIN representative in your country.

Labels

2.2

Labels are provided to alert operating and service personnel to conditions that may cause personal injury or damage to the equipment from misuse or abuse. Please read the labels and understand their meaning.

Identifying plate

2.2.1

The GRASI can be identified by an identifying plate at the front panel of the unit that has following information.

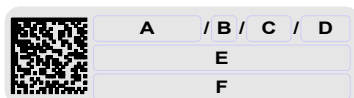

Figure 2.1. Identifying plate

- **(A) Part Number**
This field indicates the part number of the product.

- **(B) Variant**
This field indicates the variant number that identifies the production category of the product. The default variant is 00.
- **(C) ECL**
This field indicates the revision number that identifies the product configuration. The initial revision is 0.00.
- **(D) Serial Number**
This field indicates the serial number of the product.
- **(E) Type**
This field contains the designation of the product.
- **(F) Information**
This field contains additional information about the product.

Manufacturer's nameplate

2.2.2

The GRASI can be identified by a manufacturer's nameplate at the back panel of the unit that has following information:

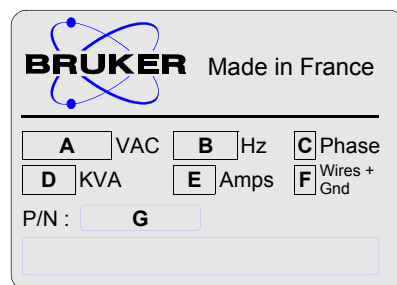

Figure 2.2. Manufacturer's nameplate

- **(A) Voltage**
This field indicates the input mains voltage of the product.
- **(B) Frequency**
This field indicates the input mains frequency of the product.
- **(C) Phases**
This field indicates the number of phases of the mains.
- **(D) Power**
This field indicates the absorbed power of the product.
- **(E) Current**
This field indicates the absorbed current of the product.
- **(F) Wires**
This field indicates number of wires with the ground in the mains cord.
- **(G) Part Number**
This field indicates the assembly number that identifies the part number of the product.

Table 2.1. Danger

**DANGER!**

Please disconnect line cord before opening or prevent potential hazards such as:

- Electric shock on power supply.
- Contact burn with heatsink.

Installation

3

The installation of the device must be done only by an authorized and qualified technician, in total accordance with the running standards. Every breakdown due to a non-respect of the following instructions will not be attributable to Bruker and will not be covered by the guarantee clauses.

Initial inspection

3.1

Mechanical check

3.1.1

If damage of the shipping cardboard is evident, request the carrier's agent to be present when the instrument is unpacked. Check the equipment for damage and inspect the panel surfaces for dents and scratches.

Claim for damage

3.1.2

If the unit is mechanically damaged or fails to meet specifications upon receipt, notify BRUKER or our representative immediately. Retain the shipping cardboard and packing material for the carriers inspection as well as for subsequent use in re-turning the unit if necessary.

Reshipment and repackaging requirements

3.1.3

Whenever possible, the original cardboard and packing material should be used for reshipment. If the original packing material is not available, wrap the instrument in heavy paper or plastic. Use a strong shipping container. If a cardboard is used, it should be at least 200 lbs. test material.

Use shock absorbing material around all sides of the instrument to provide a firm cushion and to prevent from movements inside the container wall on each side. Protect the front panel by means of cardboard spacers inserted between the front panel and the shipping cardboard. Make sure that the instrument cannot move in the container during shipping. Seal the cardboard box with a good grade of shipping tape and mark the container :

" FRAGILE ELECTRONIC INSTRUMENT. "

Environment requirements

3.1.4

This GRASI unit is build for inside use only on a maximum high level of 2000m above sea level (6600 feet).

No specific cooling or ventilation is required.

Be sure that the GRASI unit has enough area around so that the free air flow into and out of the GRASI unit is not obstructed.

It should, however, be in an environment which conforms, the 5°C - 45°C (41°F - 113°F) thermal specifications, a 80% maximum relative humidity of air and a contamination level of 2 (means a normal, only non conductive contamination, temporary conductivity due to condensation is possible).

Installation requirements

3.2

No special precautions are necessary. Mount the equipment in an area which is relatively free of vibration, and has sufficient room for cable connections.

The GRASI unit is a class II of installation category.

Bench operation

3.2.1

The unit can be placed onto a secure flat surface.

System check

3.3

Before applying power for the first time the following items should be checked:

- The AC input voltage 208-230VAC range must be compatible with.
- All the necessary cables are connected regarding the labels.

Initial turn on procedure

3.4

The following list describes how to turn on the GRASI unit and what should be seen as this occurs.

Before starting this procedure, make sure that you have properly followed instructions in the section "**System check**".

1. Connect the amplifier to the AC line and turn the circuit breaker to ON.
2. Observe the indicators on the front panel :
 - The ON/OFF switch lights red.
 - After a few seconds, the 3 front panel LEDs light up red and the initialisation process is started.
3. After approximatively one minute, the LEDs turn off. The GRASI unit is ready for use.
4. If the LEDs do not turn off, see the "**Troubleshooting**" on page 15.

Operation

4

General fonctions

4.1

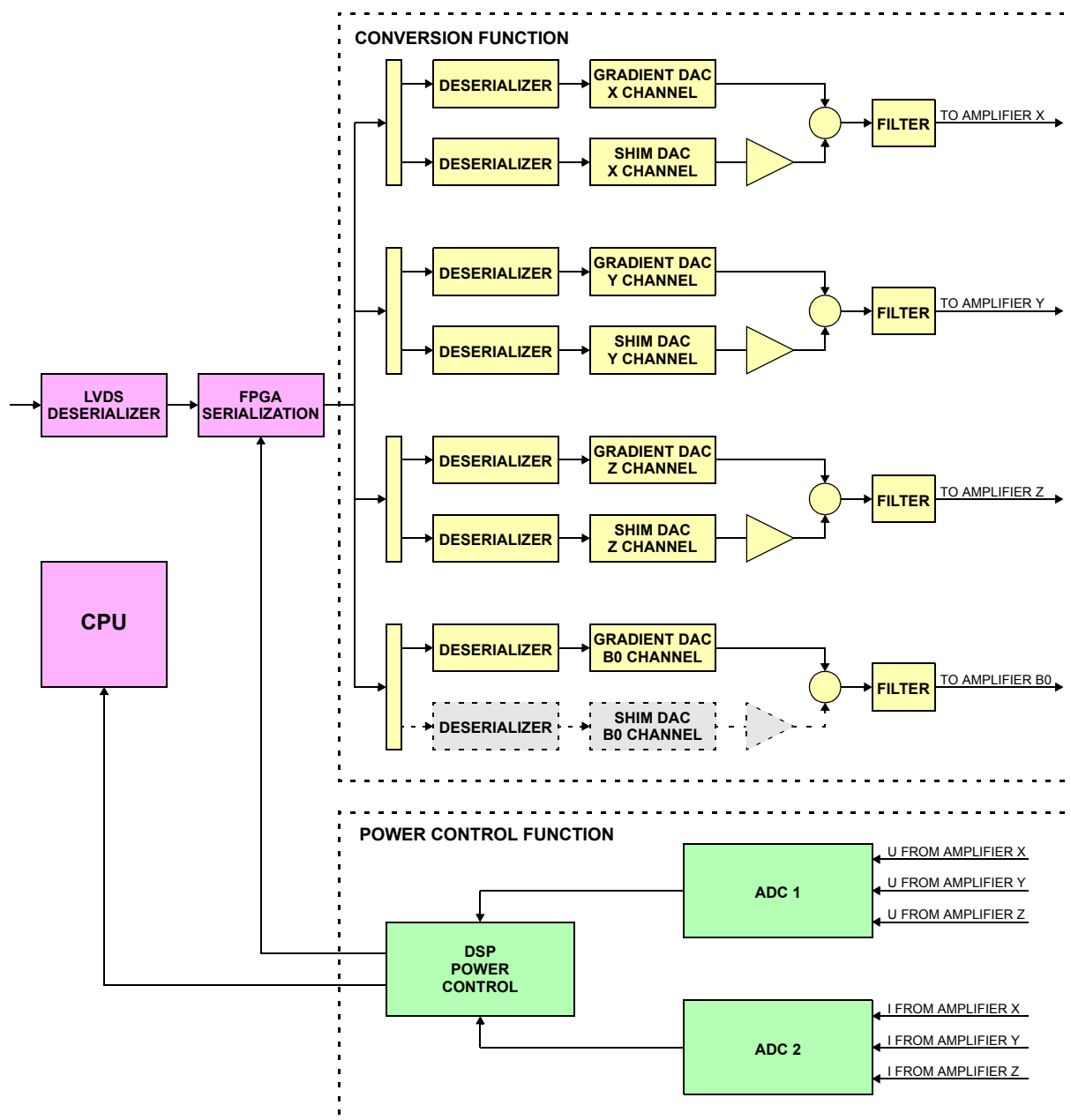

Figure 4.1. Functional block diagram

Amplifier selection

4.1.1

The first step before starting is to select the type of amplifier used with the GRASI unit. This selection is performed using a dedicated Web page. This action should be done only by Bruker trained personnel. Choosing a wrong amplifier type can lead to irreversible damage of the entire spectrometer. The selection is done once at the first switch on. Once this selection is made, there should be no reason to select another type of amplifier. If for any reason a change of amplifier type is made, the type of the previously selected amplifier will be saved for safety reasons.

Coil code selection

4.1.2

The Coil Code selection occurs automatically when the SUB-D 37 connector is inserted. The code is detected and in accordance with the selected amplifier, the different limit values for the power control are set. The control function supported by the DSP uses these values to check if a limit is overridden.

Powering up

4.1.3

The GRASI Unit is switched on helps the "ON/OFF" button located on the front panel.

Initialisation process

4.1.4

The initialisation process needs about one minute to be completed. During the initialisation process, the output channels are calibrated and the offset corrected.



Important : After switching on the GRASI Unit, the switch light lights red. A few seconds after switching on, the three front panel LEDs light up red and remain lightened for about one minute. This is the external sign for the operator to announce initialisation process. Once the three front panel LEDs switched off, the GRASI Unit is ready for operation. Please note that during initialisation process, no commands should be sent to the GRASI Unit.

Calibration

4.1.5

Before the device can be used for imaging application, all calibration steps must be done according to the ParaVision/TopSpin tune-up procedure.



Warning : *Danger hardware damage. Missing or wrong calibration settings can lead to destruction of gradient hardware and insufficient image quality.*

Error messages**4.2**

When an error occurs, this is announced by the three front panel LEDs.

The error description is as follows :

Table 4.1. Troubleshooting

Description of the message	Nature of the error	Troubleshooting
Over_voltage LED lights red	A voltage limit has been overridden	Check the gradient set and the amplifier output
Over_current LED lights red	A current limit has been overridden	Check the gradient set and the amplifier output
Duty Cycle LED lights red	The duty cycle limit has been overridden	Check the pulse program
The three LEDs light red together in blinking mode	No limit values available, the DSP control could not be started	Check if an amplifier is selected, check if the Coil Code is selected
The three LEDs are blinking in turn	An internal error occurred	HW-Reset the GRASI Unit

Technical description

5

General description

5.1

The GRASI is a 19" unit with following dimensions :

- Height : 2U
- Width : 19"
- Depth : 460mm
- Weight : 8kg

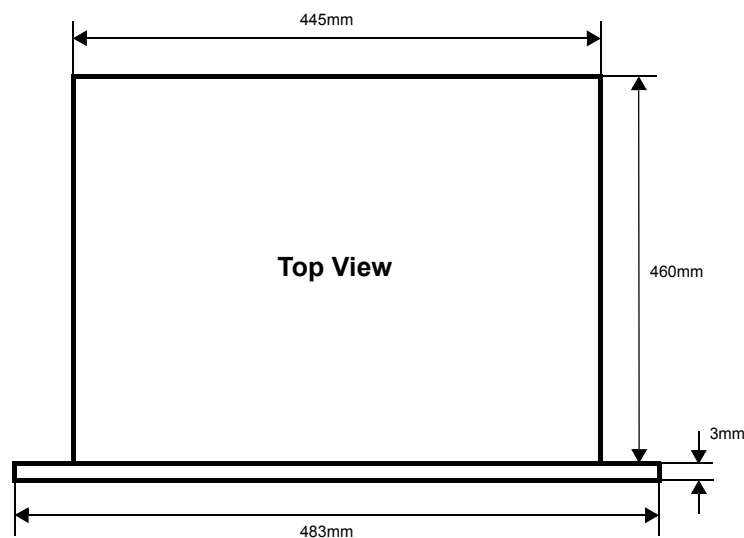

Figure 5.1. Housing dimensions

Power requirements

5.2

The GRASI Unit is powered by the mains input.

Main characteristics

- AC input voltage range : 208-230VAC
- AC inrush current : 40A at 230VAC
- Power consumption : 220VAC 300mA
- Fuses : 2A T 250VAC

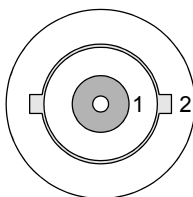

Figure 5.2. Figure 7 : BNC female connector

Table 5.1. BNC female of Monitor X definition

Pins	Descriptions
1	MONITOR_X
2	MONITOR_X_GND

Table 5.2. BNC female of Monitor Y definition

Pins	Descriptions
1	MONITOR_Y
2	MONITOR_Y_GND

Table 5.3. BNC female of Monitor Z definition

Pins	Descriptions
1	MONITOR_Z
2	MONITOR_Z_GND

Table 5.4. BNC female of Monitor B0 definition

Pins	Descriptions
1	MONITOR_B0
2	MONITOR_B0_GND

Front panel indicators

5.4

The front panel is equipped with three red LED's to indicate different errors.

- Overvoltage
- Overcurrent
- Duty Cycle



Figure 5.3. Red led indicator

Front panel buttons

5.5

This unit is equipped with a "RESET" button to reset errors.



Figure 5.4. Error reset button

Rear panel connectors

5.6

Gradient Coil Code connector from Gradient set

5.6.1

Coil Code Interface Connector from Coil to GRASI.

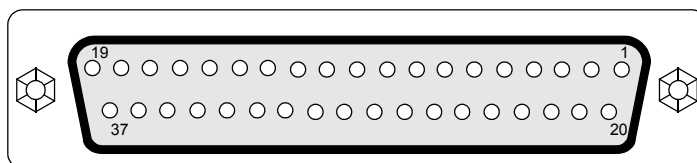

Figure 5.5. Sub-D 37 pin female connector

Technical description

Table 5.5. Sub-D 37 pin female definition

Pins	Descriptions	To use	Pins	Descriptions	To use
1	SCHALT_GND	Used	20	TC_4	Unused
2	SCHALT_A0	Used	21	TC_5	Unused
3	SCHALT_A1	Used	22	TC_6	Unused
4	SCHALT_A2	Used	23	PT100_GND	Unused
5	SHIM_P5V (Interlock)	Unused	24	TC_GND	Unused
6	SHIM_GND (Interlock)	Unused	25	SCREEN	Unused
7	GRAD_P5V (Interlock)	Unused	26	NC	Unused
8	GRAD_GND (Interlock)	Unused	27	NC	Unused
9	PT100_1	Unused	28	NC	Unused
10	PT100_2	Unused	29	NC	Unused
11	PT100_3	Unused	30	NC	Unused
12	PT100_4	Unused	31	NC	Unused
13	PT100_5	Unused	32	NC	Unused
14	PT100_6	Unused	33	NC	Unused
15	SCHALT_A3 (reserve)	Used	34	NC	Unused
16	SCHALT_A4 (reserve)	Used	35	NC	Unused
17	TC_1	Unused	36	NC	Unused
18	TC_2	Unused	37	NC	Unused
19	TC_3	Unused			

Status and Command connector from GPSCU

5.6.2

Status and Command connectors from GPSCU to GRASI on each channel.

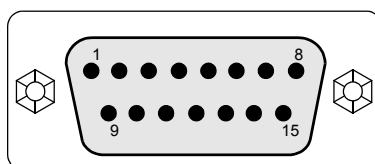

Figure 5.6. Sub-D 15 pin male connector

Table 5.6. Sub-D 15 pin male definition

Pins	Descriptions	Pins	Descriptions
1	SHIELD (2, 9)	9	IN+
2	IN-	10	NC
3	NC	11	RESET
4	VOLT MON	12	SHIELD (4, 11)
5	EN+	13	CURR MON
6	EN-	14	NORMAL
7	SHIELD (13, 14)	15	CLK
8	SHIELD (5, 6, 15)		

Status and Command connector to amplifier

5.6.3

Status and Command connector from GRASI to Amplifier on each channel.

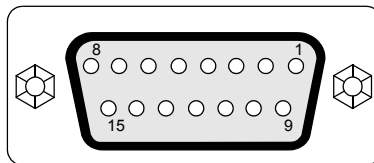

Figure 5.7. Sub-D 15 pin female connector

Table 5.7. Sub-D 15 pin female definition

Pins	Descriptions	Pins	Descriptions
1	SHIELD (2, 9)	9	IN+
2	IN-	10	NC
3	NC	11	RESET
4	VOLT MON	12	SHIELD (4, 11)
5	EN+	13	CURR MON
6	EN-	14	NORMAL
7	SHIELD (13, 14)	15	CLK
8	SHIELD (5, 6, 15)		

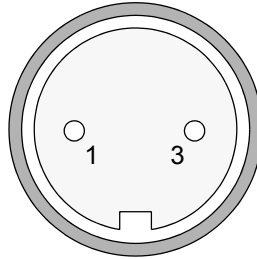

Figure 5.8. Binder 2 pin female connector

Table 5.8. Binder 2 pin female definition

Pins	Descriptions
1	INTERLOCK
2	INTERLOCK_GND

Coil Code Binder from GRASI to GPSCU.

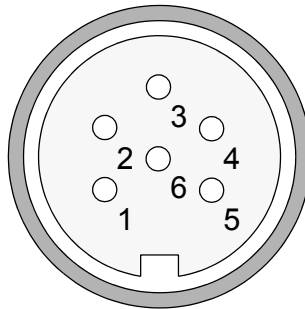

Figure 5.9. Binder 6 pin female connector

Table 5.9. Binder 6 pin female definition

Pins	Descriptions	Pins	Descriptions
1	GND	4	A2
2	A0	5	A3
3	A1	6	A4

B0 Output Twinaxe connector

5.6.6

B0 Output +/-10V Twinaxe.

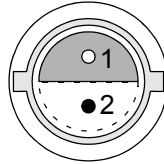

Figure 5.10. Twinaxe connector

Table 5.10. Twinaxe definition

Pins	Descriptions
1	B0_OUT+
2	B0_OUT-
3	SHIELD

Interface Connector Ethernet 10/100

5.6.7

The RJ45 connector for the Ethernet 10/100 Mbps link is mounted directly on the CPU-A Board.

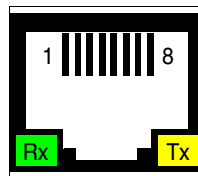

Figure 5.11. RJ45 8 pin connector

Table 5.11. RJ45 8 pin definition

Pins	Descriptions	Pins	Descriptions
1	Transmit + (Tx+)	5	N/A
2	Transmit - (Tx-)	6	Receive - (Rx-)
3	Receive + (Rx+)	7	N/A
4	N/A	8	N/A



Figure 5.12. Rear panel view

Servicing the GRASI

6

Diagnosis and servicing access to the GRASI unit relies on HTTP, allowing service access with any web browser.

Accessing the GRASI unit

6.1

The GRASI Gradient and Shim Interface Unit is accessible via the CPU-A board with its IP address.

The IP address is given during "cf" by using TOPSPIN 2.xx software under PARAVISION 5 on the workstation.

In case of problems :

- Check the RJ45 cabling between GRASI, Ethernet switch and workstation.
- Check the Ethernet switch power.
- Check if the green LED on the GRASI RJ45 connector lights up.

To access the GRASI unit, type "ha" in TOPSPIN 2.xx and choose the GRASI that should be accessed or start your favourite web browser and type the given IP address as URL.

Some of these pages are only status pages to inform the operator, some other pages allow to modify several parameters of the GRASI unit.

You should get the following start screen.

This page shows the main information of the device.

On the left frame, the operator can choose a submenu to get the remaining information concerning the device.

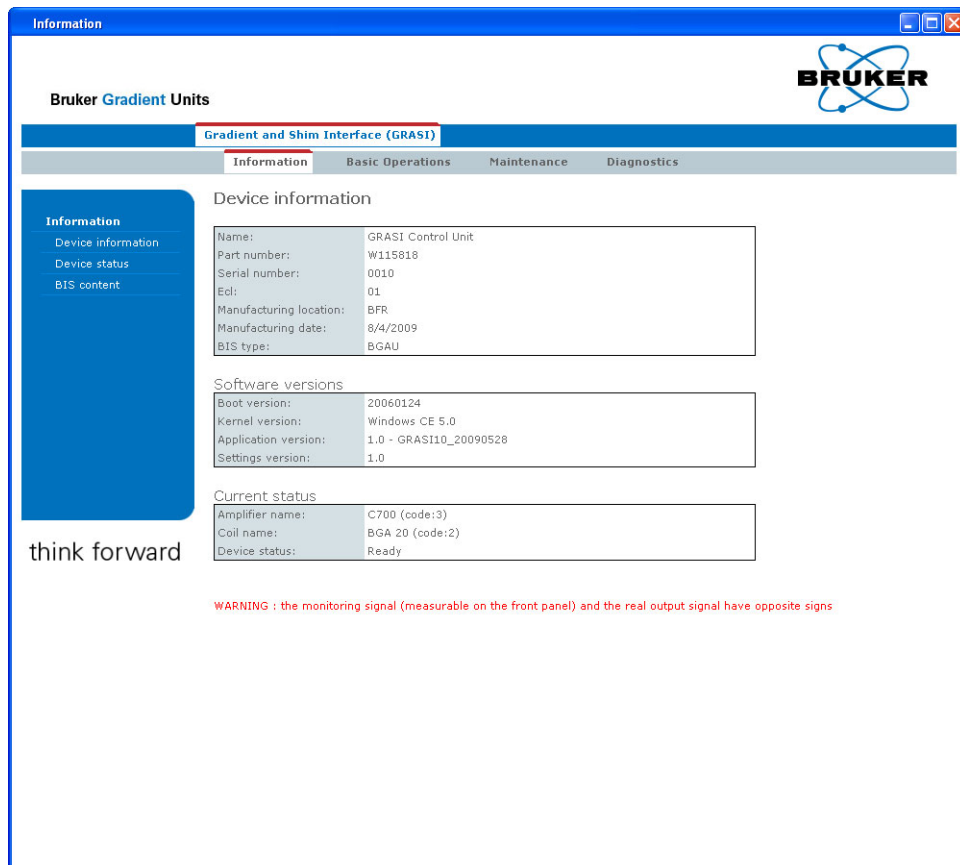

Figure 6.1. Device Information

Select the tab "Information", then the item "Device status".

This page shows the device status.

When a fault is detected, the corresponding item is in red color.

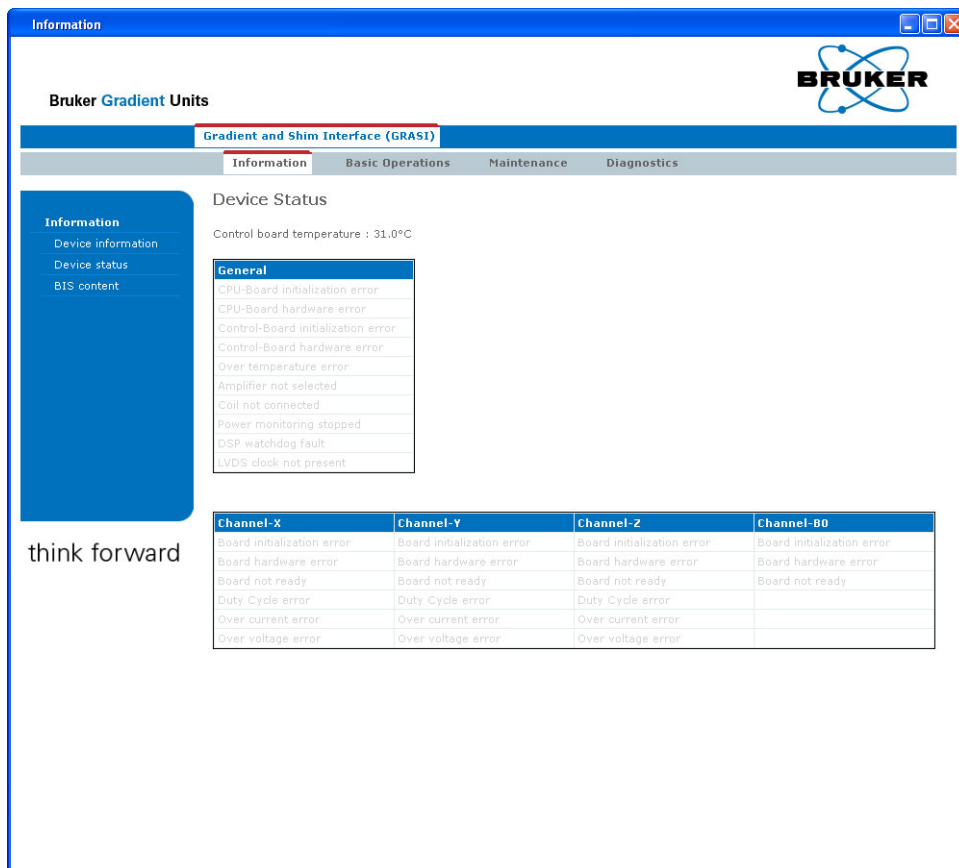

Figure 6.2. Device Status

This page shows the BIS content of the different GRASI channels. It also shows the BIS content of the CPU board and the Controller board.

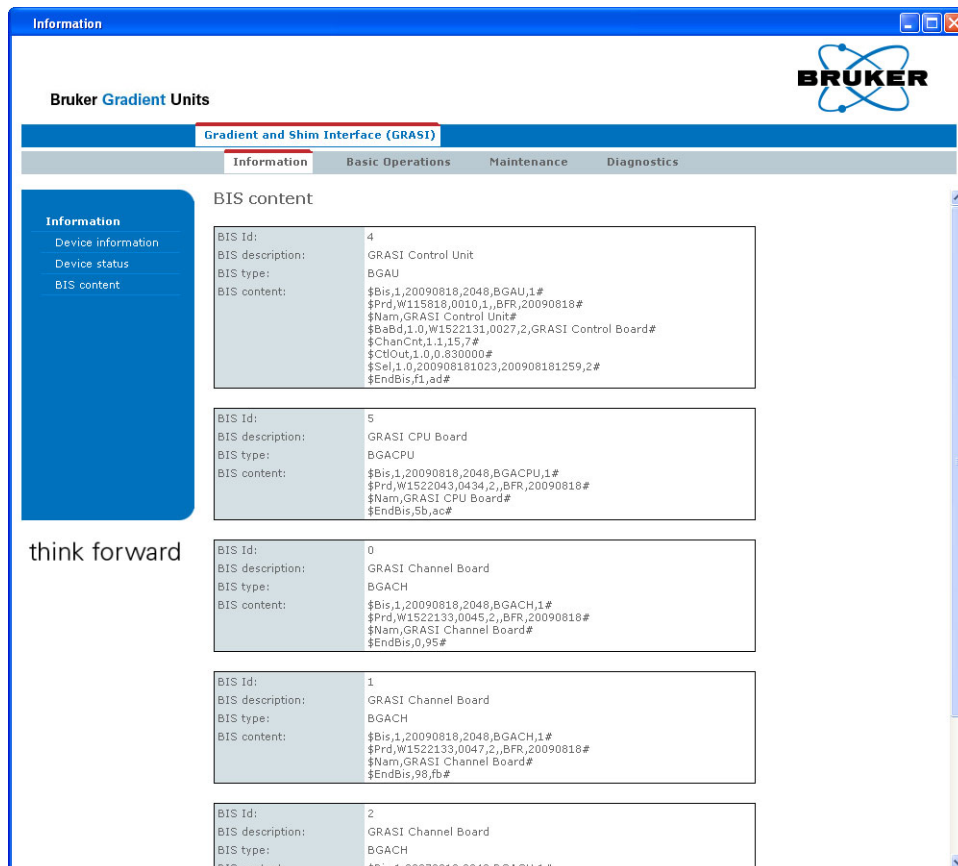

Figure 6.3. BIS Content

Sub Toolbar Basic Operations

6.3

Reset Error

6.3.1

Select the tab "Basic Operations".

If necessary, click the item "Reset error" on the left menu.

This has the same effect as the "Reset error" button on the GRASI front panel.

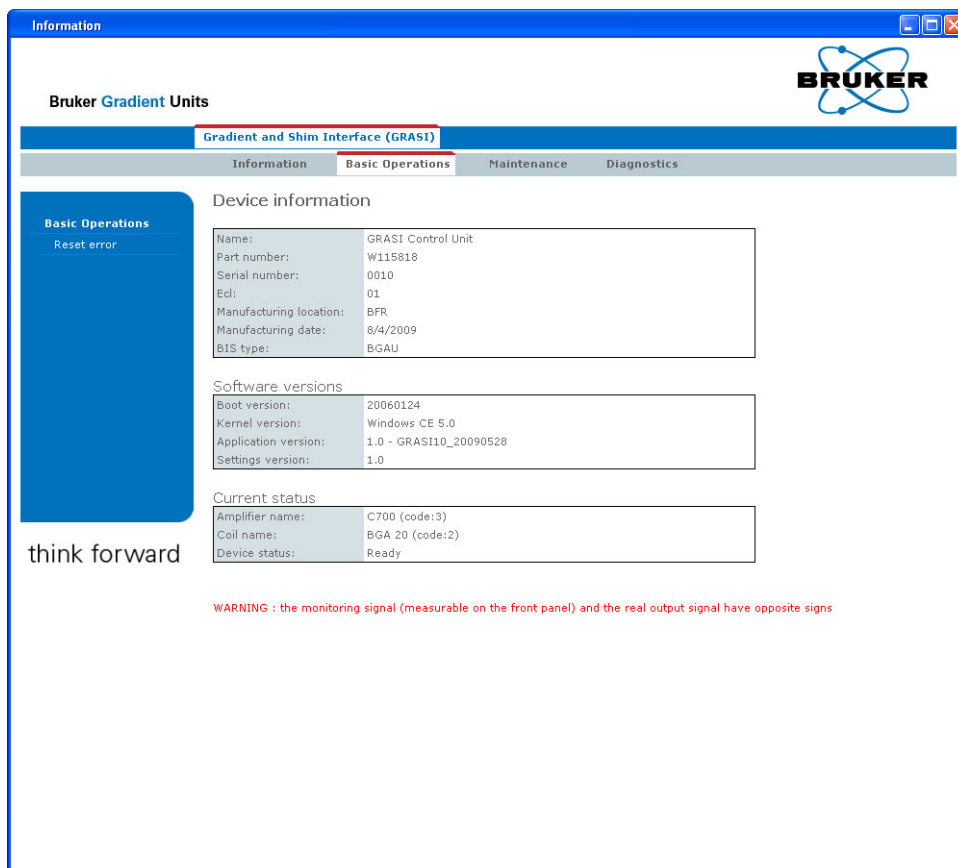

Figure 6.4. Reset Error

When necessary, some settings may be updated or upgraded via BRUKER data files. In this case, select the tab "Maintenance", then the item "Settings update" in the left menu.

Select the settings file with the browser, then click the "**Update**" button to start the update process.

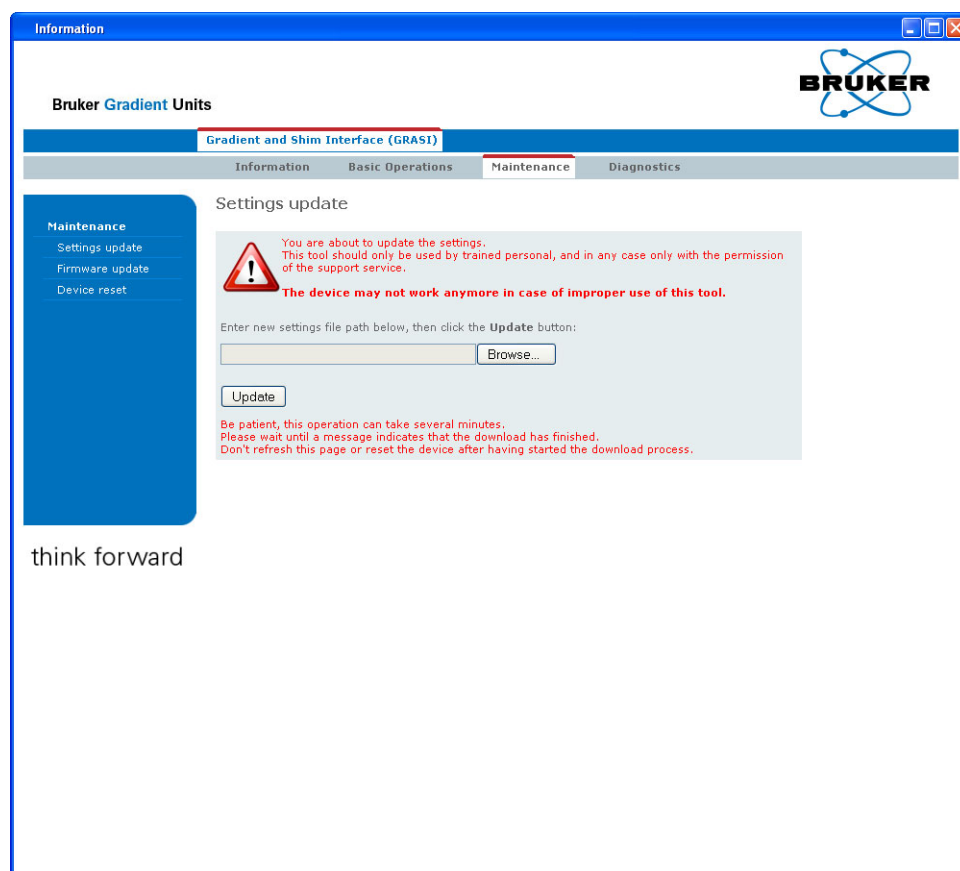

Figure 6.5. Settings Update

Select the tab "Maintenance", then the item "Firmware update" in the left menu.

This page allows the operator to update the firmware of the internal CPU of the device.

The operator will have to choose the correct file using the "**Browse...**" button and then click the "**Update**" button to start the update process. This process may request several minutes. Please do not quit before the window changes and informs that the update was successful. The two windows are the following:

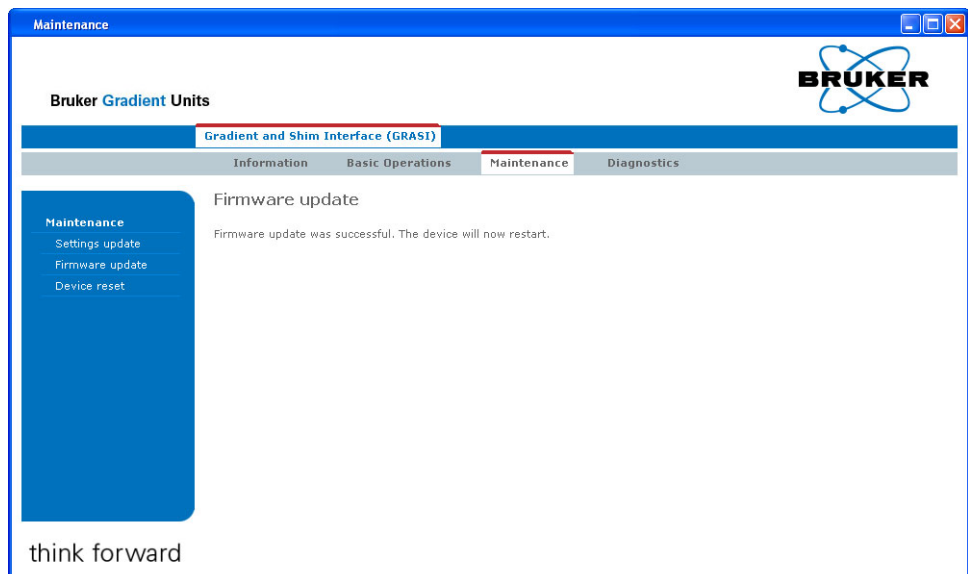
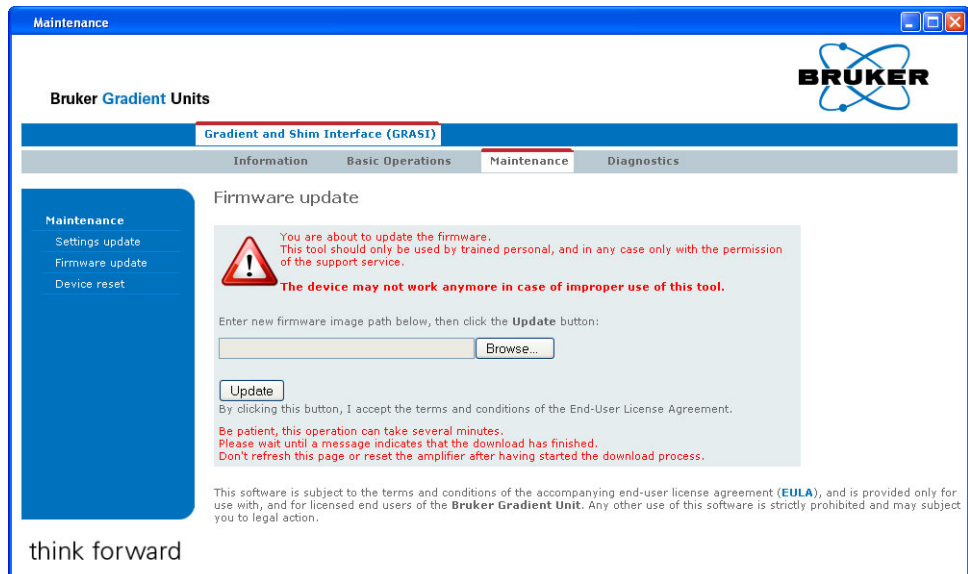

Figure 6.6. Firmware Update

Select the tab "Maintenance", then the item "Device reset" in the left menu.

On this page, the operator is allowed to reset the GRASI unit.

In order to avoid an undesired reset, the operator will have to confirm by clicking the "**Perform Software Reset**" button.

Resetting the device sets it into the same state as after the first turn on.

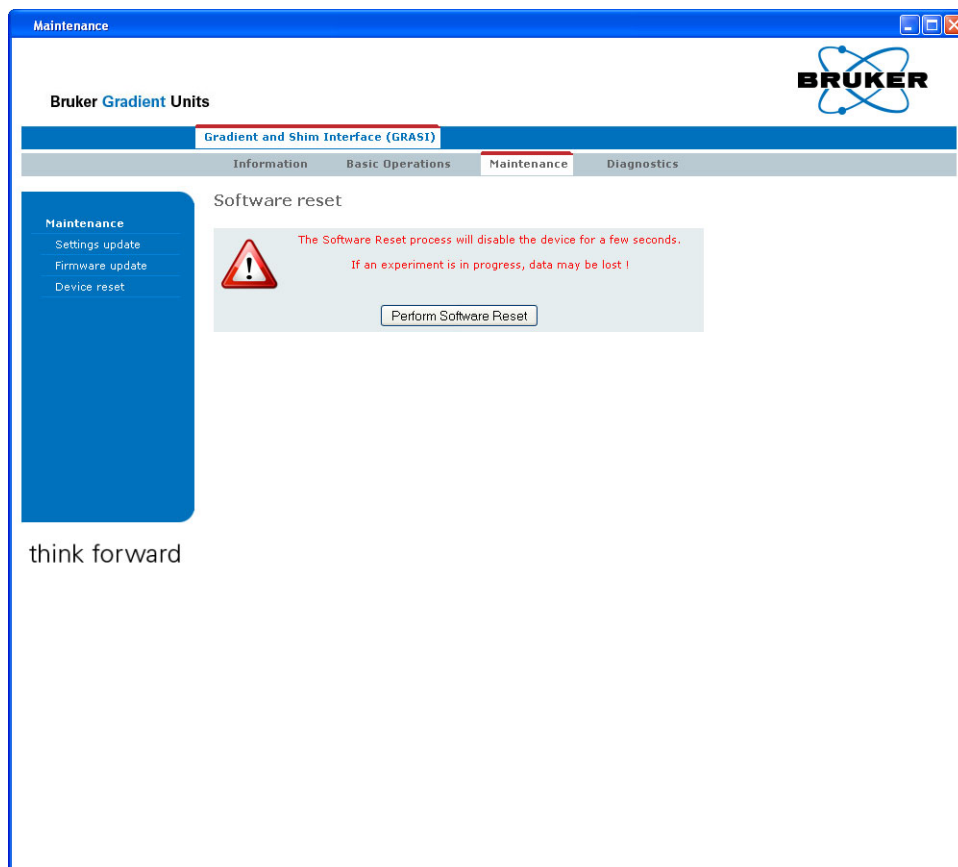

Figure 6.7. Device Reset

Sub Toolbar Diagnostics

6.5

Event Log

6.5.1

Select the tab "Diagnostics", then the item "Event log" in the left menu.

On this page, the operator can verify which actions have been performed and which events happened since the unit has been switched on.

Event log

Line	Severity	Message
00001	INFO	[MAIN] Firmware version : 1.0 - GRASI10_20090605_NR
00002	INFO	[UPNP] Message Queue created
00003	INFO	[GRASI] initializing peripheral bus handle...
00004	INFO	[GRASI] loading FPGA...
00005	INFO	[GRASI] initializing I2C bus handle...
00006	INFO	[GRASI] initializing CPU board...
00007	INFO	[GRASI] initializing CONTROL board...
00008	INFO	[GRASI] initializing CHANNEL X board...
00009	INFO	[GRASI] initializing CHANNEL Y board...
00010	INFO	[GRASI] initializing CHANNEL Z board...
00011	INFO	[GRASI] initializing CHANNEL B0 board...
00012	INFO	[SETTINGS] version : 1.0
00013	INFO	[GRASI] amplifier[2:C265] limits selected
00014	INFO	[GRASI] coil[4:BG 6] limits selected
00015	INFO	[GRASI] scale factor [0.830] used
00016	INFO	[GRASI] Current limit : 100.0 A => 5.060 V
00017	INFO	[GRASI] Voltage limit : 150.0 V => 3.938 V
00018	INFO	[GRASI] Power limit on X : 70.0 W
00019	INFO	[GRASI] Power limit on Y : 100.0 W
00020	INFO	[GRASI] Power limit on Z : 90.0 W
00021	INFO	[CHANNEL_X] amplifier input level set to 5V
00022	INFO	[CHANNEL_Y] amplifier input level set to 5V
00023	INFO	[CHANNEL_Z] amplifier input level set to 5V
00024	INFO	[CHANNEL_B0] amplifier input level set to 5V
00025	INFO	[MAIN] starting WebServices server...
00026	INFO	[MAIN] starting main loop...

Figure 6.8. Event Log

Specification

7

General specifications

7.1

Table 7.1. GRASI Unit Specifications

Constant Internal Protection	Overcurrent , Overvoltage and Duty Cycle Overriding detection on the 4 channels
Front Panel Indicators	ON / OFF switch light Overvoltage, Overcurrent and Duty Cycle error LEDs
Front Panel Connectors	4 x BNC, Input Monitor for channel X, Y, Z and B0
Front Panel Controls	AC Line ON / OFF, Error Reset button
Rear Panel Indicators	Ethernet status LEDs
Rear Panel Connectors	AC Line Connector 1 x SUB-D 37 Coil Code Connector from Gradient Set 1 x 2 pin BINDER Interlock Connector 1 x 6 pin BINDER Coil Code Connector to GPSCU 1 x TWINAXE B0 Output Connector 1 x LVDS Connector 1 x Ethernet Connector 1 x USB B Connector 2 x USB A Connector 1 x SUB-D 15 from GRASI channel B0 to Amplifier B0 Connector 1 x SUB-D 15 from GRASI channel X to Amplifier X Connector 1 x SUB-D 15 from GRASI channel Y to Amplifier Y Connector 1 x SUB-D 15 from GRASI channel Z to Amplifier Z Connector 1 x SUB-D 15 from GPSCU to GRASI Channel B0 Connector 1 x SUB-D 15 from GPSCU to GRASI Channel X Connector 1 x SUB-D 15 from GPSCU to GRASI Channel Y Connector 1 x SUB-D 15 from GPSCU to GRASI Channel Z Connector
Rear Panel Interface	LVDS 48 bit from GCON or DPP Ethernet 10/100 Base T Tx
Cooling System	Natural Convection
Size	19" rack cabinet x 2U height x 460mm depth
Weight	8kg
Power requirements	100 - 240VAC \pm 10%, single phase 50-60Hz Bruker part number W1522072 Consumption max. 69VA (0,300A @ 230VAC)

Specification

Table 7.2. GRASI unit Inputs / Outputs specifications

Ouputs	± 10 VDC on set value for channel B0 ± 10 VDC on set value for channel X ± 10 VDC on set value for channel Y ± 10 VDC on set value for channel Z
Inputs	± 10 VDC for I monitoring on channel X ± 10 VDC for U monitoring on channel X ± 10 VDC for I monitoring on channel Y ± 10 VDC for U monitoring on channel Y ± 10 VDC for I monitoring on channel Z ± 10 VDC for U monitoring on channel Z
Open or Closed Contacts	Interlock to GPSCU (on 2 pin BINDER Interlock Connector) A0 to A6 for Coil Code (on SUB-D 37 Coil Code Connector from Gradient Set and 6 pin BINDER Coil Code Connector to GPSCU)

Figures

1 Introduction	5
Figure 1.1. GRASI Unit diagram	5
Figure 1.2. GRASI Gradient and Shim Unit	5
2 Safety	7
Figure 2.1. Identifying plate	7
Figure 2.2. Manufacturer's nameplate	8
3 Installation	11
4 Operation	13
Figure 4.1. Functional block diagram	13
5 Technical description	17
Figure 5.1. Housing dimensions	17
Figure 5.2. Figure 7 : BNC female connector	18
Figure 5.3. Red led indicator	19
Figure 5.4. Error reset button	19
Figure 5.5. Sub-D 37 pin female connector	19
Figure 5.6. Sub-D 15 pin male connector	20
Figure 5.7. Sub-D 15 pin female connector	21
Figure 5.8. Binder 2 pin female connector	22
Figure 5.9. Binder 6 pin female connector	22
Figure 5.10. Twinaxe connector	23
Figure 5.11. RJ45 8 pin connector	23
Figure 5.12. Rear panel view	24
6 Servicing the GRASI	25
Figure 6.1. Device Information	26
Figure 6.2. Device Status	27
Figure 6.3. BIS Content	28
Figure 6.4. Reset Error	29
Figure 6.5. Settings Update	30
Figure 6.6. Firmware Update	31
Figure 6.7. Device Reset	32
Figure 6.8. Event Log	33
7 Specification	35

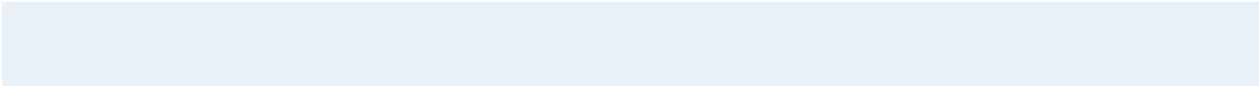

Tables

1 Introduction	5
2 Safety	7
Table 2.1. Danger	9
3 Installation	11
4 Operation	13
Table 4.1. Troubleshooting	15
5 Technical description	17
Table 5.1. BNC female of Monitor X definition	18
Table 5.2. BNC female of Monitor Y definition	18
Table 5.3. BNC female of Monitor Z definition	18
Table 5.4. BNC female of Monitor B0 definition	18
Table 5.5. Sub-D 37 pin female definition	20
Table 5.6. Sub-D 15 pin male definition	21
Table 5.7. Sub-D 15 pin female definition	21
Table 5.8. Binder 2 pin female definition	22
Table 5.9. Binder 6 pin female definition	22
Table 5.10. Twinaxe definition	23
Table 5.11. RJ45 8 pin definition	23
6 Servicing the GRASI	25
7 Specification	35
Table 7.1. GRASI Unit Specifications	35
Table 7.2. GRASI unit Inputs / Outputs specifications	36

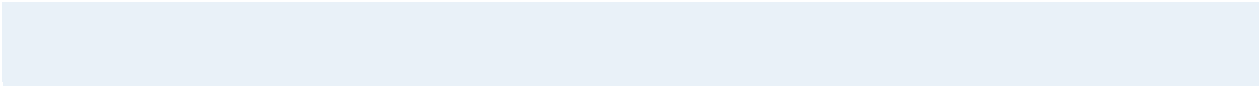



End of Document

Bruker BioSpin, your solution partner

Bruker BioSpin provides a world class, market-leading range of analysis solutions for your life and materials science needs.

● **Bruker BioSpin Group**

info@bruker-biospin.com
www.bruker-biospin.com

