

Bruker BioSpin

BLA2H500 E ●

Amplifier 400-500MHz
Operating & Service Manual

Version 001

think forward

NMR Spectroscopy

The information in this manual may be altered without notice.

BRUKER BIOSPIN accepts no responsibility for actions taken as a result of use of this manual. BRUKER BIOSPIN accepts no liability for any mistakes contained in the manual, leading to coincidental damage, whether during installation or operation of the instrument. Unauthorised reproduction of manual contents, without written permission from the publishers, or translation into an other language, either the entire manual or a part of it, is forbidden.

This manual describes the units as they are at the date of printing. On request, the manufacturer shall supply circuit diagrams, lists of components, descriptions, calibrating instructions and any other information for use by qualified personnel of the user, in charge of repairing the parts of the unit which have been stated by the manufacturer to be "repairable". Such supply shall in no event constitute permission to modify or repair the units or approval of the same.

All rights reserved for the units, circuits, processes and appellations mentioned herein.

This unit is not designed for any type of use which is not specifically described in this manual. Such use may be hazardous.

This manual was written by

[Jacky Schaeffer](#)

This manual was edited and desktop published by

[Dominique Wurtz](#)

© October 14, 2009: Bruker BioSpin

Wissembourg, France

P/N: Z31830

DWG-Nr: Z4D10534

For further technical assistance on the BLA2H500 E unit, please do not hesitate to contact your nearest BRUKER dealer or contact us directly at:

BRUKER BioSpin
34 rue de l'Industrie
F-67166 Wissembourg Cedex
France

Phone: + 33 388 066 000

Fax: + 33 388 736 820

Email: support-rmn@bruker.fr

Internet: www.bruker.com

Contents

	Contents	3
1	General Information	5
1.1	Introduction	5
2	Safety	7
2.1	Identification Labels	7
	Identifying Plate	7
	Manufacturer's Name Plate	8
2.2	Safety Labels and Symbols	9
	Warning Signs	9
	Danger	9
	Instruction	9
3	Installation	11
3.1	Initial Inspection	11
	Mechanical Check	11
	Claim for Damage	11
	Reshipment and Repackaging Requirements	11
	Environment Requirements	12
3.2	Installation Requirements	12
	Bench Operation	12
3.3	Power Requirements	12
3.4	System Check	12
3.5	Initial Turn on Procedure	13
4	Operation	15
4.1	Front Panel Description	15
	Indicators	15
	Coaxial Connectors	16
	Ethernet 10/100 Interface Connector	16
	Device Front View	17
4.2	Rear Panel Description	18
	Device Rear View	18
5	Technical Description	19
5.1	System Overview	19
5.2	Theory of Operation	21
	RF Path	21
	RF Power Amplifiers	21
	RF Couplers	21
	RF Isolators	21

	BLA Control Board	22
	BLA Extension Board	24
	Status Led Board	24
	BIS Board	24
6	<i>Servicing the BLA</i>	25
6.1	Accessing the BLA Amplifier	25
6.2	Sub Toolbar Information	26
	Device Information (default)	26
	Amplifier Status	27
6.3	Sub Toolbar Advanced Operations	28
	Device Information (advanced)	28
	Amplifier Limitations	29
	Change Limits	30
	Routing Information and Setting	31
6.4	Sub Toolbar Maintenance	32
	Device Information (maintenance)	32
	Self-Test & Software Reset	33
	Firmware Update	35
	BIS Content	36
7	<i>Specifications</i>	37
7.1	Common Characteristics	37
7.2	General Specifications	38
	Channel H1 and H2 500W Output	38
8	<i>Service Information and Maintenance</i>	39
8.1	Preventive Maintenance of the RF Module on BLA-Type Amplifiers ..	39
	Operation	39
	<i>Figures</i>	41
	<i>Tables</i>	43

General Information

1

Introduction

1.1

The BLA2H500 E Amplifier 400-500MHz is a broadband linear pulse power amplifier specifically designed for Magnetic Resonance Imaging (MRI) application for 9,4 to 11,7 Teslas Systems. It is commercialized under the BRUKER BIOSPIN part number W1345508.

It is operated in AB linear class and provides twice 500W and more peak RF power over the frequency range 400-500MHz on the H1 OUT and H2 OUT channel output.

The amplifier is equipped with **N-Channel RF LDMOSFETs** transistors of the latest generation. The unit can provide full power for any combination of pulse width and duty cycle up to 60ms and 6%.

Its built-in protection circuitry will allow lower power pulses for longer pulse widths and duty-cycles, maintaining a 30W average power on the both channel output.

The electronic protection circuitry has been designed to protect against:

- Excessive power output level (overdrive)
- Excessive pulse repetition rate (over duty-cycle protection)
- Excessive pulse duration (over pulse-width)
- More than 50% reflected RF power (mismatch when $VSWR \geq 6$)
- Thermal protection (overheat)

The amplifier is powered by an internal switched power supply assembly that provides the +32VDC for the power amplifiers, in addition to all low level voltages for the system.

The supply is self protected for overcurrent and overvoltage.

The entire unit is housed in a 19", 3U, 520mm rack cabinet.

General Information



The BLA2H500 E Amplifier 400-500MHz is in accordance with the standard 61010-1 and with the UL 61010-1 / CSA C22.2 No.61010-1-04 Safety Requirements for Electrical Equipments.

Identification Labels

2.1

Labels are provided to alert operating and service personnel to conditions that may cause personal injury or damage to the equipment from misuse or abuse. Please read the labels and understand their meaning.

Identifying Plate

2.1.1

The BLA2H500 E Amplifier 400-500MHz can be identified by an identifying plate at the front panel of the unit that contains the following information :

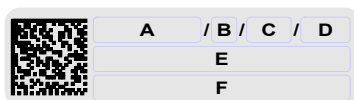

Figure 2.1. Identifying Plate

- **(A) Part Number**
This field indicates the part number of the product.
- **(B) Variant**
This field indicates the variant number that identifies the production category of the product. The default variant is 00.
- **(C) ECL**
This field indicates the revision number that identifies the product configuration. The initial revision is 0.00.
- **(D) Serial Number**
This field indicates the serial number of the product.
- **(E) Type**
This field contains the designation of the product.
- **(F) Information**
This field contains additional information about the product.

The BLA2H500 E Amplifier 400-500MHz can be identified by a manufacturer's name plate at the back panel of the unit that contains the following information :

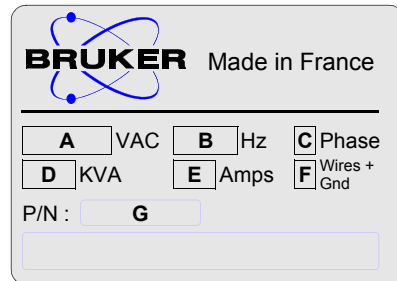

Figure 2.2. Manufacturer's Name Plate

- **(A) Voltage**
This field indicates the input mains voltage of the product.
- **(B) Frequency**
This field indicates the input mains frequency of the product.
- **(C) Phases**
This field indicates the number of phases of the mains.
- **(D) Power**
This field indicates the absorbed power of the product.
- **(E) Current**
This field indicates the absorbed current of the product.
- **(F) Wires**
This field indicates number of wires with the ground in the mains cord.
- **(G) Part Number**
This field indicates the assembly number that identifies the part number of the product.

Danger



DANGER! Risk of electrical shocks

Throughout this manual, this symbol indicates the possibility of severe personal injury, loss of life or equipment damage if the instructions are not followed.

On the equipment, the symbol also implies a danger and alerts the user.

Instruction

Operating personal should not remove RF output cable without turn off the power supply because the RF output can cause serious burns before the "Mismatch" protection is active.

Please disconnect the mains supply before opening to prevent potential hazard such as :

- Electrical shock from power supply
- Contact burns from the RF module and heatsink
- Finger scratch due to the fan assembly on the RF module.

Installation

3

The installation of the device must be done only by an authorized and qualified technician, in total accordance with the running standards.

BRUKER BIOSPIN assumes no liability for the customer's failure to comply with these requirements and is therefore not responsible or liable for any injury or damage that occurs as a consequence of non-approved installation.

Initial Inspection

3.1

Mechanical Check

3.1.1

If damage of the shipping cardboard is evident, request the carrier's agent to be present when the instrument is unpacked. Check the equipment for damage and inspect the cabinet and panel surfaces for dents and scratches.

Claim for Damage

3.1.2

If the unit is mechanically damaged or fails to meet specifications upon receipt, notify BRUKER or our representative immediately. Retain the shipping cardboard and packing material for the carriers inspection as well as for subsequent use in returning the unit if necessary.

Reshipment and Repackaging Requirements

3.1.3

Whenever possible, the original cardboard and packing material should be used for reshipment. If the original packing material is not available, wrap the instrument in heavy paper or plastic. Use a strong shipping container. If cardboard is used, it should be at least 200 lbs. test material.

Use shock absorbing material around all sides of the instrument to provide a firm cushion and to prevent movement from inside the container wall on each side. Protect the front panel by means of cardboard spacers inserted between the front panel and the shipping cardboard. Make sure that the instrument cannot move in the container during shipping. Seal the cardboard box with a good grade of shipping tape and mark the container :

"FRAGILE ELECTRONIC INSTRUMENT"

Environment Requirements

3.1.4

This amplifier is built for inside use only on a maximum elevation of 2000m above sea level (6600 feet).

No specific cooling or ventilation is required.

Be sure that the amplifier has enough area around it so that the free air flow into and out of the amplifier is not obstructed.

It should, however, be in an environment which conforms to the 5°C - 45°C (41°F - 113°F) thermal specifications, a 80% maximum relative humidity of air and a contamination level of two (means a normal non-conductive contamination, temporary conductivity due to condensation is possible).

Installation Requirements

3.2

No special precautions are necessary. Mount the equipment in an area which is relatively free of vibration, and has sufficient room for cable connections.

The amplifier has a class II installation category.

Bench Operation

3.2.1

The unit can be placed onto a secure flat surface.

Power Requirements

3.3

The BLA2H500 E Amplifier 400-500MHz has a built-in switched power supply. The mains line connector on the rear panel is a CEI 10A.

One Phase Line requirements :

AC input voltage :	208-230VAC
Input current max :	4,15A
Frequency :	50/60Hz

System Check

3.4

Before applying power for the first time the following items should be checked:

- The AC input voltage 208-230 VAC \pm 10% range must be compatible with the power supply.
- An external blanking (gating) pulse must be supplied to the amplifier in order for the unit to function. Ensure that this pulse has a proper level and logic polarity.
- The BLA2H500 E Amplifier 400-500MHz has a nominal input level of +4dBm. Ensure that the system drivers are operating at these levels.
- Output RF loads are connected.

The following list describes how to turn on the BLA2H500 E Amplifier 400-500MHz and what should be seen as this occurs.

Before starting this procedure, make sure that you have properly followed the instructions in section **"System Check" on page 12.**

1. Connect the amplifier to the AC line and turn the line switch to ON.
2. Observe the indicators on the front panel of the amplifier :
 - The +32V ON LED's will illuminate,
 - The +15V, -15V and +3,3V ON LED's will illuminate.
3. System is now fully operational.

Operation

4

Front Panel Description

4.1

The BLA2H500 E Amplifier 400-500MHz front panel is provided with 2 x 11 indicators for status monitoring, 6 RF connectors, 1 interface connector and 1 line switch.

Indicators

4.1.1

Normal operation is indicated when following LED's are ON.

Table 4.1. Indicators Assignment

+32V	Indicates that the +32V supply is applied.
+15V	Indicates that the +15V supply is applied.
-15V	Indicates that the -15V supply is applied.
+3,3V	Indicates that the +3,3V supply is applied.
Overdrive	Indicates when the peak power limit has been reached.
Duty Cycle (D.C.)	Indicates when the duty cycle limit has been reached.
Pulse Width (P.W.)	Indicates when the pulse width limit has been reached.
Mismatch	Indicates when the max. reflected power limit has been reached.
RF POW. FLT	Indicates when one of the above limits has been reached.
Overheat	Indicates that the thermistor located on the RF module heatsink has sensed excessive heatsink temperature. The amplifier is blanked until an acceptable temperature is reached. The function is self-resetting and no maintenance is needed. Indicates also that a fan on the assembly stops turning. The amplifier is blanked until fans are changed.
H500 ON	Indicates when the RF Power is present on the H1 channel or H2 channel.

Table 4.2. Coaxial Connectors Assignment

IN1, IN2	RF input, SMA type connector (female). Nominal +4dBm drive to deliver full power.
H1 OUT / H2 OUT	RF output, N type connector (female).
BLNK 1 / BLNK 2	Blanking input, BNC type connector (female). TTL logic, 5V = blanking ON, 0V = blanking OFF. When BLANKING signal is at TTL level high (+5V), no gating is applied to the amplifier stages, and no RF Power is possible. When BLANKING signal is at TTL level low (0V), the amplifier stages are gated and RF Power is possible.

The RJ45 connector for the Ethernet 10/100 Mbps link is mounted directly on the BLA Control Board.

Table 4.3. RJ45 Pin Assignment

Pin 1	Transmit + (Tx+)
Pin 2	Transmit - (Tx-)
Pin 3	Receive + (Rx+)
Pin 4	N/A
Pin 5	N/A
Pin 6	Receive - (Rx-)
Pin 7	N/A
Pin 8	N/A

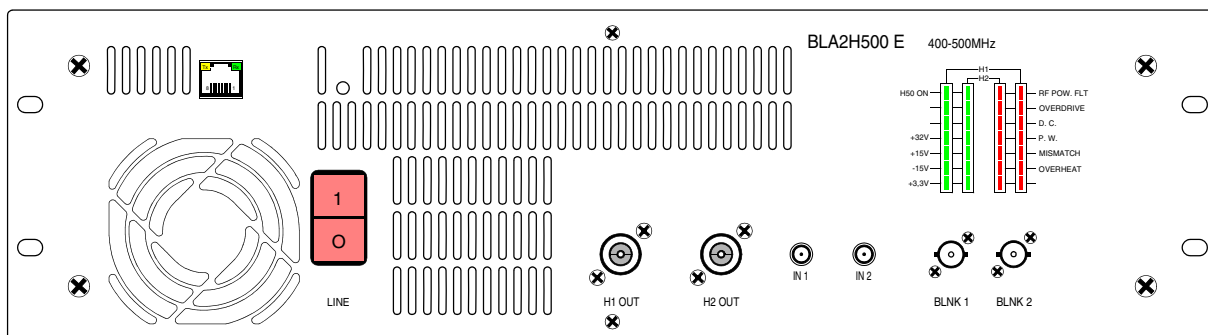

Figure 4.1. BLA2H500 E Amplifier 400-500MHz Front Panel Design



Figure 4.2. BLA2H500 E Amplifier 400-500MHz Front Panel View

Rear Panel Description

4.2

The BLA2H500 E Amplifier 400-500MHz rear panel is free of elements in exception of the 3 poles (2P+E) line filter socket.

Device Rear View

4.2.1

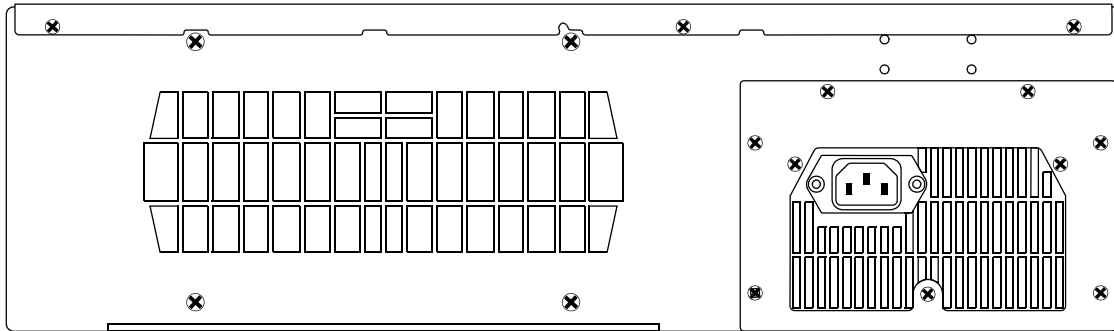

Figure 4.3. BLA2H500 E Amplifier 400-500MHz Rear Panel Design

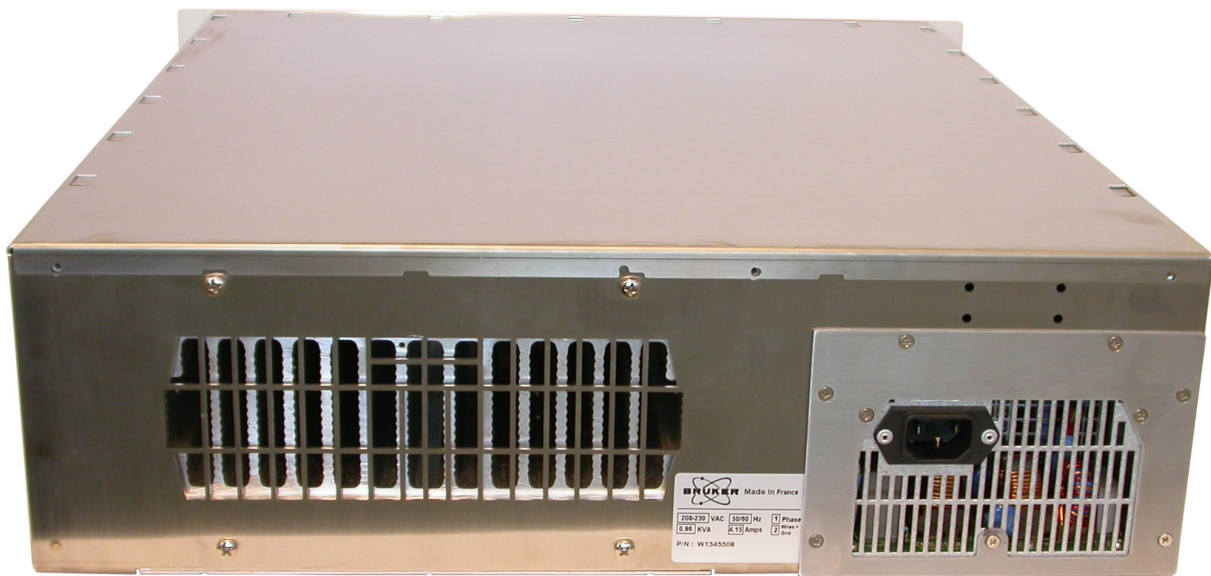

Figure 4.4. BLA2H500 E Amplifier 400-500MHz Rear Panel View

Technical Description

5

System Overview

5.1

The BLA2H500 E Amplifier 400-500MHz provides :

- Two RF Output of 500W and more on the channel output H1 OUT and H2 OUT, over the full frequency range 400 to 500MHz.

The RF section of the system consists of a linear module BLM2H500-E mounted around a single self-contained Push fan assembly heatsink.

The linear module BLM2H500-E is build with two class AB Power Amplifiers. The amplifier for the channel H1 is located on the top side of the module and the one for the channel H2 is on the bottom side.

The both output channels are connected to the front panel of the BLA2H500 E each via an isolator and a bi-directional high dynamic coupler.

The entire system is controlled by a Digital Signal Processing control board, processing information from the amplifier and blanking signal, providing protection from excessive peak power, duty cycle and pulse width for average power, maximum reflected power and heatsink over-temperature.

The DSP control board reads the indentification information of the amplifier (BIS).

Monitoring of fan status, supply status and LED's status is also performed by the control board.

Circuits such as BLAC6 Extension Board 2 Channels and Status LED's board, complete the amplifier assembly.

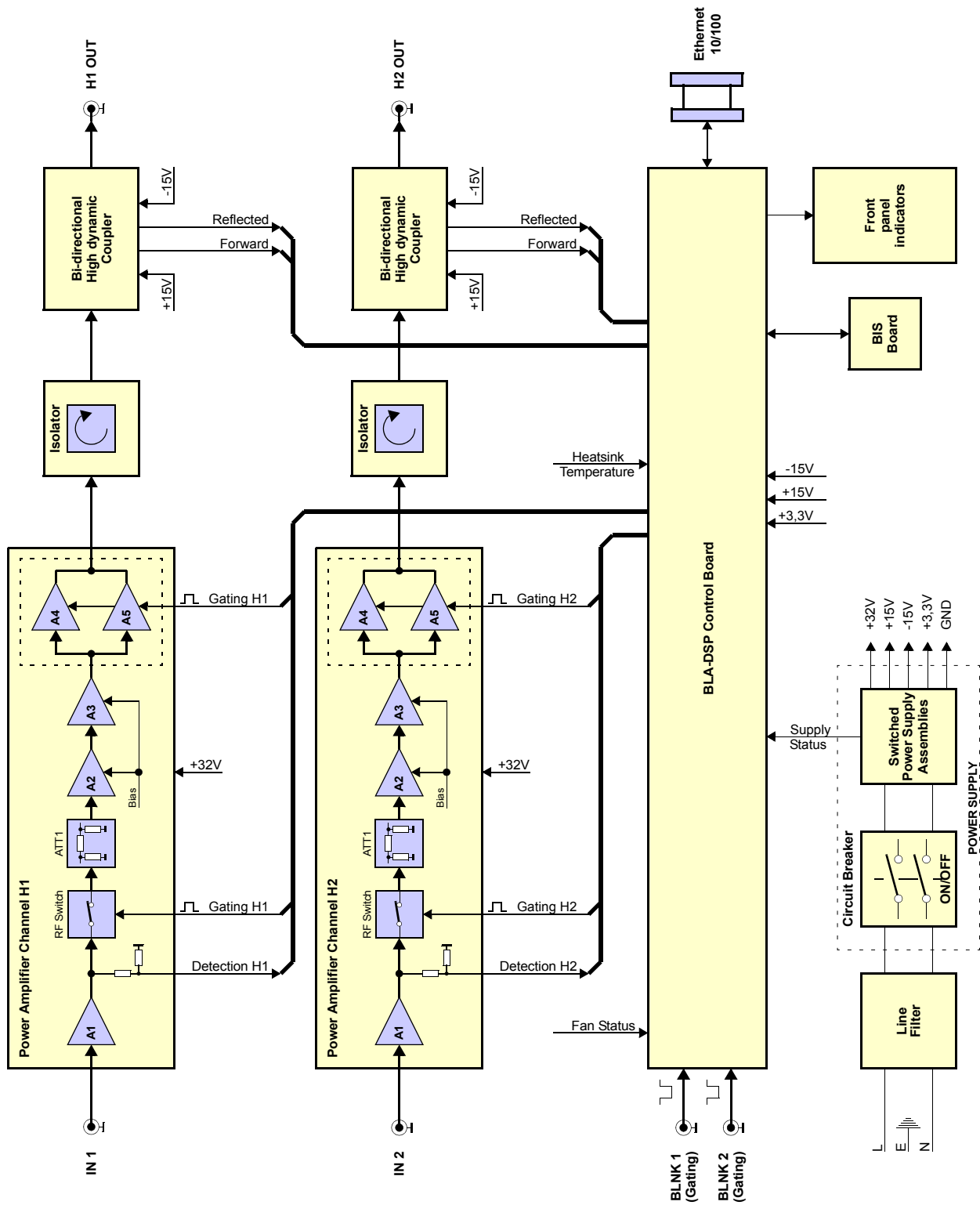

Figure 5.1. BLA2H500 E Amplifier 400-500MHz System Block Diagram

The BLA2H500 E Amplifier 400-500MHz (P/N: W1345508) consists of two class AB power amplifiers.

A nominal input power level of +4dBm produces a rated linear output power of :

- 500W peak for 6% duty cycle at 60ms pulse width maximum on each of the both channel H1 and H2 output.

The unit is also capable of longer pulses for lower average power, up to 30W CW.

RF Power Amplifiers

In the first section of the power amplifiers, the RF input signal is fed directly to a hybrid amplifier and crosses the RF detection path. Then it is conveyed via an AsGa RF Switch to a thermo compensated attenuator (Thermal pad) and two class A drivers to build a nominal 38dB to 40dB gain block.

In this section, only the RF switch requires a control board conditioned gating signal to control the operation of the switching element.

The second section of the power amplifier includes two LDMOSFET transistors.

The circuitry around the transistors consists of complementary input and output transformers and baluns and operates the devices in push-pull.

This section requires a control board conditioned gating signal in order to control the bias gate voltage on the gates of the FETs.

The input-output gain of this section is at nominal 16dB.

The RF power amplifier has a 55dB nominal gain and operates at +32VDC.

RF Couplers

The bi-directional high dynamic couplers on the front panel provide an approximate 1V peak DC signal for full output power and also a peak DC signal for reflected power.

Both signals, forward and reflected, are analyzed by the BLA Control board for monitoring and protection setting.

RF Isolators

The RF isolators are built-in to protect the output power transistors from excessive signal reflection. There is a isolator incorporated between each power output and coupler.

The BLA Control Board has 3 main functions:

1. Conditions the input blanking (BLNK) signal and delivers it to the above mentioned RF Paths.
2. Allows Ethernet communication with the workstation.
3. Monitor the output characteristics of the amplifier thanks to the DC peak detection of the bi-directional high dynamic coupler.
Electronic circuitry processes the detection information and protect the amplifier from overstress like :
 - Forward and reflected peak power

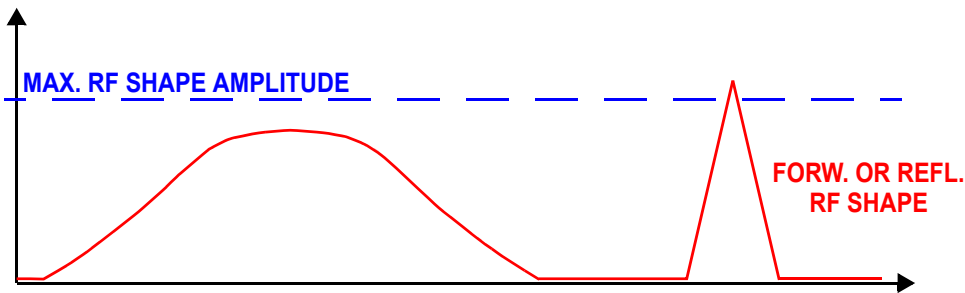

Figure 5.2. Peak Power Limitation

The peak power limitation is the maximum RF forward shape amplitude allowed at the amplifier output.

Limitation range : from 1% to 200% of nominal power.

The peak power limitation is checked for each sample (10 million samples per second), and the maximum peak value is latched then cleared by a read operation (for monitoring purpose).

- Forward pulse width

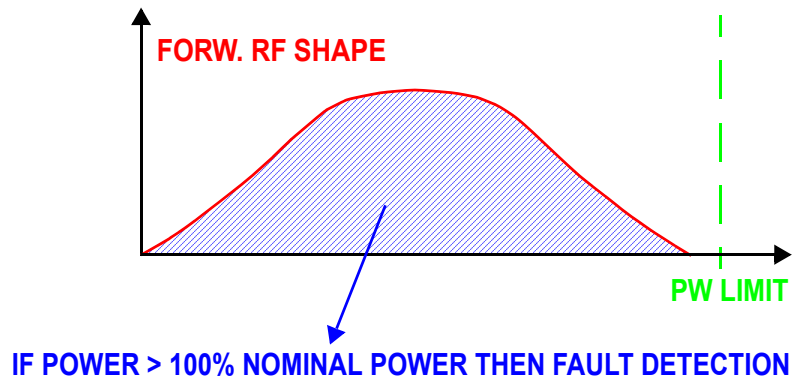

Figure 5.3. Forward Pulse Width Limitation

The pulse width is the lapse of time during which the nominal power can be applied.

Limitation range : from 0.1ms to 512ms.

The pulse width value is updated every 100µs.

- Forward pulse duty cycle

The duty cycle value is the ratio between measured input power during pulse width limitation value divided by duty cycle limitation value and the nominal power during the same time.

For example, if the pulse width limitation is set to 3ms and duty cycle is limited to 10%, then duty cycle value equals the measured input power during 30ms (3ms / 0.1) divided by the nominal power during 30ms.

Limitation range : from 1% to 100%.

The duty cycle value is updated every 100µs.

- Excess of reflected power (Mismatch)

The mismatch value is the ratio between the reflected power value and the forward power value.

Limitation range : from 1% to 100%.

The mismatch value is updated every 100µs.

- Other protections

The control board also detects the following faults :

- Power supply fault
- Fan failure
- Heat sink temperature to protect against thermal overstress
- Fault detection timings

Table 5.1. Fault Detection Timings

Fault	Detection delay (max)
Peak power	500 ns
Duty cycle	100 µs
Pulse Width	100 µs
Mismatch	100 µs
Power Supply, Fan	200 ns
Heat sink temperature	500 ms

Peak, pulse width, duty cycle, mismatch and also mean power values can be read out at any time from the main DSP for monitoring purpose.

- Fault protection reset.

If one of these overstresses appears the board automatically resets the fault flags after 2 seconds, the gating signal is disabled and the status led board on the front panel displays the fault.

Technical Description

This means, for example, that when a pulse width fault occurs, the amplifier channel is disabled after the detection delay. The side effect is that the fault condition disappears since the channel's output power is null.

After 2 seconds, the channel is switched on and the cycle begins again (unless the channel RF input signal is re-adjusted to meet the power limitations).

BLA Extension Board

5.2.3

This board gives the information to the control board of RF detection.

Status Led Board

5.2.4

The status led board, on the front panel of the amplifier, displays overstress functions, supplies status, and so on, as described in **"Indicators" on page 15** and **"BLA Control Board" on page 22**.

BIS Board

5.2.5

The universal BIS board is located on the amplifier case and contains identifications of the amplifier.



[Technical help : please contact your local representative.](#)

Servicing the BLA

6

The BLA2H500 E Amplifier 400-500MHz provides diagnosis and servicing web pages relies on HTTP, allowing service access with any web browser.

Accessing the BLA Amplifier

6.1

The BLA2H500 E Amplifier 400-500MHz is accessible via the BLA control board with its IP address.

The IP address is given during "**cf**" by using TOPSPIN 2.xx software on the workstation.

In case of problems :

- Check the RJ45 cabling between amplifier, Ethernet switch and workstation.
- Check the Ethernet switch power.
- Check if the green LED on the amplifier RJ45 connector lights up.
- Check the front panel of the amplifier, LED's indicators +32V, +15V, -15V and +3.3V ON must have lit.

To access the BLA2H500 E Amplifier 400-500MHz, type "**ha**" in TOPSPIN 2.xx or better and choose the BLA that should be accessed or start your favourite web browser and type the given IP address as URL.

You should get the following start screen.

Bruker Linear Amplifiers

BRUKER

BLA

Information Advanced Operations Maintenance

Information

Amplifier information
Amplifier status

Device Information

Name: BLA2H500 E 400-500MHZ
Part number: W1345508
Serial number: 0001
Ecl: 0
Manufacturing location: BFR
Manufacturing date: 10/19/09
BIS type: BLA

Software Versions

Boot version: 20051018
Kernel version: Windows CE 5.0
Application version: BLAC6_20090311

Channel Information

Ch.	Type	Nom. power	Min freq.	Max freq.	Duty cycle	Pulse width	Limits		Output num.	Input num.
							Mismatch	Forw. peak		
1	H	500 W	400 MHz	500 MHz	6 %	60 ms	250 W (50 %)	1000 W (200 %)	1	1
2	H	500 W	400 MHz	500 MHz	6 %	60 ms	250 W (50 %)	1000 W (200 %)	2	2

think forward

© 2005-2008 Bruker Biospin SA. All rights reserved.

Figure 6.1. Device Information

This page gives you general information about the amplifier (default page).

In the main toolbar, we can see that a BLA is displayed.

The left panel is the navigation menu. It can be used to navigate through the service pages or choose another tab in the sub toolbar.

Leads you to a page giving information about the current status of the amplifier.

Bruker Linear Amplifiers

BLA

Information Advanced Operations Maintenance

Amplifier status

Name: BLA2H500 E 400-500MHZ
 Part number: W1345508
 Serial number: 0001
 Ecl: 0

	Channel 1	Channel 2
Type:	H	H
Nominal power:	500 W	500 W
Forward peak power:	0.00 %	0.00 %
Forward average power:	0.00 %	0.00 %
Reflected power:	0 %	0 %
Overdrive:	OK	OK
Pulse width:	OK	OK
Duty cycle:	OK	OK
Mismatch:	OK	OK
General gating fault:	OK	OK
Supply:	OK	OK
Thermal:	OK	OK
Blanking signal state:	inactive	inactive
Input power:	none	none
Output power:	none	none
High resolution state:	inactive	inactive
Switchbox position:	0xFF	0xFF

This page is automatically refreshed every 10 seconds

© 2005-2008 Bruker Biospin SA. All rights reserved.

Figure 6.2. Amplifier Status

You should get the following start screen.

think forward

Device Information

Name: BLA2H500 E 400-500MHZ
 Part number: W1345508
 Serial number: 0001
 Ecl: 0
 Manufacturing location: BFR
 Manufacturing date: 10/19/09
 BIS type: BLA

Software Versions

Boot version: 20051018
 Kernel version: Windows CE 5.0
 Application version: BLAC6_20090311

Channel Information

Ch.	Type	Nom. power	Min freq.	Max freq.	Limits				Output num.	Input num.
					Duty cycle	Pulse width	Mismatch	Forw. peak		
1	H	500 W	400 MHz	500 MHz	6 %	60 ms	250 W (50 %)	1000 W (200 %)	1	1
2	H	500 W	400 MHz	500 MHz	6 %	60 ms	250 W (50 %)	1000 W (200 %)	2	2

© 2005-2008 Bruker Biospin SA. All rights reserved.

Figure 6.3. Device Information

This page gives you general information about the amplifier.

The left panel is the navigation menu. It can be used to navigate through the service pages or choose another tab in the sub toolbar.

Leads you to a page giving several default and current limits of the amplifier.

If you want, for any reasons, to change the current limits of the amplifier, press **Change limits**.

Bruker Linear Amplifiers

BLA

Information **Advanced Operations** Maintenance

Advanced Operations
Amplifier limitations
Routing information & setting

Amplifier limitations

Name: BLA2H500 E 400-500MHZ
Part number: W1345508
Serial number: 0001
Ed: 1

Channel Information

Channel 1				Limits				Output num.	Input num.
Type	Nom. power	Min freq.	Max freq.	Duty cycle	Pulse width	Mismatch	Forw. peak		
H	500 W	400 MHz	500 MHz	6 %	60 ms	250 W (50 %)	1000 W (200 %)	1	1
Current limits :				6 %	60 ms	250 W	1000 W	Change limits	

Channel 2				Limits				Output num.	Input num.
Type	Nom. power	Min freq.	Max freq.	Duty cycle	Pulse width	Mismatch	Forw. peak		
H	500 W	400 MHz	500 MHz	6 %	60 ms	250 W (50 %)	1000 W (200 %)	2	2
Current limits :				6 %	60 ms	250 W	1000 W	Change limits	

think forward

© 2005-2008 Bruker Biospin SA. All rights reserved.

Figure 6.4. Amplifier Limitations

Read the warnings, change limit parameters and press **Apply** if you are sure of that.



Bruker Linear Amplifiers

BLA

Information **Advanced Operations** Maintenance

Advanced Operations
Amplifier limitations
Routing information & setting

Channel limitations

Name: BLA2H500 E 400-500MHZ
Part number: W1345508
Serial number: 0001
Ecl: 0

Channel 1 limitations

Changing these settings will overwrite the limitations defined with the spectrometer software. Please use this page for test purposes only.

Type :	H			
Nominal power :	500 W			
Min. frequency :	400 MHz			
Max. frequency :	500 MHz			
	Default	Current	New	Maximum
Duty cycle limit :	6 %	6 %	<input type="text" value="6"/> %	6 %
Pulse width limit :	60 ms	60 ms	<input type="text" value="60"/> ms	60 ms
Mismatch limit :	250 W (50 %)	250 W	<input type="text" value="250"/> W	500 W
Forward peak limit :	1000 W (200 %)	1000 W	<input type="text" value="1000"/> W	1000 W
	<input type="button" value="Apply"/>			
Output number :	1			
Input number :	1			

think forward

© 2005-2008 Bruker Biospin SA. All rights reserved.

Figure 6.5. Change Limits (Channel 1)



Bruker Linear Amplifiers

BLA

Information **Advanced Operations** Maintenance

Advanced Operations
Amplifier limitations
Routing information & setting

Channel limitations

Name: BLA2H500 E 400-500MHZ
Part number: W1345508
Serial number: 0001
Ecl: 0

Channel 2 limitations

Changing these settings will overwrite the limitations defined with the spectrometer software. Please use this page for test purposes only.

Type :	H			
Nominal power :	500 W			
Min. frequency :	400 MHz			
Max. frequency :	500 MHz			
	Default	Current	New	Maximum
Duty cycle limit :	6 %	6 %	<input type="text" value="6"/> %	6 %
Pulse width limit :	60 ms	60 ms	<input type="text" value="60"/> ms	60 ms
Mismatch limit :	250 W (50 %)	250 W	<input type="text" value="250"/> W	500 W
Forward peak limit :	1000 W (200 %)	1000 W	<input type="text" value="1000"/> W	1000 W
	<input type="button" value="Apply"/>			
Output number :	2			
Input number :	2			

think forward

© 2005-2008 Bruker Biospin SA. All rights reserved.

Figure 6.6. Change Limits (Channel 2)

Leads you to a page giving information about the current routed RF path at the amplifier inputs.

Default RF path is INPUT 1 to CHANNEL 1 and INPUT 2 to CHANNEL 2.

Bruker Linear Amplifiers

BLA

Information | **Advanced Operations** | Maintenance

Routing Information & Setting

Name: BLA2H500 E 400-500MHZ
 Part number: W1345508
 Serial number: 0001
 Ed: 0

Changing these settings will overwrite the routes defined with the spectrometer software. Please use this page for test purposes only.

Input routing

Input number	Current channel	Possible channels	New route
1	1	1	Fixed route
2	2	2	Fixed route

Output routing

Output number	Current channel	Possible channels	New route
1	1	1	Fixed route
2	2	2	Fixed route

think forward

© 2005-2008 Bruker Biospin SA. All rights reserved.

Figure 6.7. Routing Information and Setting

Because of fixed route, it is not possible to change anything.

You should get the following start screen.

The screenshot shows the Bruker Linear Amplifiers web interface. At the top right is the Bruker logo. Below it is a navigation bar with tabs for 'Information', 'Advanced Operations', and 'Maintenance'. The 'Maintenance' tab is active. On the left is a blue navigation menu with options: 'Maintenance', 'Self test & Software reset', 'Firmware update', and 'BIS content'. The main content area is titled 'Device Information' and contains three sections: 'Device Information' (with fields for Name, Part number, Serial number, Ecl, Manufacturing location, Manufacturing date, and BIS type), 'Software Versions' (with fields for Boot version, Kernel version, and Application version), and 'Channel Information' (a table with columns for Ch., Type, Nom. power, Min freq., Max freq., Duty cycle, Pulse width, Mismatch, Forw. peak, Output num., and Input num.).

Device Information

Name: BLA2H500 E 400-500MHZ
 Part number: W1345508
 Serial number: 0001
 Ecl: 0
 Manufacturing location: BFR
 Manufacturing date: 10/19/09
 BIS type: BLA

Software Versions

Boot version: 20051018
 Kernel version: Windows CE 5.0
 Application version: BLAC6_20090311

Channel Information

Ch.	Type	Nom. power	Min freq.	Max freq.	Limits				Output num.	Input num.
					Duty cycle	Pulse width	Mismatch	Forw. peak		
1	H	500 W	400 MHz	500 MHz	6 %	60 ms	250 W (50 %)	1000 W (200 %)	1	1
2	H	500 W	400 MHz	500 MHz	6 %	60 ms	250 W (50 %)	1000 W (200 %)	2	2

think forward

© 2005-2008 Bruker Biospin SA. All rights reserved.

Figure 6.8. Device Information

This page gives you general information about the amplifier.

The left panel is the navigation menu. It can be used to navigate through the service pages or choose another tab in the sub toolbar.

Leads you to a page allowing you to do a self-test on the BLA control board (Hardware test) and to do a software reset.

Both operations can be done if the amplifier doesn't work correctly.

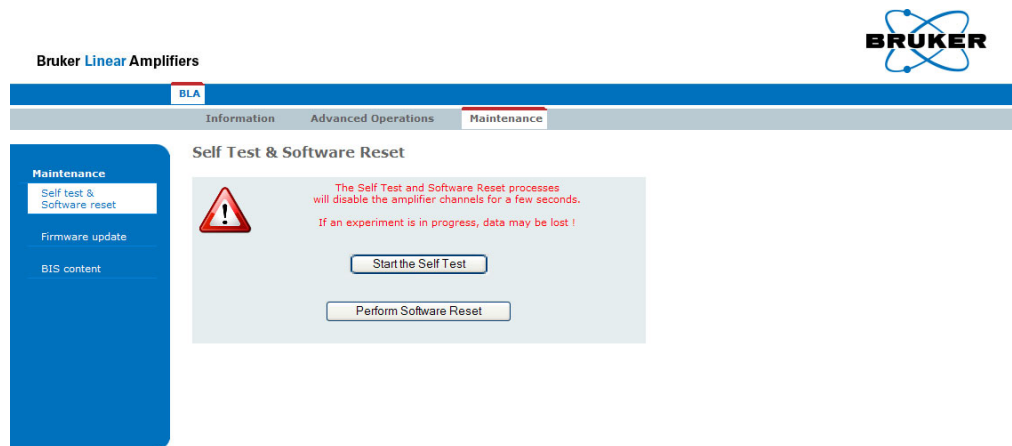

think forward

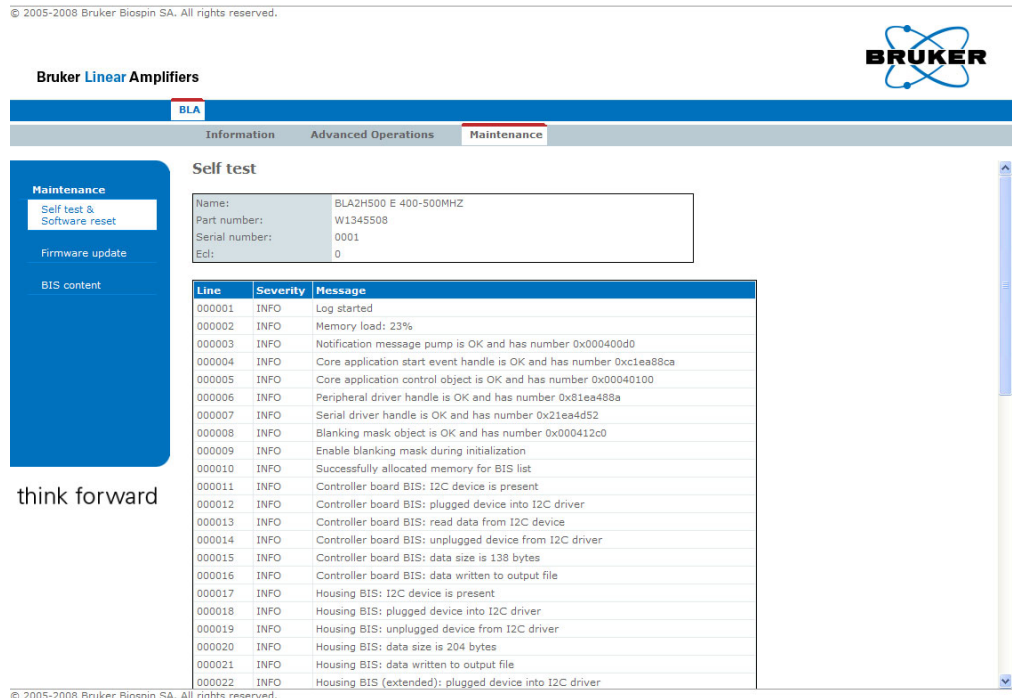

think forward

Figure 6.9. Perform Self Test and Report

Read the warnings, press **Start the Self Test**.

You should have only gray lines in the report.

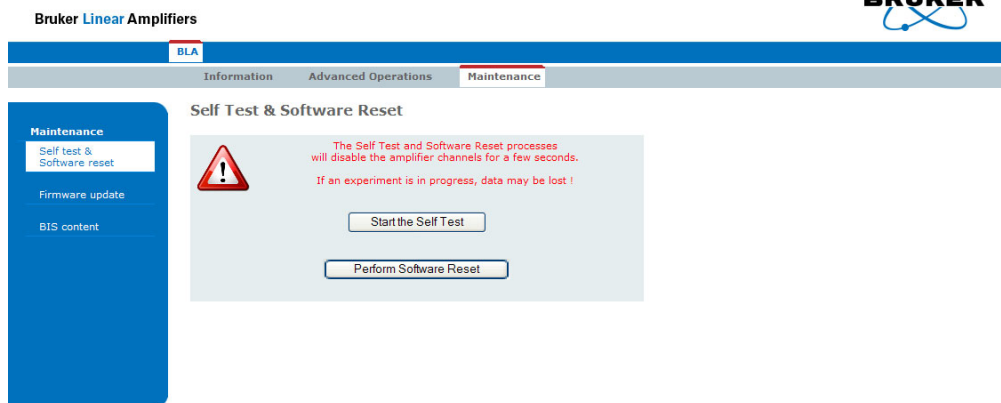

think forward

© 2005-2008 Bruker Biospin SA. All rights reserved.

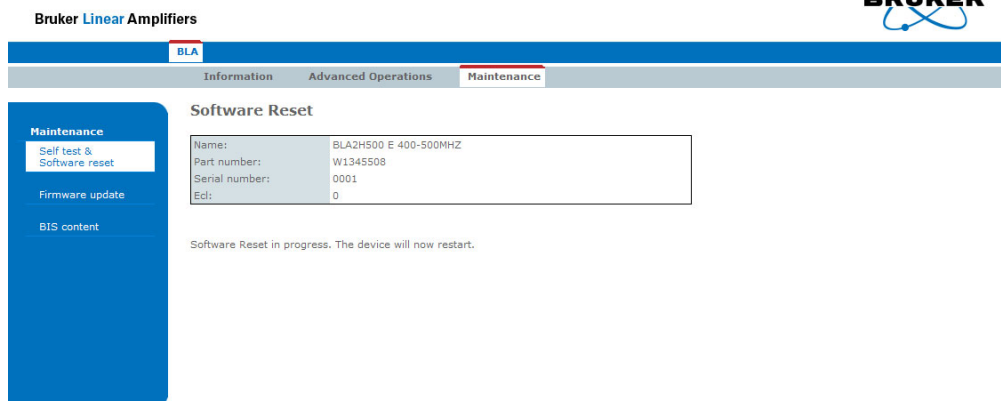

think forward

© 2005-2008 Bruker Biospin SA. All rights reserved.

Figure 6.10. Perform Software Reset and Report

Read the warnings, press **Perform Software Reset**.

You should have the following screen.

Leads you to a page allowing you to download new firmware.

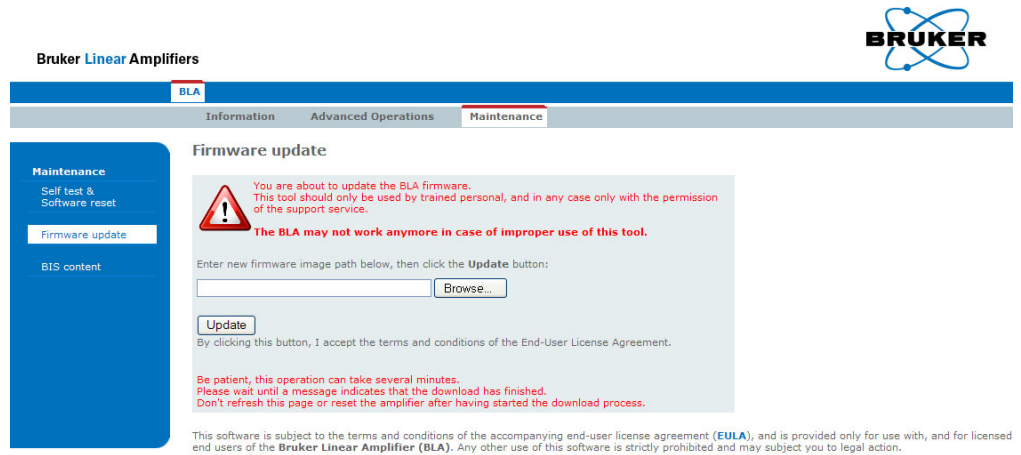

think forward

© 2005-2008 Bruker Biospin SA. All rights reserved.

Figure 6.11. Firmware Update

Read the warnings, press the **Browse** button for selecting the new firmware file to download and press **Update**. Download the new firmware will take a few minutes.



NOTE : This button caption depends on your operating system language settings.

Leads you to a page giving information about the current BIS programmed on the amplifier.

Bruker Linear Amplifiers

BLA | Information | Advanced Operations | Maintenance

Maintenance

- Self test & Software reset
- Firmware update
- BIS content**

BIS Content

BIS Id:	1
BIS description:	BLA Controller
BIS type:	BLAC
BIS content:	<code>\$Bis,1,20071105,2048,BLAC,1# \$Prd,W1522050,4526,2,8D6,20071105# \$Nam,BLA CONTROL BOARD 6 2V H-USB# \$CtrlVers,1,0,6,0# \$EndBis,f6, f2#</code>

BIS Id:	2
BIS description:	BLA Housing
BIS type:	BLA
BIS content:	<code>\$Bis,1,20091019,2048,BLA,3# \$Prd,W1345508,0001,0,,BFR,20091019# \$Nam,BLA2H500 E 400-500MHz# \$Amp,1,1,1,H,,500,F8,6,60,400,500,1,1,50,200,200,# \$Amp,1,1,2,H,,500,F8,6,60,400,500,2,2,50,200,200,# \$EndBis,f4, fcs</code>

think forward

© 2005-2008 Bruker Biospin SA. All rights reserved.

Figure 6.12. BIS Content

Specifications

7

Common Characteristics

7.1

Table 7.1. Amplifier Common Characteristics

Constant Internal Protection	Supplies, fans faults and over temperature. Forward Power : peak & CW power, pulse width and duty cycle. Reflected Power : peak & CW power, self resetting protection shuts the amplifier off if the load VSWR is excessive.
Front Panel Indicators	Amplifier Status Led Board.
Front Panel Interfaces	1 x I/O 8 pins RJ45 connector.
Front Panel Controls	1 x AC line ON/OFF switch.
Front Panel Connectors	2 x RF input, 2 x RF output, 2 x blanking input (gating).
Rear Panel Connectors	1 x AC line in socket.
Cooling System	Forced-air cooling (from front to rear).
Size	19" rack cabinet x 3U height x 520mm depth.
Weight	19kg
Power Requirements	208-230 VAC \pm 10% single phase 50-60Hz. Bruker Biospin part number W1304006. Consumption max. 0.96kVA.

Specifications

General Specifications

7.2

Channel H1 and H2 500W Output

7.2.1

Table 7.2. Channel H1 and H2 500W Output Specifications

Frequency Range	400 to 500MHz
Linear Gain	55dB \pm 1dB typical
Gain Flatness	\pm 1dB max.
Minimum Pulsed Output Power (@ nominal Input +4dBm)	500W min. full range
CW Output Power (Internal Limitation)	30W max.
Linear Output Power	450W typical @ 1dB compression
Linearity	+2 / -1dB to 450W typical
Amplifier Biasing	Class AB operation
Blanking Delay Time	1 μ s min.
RF Rise Time	< 100ns
RF Fall Time	< 50ns
DC Ringing	\pm 100mV typical (due to blanking signal)
Input Noise Figure	5dB typical
Output Noise Power (Unblanked)	-112dBm @ 1Hz
Output Noise Power (Blanked)	Thermal Noise
Input/Output Impedance	50 Ω
Input V.S.W.R.	1.6 : 1 max.
Output Harmonics (2fc ; 3fc)	-45dBc ; -30dBc max. @ 500W
Pulse Width (Internal Limitation)	60ms @ 500W (up to CW @ 30W)
Duty Cycle (Internal Limitation)	6% @ 500W (up to 100% @ 30W)
Droop & Pulse Flatness	\pm 3% typical @ 500W for 100ms Pulse Width
Amplitude Stability vs. Temperature	\pm 0.1% / $^{\circ}$ C max.

Service Information and Maintenance

8

Every intervention on the device must be carried out by an authorized and qualified person. Any failure due to a non-respect of the following instructions will not be attributable to BRUKER BIOSPIN and will not be covered by the guarantee clauses.

Preventive Maintenance of the RF Module on BLA-Type Amplifiers

8.1

The RF module inside BLA's Amplifiers is equipped with a easily extractible PUSH FAN Assembly.

Fan's on assembly have a high reliability and manufacturer gives a expected live time of 70000 hours (8 years) at 25°C and 5 years at 60°C.

Replacement of the assembly could be done in the field when a misfonction of fans is detected by lightning from the OVERHEAT Status Led.

To prevent such a misfonction, a preventive maintenance could be done every 4 years.

This assembly can be ordered on the manufactory BBIO-FR by P/N:

- **W1346523** «PUSH FAN ASSEMBLY 6».

Operation

8.1.1

1. Disconnect all cables from the front panel and the supply connector on the rear panel. Remove the amplifier from the NMR console and place it on a secure flat surface.
2. Unscrew and remove the coverage plate from the amplifier.
3. Disconnect the 2 wires (red +32V / black GND) being on the RF module dispatch supply connectors and coming from the Push fan assembly. Also disconnect the fan status wires (white) from BLA Control board connector J18.

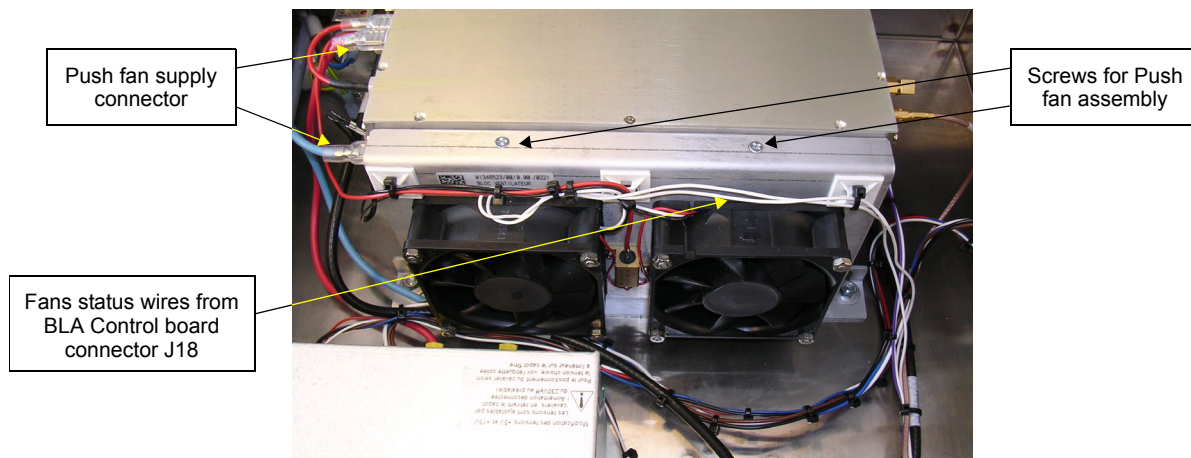

Figure 8.1. Push Fan Assembly

4. Unscrew the 2 screws on the top of the Push fan assembly.
5. Remove the Push fan assembly.
6. Place correctly the new fan assembly in the bottom holes of the RF module and screw it on the top.
7. Connect all wires (status and supply).
8. Connect line cord and turn on the amplifier. Note that the fans are turning and no OVERHEAT status led appears on front panel.
9. Put the coverage plate on the amplifier and screw it.
10. Put the amplifier in the NMR console, connect all cables on the front panel and the line cord on the rear panel.

Figures

1 General Information	5
2 Safety	7
Figure 2.1. Identifying Plate	7
Figure 2.2. Manufacturer's Name Plate	8
3 Installation	11
4 Operation	15
Figure 4.1. BLA2H500 E Amplifier 400-500MHz Front Panel Design	17
Figure 4.2. BLA2H500 E Amplifier 400-500MHz Front Panel View	17
Figure 4.3. BLA2H500 E Amplifier 400-500MHz Rear Panel Design	18
Figure 4.4. BLA2H500 E Amplifier 400-500MHz Rear Panel View	18
5 Technical Description	19
Figure 5.1. BLA2H500 E Amplifier 400-500MHz System Block Diagram	20
Figure 5.2. Peak Power Limitation	22
Figure 5.3. Forward Pulse Width Limitation	22
6 Servicing the BLA	25
Figure 6.1. Device Information	26
Figure 6.2. Amplifier Status	27
Figure 6.3. Device Information	28
Figure 6.4. Amplifier Limitations	29
Figure 6.5. Change Limits (Channel 1)	30
Figure 6.6. Change Limits (Channel 2)	30
Figure 6.7. Routing Information and Setting	31
Figure 6.8. Device Information	32
Figure 6.9. Perform Self Test and Report	33
Figure 6.10. Perform Software Reset and Report	34
Figure 6.11. Firmware Update	35
Figure 6.12. BIS Content	36
7 Specifications	37
8 Service Information and Maintenance	39
Figure 8.1. Push Fan Assembly	40

Tables

1 General Information	5
2 Safety	7
3 Installation	11
4 Operation	15
Table 4.1. Indicators Assignment	15
Table 4.2. Coaxial Connectors Assignment	16
Table 4.3. RJ45 Pin Assignment	16
5 Technical Description	19
Table 5.1. Fault Detection Timings	23
6 Servicing the BLA	25
7 Specifications	37
Table 7.1. Amplifier Common Characteristics	37
Table 7.2. Channel H1 and H2 500W Output Specifications	38
8 Service Information and Maintenance	39



End of Document

Bruker BioSpin, your solution partner

Bruker BioSpin provides a world class, market-leading range of analysis solutions for your life and materials science needs.

● **Bruker BioSpin Group**

info@bruker-biospin.com
www.bruker-biospin.com

