

BLA

- Upgrade Controller
Operating and Service Manual
Version 002



Copyright © by Bruker Corporation

All rights reserved. No part of this publication may be reproduced, stored in a retrieval system, or transmitted, in any form, or by any means without the prior consent of the publisher. Product names used are trademarks or registered trademarks of their respective holders.

This manual was written by

Serge Brzuczkiewicz

© September 18, 2014 Bruker BioSpin

P/N: Z31826

DWG: Z4D10434-02

For further technical assistance for this product, please do not hesitate to contact your nearest BRUKER dealer or contact us directly at:

Bruker BioSpin
34, rue de l'Industrie
67166 WISSEMBOURG Cedex
France
Phone: + 33 3 88 06 60 60
FAX: + 33 3 88 06 60 05
E-mail: hmagnets.service@bruker.fr
Internet: www.bruker.com

Contents

1	About This Manual.....	5
1.1	This Manual.....	5
1.2	Policy Statement.....	5
1.3	Symbols and Conventions.....	5
2	General Information.....	7
2.1	Introduction.....	7
3	Safety.....	9
3.1	Labels.....	9
3.1.1	Identifying Plate.....	9
3.1.2	Manufacturer's Nameplate	10
3.1.3	Warning Signs.....	11
4	Installation.....	13
4.1	Initial Inspection.....	13
4.1.1	Mechanical Check.....	13
4.1.2	Claim for Damage.....	13
4.1.3	Reshipment and Repackaging Requirements.....	13
4.1.4	Environment Requirements.....	13
4.2	Installation Requirements.....	14
4.2.1	Bench Operation.....	14
4.3	Power Requirements.....	14
4.4	System Check.....	14
4.5	Initial Turn on Procedure.....	14
5	Operation.....	15
5.1	Front Panel.....	15
5.1.1	Indicators	15
5.1.2	Coaxial Connectors.....	15
5.1.3	Interface Connector Ethernet 10/100.....	16
5.1.4	Device Design.....	16
5.1.5	Rear Panel.....	17
6	Technical Description.....	19
6.1	System Overview.....	19
6.2	Theory of Operation.....	20
6.2.1	RF Path and Detectors.....	20
6.2.2	BLA Control Board.....	20
6.2.3	Ethernet Controller.....	20
7	Servicing the BLA Upgrade Controller.....	21
7.1	Accessing the BLA Upgrade Controller.....	21
7.1.1	Device Status.....	22
7.1.2	Routing Information.....	23
7.1.3	Self-Test & Software Reset.....	24
7.1.4	BIS Content.....	25

Contents

7.1.5	Firmware Update.....	25
7.1.6	Channel Configuration.....	26
8	Specifications.....	29
8.1	General Specifications.....	29
9	Contact.....	31
	List of Figures.....	33
	List of Tables.....	35

1 About This Manual

This manual is intended to be a reference guide for operators and service technicians. It provides detailed information about the user level maintenance and service, as well as overall use of the Bruker device.

Before starting any work, personnel must read the manual thoroughly and understand its contents. Compliance with all specified safety and operating instructions, as well as local accident prevention regulations, are vital to ensure safe operation.

The figures shown in this manual are designed to be general and informative and may not represent the specific Bruker model, component or software/firmware version you are working with. Options and accessories may or may not be illustrated in each figure.

1.1 This Manual

1.2 Policy Statement

It is the policy of Bruker to improve products as new techniques and components become available. Bruker reserves the right to change specifications at any time.

Every effort has been made to avoid errors in text and figure presentation in this publication. In order to produce useful and appropriate documentation, we welcome your comments on this publication. Support engineers are advised to regularly check with Bruker for updated information.

Bruker is committed to providing customers with inventive, high quality products and services that are environmentally sound.

1.3 Symbols and Conventions

Safety instructions in this manual are marked with symbols. The safety instructions are introduced using indicative words which express the extent of the hazard.

In order to avoid accidents, personal injury or damage to property, always observe safety instructions and proceed with care.

DANGER



DANGER indicates a hazardous situation which, if not avoided, will result in death or serious injury.

This is the consequence of not following the warning.

1. This is the safety condition.
 - ▶ This is the safety instruction.

WARNING



WARNING indicates a hazardous situation, which, if not avoided, could result in death or serious injury.

This is the consequence of not following the warning.

1. This is the safety condition.
 - ▶ This is the safety instruction.

CAUTION



CAUTION indicates a hazardous situation, which, if not avoided, may result in minor or moderate injury.

This is the consequence of not following the warning.

1. This is the safety condition.
 - ▶ This is the safety instruction.

NOTICE

NOTICE indicates a property damage message.

This is the consequence of not following the notice.

1. This is a safety condition.
 - ▶ This is a safety instruction.

SAFETY INSTRUCTIONS

SAFETY INSTRUCTIONS are used for control flow and shutdowns in the event of an error or emergency.

This is the consequence of not following the safety instructions.

1. This is a safety condition.
 - ▶ This is a safety instruction.



This symbol highlights useful tips and recommendations as well as information designed to ensure efficient and smooth operation.

2 General Information

2.1 Introduction

The BLA Upgrade Controller is an upgrade box for the adaptation of older versions (< AVANCE III) of BRUKER RMN and MRI amplifiers and others too, to the new IPSO console.

- The box is 19" x 1U x 460mm. It has an internal power supply.
- The communication with the console is done via Ethernet.
- The controller can emulate one or two BLA channels.
- The emulated channel characteristics are setup via the embedded service web pages. This implies that no specific software is needed to perform this operation, a web browser is sufficient.
- The firmware for the Upgrade Controller is the same as for the standard BLA E Amplifiers.

The BLA Upgrade Controller is commercialized under the BRUKER BIOSPIN Part Number W1345502.

3 Safety

The BLA Upgrade Controller is in accordance with the standard 61010-1 safety Requirements for Electrical Equipments.

3.1 Labels

Labels are provided to alert operating and service personnel to conditions that may cause personal injury or damage to the equipment from misuse or abuse. Please read the labels and understand their meaning.

3.1.1 Identifying Plate

The BLA Upgrade Controller can be identified by an identifying plate at the front panel of the unit that has following information.

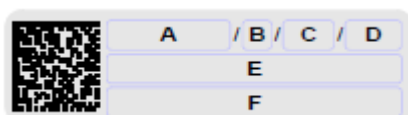

Figure 3.1: Identifying Plate

- (A) Part Number
This field indicates the part number of the product.
- (B) Variant
This field indicates the variant number that identifies the production category of the product. The default variant is 00.
- (C) ECL
This field indicates the revision number that identifies the product configuration. The initial revision is 0.00.
- (D) Serial Number
This field indicates the serial number of the product.
- (E) Type
This field contains the designation of the product.
- (F) Information
This field contains additional information about the product.

3.1.2 Manufacturer's Nameplate

The BLA Upgrade Controller can be identified by a manufacturer's nameplate at the back panel of the unit that has following information:

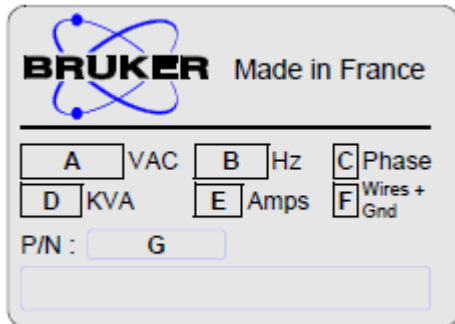

Figure 3.2: Figure 2.2. Manufacturer's nameplate

- (A) Voltage

This field indicates the input mains voltage of the product.

- (B) Frequency

This field indicates the input mains frequency of the product.

- (C) Phases

This field indicates the number of phases of the mains.

- (D) Power

This field indicates the absorbed power of the product.

- (E) Current

This field indicates the absorbed current of the product.

- (F) Wires

This field indicates number of wires with the ground in the mains cord.

- (G) Part Number

This field indicates the assembly number that identifies the part number of the product.

Labels

3.1.3 Warning Signs

 **WARNING****Risk of electrical shocks**

If the equipment is used in a manner not specified by BRUKER, the protection provided by the equipment may be impaired.

- ▶ Please disconnect line cord before opening or prevent potential hazards such as:
 - ⇒ Electric shock on power supply.
 - ⇒ Contact burn with the heatsink.

If the equipment is used in a manner not specified by BRUKER, the protection provided by the equipment may be impaired.

4 Installation

The installation of the device must be done only by an authorized and qualified technician, in total accordance with the running standards. Every breakdown due to a non-respect of the following instructions will not be attributable to Bruker and will not be covered by the guarantee clauses.

4.1 Initial Inspection

4.1.1 Mechanical Check

If damage of the shipping carton is evident, request the carrier's agent to be present when the instrument is unpacked. Check the equipment for damage and inspect the cabinet and panel surfaces for dents and scratches.

4.1.2 Claim for Damage

If the unit is mechanically damaged or fails to meet specifications upon receipt, notify BRUKER or our representative immediately. Retain the shipping carton and packing material for the carriers inspection as well as for subsequent use in returning the unit if necessary.

4.1.3 Reshipment and Repackaging Requirements

Whenever possible, the original carton and packing material should be used for reshipment. If the original packing material is not available, wrap the instrument in heavy paper or plastic. Use a strong shipping container. If a cardboard is used, it should be at least 200 lbs. test material.

Use shock absorbing material around all sides of the instrument to provide a firm cushion and to prevent from movements inside the container wall on each side. Protect the front panel by means of cardboard spacers inserted between the front panel and the shipping carton. Make sure that the instrument cannot move in the container during shipping. Seal the carton with a good grade of shipping tape and mark the container :

" FRAGILE ELECTRONIC INSTRUMENT."

4.1.4 Environment Requirements

This controller is built for inside use only on a maximum high level of 2000m above sea level (6600 feet).

No specific cooling or ventilation is required.

Be sure that the controller has enough area around so that the free air flow into and out of the controller is not obstruct.

It should, however, be in an environment which conforms to the 5°C - 45°C (41°F - 113°F) thermal specifications, a 80% maximum relative humidity of air and a contamination level of 2 (means a normal only non conductive contamination, temporary conductivity due to condensation is possible).

4.2 Installation Requirements

No special precautions are necessary. Mount the equipment in an area which is relatively free of vibration, and has sufficient room for cable connections.

The amplifier is a class II of installation category.

4.2.1 Bench Operation

The unit can be placed onto a secure flat surface.

4.3 Power Requirements

The controller is designed with a built-in switched power supply. The main line connector is a CEI 10A.

One Phase Line requirements:

AC input voltage: 90-264VAC

Input current maximum: 0.7A

Inrush current maximum: 30A

Frequency: 47-440Hz

4.4 System Check

Before applying power for the first time the following items should be checked:

- The AC input voltage must be compatible with the power supply (90-264VAC).
- An external blanking (gating) pulse must be supplied to the controller in order the unit to function. Ensure that this pulse has a proper level and logic polarity.
- The internal blanking (gating) output has the same polarity as the blanking input and goes to the amplifier input
- The controller has a nominal input level of +4dBm. Ensure that the system drivers are operating at these levels.
- Check the RJ45 connection between Upgrade Controller, the Ethernet switch and the workstation. Initial turn on procedure
- Check the Ethernet switch power.

4.5 Initial Turn on Procedure

The following list describes how to turn on the BLA Upgrade Controller and what should be seen as this occurs.

Before starting this procedure, make sure that you have properly followed instructions in the section [System Check \[▶ 14\]](#).

1. Set the circuit breaker to ON so it is lighted.
2. After initialization (a few seconds), the controller LED on the front panel READY is ON.
3. The green LED on the amplifier RJ45 connector lights up.
4. The system is now fully operational and the 2 channels for emulating the amplifiers channels are ready.

5 Operation

5.1 Front Panel

The BLA Upgrade Controller front panel is provided with 1 power on switch with red ON light, 1 ready green LED indicator, 2 RF input SMA connectors, 2 RF output SMA connectors, 2 blanking input BNC connectors, 2 blanking output BNC connectors and 1 Ethernet interface RJ45 connector.

5.1.1 Indicators

Normal operation is indicated when following light and LED are ON.

Functions	Descriptions
READY	Green LED indicates that the controller is ok.
POWER ON	Red light in ON/OFF switch indicates that the AC supply is applied.

Table 5.1: Indicators assignment

5.1.2 Coaxial Connectors

Connectors	Descriptions
I1, I2	RF nominal inputs +4dBm, SMA type connector (female).
O1, O2	RF nominal outputs +4dBm, SMA type connector (female).
BLK1 IN, BLK2 IN	Blanking signals, BNC type connector (female). TTL logic, 5V = blanking ON, 0V = blanking OFF. When blanking signal is at TTL level high (+5V), no gating is applied to the amplifier stages, and no RF Power is possible. When blanking signal is at TTL level low (0V), the amplifier stages are gated and RF Power is possible.
BLK1 OUT, BLK2 OUT	Blanking signals, BNC type connector (female). TTL logic, 5V = blanking ON, 0V = blanking OFF. When blanking signal is at TTL level high (+5V), no gating is applied to the amplifier stages, and no RF Power is possible. When blanking signal is at TTL level low (0V), the amplifier stages are gated and RF Power is possible.

Table 5.2: Coaxial RF and blanking connectors assignment

5.1.3 Interface Connector Ethernet 10/100

The RJ45 connector for the Ethernet 10/100 Mbps link is mounted directly on the controller interface board.

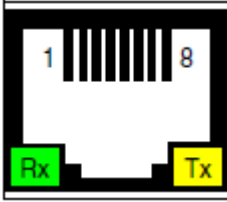

Figure 5.1: RJ45 8 Pin Connector

Pins	Descriptions	Pins	Descriptions
1	Transmit + (Tx+)	4	N/A
2	Transmit - (Tx-)	5	N/A
3	Receive + (Rx+)	6	Receive - (Rx-)

Table 5.3: RJ45 8 pin connector assignment

5.1.4 Device Design

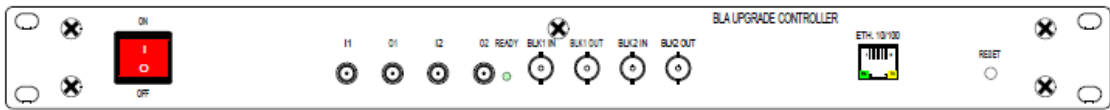

Figure 5.2: BLA Upgrade Controller Front Panel Design



Figure 5.3: BLA Upgrade Controller Front Panel View

5.1.5 Rear Panel

The rear Panel of the BLA Upgrade Controller is free of elements in exception of the three pole (2P + E) line filter socket.



Figure 5.4: BLA Upgrade Controller Rear Panel View

6 Technical Description

6.1 System Overview

The BLA Upgrade Controller supports 2 amplifier channels.

It needs the RF inputs and blanking inputs for detecting the RF routing.

The RF signal is available at the RF output and the blanking is available at the blanking output.

The communication with the console is done with the Ethernet interface. It allows to technical description of the amplifiers connected to the controller.

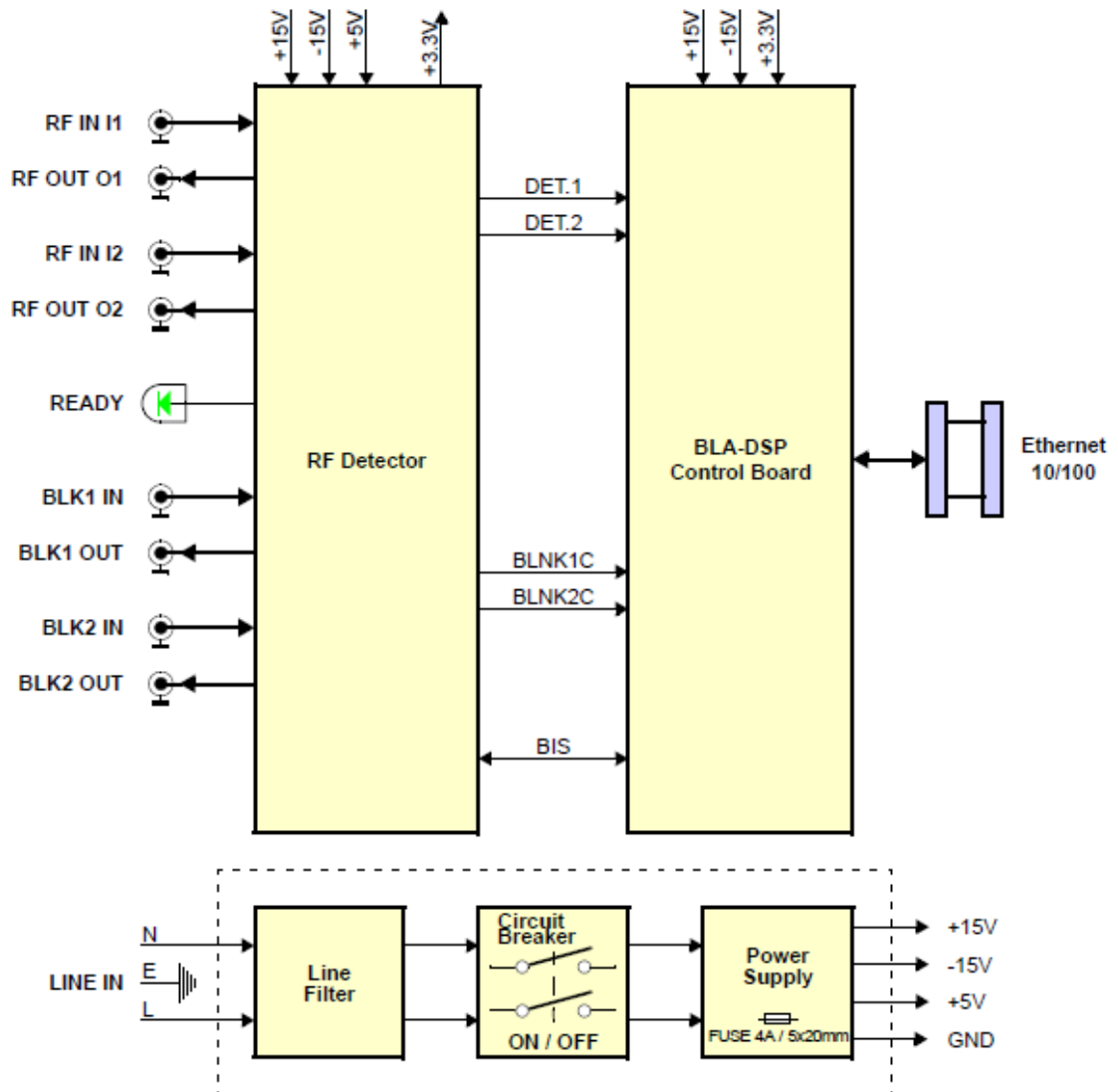

Figure 6.1: BLA Upgrade Controller System Block Diagram

6.2 Theory of Operation

6.2.1 RF Path and Detectors

The RF signals and blanking goes through the BLA Upgrade Controller only for checking the RF routing.

6.2.2 BLA Control Board

The CPU unit manages the information of the channel, BIS and amplifier specifics. A Reset button may be used for reinitializing the control board on the front panel.

6.2.3 Ethernet Controller

The Ethernet Controller communicates with the spectrometer.



IMPORTANT: The operating of the Ethernet link requires a Spectrometer Management Software such as TopSpin.

7 Servicing the BLA Upgrade Controller

Configuration, diagnosis and servicing access to the BLA Upgrade Controller relies on HTTP, allowing service access with any web browser.

7.1 Accessing the BLA Upgrade Controller

The BLA Upgrade Controller is accessible via the BLA control board with its IP address.

The IP address is given during **cf** by using TopSpin 2.xx software on the workstation.

To access the BLA Upgrade Controller, type **ha** in TopSpin 2.xx and choose the BLA that should be accessed or start your favorite web browser and type the given IP address as URL.

You should get the following start screen.

The screenshot shows the Bruker BLA Service Web interface. The main content area is titled "Bruker Linear Amplifier Device Information". It contains several sections:

- Amplifier information**: A sidebar menu with options like "Amplifier status", "Routing information", "Self test & Software reset", "BIS content", "Firmware update", and "Channel configuration".
- Device Information**: A table with fields for Name, Part number, Serial number, Ecl, Manufacturing location, Manufacturing date, and BIS type.
- Software versions**: A table with fields for Boot version, Kernel version, and Application version.
- Channel Information**: A table with columns for Ch., Type, Nom. power, Min freq., Max freq., Duty cycle, Pulse width, Limits (Mismatch, Forw. peak), Output num., and Input num.
- High Resolution Option Information**: A table with columns for Ch., Nom. power, Duty cycle, Pulse width, Limits (Mismatch, Forw. peak), and Output num.

© 2005-2008 Bruker Biospin SA. All rights reserved.

Figure 7.1: Device Information

The left panel is the navigation menu. It can be used to navigate through the service pages.

7.1.1 Device Status

Leads you to a page which gives information about the current status of the different channels of the controller.

BRUKER BLA Service Web

Bruker Linear Amplifier
Amplifier status

Amplifier information	Name: BLA UPGRADE CONTROLLER	
Amplifier status	Part number: W1345502	
Routing information	Serial number: 0001	
Self test & Software reset	Ecl: 0	
BIS content		
Firmware update		
Channel configuration		

	Channel 1	Channel 2
Type:	X	H
Nominal power:	1000 W	1000 W
HR output power:	300 W	100 W

Blanking signal state: inactive inactive
Input power: none none

This page is automatically refreshed every 10 seconds

© 2005-2008 Bruker Biospin SA. All rights reserved.

Figure 7.2: Amplifier status

7.1.2 Routing Information

Leads you to a page giving information about the current routed RF path at the upgrade controller inputs and outputs.

BRUKER BLA Service Web

Bruker Linear Amplifier
Routing Information & Setting

Name: BLA UPGRADE CONTROLLER
Part number: W1345502
Serial number: 0001
Ed: 0

Warning : Changing these settings will overwrite the routes defined with the spectrometer software. Please use this page for test purposes only.

Input number	Current channel	Possible channels	New route
1	1	1	Fixed route
2	2	2	Fixed route

© 2005-2008 Bruker Biospin SA. All rights reserved.

Figure 7.3: Routing information

In a BLA Upgrade Controller the routing is fixed.

- Input 1 to Output 1.
- Input 2 to Output 2.

7.1.3 Self-Test & Software Reset

Leads you to a page allowing you to do a self-test on the BLA control board (Hardware test), and to do a software reset.

Both operations can be done if the BLA Upgrade Controller doesn't work correctly.

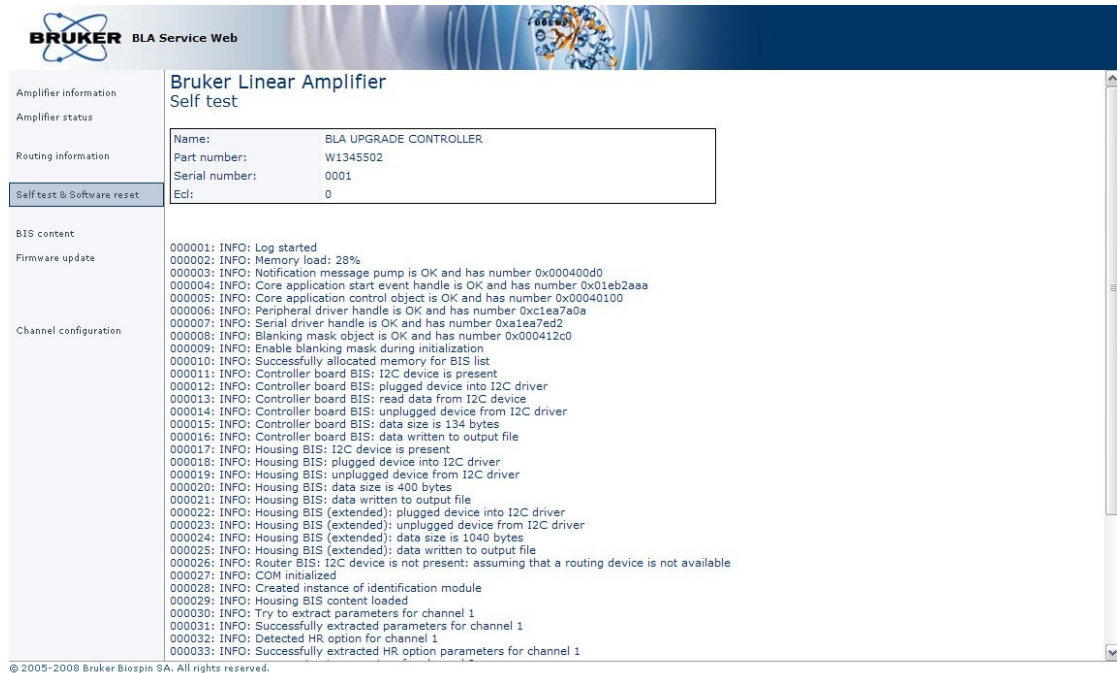
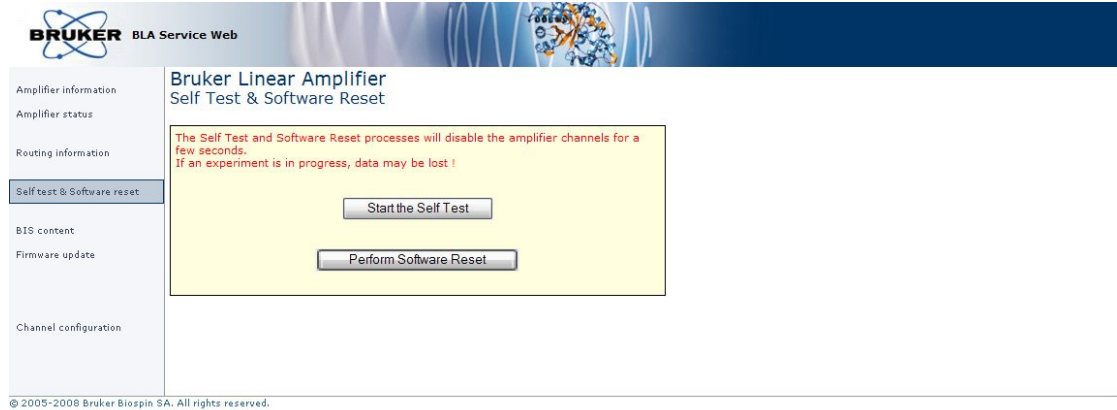

Figure 7.4: Self-test and report

Read the warnings, press **Start the self-test**. You should have only blue lines in the report.

7.1.4 BIS Content

Leads you to a page giving information about the current BIS programmed on the upgrade controller.

BRUKER BLA Service Web

Bruker Linear Amplifier
BIS Content

BIS Id:	1
BIS description:	BLA Controller
BIS type:	BLAC
BIS content:	\$Bis,1,20050913,2048,BLAC,1# \$Prd,W1522040,0018,0,,BFR,20050913# \$Nam,BLA CONTROL BOARD 6 2CH V-USB# \$CtrlVers,1.0,6.0# \$EndBis,47,86#

BIS Id:	2
BIS description:	BLA Housing
BIS type:	BLA
BIS content:	\$Bis,1,20071214,2048,BLA,3# \$Prd,W1345502,0001,0,,BFR,20071214# \$Nam,BLA UPGRADE CONTROLLER# \$Amp,1,1,2,H,,1000.00,18.5.00,100.00,180.00,600.00,1,1,50.00,200.00,200.00,1# \$HROpt,1,0,2,,100.00,20.00,100.00,180.00,600.00,2,50.00,200.00,200.00# \$Amp,1,1,1,W,1000.00,,18.5.00,100.00,6.00,365.00,3,2,50.00,200.00,200.00,1# \$HROpt,1,0,1,300.00,,10.00,100.00,6.00,365.00,4,50.00,200.00,200.00# \$EndBis,37,5e#

© 2005-2008 Bruker Biospin SA. All rights reserved.

Figure 7.5: BIS Content

7.1.5 Firmware Update

Leads you to a page allowing you to download new firmware.

BRUKER BLA Service Web

Bruker Linear Amplifier
Firmware update

You are about to update the BLA firmware.
This tool should only be used by trained personal, and in any case only with the permission of the support service.

The BLA may not work anymore in case of improper use of this tool.

Enter new firmware image path below, then click the **Update** button:

By clicking this button, I accept the terms and conditions of the End-User License Agreement.

Be patient, this operation can take several minutes.
Please wait until a message indicates that the download has finished.
Don't refresh this page or reset the amplifier after having started the download process.

This software is subject to the terms and conditions of the accompanying end-user license agreement (**EULA**), and is provided only for use with, and for licensed end users of the **Bruker Linear Amplifier (BLA)**. Any other use of this software is strictly prohibited and may subject you to legal action.

© 2005-2008 Bruker Biospin SA. All rights reserved.

Figure 7.6: Firmware Update

Servicing the BLA Upgrade Controller

Read the warnings, press the **Browse** button for selecting the new firmware file to download and press **Update**. Download the new firmware will take a few minutes.



NOTE: This button caption depends on your operating system language settings.

7.1.6 Channel Configuration

This page is used to configure the two amplifiers channels emulated by the upgrade controller. The following interface is displayed

Figure 7.7: Channel Configuration

The page is divided in two parts, one for each emulated channel. Please note that the channel numbers on this page refers to the upgrade controller signal input/ output numbering and not to the "real" channel numbers inside their respective housings.



Note: These parameters are "simulated" parameters which may be different from the actual parameters of the physical transmitters. The latter cannot be changed via the BLA Upgrade Controller box.

The configuration of the emulated channels can be changed by following these steps:

- Click on the link **Configure this channel by selecting another amplifier template** in the column corresponding to the upgrade controller channel to be configured. The next page is displayed.



IMPORTANT: If changes were made in the channel settings the "Save changes" button must be clicked before selecting a new amplifier template. Otherwise all channel settings changes will be lost.

BRUKER BLA Service Web

Bruker Linear Amplifier
Upgrade Controller : Amplifier template selection for channel 1

Name: BLA UPGRADE CONTROLLER
Part number: W1345502
Serial number: 0001
Edi: 0

PN	Type	Ch.	Power	Min freq.	Max Freq	HR
CUSTOM	BB	1	1000 W	15 MHz	- 400 MHz	
W1345065	H	1	1000 W	650 MHz	- 900 MHz	Yes
W1345068	X	1	1000 W	6 MHz	- 365 MHz	Yes
W1345073	H	1	1000 W	180 MHz	- 600 MHz	Yes
W1345076	X	1	1000 W	6 MHz	- 405 MHz	Yes
W1345086	BB	1	1000 W	15 MHz	- 400 MHz	Yes

© 2005-2008 Bruker Biospin SA. All rights reserved.

Figure 7.8: Amplifier Template Selection

- The template is chosen by clicking on the channel number of the amplifier part number to emulate.



Note: HR transmitters are transmitters which have a high power output (e.g. Solid) and a low power output (e.g. High Resolution). Example of HR transmitters: BLAX1000 and BLAH1000.



Note: If an amplifier channel without HR option has to be emulated (e.g. for a non Bruker amplifier), the user can choose the "CUSTOM" amplifier part number. The channel characteristics can then be adjusted later (see the next step).



Note: An amplifier with a HR output is seen as an "one channel amplifier". Such a device will consequently only consume one upgrade controller channel. This means that only one upgrade controller is sufficient to emulate two amplifiers with HR outputs.



IMPORTANT: The changes will take effect immediately, in other words the previous channel configuration will be lost as soon as the channel is clicked. In order to cancel the change, the "previous page" button of the web browser must be used before clicking on the channel number.

- After applying the template, the channel configuration page (see [Channel Configuration \[▶ 26\]](#)) is displayed again. The channel characteristics can now be adjusted if needed.



Note: By clicking the **Save changes** button the changes will be saved for both emulated channels.



Note: If one or more values are out of range (see the most right column for the allowed ranges), they will be displayed in red after clicking the **Save changes** button. If this happens no changes will be applied at all, even if all the values are valid for one of the channels.



IMPORTANT: After clicking the **Save changes** button, all the settings will be saved, there is consequently no way to get back the previous settings if needed.

- If an upgrade controller channel is not used, it must be disabled by clicking on the link **Disable this channel**. If this operation is not done, the **cf** command in TopSpin will fail.



Note: The two channels cannot be disabled at the same time. This is why the "Disable this channel" disappears when there is only one channel which is enabled.

- In order for the changes to take effect in the spectrometer system, a **cf** command must be executed in TopSpin.

8 Specifications

8.1 General Specifications

Frequency range	5 to 1000MHz
Insertion Losses	< 0.2dB
Maximum Input Power	+8dBm max.
IN / OUT Impedance	50Ω
Input V.S.W.R.	1,2 max.
Output Harmonics (2nd order)	-45dBc
Output Harmonics (3rd order)	-45dBc
Amplitude Droop	< ±0.5% max.
Amplitude stability versus temperature	< ±0.05% / °C

Table 8.1: BLA Upgrade Controller RF specifications

AC Input Voltage	90-264V
Frequency	47-440Hz
AC Input Current	0.08A (230V)
AC Input Power	20VA
In rush current	30A (230V)
Leakage current	< 0.75mA
AC Fuse	4A 250V

Table 8.2: AC Power Supply

Voltage	+5V, +15V, -15V
Current DC	5A (+5V), 2.3A (+15V), 0.5A (-15V)

Table 8.3: Internal DC Power Supply

Front Panel Indicator	Controller Ready
Front Panel Interfaces	1 x I/O 8 pins RJ45 connector,
Front Panel controls	AC Line ON / OFF
Front Panel connectors	2 x RF input, 2 x RF output, 2 x gating input, 2 x gating output
Rear Panel Interface	AC Line in socket
Cooling System	Free air convection
Temperature limits	+5°C to +45°C
Size	19" rack cabinet x 1U height x 460mm depth
Weight	5.7kg

Table 8.4: BLA Upgrade Controller Common Specifications

9 Contact

Manufacturer

Bruker BioSpin

34, rue de l'Industrie

67166 WISSEMBOURG Cedex

France

Phone: + 33 3 88 06 60 60

Fax: + 33 3 88 06 60 05

<http://www.bruker.com>

E-mail: hmagnets.service@bruker.fr

Please refer to the Model No., Serial No. and Internal Order No. in all correspondence regarding the NMR system or components thereof.

List of Figures

Figure 3.1:	Identifying Plate.....	9
Figure 3.2:	Figure 2.2. Manufacturer's nameplate.....	10
Figure 5.1:	RJ45 8 Pin Connector.....	16
Figure 5.2:	BLA Upgrade Controller Front Panel Design.....	16
Figure 5.3:	BLA Upgrade Controller Front Panel View.....	16
Figure 5.4:	BLA Upgrade Controller Rear Panel View.....	17
Figure 6.1:	BLA Upgrade Controller System Block Diagram.....	19
Figure 7.1:	Device Information.....	21
Figure 7.2:	Amplifier status.....	22
Figure 7.3:	Routing information.....	23
Figure 7.4:	Self-test and report.....	24
Figure 7.5:	BIS Content.....	25
Figure 7.6:	Firmware Update.....	25
Figure 7.7:	Channel Configuration.....	26
Figure 7.8:	Amplifier Template Selection.....	27

List of Tables

Table 5.1:	Indicators assignment.....	15
Table 5.2:	Coaxial RF and blanking connectors assignment.....	15
Table 5.3:	RJ45 8 pin connector assignment.....	16
Table 8.1:	BLA Upgrade Controller RF specifications.....	29
Table 8.2:	AC Power Supply.....	29
Table 8.3:	Internal DC Power Supply.....	29
Table 8.4:	BLA Upgrade Controller Common Specifications.....	29



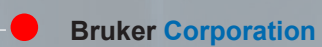

Bruker Corporation

info@bruker.com
www.bruker.com

Order No: Z31826