



Bruker BioSpin

# BLAXH300/100 E •

Amplifier 200-600 MHz  
Operating & Service Manual

Version 002

The information in this manual may be altered without notice.

BRUKER accepts no responsibility for actions taken as a result of use of this manual. BRUKER accepts no liability for any mistakes contained in the manual, leading to coincidental damage, whether during installation or operation of the instrument. Unauthorised reproduction of manual contents, without written permission from the publishers, or translation into an other language, either the entire manual or a part of it, is forbidden.

This manual describes the units as they are at the date of printing. On request, the manufacturer shall supply circuit diagrams, lists of components, descriptions, calibrating instructions and any other information for use by qualified personnel of the user, in charge of repairing the parts of the unit which have been stated by the manufacturer to be "repairable". Such supply shall in no event constitute permission to modify or repair the units or approval of the same.

All rights reserved for the units, circuits, processes and appellations mentioned herein.

This unit is not designed for any type of use which is not specifically described in this manual. Such use may be hazardous.

This manual was written by

**GEISSERT Bernard**

© November 21, 2007: Bruker Biospin SA

Wissembourg, France

P/N: Z31785

DWG-Nr: Z4D10059A

# Contents

	<b>Contents .....</b>	<b>iii</b>
<b>1</b>	<b>General Information .....</b>	<b>5</b>
1.1	Introduction .....	5
<b>2</b>	<b>Safety .....</b>	<b>7</b>
2.1	Labels .....	7
	Identifying plate .....	7
	Manufacturer's nameplate .....	8
2.2	Safety labels and symbols .....	9
	Warning signs .....	9
<b>3</b>	<b>Installation .....</b>	<b>11</b>
3.1	Initial inspection .....	11
	Mechanical check .....	11
	Claim for damage .....	11
	Reshipment and repackaging requirements .....	11
	Environment requirements .....	12
3.2	Installation requirements .....	12
	Bench operation .....	12
3.3	System check .....	12
3.4	Initial turn on procedure .....	12
<b>4</b>	<b>Operation .....</b>	<b>13</b>
4.1	Front Panel .....	13
	Indicators .....	13
	Coaxial Connectors .....	14
	Interface Connector Ethernet 10/100 .....	14
	Accessory Connector .....	14
	Device Design .....	15
4.2	Rear panel .....	16
<b>5</b>	<b>Technical description .....</b>	<b>17</b>
5.1	System Overview .....	17
5.2	Theory of operation .....	20
	RF Path .....	20
	BLA Control Board .....	21
	BLA Extension Board .....	21
	Status Led Board .....	22
	BIS Board .....	22

<b>6</b>	<b><i>Servicing the BLA</i></b> .....	<b>23</b>
6.1	Accessing the BLA amplifier .....	23
	Amplifier status .....	25
	Amplifier limitations .....	26
	Routing information .....	28
	Self-test & software reset .....	29
	BIS content .....	31
	Firmware update .....	32
<b>7</b>	<b><i>Specifications</i></b> .....	<b>33</b>
7.1	General specifications .....	33
<b>8</b>	<b><i>Service information and maintenance</i></b> .....	<b>37</b>
8.1	Preventive maintenance of the RF module on BLA-type Amplifiers.....	37
	Operation .....	37
	<b><i>Figures</i></b> .....	<b>39</b>
	<b><i>Tables</i></b> .....	<b>41</b>

# General Information

# 1

## Introduction

## 1.1

The BLAXH300/100 E is a linear broadband pulse power amplifier specifically designed for Nuclear Magnetic Resonance (NMR) and Magnetic Resonance Imaging (MRI) applications from 4,7 to 14 Teslas Systems. It is commercialized under the BRUKER part number W1345083.

Operating linear class AB, it provides 300W peak power output over the frequency range 6-365MHz on the X channel output and 140W peak power output over the frequency range 220 to 564MHz (100W for 180 to 220MHz and at 600MHz) on the H channel output.

The amplifier is realized by employing N-CHANNEL MOS BROADBAND RF POWER FETs of the latest generation. The unit can provide full power for any combination of pulse width / duty cycle up to 100ms / 25% for the H100 channel and 100ms / 10% for the X300 channel.

Its built-in protection circuitry will allow lower power pulses for longer pulse widths and duty cycles, maintaining a 30W X channel and a 35W H channel average power.

An electronic protection circuitry has been designed to protect against:

- Excessive power output level (overdrive)
- Excessive pulse repetition rate (over duty-cycle protection)
- Excessive pulse duration (over pulse-width)
- More than 50% reflected RF power (mismatch when  $VSWR \geq 6$ )
- Thermal overload (overheat).

The amplifier is powered by an internal switched power supply assembly that provides the +32VDC for the power amplifiers, in addition to all low level voltages for the system.

The supply is self protecting for overcurrent and overvoltage.

The entire unit is housed in a 19", 3U, 520mm rack cabinet.





---

The BLAXH300/100 E Amplifier 200-600MHz is in accordance with the standard 61010-1 safety Requirements for Electrical Equipments.

---

## Labels

## 2.1

Labels are provided to alert operating and service personnel to conditions that may cause personal injury or damage to the equipment from misuse or abuse. Please read the labels and understand their meaning.

### Identifying plate

### 2.1.1

The BLAXH300/100 E 200-600MHz can be identified by an identifying plate at the front panel of the unit that has following information.

Figure 2.1. Identifying plate

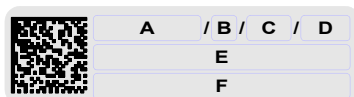

- **(A) Part Number**  
This field indicates the part number of the product.
- **(B) Variant**  
This field indicates the variant number that identifies the production category of the product. The default variant is 00.
- **(C) ECL**  
This field indicates the revision number that identifies the product configuration. The initial revision is 0.00.
- **(D) Serial Number**  
This field indicates the serial number of the product.
- **(E) Type**  
This field contains the designation of the product.
- **(F) Information**  
This field contains additional information about the product.

The BLAXH300/100 E 200-600MHz can be identified by a manufacturer's nameplate at the back panel of the unit that has following information:

Figure 2.2. Manufacturer's nameplate

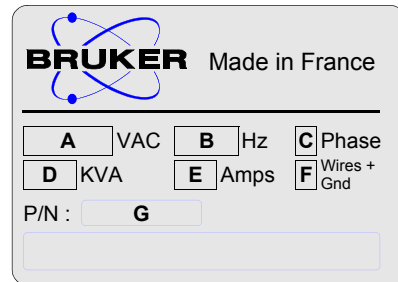

- **(A) Voltage**  
This field indicates the input mains voltage of the product.
- **(B) Frequency**  
This field indicates the input mains frequency of the product.
- **(C) Phases**  
This field indicates the number of phases of the mains.
- **(D) Power**  
This field indicates the absorbed power of the product.
- **(E) Current**  
This field indicates the absorbed current of the product.
- **(F) Wires**  
This field indicates number of wires with the ground in the mains cord.
- **(G) Part Number**  
This field indicates the assembly number that identifies the part number of the product.



### Safety labels and symbols

2.2

#### Warning signs

2.2.1



**WARNING!** Risk of electrical shocks

Figure 2.3. General hazard symbol



Operating personal should not remove RF output cables without turn off the power supply because the RF output power can cause serious burns before the "Mismatch" protection is active.

Please disconnect line cord before opening or prevent potential hazards such as:

- Electric shock on power supply.
- Contact burn with the RF module and heatsink.
- Finger scratch due to the fan assembly on the RF module.



# Installation

# 3

The installation of the device must be done only by an authorized and qualified technician, in total accordance with the running standards. Every breakdown due to a non-respect of the following instructions will not be attributable to Bruker and will not be covered by the guarantee clauses.

## ***Initial inspection***

**3.1**

---

### ***Mechanical check***

**3.1.1**

---

If damage of the shipping carton is evident, request the carrier's agent to be present when the instrument is unpacked. Check the equipment for damage and inspect the cabinet and panel surfaces for dents and scratches.

### ***Claim for damage***

**3.1.2**

---

If the unit is mechanically damaged or fails to meet specifications upon receipt, notify BRUKER or our representative immediately. Retain the shipping carton and packing material for the carriers inspection as well as for subsequent use in returning the unit if necessary.

### ***Reshipment and repackaging requirements***

**3.1.3**

---

Whenever possible, the original carton and packing material should be used for reshipment. If the original packing material is not available, wrap the instrument in heavy paper or plastic. Use a strong shipping container. If a cardboard is used, it should be at least 200 lbs. test material.

Use shock absorbing material around all sides of the instrument to provide a firm cushion and to prevent from movements inside the container wall on each side. Protect the front panel by means of cardboard spacers inserted between the front panel and the shipping carton. Make sure that the instrument cannot move in the container during shipping. Seal the carton with a good grade of shipping tape and mark the container :

**" FRAGILE ELECTRONIC INSTRUMENT."**

# Installation

## **Environment requirements**

**3.1.4**

This amplifier is build for inside use only on a maximum high level of 2000m above sea level (6600 feet).

No specific cooling or ventilation is required.

Be sure that the amplifier has enough area around so that the free air flow into and out of the amplifier is not obstruct.

It should, however, be in an environment which conforms, the 5°C - 45°C (41°F - 113°F) thermal specifications, a 80% maximum relative humidity of air and a contamination level of 2 (means a normal, only non conductive contamination, temporary conductivity due to condensation is possible).

## **Installation requirements**

**3.2**

No special precautions are necessary. Mount the equipment in an area which is relatively free of vibration, and has sufficient room for cable connections.

The amplifier is a class II of installation category.

## **Bench operation**

**3.2.1**

The unit can be placed onto a secure flat surface.

## **System check**

**3.3**

Before applying power for the first time the following items should be checked:

- The AC input voltage 220-230 VAC  $\pm$  15% range must be compatible with.
- An external blanking (gating) pulse must be applied to the amplifier in order for the unit to function. Ensure that this pulse has a proper level and logic polarity.
- The BLAXH300/100 E has a nominal input level of +4dBm. Ensure that the system drivers are operating at these levels.

## **Initial turn on procedure**

**3.4**

The following list describes how to turn on the BLAXH300/100 E and what should be seen as this occurs.

Before starting this procedure, make sure that you have properly followed instructions in the section **"System check"**.

1. Connect the amplifier to the AC line and turn the circuit breaker to ON.
2. Observe the indicators on the front panel :
  - The +32V ON LED's will illuminate
  - The +15V, -15V and +3,3V ON LED's will illuminate
3. System is now fully operational.

# Operation

# 4

## Front Panel

## 4.1

The BLAXH300/100 E front panel is provided with 2 x 11 indicators for status monitoring, 7 RF connectors and 2 interface connectors.

### Indicators

### 4.1.1

Normal operation is indicated when following LED's are ON.

Table 4.1. Indicators assignment

+32V	Indicates that the +32V supply is applied.
+15V	Indicates that the +15V supply is applied.
-15V	Indicates that the -15V supply is applied.
+3,3V	Indicates that the +3,3V supply is applied.
Overdrive	Indicates when the peak power limit has been reached.
Duty Cycle (D.C.)	Indicates when the duty cycle limit has been reached.
Pulse Width (P.W.)	Indicates when the pulse width limit has been reached.
Mismatch	Indicates when the max. reflected power limit has been reached.
RF POW. FLT	Indicates when one of the above limits has been reached.
Overheat	Indicates that the thermistor located on the RF module heatsink has sensed excessive heatsink temperature. The amplifier is blanked until an acceptable temperature is reached. The function is self-resetting and no maintenance is needed. Indicates also that a fan on the assembly stops turning. The amplifier is blanked until fans are changed.
Channel ON	Indicates when the RF Power is present on the H channel or X channel.

Table 4.2. Coaxial Connectors assignment

IN 1, IN 2, IN 3	RF inputs of the embedded router, SMA type connector (female). Default entries are : - IN 1 to channel H and allows the channel to deliver full power at nominal +4dBm drive. - IN 2 to channel X and allows the channel to deliver full power at nominal +4dBm drive.
X OUT / H OUT	RF output N type connector (female).
BLNK X / BLNK H	Blanking signals of channel X or H, BNC type connector (female). TTL logic, 5V = blanking ON, 0V = blanking OFF. When BLANKING signal is at TTL level high (+5V), no gating is applied to the amplifier stages, and no RF Power is possible. When BLANKING signal is at TTL level low (0V), the amplifier stages are gated and RF Power is possible.

The RJ45 connector for the Ethernet 10/100 Mbps link is mounted directly on the BLA Control Board.

Table 4.3. RJ45 Pin assignment

Pin 1	Transmit + (Tx+)
Pin 2	Transmit - (Tx-)
Pin 3	Receive + (Rx+)
Pin 4	N/A
Pin 5	N/A
Pin 6	Receive - (Rx-)
Pin 7	N/A
Pin 8	N/A

Depending of the probe model, this connector makes it possible to connect the QNP accessory.

This accessory (BRUKER part number W1345201) is reconized by "cf" and allows automatic routing to the probe.

Figure 4.1. BLAXH300/100 E Front Panel Design

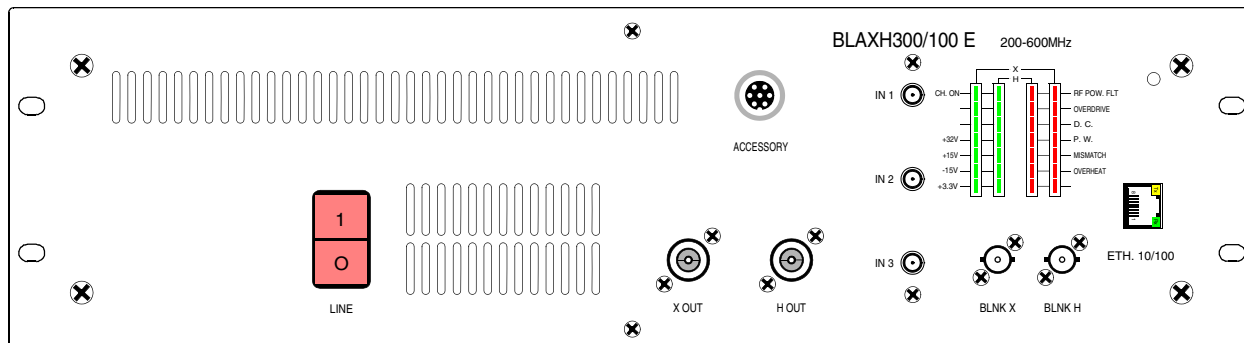
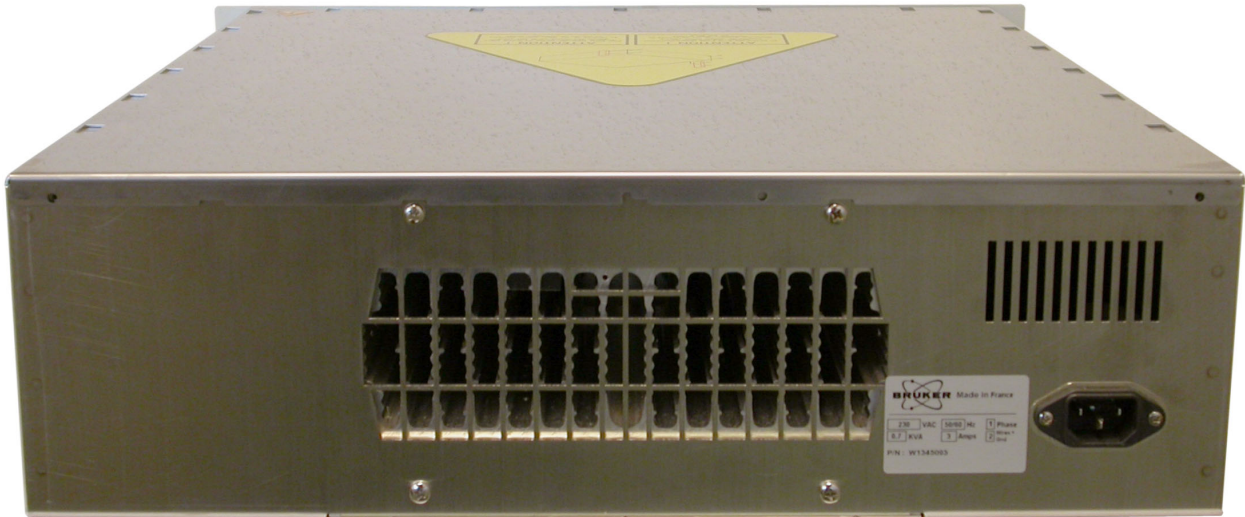

Figure 4.2. BLAXH300/100 E Front Panel View



The rear Panel of the BLAXH2H E Serie Amplifiers is free of elements in exception of the three pole (2P + E) line filter socket.

Figure 4.3. BLAXH300/100 E Rear Panel View





The BLAXH300/100 E amplifier provides :

- A RF Output of 300W on the X channel Output X OUT, over the full frequency range 6 to 365MHz.
- A RF Output of 140W on the H channel Output H OUT, over the full frequency range 200 to 564MHz ( also 100W from 180 to 220MHz and at 600MHz).

The RF section of the system consists of an embedded router fixed on the front panel and a linear module BLMXH300/100-E, mounted around a single, self-contained Push fan assembly, heatsink.

The embedded router has three RF inputs and two outputs respectively wired to channel H and channel X located on the BLMXH300/100-E module.

The linear module BLMXH300/100-E includes two class AB power amplifiers. The amplifier for the H channel is located on the top side of the module and the one for the X channel on the bottom side.

X and H channel outputs are connected to the front panel of the amplifier via a bi-directional high dynamic coupler.

The entire system is tied together by a Digital Signal Processing control board, processing information from the amplifier and blanking signal, providing protection to X and H channels from excessive peak power, duty cycle and pulse width for average power, maximum reflected power and heatsink overtemperature.

The DSP control board reads identification information of the amplifier (BIS). Monitoring of Fan status, Supply status & LED status is also performed by the control board.

Figure 5.1. BLAXH300/100 E System Block Diagram

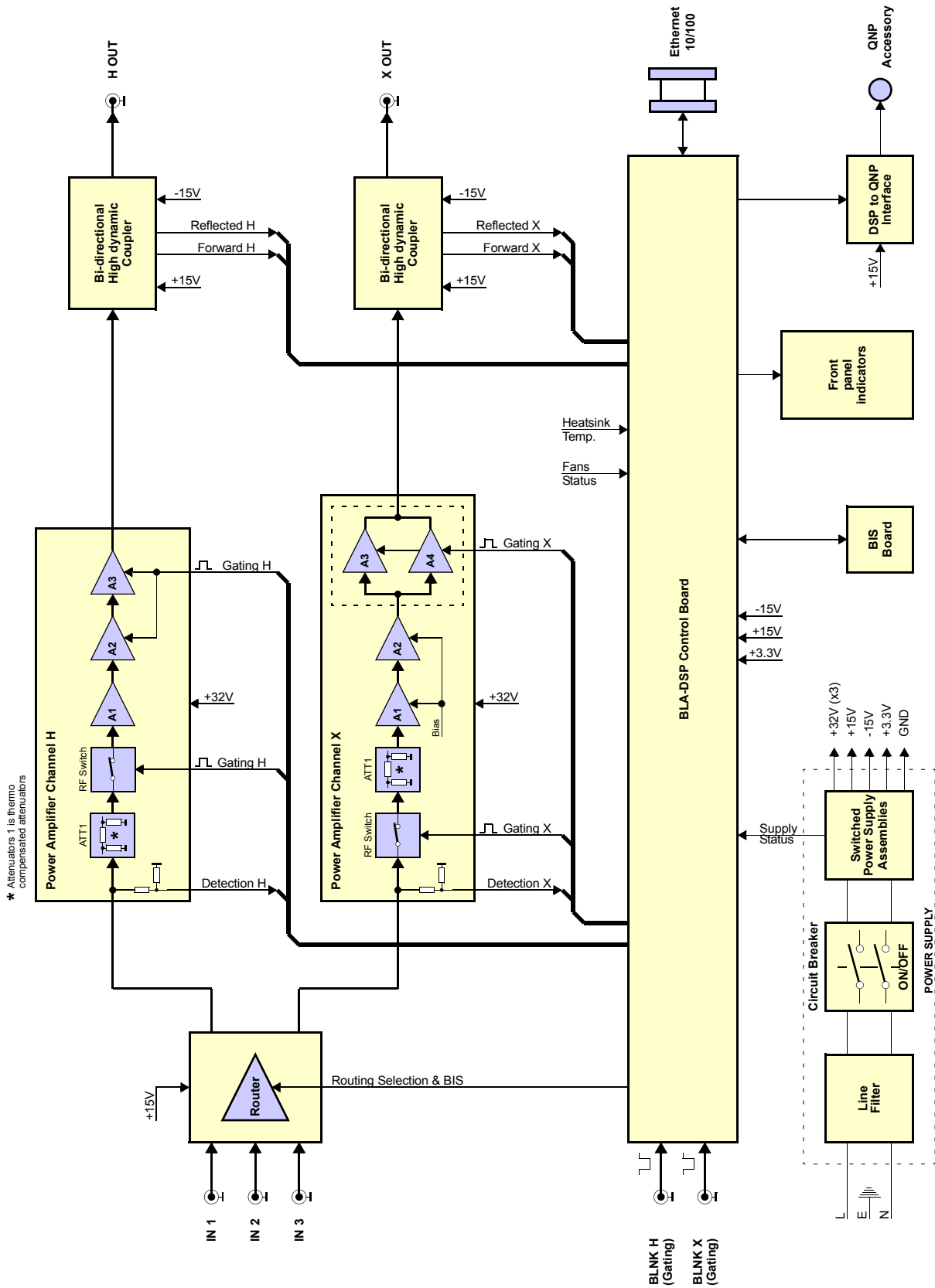
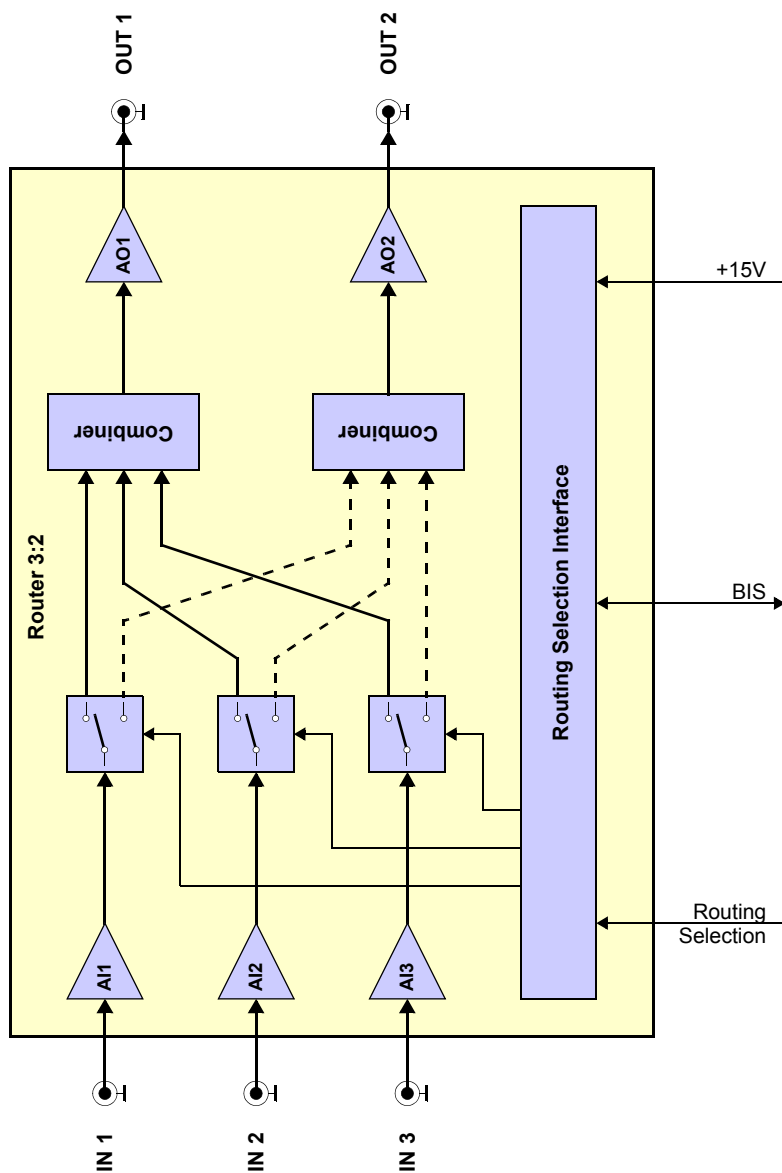

Figure 5.2. Embedded Router Block Diagram



The BLAXH300/100 E amplifier (P/N: W1345083) consists of a 3 inputs embedded router and two Class AB power amplifiers.

A nominal input power level of +4dBm produces a nominal output peak power of :

- 300W for 10% duty cycle at 100ms pulse width maximum on the X channel output.
- 140W for 25% duty cycle at 100ms pulse width maximum on the H channel output.

The unit is also capable of longer pulses for lower average power up to 30W CW on the X channel and 35W on the H channel.

#### **Embedded Router**

The embedded Router consists of a Class A RF amplifier IC's and RF switches, manufactured on a Gallium Arsenide process.

It is built on a five independent cells architecture with three RF input cells and two RF output cells. The RF input cell ensures function of amplification and routing, the RF output cell ensures the function of combining, RF amplitude thermo-stability and amplification.

The three RF inputs could be routed alone or combined to the first or the second RF output by selecting the wished RF path through the BLA controller board. The same RF input cannot be routed at the same time towards the two RF outputs.

Each entire RF path has a nominal 15dB of gain and operates at +15V DC.

Also, the router is equipped with a EEPROM for BIS information.

#### **RF Power amplifier Channel X300**

In the first section of this power amplifier, the RF input signal crosses the RF detection path. Then it is conveyed via an AsGa RF Switch to a thermo compensated attenuator (Thermal pad) and two class A drivers to build a nominal 25dB to 29dB gain block.

In this section, only the RF switch requires a control board conditioned gating signal to control the operation of the switching element.

The second section of the PA includes two FET transistors.

The circuitry around the transistors consists of complementary input and output transformers and baluns and operates the devices in push-pull.

This section requires a control board conditioned gating signal in order to control the bias gate voltage on the gates of the FETs.

The input-output gain of this section is at nominal 13dB.

The RF power amplifier has a 38dB nominal gain and operates at +32VDC. With the embedded router gain, the entire RF path has a 53dB nominal gain.

### ***RF Power Amplifier Channel H100***

In the first section of this power amplifier, the RF input signal crosses the RF detection path. Then it is conveyed to a thermo compensated attenuator (Thermal pad), a RF switch and two class A drivers to build a nominal 26dB gain block.

In this section, the RF switch and the second class A transistor requires a control board conditioned gating signal to improve better anti-droop behavior.

The second section of the PA includes one FET transistor.

The circuitry around the transistor consists of complementary input and output transformers and baluns and operates the devices in push-pull.

This section requires a control board conditioned gating signal in order to control the bias gate voltage on the gates of the FET.

The input-output gain of this section is at nominal 10dB.

The RF power amplifier has a 36dB nominal gain and operates at +32VDC. With the embedded router gain, the entire RF path has a 51dB nominal gain.

### ***RF Coupler H and X***

The bi-directional high dynamic couplers on the front panel provide an approximate 1V peak DC signal for full output power and also a peak DC signal for reflected power on channel H and X.

Both signals, forward and reflected, are analyzed by the BLA Control board for monitoring and protection setting.

---

## ***BLA Control Board***

## ***5.2.2***

The BLA Control Board has 3 functions:

- Monitor the output characteristics of the amplifier. This is done thanks to the DC peak detections of the bi-directional high dynamic couplers.
- Condition the input blanking (BLNK) signal. The board delivers it to the above mentioned RF Paths.
- Allow Ethernet communication with the workstation.

The monitoring circuitry is also useful to process the detection information and protect the amplifier from overstress in peak power, average power versus duty cycle and pulse width, so as excess of reflected power.

The control board also monitors the RF Path heatsink temperature to protect against thermal overstress.

Information from supplies and fan status board are also analyzed by the control board.

If one of the above overstresses, faults on power supplies or fans appears, the gating signal is disabled, and the status led board on the front panel displays the fault.

---

## ***BLA Extension Board***

## ***5.2.3***

This board gives the information to the control board of RF detection.

## Technical description

### **Status Led Board**

5.2.4

The Status Led Board, on the front panel of the amplifier, displays overstress functions, supplies status, and so on, as described in "**Indicators**" on page 13 and "**BLA Control Board**".

### **BIS Board**

5.2.5

The universal BIS board is located on the amplifier case and contains identifications of the amplifier.



*Technical help : please contact your local representative.*

# *Servicing the BLA*

# 6

Diagnosis and servicing access to the BLA amplifier relies on HTTP, allowing service access with any web browser.

## ***Accessing the BLA amplifier***

## **6.1**

The BLAXH300/100 E Amplifier 200-600MHz is accessible via the BLA control board with its IP address.

The IP address is given during "cf" by using TOPSPIN 2.xx software on the workstation.

In case of problems :

- Check the RJ45 cabling between amplifier, Ethernet switch and workstation.
- Check the Ethernet switch power.
- Check if the green LED on the amplifier RJ45 connector lights up.
- Check the front panel of the amplifier, LED's indicators +32V, +15V, -15V and +3.3V ON must be lit.

To access the BLAXH300/100 E Amplifier 200-600MHz, type "ha" in TOPSPIN 2.xx and choose the BLA that should be accessed or start your favourite web browser and type the given IP address as URL.

You should get the following start screen.

# Servicing the BLA

Figure 6.1. Device Information

**BRUKER** BLA Service Web

**Bruker Linear Amplifier**  
Device Information

**Amplifier Information**

- Amplifier status
- Amplifier limitations
- Routing information
- Self test & Software reset
- BIS content
- Firmware update

**Device Information**

Name: BLAXH300/100 E 200-600MHZ  
 Part number: W1345083  
 Serial number: 0020  
 Ecl: 1  
 Manufacturing location: BFR  
 Manufacturing date: 10/17/06  
 BIS type: BLA

**Software versions**

Boot version: 20051018  
 Kernel version: Windows CE 5.0  
 Application version: 20060727

**Channel Information**

Ch.	Type	Nom. power	Min freq.	Max freq.	Limits				Output num.	Input num.
					Duty cycle	Pulse width	Mismatch	Forw. peak		
1	H	100 W	180 MHz	600 MHz	25 %	100 ms	50 W (50 %)	200 W (200 %)	1	Via router
2	X	300 W	6 MHz	365 MHz	10 %	100 ms	150 W (50 %)	600 W (200 %)	2	Via router

© 2005 Bruker Biospin SA. All rights reserved.

The left panel is the navigation menu. It can be used to navigate through the service pages.



Amplifier status

6.1.1

Leads you to a page giving information about the current status from the both channels of the amplifier.

Figure 6.2. Amplifier status

**BRUKER** BLA Service Web

**Bruker Linear Amplifier**  
Amplifier status

Name:	BLAXH300/100 E 200-600MHZ	
Part number:	W1345083	
Serial number:	0020	
Ecl:	1	

	Channel 1	Channel 2
Type :	H	X
Nominal power :	100 W	300 W
Forward peak power :	0.00 %	0.00 %
Forward average power :	0.00 %	0.00 %
Reflected power :	0 %	0 %
Overdrive :	OK	OK
Pulse width :	OK	OK
Duty cycle :	OK	OK
Mismatch :	OK	OK
General gating fault :	OK	OK
Supply :	OK	OK
Thermal :	OK	OK
Blanking signal state :	inactive	inactive
Input power :	none	none
Output power :	none	none
High resolution state :	inactive	inactive
Switchbox position :	0xFF	0xFF

This page is automatically refreshed every 10 seconds

© 2005 Bruker Biospin SA. All rights reserved.

Leads you to a page giving several, default and current limits, from the both channels of the amplifier.

Figure 6.3. Amplifier limitations

The screenshot shows the 'Bruker Linear Amplifier Amplifier limitations' page. It includes a sidebar with navigation options like 'Amplifier information', 'Amplifier status', 'Amplifier limitations', 'Routing information', 'Self test & Software reset', 'BIS content', and 'Firmware update'. The main content area displays the amplifier's name and part number, followed by a table of channel information for two channels (Channel 1 and Channel 2). Each channel table lists parameters such as Type, Nom. power, Min freq., Max freq., Duty cycle, Pulse width, Mismatch, Forw. peak, Output num., and Input num., along with current limits and a 'Change limits' link.

**Amplifier information**  
**Amplifier status**  
**Amplifier limitations**  
 Routing information  
 Self test & Software reset  
 BIS content  
 Firmware update

**Bruker Linear Amplifier**  
 Amplifier limitations

Name: BLAXH300/100 E 200-600MHZ  
 Part number: W1345083  
 Serial number: 0020  
 Ecl: 1

**Channel Information**

Channel 1				Limits				Output num.	Input num.
Type	Nom. power	Min freq.	Max freq.	Duty cycle	Pulse width	Mismatch	Forw. peak		
H	100 W	180 MHz	600 MHz	25 %	100 ms	50 W (50 %)	200 W (200 %)	1	Via router
Current limits :				25 %	100 ms	50 W	200 W	<b>Change limits</b>	

Channel 2				Limits				Output num.	Input num.
Type	Nom. power	Min freq.	Max freq.	Duty cycle	Pulse width	Mismatch	Forw. peak		
X	300 W	6 MHz	365 MHz	10 %	100 ms	150 W (50 %)	600 W (200 %)	2	Via router
Current limits :				10 %	100 ms	150 W	600 W	<b>Change limits</b>	

© 2005 Bruker Biospin SA. All rights reserved.

If you want, for any reasons, to change the current limits from one or both channels of the amplifier, press **Change limits**.

Figure 6.4. Change limits

**BRUKER BLA Service Web**

**Bruker Linear Amplifier**  
Channel limitations

Amplifier information  
Amplifier status  
**Amplifier limitations**  
Routing information  
Self test & Software reset  
BIS content  
Firmware update

Name: BLAXH300/100 E 200-600MHZ  
Part number: W1345083  
Serial number: 0020  
Ecl: 1

**Channel 1 limitations**

**Warning : Changing these settings will overwrite the limitations defined with the spectrometer software. Please use this page for test purposes only.**

Type :	H			
Nominal power :	100 W			
Min. frequency :	180 MHz			
Max. frequency :	600 MHz			
	Default	Current	New	Maximum
Duty cycle limit :	25 %	25 %	<input type="text" value="25"/> %	25 %
Pulse width limit :	100 ms	100 ms	<input type="text" value="100"/> ms	100 ms
Mismatch limit :	50 W (50 %)	50 W	<input type="text" value="50"/> W	100 W
Forward peak limit :	200 W (200 %)	200 W	<input type="text" value="200"/> W	200 W
			<input type="button" value="Apply"/>	
Output number :	1			
Input number :	Via router			

© 2005 Bruker Biospin SA. All rights reserved.

**BRUKER BLA Service Web**

**Bruker Linear Amplifier**  
Channel limitations

Amplifier information  
Amplifier status  
**Amplifier limitations**  
Routing information  
Self test & Software reset  
BIS content  
Firmware update

Name: BLAXH300/100 E 200-600MHZ  
Part number: W1345083  
Serial number: 0020  
Ecl: 1

**Channel 2 limitations**

**Warning : Changing these settings will overwrite the limitations defined with the spectrometer software. Please use this page for test purposes only.**

Type :	X			
Nominal power :	300 W			
Min. frequency :	6 MHz			
Max. frequency :	365 MHz			
	Default	Current	New	Maximum
Duty cycle limit :	10 %	10 %	<input type="text" value="10"/> %	10 %
Pulse width limit :	100 ms	100 ms	<input type="text" value="100"/> ms	100 ms
Mismatch limit :	150 W (50 %)	150 W	<input type="text" value="150"/> W	300 W
Forward peak limit :	600 W (200 %)	600 W	<input type="text" value="600"/> W	600 W
			<input type="button" value="Apply"/>	
Output number :	2			
Input number :	Via router			

© 2005 Bruker Biospin SA. All rights reserved.

Read the warnings, change limit parameters and press **Apply** if you are sure of that.

Leads you to a page giving information about the current routed RF path at the amplifier inputs.

Default RF path is INPUT1 to CHANNEL1 and INPUT2 to CHANNEL2.

Figure 6.5. Routing information

The screenshot shows the Bruker BLA Service Web interface. The main content area is titled "Bruker Linear Amplifier Routing Information & Setting". It displays the following information:

- Name: BLAXH300/100 E 200-600MHZ
- Part number: W1345083
- Serial number: 0020
- Ecl: 1

A warning message is displayed: "Warning : Changing these settings will overwrite the routes defined with the spectrometer software. Please use this page for test purposes only."

Below the warning is a table for configuring routing:

Input number	Current channel	Possible channels	New route
1	1	1, 2	Channel 1 <input type="button" value="set new route"/>
2	2	1, 2	Channel 2 <input type="button" value="set new route"/>
3	0	1, 2	no route <input type="button" value="set new route"/>

© 2005 Bruker Biospin SA. All rights reserved.

Read the warnings, it is allowed to change routing configuration (ex: new route INPUT2 to CHANNEL1 and INPUT3 to CHANNEL2), press **Set new route** if you are sure of that.

Leads you to a page allowing you to do a self-test on the BLA Control board (Hardware test) and to do a software reset.

Both operations can be done if the amplifier doesn't work correctly.

Figure 6.6. Self-test and report

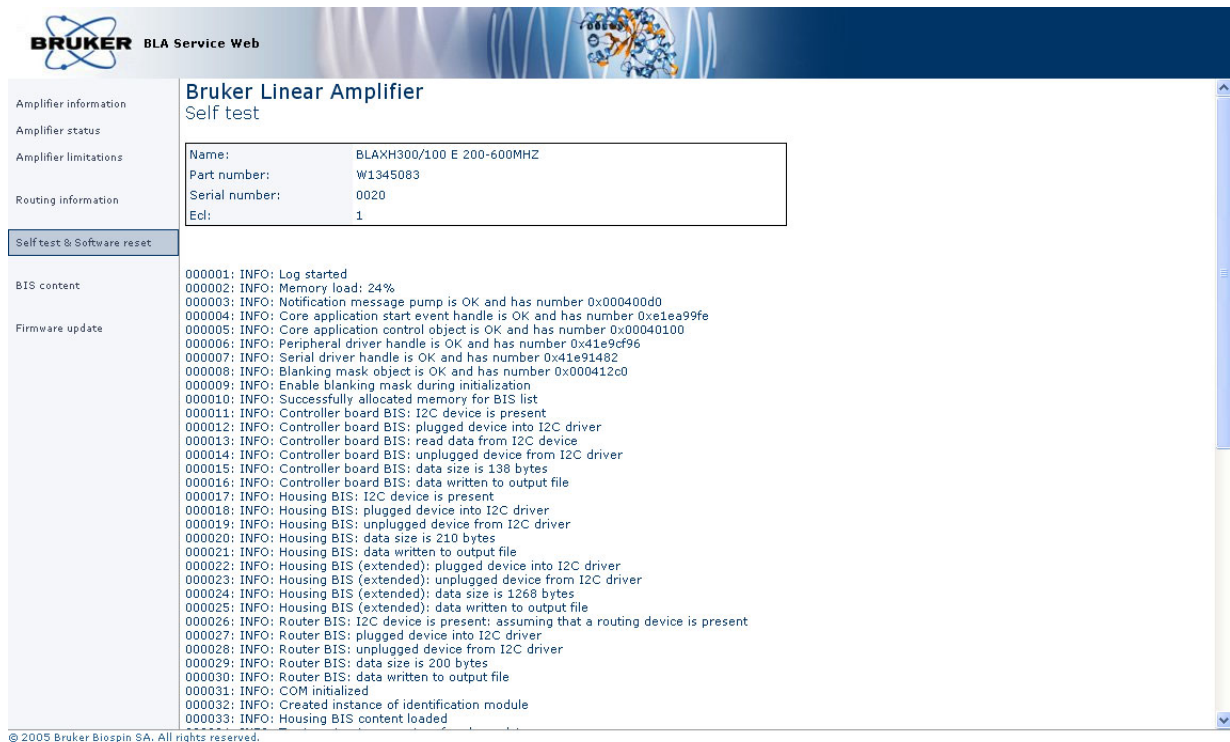
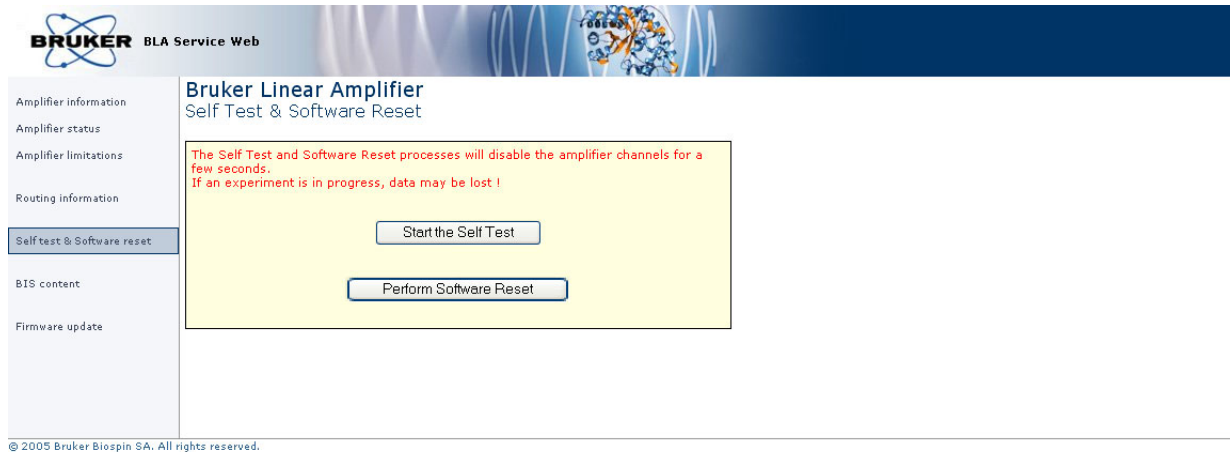

Read the warnings, press **Start the self-test**.

You should have only blue lines in the report.

# Servicing the BLA

Figure 6.7. Perform software reset and report

The screenshot shows the 'Bruker Linear Amplifier Self Test & Software Reset' page. On the left is a navigation menu with options: Amplifier information, Amplifier status, Amplifier limitations, Routing information, Self test & Software reset (highlighted), BIS content, and Firmware update. The main content area has a yellow background with a red warning box: 'The Self Test and Software Reset processes will disable the amplifier channels for a few seconds. If an experiment is in progress, data may be lost !'. Below the warning are two buttons: 'Start the Self Test' and 'Perform Software Reset'. The footer contains the copyright notice: '© 2005 Bruker Biospin SA. All rights reserved.'

The screenshot shows the 'Bruker Linear Amplifier Software Reset' page. The navigation menu is the same as in the previous screenshot. The main content area displays a table with device information:

Name:	BLAXH300/100 E 200-600MHZ
Part number:	W1345083
Serial number:	0020
Ecd:	1

Below the table, the text reads: 'Software Reset in progress. The device will now restart.' The footer contains the copyright notice: '© 2005 Bruker Biospin SA. All rights reserved.'

Read the warnings, press **Perform software reset**.  
You should have the following screen.

Leads you to a page giving information about the current BIS programmed on the amplifier.

Figure 6.8. BIS content

The screenshot shows the Bruker BLA Service Web interface. The main heading is "Bruker Linear Amplifier BIS Content". On the left, there is a navigation menu with options: Amplifier information, Amplifier status, Amplifier limitations, Routing information, Self test & Software reset, BIS content (highlighted), and Firmware update. The main content area displays three BIS entries:

BIS Id:	Description
1	BLA Controller
2	BLA Housing
3	Mini-Router

Each entry includes detailed BIS content with fields for description, type, and content. The content is formatted as key-value pairs, such as \$Bis,1,20060210,2048,BLAC,1# and \$Prd,W1522040,0262,1,BFR,20061009#.

© 2005 Bruker Biospin SA. All rights reserved.

Leads you to a page allowing you to download new firmware.

Figure 6.9. Firmware update

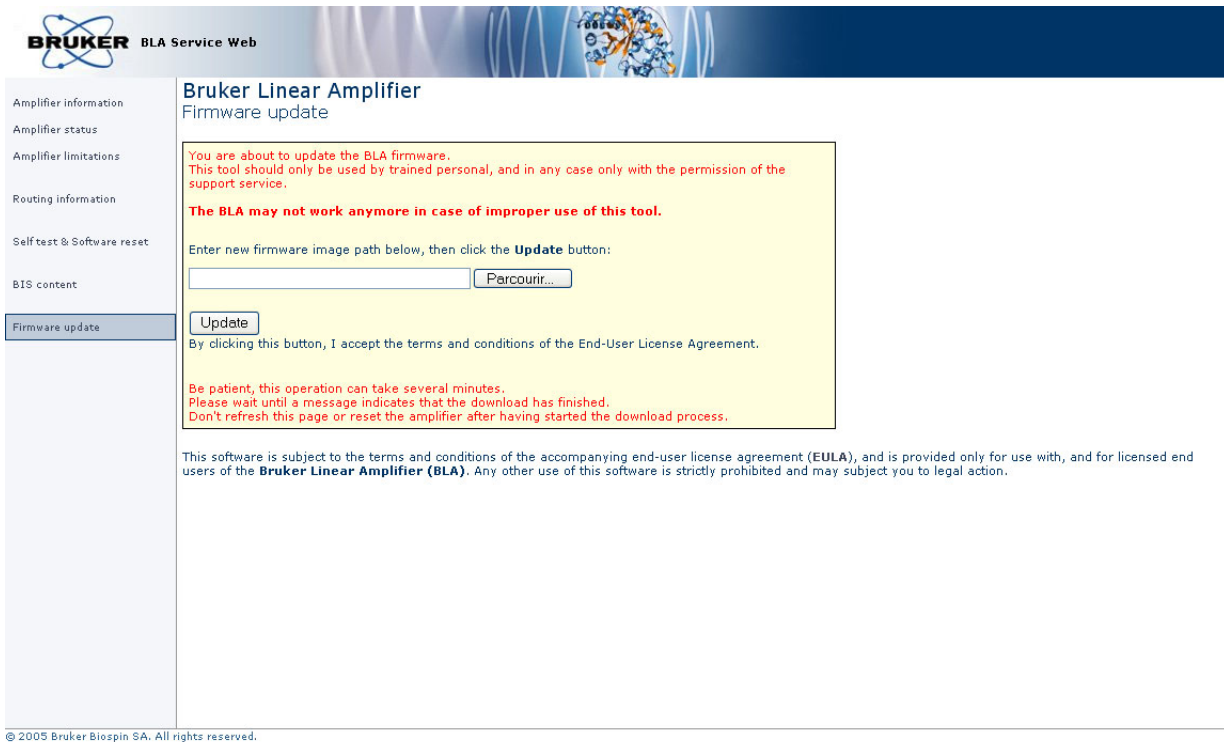

Read the warnings, press the Browse button for selecting the new firmware file to download and press **Update**. Download the new firmware will take a few minutes.



*NOTE : This button caption depends on your operating system language settings*



# Specifications

# 7

## General specifications

## 7.1

Table 7.1. BLAXH300/100 E Common Specifications

<b>Constant Internal Protection</b>	Supplies & Fans faults & Over temperature Forward Power for X and H channels: Peak & CW Power Pulse Width Duty Cycle Reflected Power : Peak & CW Power
<b>Front Panel Indicators</b>	Amplifier Status Led Board
<b>Front Panel Interfaces</b>	1 x I/O 8 pins RJ45 connector, 1 x 7 pins female connector for QNP Accessory
<b>Front Panel controls</b>	AC Line ON / OFF
<b>Front Panel connectors</b>	3 x RF input, 2 x RF output, 2 x blanking input
<b>Rear Panel Interface</b>	AC Line in socket
<b>Cooling System</b>	Forced air cooling (from front to rear)
<b>Size</b>	19" rack cabinet x 3U height x 520mm depth
<b>Weight</b>	19kg
<b>Power requirements</b>	220-230VAC $\pm$ 15%, single phase 50-60Hz Bruker part number W1304005 Power consumption max. 0.74kVA

## Specifications

Table 7.2. BLAXH300/100 E channel X300 specifications

<b>Frequency range</b>	6 to 365MHz
<b>Linear Gain</b>	53dB $\pm$ 1dB typical
<b>Gain Flatness</b>	$\pm$ 1dB max.
<b>Minimum Pulsed Output Power</b> (@ nominal input +4dBm)	300W min. full range
<b>CW Output Power</b> (internal limitation)	30W max.
<b>Linear Output Power</b>	300W typical @ 1dB compression
<b>Linearity</b>	$\pm$ 1dB to 300W typical
<b>Amplifier biasing</b>	Class AB Operation
<b>Blanking Delay Time</b>	1 $\mu$ s min.
<b>RF Rise Time</b>	< 100ns
<b>RF Fall Time</b>	< 50ns
<b>DC Ringing</b>	$\pm$ 500mV typical (due to blanking signal)
<b>Input Noise Figure</b>	9dB typical
<b>Output Noise Power</b> (Unblanked)	-112dBm @ 1Hz
<b>Output Noise Power</b> (Blanked)	< 25dB over Thermal noise
<b>IN / OUT Impedance</b>	50 $\Omega$
<b>Input V.S.W.R. Route OFF</b>	1.2 max.
<b>Input V.S.W.R. Route On</b>	1.3 max. (100 to 365MHz) (up to 1.9 max. @ 20MHz)
<b>Output Harmonics</b> (2fc ; 3fc)	-30dBc ; -10dBc max. @ 300W
<b>Pulse Width</b> (internal limitation)	100ms @ 300W (up to CW @ 30W)
<b>Duty Cycle</b> (internal limitation)	10% @ 300W (up to 100% @ 30W)
<b>Droop &amp; Pulse Flatness</b>	$\pm$ 4% @ 300W for 20ms Pulse Width $\pm$ 1.5% @ 300W for 1ms Pulse Width
<b>Amplitude stability versus temperature</b>	$\pm$ 0.1% / $^{\circ}$ C max.

Table 7.3. BLAXH300/100 E channel H100 specifications

<b>Frequency range</b>	180 to 600MHz
<b>Linear Gain</b>	51dB $\pm$ 1dB typical
<b>Gain Flatness</b>	$\pm$ 1dB max.
<b>Minimum Pulsed Output Power</b> (@ nominal input +4dBm)	140W min. from 220 to 564MHz 100W min. from 180 to 220MHz and @ 600MHz
<b>CW Output Power</b> (internal limitation)	35W max.
<b>Linear Output Power</b>	80W typical @ 1dB compression
<b>Linearity</b>	$\pm$ 1dB to 80W typical
<b>Amplifier biasing</b>	Class AB Operation
<b>Blanking Delay Time</b>	1 $\mu$ s min.
<b>RF Rise Time</b>	< 100ns
<b>RF Fall Time</b>	< 50ns
<b>DC Ringing</b>	$\pm$ 200mV typical (due to blanking signal)
<b>Input Noise Figure</b>	8dB typical
<b>Output Noise Power</b> (Unblanked)	-115dBm @ 1Hz
<b>Output Noise Power</b> (Blanked)	Thermal noise
<b>IN / OUT Impedance</b>	50 $\Omega$
<b>Input V.S.W.R. Route OFF</b>	1.2 max.
<b>Input V.S.W.R. Route On</b>	1.3 max.
<b>Output Harmonics</b> (2fc ; 3fc)	-40dBc ; -16dBc max. @ 100W
<b>Pulse Width</b> (internal limitation)	100ms @ 140W (up to CW @ 35W)
<b>Duty Cycle</b> (internal limitation)	25% @ 140W (up to 100% @ 35W)
<b>Droop &amp; Pulse Flatness</b>	$\pm$ 2% @ 140W for 20ms Pulse Width
<b>Amplitude stability versus temperature</b>	$\pm$ 0.15% / $^{\circ}$ C max.



# Service Information and Maintenance

# 8

Every intervention on the device must be carried out by a authorized and qualified person. Any failure due to a non-respect of the following instructions will not be attributable to BRUKER and will not be covered by the guarantee clauses.

## **Preventive maintenance of the RF module on BLA-type Amplifiers** **8.1**

---

The RF module inside BLA's Amplifiers is equipped with a easily extractible PUSH FAN Assembly.

Fan's on assembly have a high reliability and manufacturer gives a expected live time of 70000 hours (8 years) at 25°C and 5 years at 60°C.

Replacement of the assembly could be done in the field when a misfonction of fans is detected by lightning from the OVERHEAT Status Led.

To prevent such a misfonction, a preventive maintenance could be done every 4 years.

This assembly can be ordered on the manufactory BBIO-FR by P/N:

- **W1346523** «PUSH FAN ASSEMBLY 6».

### **Operation**

### **8.1.1**

---



*Read below or see SIH0292.*

---

1. Disconnect all cables from the front panel and the supply connector on the rear panel. Remove the amplifier from the NMR console and place it on a secure flat surface.
2. Unscrew and remove the coverage plate from the amplifier.
3. Disconnect the 2 wires (red +32V / black GND) from the RF module dispatch supply connectors and disconnect the fan status wires (white) from BLA Control board connector J18.

Figure 8.1. Push Fan Assembly

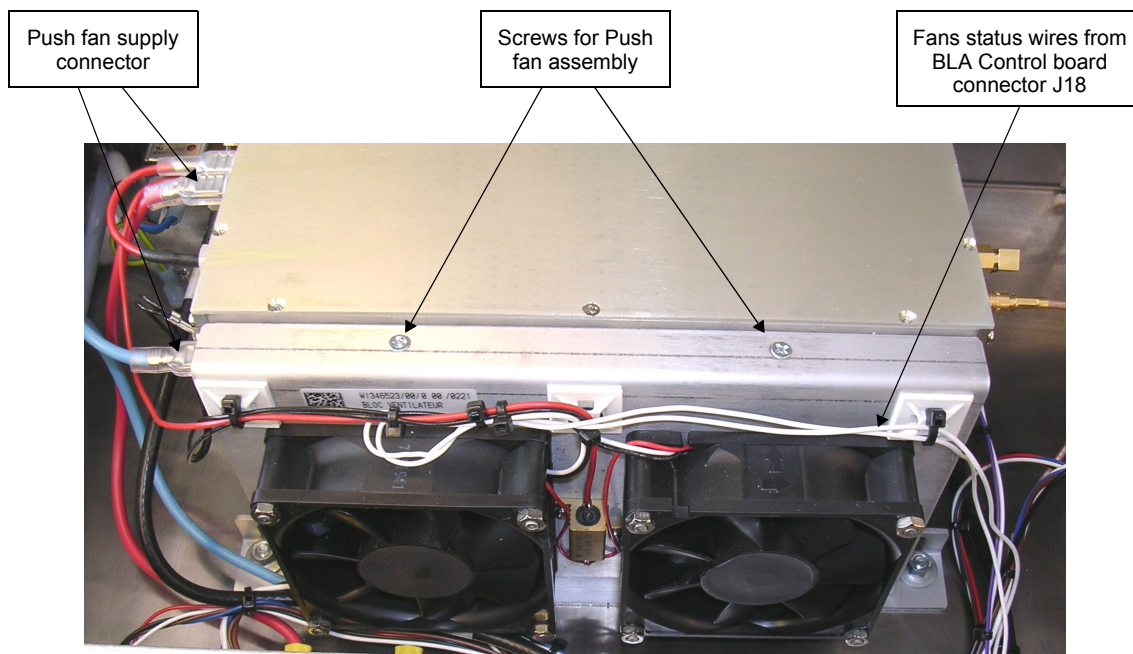

4. Unscrew the 2 screws from the top of the push fan assembly.
5. Remove the push fan assembly.
6. Place correctly the new fan assembly in the bottom holes from the RF module and screw it.
7. Connect all wires (status and supply).
8. Connect line cord and turn on the BLA amplifier. Note that the fans are turning and no OVERHEAT status led appears on front panel.
9. Put the coverage plate on the BLA amplifier and screw it.
10. Put the amplifier in the NMR console, connect all cables on the front panel and the line cord on the rear panel.

# Figures

<b>1</b>	<b>General Infomation</b>	<b>5</b>
<b>2</b>	<b>Safety</b>	<b>7</b>
Figure 2.1.	Identifying plate .....	7
Figure 2.2.	Manufacturer's nameplate .....	8
Figure 2.3.	General hazard symbol .....	9
<b>3</b>	<b>Installation</b>	<b>11</b>
<b>4</b>	<b>Operation</b>	<b>13</b>
Figure 4.1.	BLAXH300/100 E Front Panel Design .....	15
Figure 4.2.	BLAXH300/100 E Front Panel View .....	15
Figure 4.3.	BLAXH300/100 E Rear Panel View .....	16
<b>5</b>	<b>Technical description</b>	<b>17</b>
Figure 5.1.	BLAXH300/100 E System Block Diagram .....	18
Figure 5.2.	Embedded Router Block Diagram .....	19
<b>6</b>	<b>Servicing the BLA</b>	<b>23</b>
Figure 6.1.	Device Information .....	24
Figure 6.2.	Amplifier status .....	25
Figure 6.3.	Amplifier limitations .....	26
Figure 6.4.	Change limits .....	27
Figure 6.5.	Routing information .....	28
Figure 6.6.	Self-test and report .....	29
Figure 6.7.	Perform software reset and report .....	30
Figure 6.8.	BIS content .....	31
Figure 6.9.	Firmware update .....	32
<b>7</b>	<b>Specifications</b>	<b>33</b>
<b>8</b>	<b>Service information and maintenance</b>	<b>37</b>
Figure 8.1.	Push Fan Assembly .....	38





# Tables

<b>1</b>	<b>General Information</b>	<b>5</b>
<b>2</b>	<b>Safety</b>	<b>7</b>
<b>3</b>	<b>Installation</b>	<b>11</b>
<b>4</b>	<b>Operation</b>	<b>13</b>
Table 4.1.	Indicators assignment .....	13
Table 4.2.	Coaxial Connectors assignment .....	14
Table 4.3.	RJ45 Pin assignment .....	14
<b>5</b>	<b>Technical description</b>	<b>17</b>
<b>6</b>	<b>Servicing the BLA</b>	<b>23</b>
<b>7</b>	<b>Specifications</b>	<b>33</b>
Table 7.1.	BLAXH300/100 E Common Specifications .....	33
Table 7.2.	BLAXH300/100 E channel X300 specifications .....	34
Table 7.3.	BLAXH300/100 E channel H100 specifications .....	35
<b>8</b>	<b>Service information and maintenance</b>	<b>37</b>





---

# **Bruker BioSpin** **your solution partner**

Bruker BioSpin provides a world class, market-leading range of analysis solutions for your life and materials science needs

---

● **Bruker BioSpin Group**

[info@bruker-biospin.com](mailto:info@bruker-biospin.com)  
[www.bruker-biospin.com](http://www.bruker-biospin.com)