

BSMS/2

**PNK Pneumatic Module
Technical Manual**

Version 001

BRUKER

The information in this manual may be altered without notice. BRUKER accepts no responsibility for actions taken as a result of use of this manual. BRUKER accepts no liability for any mistakes contained in the manual, leading to coincidental damage, whether during installation or operation of the instrument. Unauthorised reproduction of manual contents, without written permission from the publishers, or translation into another language, either in full or in part, is forbidden.

This manual was written by
Michael Schenkel
© February 6, 2002: Bruker AG
Fällanden, Switzerland

P/N: Z31635
DWG-Nr: 1346001

Contents

	Contents	3
1	BSMS/2 PNK Modules	5
1.1	Introduction	5
1.2	Basic Functionality	5
1.3	General Installation Hints	5
1.4	Module Drawings	6
1.5	PNK3S Description	9
	Emergency Lift Functional Description	9
	PNK3S additional Installation Hints	10

BSMS/2 PNK Modules

1

Introduction

1.1

In the BSMS/2, all pneumatic systems and associated driver electronics have been integrated in one module, called PNK.

This module is located on the rear side in the rightmost slot (as seen from rear) and comes in three variants:

PNK/3, Z003139

This is the standard module with one spin valve and two lift valves.

PNK/5, Z003140

This is the “wide bore” module with two spin valves and three lift valves, accounting for the increased air consumption.

PNK/3S, Z003828

This is a standard version with an additional emergency lift feature, intended for the Cryo Probe Sample Safety option.

Basic Functionality

1.2

The PNK is controlled by the BSMS/2 SLCB by two PWM (Pulse Width Modulation) signals. These signals are galvanically isolated and then fed to two groups of switching drivers. There is one driver per valve solenoid.

All valves in one group (1,2 or 3 valves, depending on group and PNK type) are connected in parallel.

A screwdriver operated needle valve at the spin output greatly improves the PWM linearity by presenting a flow dependant exhaust pressure to the PWM valve. Furthermore, the needle valve adapts the PWM range to the spin airflow range when calibrated properly.

General Installation Hints

1.3

See Z31187 “BSMS Sample and Level Manual” (SLCB) for a detailed description of spin and lift calibration. Lift calibration usually is not critical and for spin calibration there is a function in BSMS tool that guides you through the different steps.

Figure 1.1. PNK3 Drawing

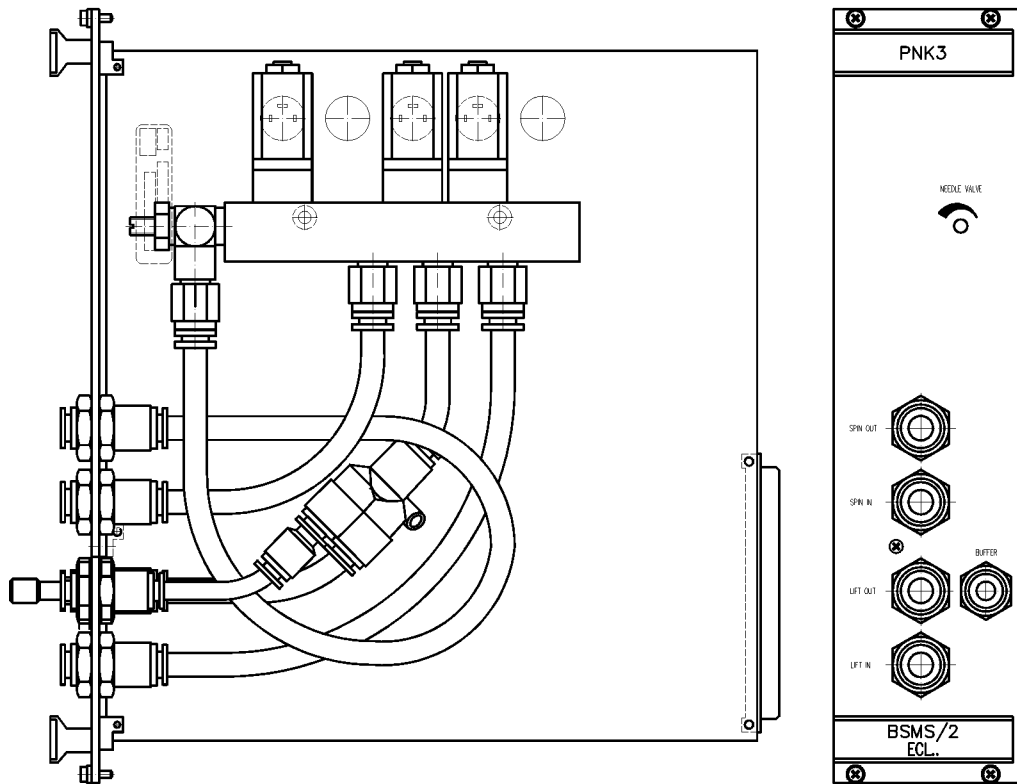

Note the valve block carrying three valves only.

Figure 1.2. PNK5 Drawing

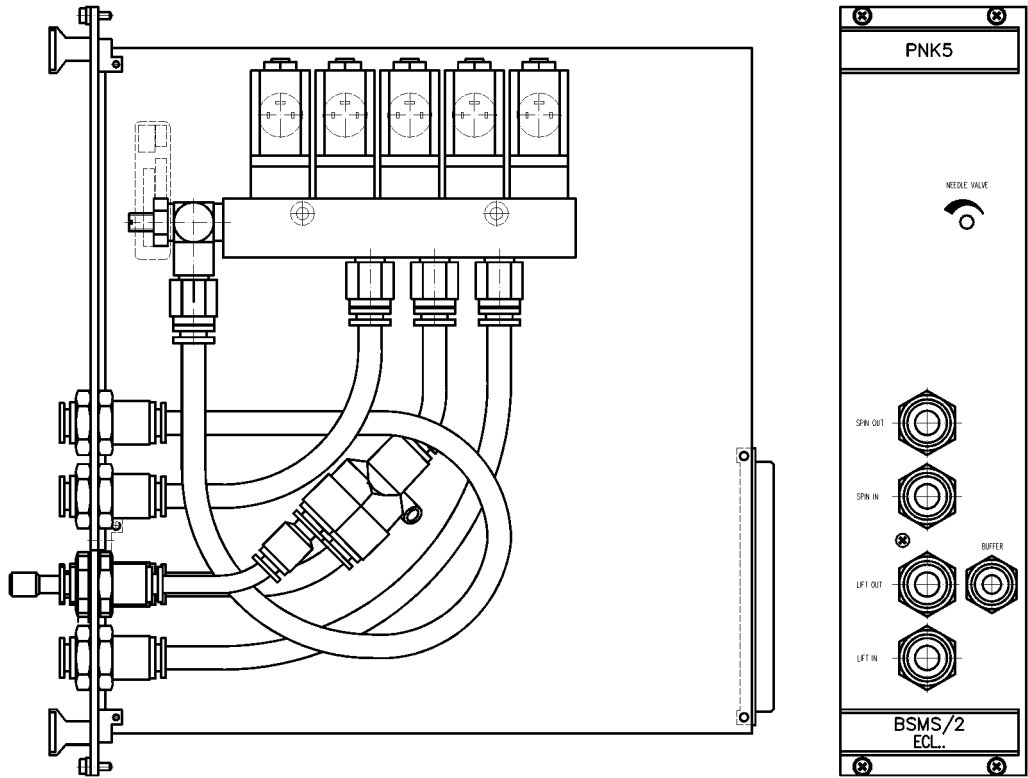

Note the valve block carrying five valves.

Figure 1.3. PNK3S Drawing

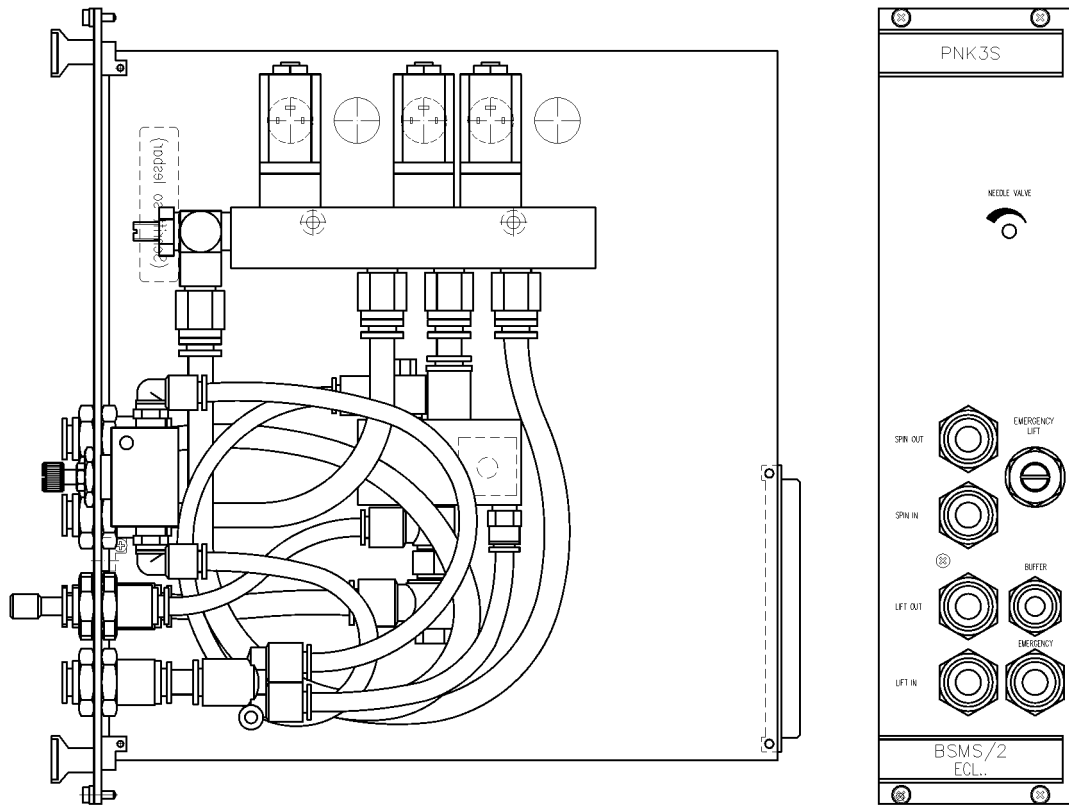

Note the manual valve (marked "EMERGENCY LIFT") and the emergency lift inlet (marked "EMERGENCY").

Figure 1.4. Block Diagram Emergency Lift

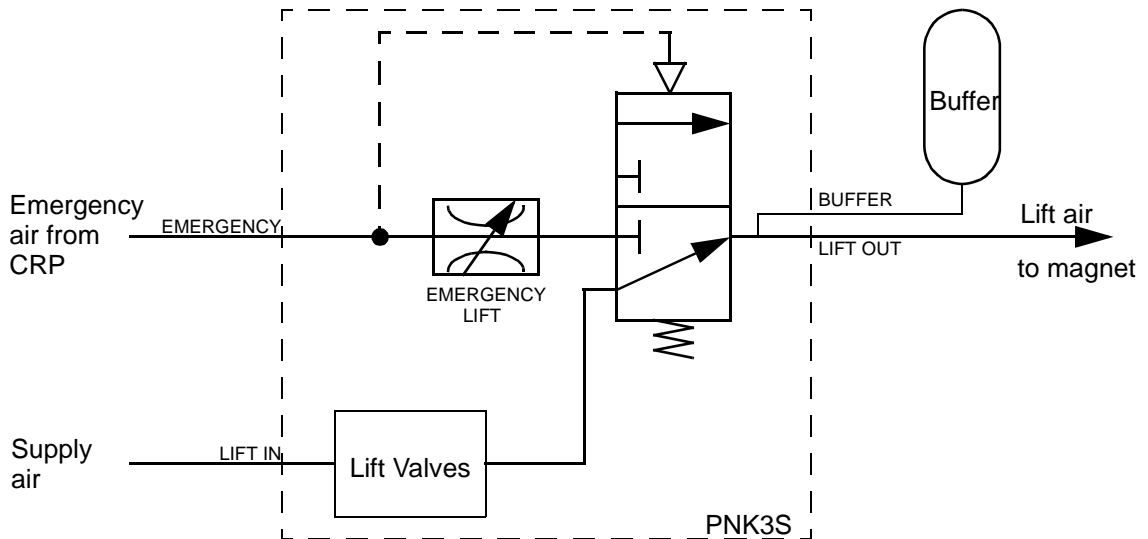

During normal operation, the lift air from the lift valves is passed through to the lift air outlet and the buffer. The pneumatic switchover valve is held in this position by a spring.

In case of an emergency sample eject, the CRP delivers lift air to the inlet marked "EMERGENCY". This air is throttled by the EMERGENCY LIFT valve, allowing the valve operating pressure to build up and finally switch over the valve.

Now the emergency lift air is passed through to the lift air outlet and the buffer. The normal lift air is held off and the sample protected from jumping out of the magnet because of double lift air.

That same throttle valve is used to adjust the emergency lift airflow to a value that comfortably suspends the sample in its up position without catapulting it out of the magnet.

The buffer smooths the instantaneous switchover and eventual switchback and sample landing.

! **WARNING:**
The standard buffer must be present and working. A missing or plugged buffer can result in sample and/or probehead damage due to the instantaneous switching of the emergency lift.

In contrast, the normal lift is slowly ramped up and down and a missing buffer would only be remarked in case of a power failure during a "lift up" period.

When exchanging an existing PNK3 with a new PNK3S, the spin and lift must be recalibrated (as with any PNK exchange) and the emergency lift airflow must be adjusted.

1. replace the old PNK3 with the new PNK3S
2. check the buffer connection
3. start bsms tool, go to SLCB > Spin Calibration
4. follow the instructions
5. close the EMERGENCY LIFT valve (turn clockwise)
6. access the Cryo Controller (CRCO) with UniTool and switch on emergency lift
7. adjust the valve until the sample floats in the upper position
8. check adjustment by switching on and off with UniTool

The sample must not land too hard or jump too far out of the magnet. If you cannot find a satisfactory valve position, check the following:

- Is the buffer connected and not plugged?
- Are shim system and probehead mounted ok (air leakage)?
- Is the sample temperature stub unconnected and exhausting lift air?
- Is the Cryo Platform air supply pressure below specification?
- Is the emergency lift hose running from CRP to console bent or squeezed?
- Does the Cryo Platform deliver lift air? Use a short piece of hose to open the self closing hose plug at the Cryo Platform.
- Disconnect the LIFT OUT and connect an air supply to EMERGENCY lift in. The air supply must switch over the pneumatic valve and exhaust at LIFT OUT. Try to change the airflow with the manual valve.

