

# BVT3000

- Variable Temperature Unit  
Technical Manual  
Version 004

The information in this manual may be altered without notice.

BRUKER accepts no responsibility for actions taken as a result of use of this manual. BRUKER accepts no liability for any mistakes contained in the manual, leading to coincidental damage, whether during installation or operation of the instrument. Unauthorised reproduction of manual contents, without written permission from the publishers, or translation into an other language, either the entire manual or a part of it, is forbidden.

This manual describes the units as they are at the date of printing. On request, the manufacturer shall supply circuit diagrams, lists of components, descriptions, calibrating instructions and any other information for use by qualified personnel of the user, in charge of repairing the parts of the unit which have been stated by the manufacturer to be "repairable". Such supply shall in no event constitute permission to modify or repair the units or approval of the same.

All rights reserved for the units, circuits, processes and appellations mentioned herein.

This unit is not designed for any type of use which is not specifically described in this manual. Such use may be hazardous.

This manual was written by

[PODADERA Daniel](#)

© October 17, 2006: Bruker Biospin SA

Wissembourg, France

P/N: Z31348  
DWG-Nr: 1057.004

# Contents

	<b>Contents .....</b>	<b>iii</b>
<b>1</b>	<b>Description .....</b>	<b>5</b>
1.1	Introduction .....	5
1.2	BVT3000 main components .....	6
1.3	Parts location .....	7
1.4	Principle of operation .....	8
1.5	The front panel .....	8
1.6	Gas flow circuit .....	9
	Setting up the gas flow .....	9
	Flow rate rules .....	10
1.7	Front panel connectors .....	11
	NMR BVT3000 Probe heater, BCU05 and N <sub>2</sub> option connectors presentation .....	11
	EPR BVT Probe heater and N <sub>2</sub> option connectors presentation .....	11
	Connector Pin out .....	12
<b>2</b>	<b>Options .....</b>	<b>17</b>
2.1	BASM - Auxiliary sensors module .....	17
2.2	Manual Command Module - BMCM .....	18
2.3	Low temperature options .....	19
2.4	Liquid nitrogen exchanger .....	20
	Exchanger presentation .....	20
2.5	Liquid nitrogen evaporator .....	21
	Evaporator presentation .....	21
2.6	BCU05 gas cooler .....	22
<b>3</b>	<b>Configuration .....</b>	<b>23</b>
3.1	Sensor selection .....	23
3.2	Eurotherm 2416 configuration .....	23
<b>4</b>	<b>Remote interface control .....</b>	<b>25</b>
4.1	Microcontroller interface .....	25
4.2	Digital interface specifications .....	25
4.3	Commands and communication protocol .....	26
4.4	Control Characters .....	26
4.5	List of commands .....	27
4.6	RS232 link characteristics .....	27
4.7	RS232 cable .....	28
4.8	Authorised functions .....	28
	AF (Air flow) .....	29

# Contents

	CM (Check memory for test only) .....	30
	CO (Communications speed) .....	30
	DL (Download) .....	31
	DT (DAC check for test only) .....	32
	ES (Error status) .....	32
	HP (Heater power) .....	33
	IS (Interface status) .....	34
	NH (Nitrogen heater) .....	35
	NP (Nitrogen heater power) .....	35
	P1 (Port 1 for test only) .....	36
	P2 (Port 2 for test only) .....	36
	P3 (Port 3 for test only) .....	37
	P4 (Port 4 for test only) .....	38
	RB (Read BBIS) .....	39
	SV (Software version) .....	40
	WB (Write BBIS) .....	40
	WR (Write record) .....	41
	XR (Extract a record) .....	42
<b>5</b>	<b>Technical specifications .....</b>	<b>43</b>
5.1	Specifications .....	43
5.2	Security fuses .....	44
	<b>Figures .....</b>	<b>45</b>
	<b>Tables .....</b>	<b>47</b>

# Description

# 1

## Introduction

## 1.1

The variable temperature unit BVT3000 for precise sample temperature regulation is equipped with a microcontroller interface for remote control by the host computer. The BVT3000 is manufactured in a separate housing.

The unit includes:

- A main board called interface board with a microcontroller.
- A temperature controller (EUROTHERM model 2416).
- A main transformer that supplies the microcontroller and its electronics and the optoisolated power stage of the probe heater.
- The gas flow circuitry (pressure regulator and a block of four valves for gas flow control).
- An option printed circuit for liquid nitrogen heater evaporator or liquid nitrogen exchanger control.
- This temperature unit can be used with NMR spectrometers or ESR spectrometers. For EPR, the thermocouple connector is a K type.

## Description

Figure 1.1. BVT3000 block diagram

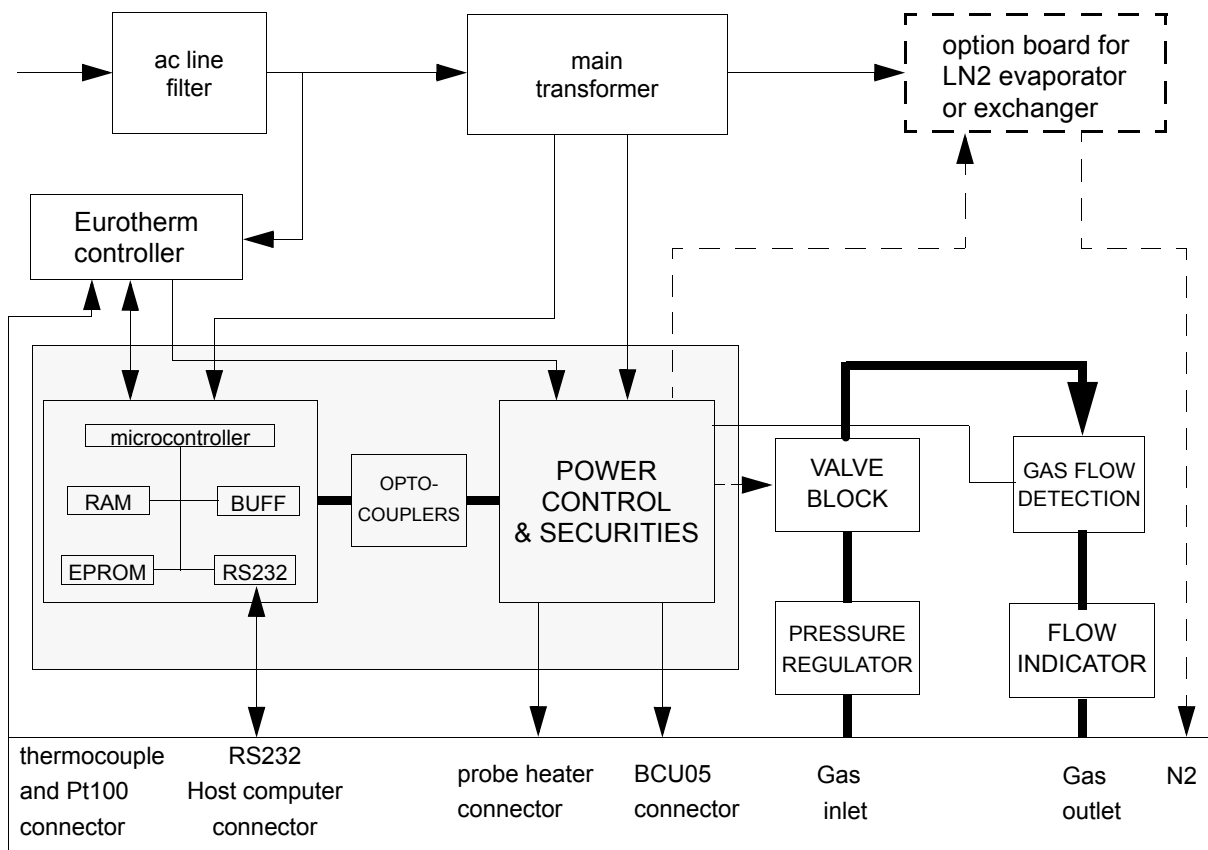

### BVT3000 main components

1.2

The interface board has a microcontroller for remote control of the BVT3000. Two RS232 links are available on this printed circuit. One link, on the front panel side, is for the communication with host computer and the other for the communication with the temperature controller.

A main toric transformer supplies the different groups. On the rear panel there is a power supply plug. The thyristor bridge, for control of heater power, is also housed in the rear panel. On the front panel a gas flow indicator (with a steel ball) detects the gas flow. A device called valve block (a system of 4 valves) determines the gas flow and is under software control.

Figure 1.2. Parts location

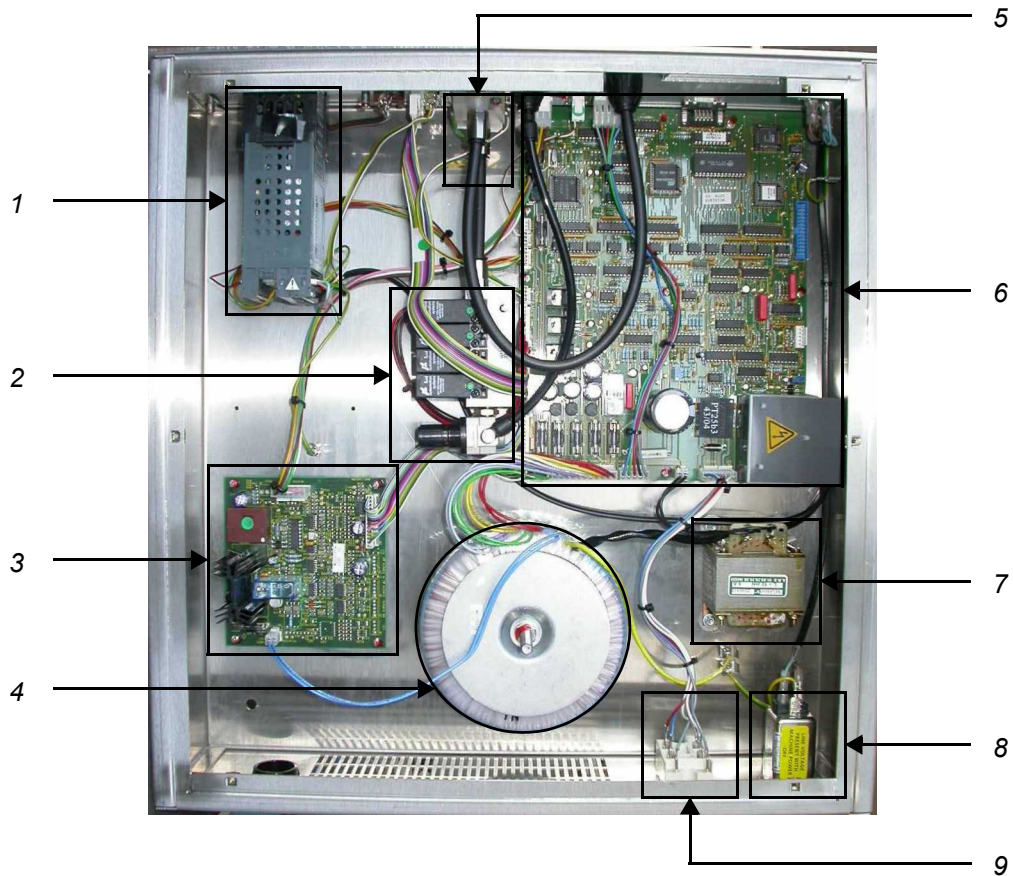

1. Eurotherm controller (2416)
2. Valve block and pressure regulator
3. Evaporater / Exchanger option board
4. Main transformer
5. Gas flow indicator
6. Main board
7. Probe heater coil
8. Power plug
9. Thyristor bridge

## Description

### *Principle of operation*

1.4

The sample is heated by a constant gas flow delivered by the BVT3000. A temperature sensor (e.g. a thermocouple) located under the sample tube measures the gas temperature. The temperature controller compares the probe temperature to the target temperature programmed by the operator, and regulates the power applied to the heater in order to stabilise the gas temperature. A special detector monitors the gas flow and switches off the heater power if the gas flow is missing. A security thermocouple checks also the heater temperature and avoids probe overheating.

### *The front panel*

1.5

On the front panel, there is:

1. Auxiliary sensors (option)
2. Gas out
3. Gas inlet
4. Pt100 or BTO2000 connector
5. Power switch
6. RS232 connector
7. Heater connector
8. BCU05 connector
9. N<sub>2</sub> connector
10. Gas flow indicator
11. BTO2000 power supply or BVTB 3500 connector
12. Thermocouple connector type (T type for NMR ; K type for EPR)
13. Eurotherm controller (2416)

*Figure 1.3. BVT3000 front panel*





## Gas flow circuit

1.6

A pressure regulator mounted on the valve block delivers gas at constant pressure to the group of valves. Each valve, when open, allows the gas to flow through a calibrated hole. As all valves are in parallel, it is possible to obtain 15 different gas flow rates.

The regulator is factory-adjusted to obtain approximately 2000 l/h when all valves are open.

The default value at «POWER ON» can be changed by hardware jumpers (JP6 to JP9) see **"Port 4 definition" on page 38** and **"Valve jumpers settings" on page 39**.

On the front panel a gas flow indicator with a steel ball indicates the actual gas flow. An optical barrier at the bottom detects a missing gas flow.

Figure 1.4. Gas flow circuit

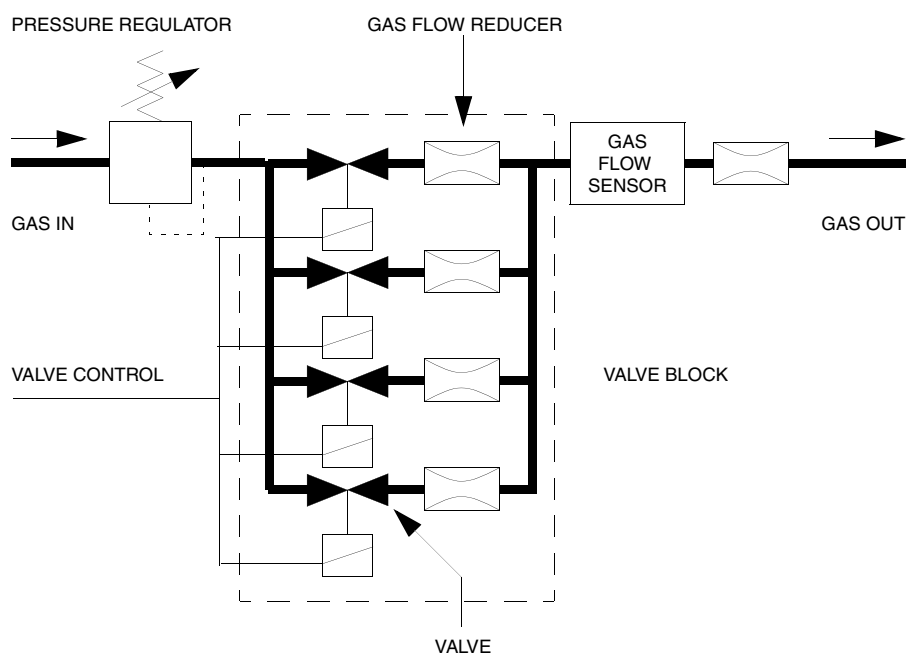

## Setting up the gas flow

1.6.1

Connect the BVT3000 gas input to a dry air or N<sub>2</sub> gas line. The input pressure should be at least 4 bar and must not exceed 8 bar. Power on the BVT3000. The default value of the flow rate is set according to the position of jumper JP6 to JP8. The gas flow rate can also be changed by software in the «EDTE» program.

Table 1.1. Flow rate versus command

Decimal combination	Combination ABCD	Flow rate (l/h)
0	0000	0
1	0001	135
2	0010	270
3	0011	400
4	0100	535
5	0101	670
6	0110	800
7	0111	935
8	1000	1070
9	1001	1200
10	1010	1335
11	1011	1470
12	1100	1600
13	1101	1735
14	1110	1870
15	1111	2000

## Flow rate rules

1.6.2



*Flow rate default value is applied whenever the heater is off.*

### Rules

- Software flow rate change is always taken in account.
- Software flow rate change is applied only when heater is switched ON.
- If an exchanger is connected, Default flow value is set to 0.

Example:

Step 1: Default value is jumper set to 3 ⇔ 400l/h

Step 2: Heater is off, flow rate is 400l/h

Step 3: Software flow rate change to 5 ⇔ 670l/h

Step 4: Heater is still off ⇔ flow rate is still 400l/h

Step 5: Heater is switched on ⇔ flow rate set to 670l/h



*When heater is on, all the flow rate changes are immediately set.*

Step 6: Heater is switched off ⇔ flow rate set to default value (400l/h)

**Front panel connectors**

**1.7**

**NMR BVT3000 Probe heater, BCU05 and N<sub>2</sub> option connectors presentation**

**1.7.1**

Figure 1.5. Heater and option connectors

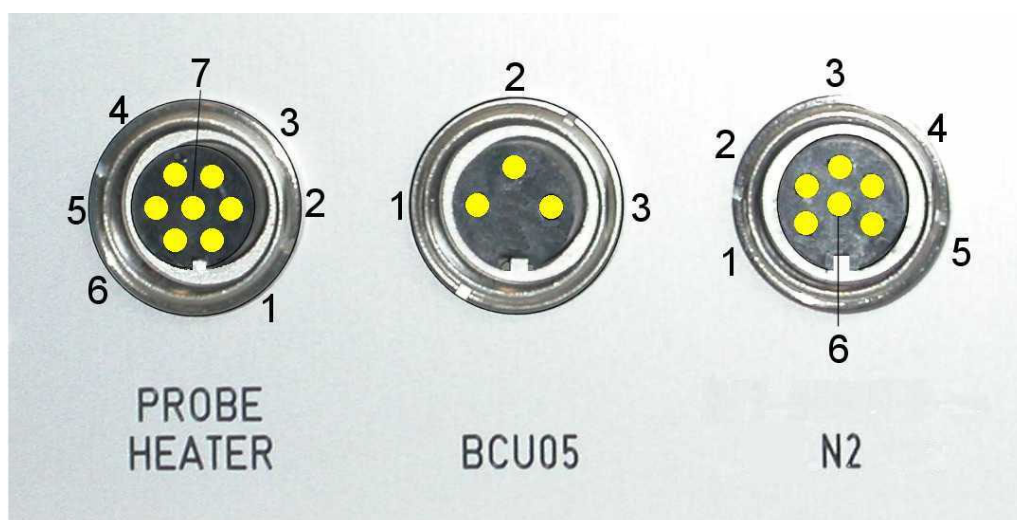

**EPR BVT Probe heater and N<sub>2</sub> option connectors presentation**

**1.7.2**

Figure 1.6. Heater and N<sub>2</sub> option connectors

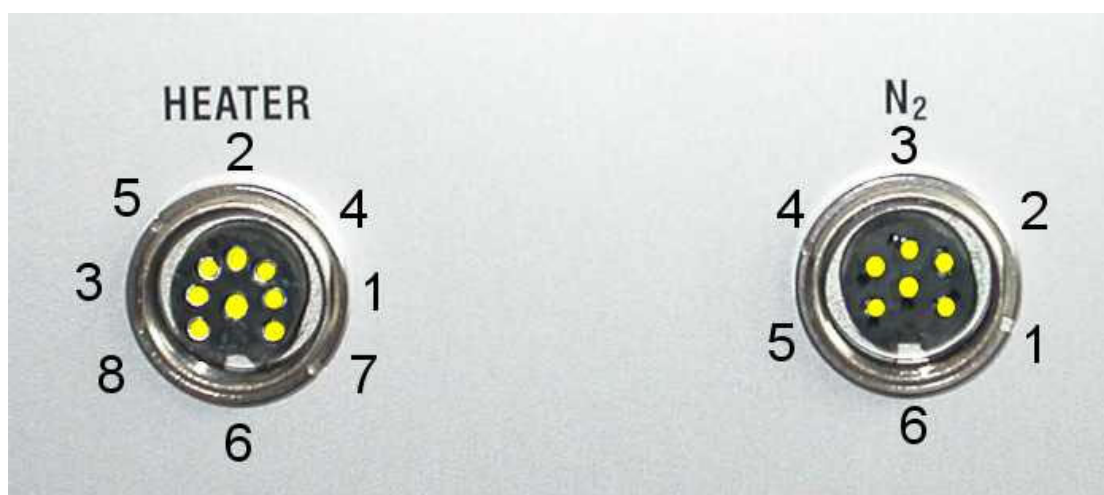

**Probe heater connector pin out**

The probe heater connector is a round 7 pin female model connector.

Table 1.2. Heater connector pin assignment

PIN	7 pins NMR	8 pins EPR
1	Heater +	Heater +
2	Heater +	NC
3	Security thermocouple +	Heater -
4	Security thermocouple -	Security thermocouple +
5	Heater -	Security thermocouple -
6	Heater -	Frame
7	Frame	Heater +
8	NC	Heater -

**BCU05 connector pin out**

The BCU05 connector is a round 3 pin female model connector. Not available on ESR BVT's.

Table 1.3. BCU05 connector pin out assignment

PIN	SIGNAL
1	BCU05 on/off
2	DGND
3	Not connected

**N<sub>2</sub> Option connector pin out**

The N<sub>2</sub> connector is a round 6 pin female model connector.

Table 1.4. Evaporator connector pin out assignment

PIN	Exchanger signal	Evaporator signal
1	PT100 heater +	Evaporator heater +
2	Level PT100+	Level PT100+
3	Not used	Evap detection (=gnd)
4	GND	GND
5	GND	GND
6	Exch. detection (= gnd)	Not used

**Pt100 connector**

Figure 1.7. Pt100 connector (Front view)

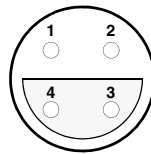

Table 1.5. PT100 connector pin assignment

PIN	SIGNAL
1	current -
2	measure -
3	measure +
4	current +



*This connector is also used to connect the BTO2000. Pin 2 and 3 are used as signal input pins.*

## Thermocouple connector

Figure 1.8. Thermocouple connector (Front view)

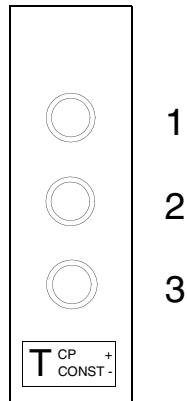

Table 1.6. Thermocouple T pin assignment

PIN	SIGNAL
1	(Cu) Shield
2	(Cu) Thermocouple +
3	(Co.) Thermocouple -

Table 1.7. Thermocouple K pin assignment

PIN	SIGNAL
1	Shield
2	(Cr) Thermocouple +
3	(Al) Thermocouple -

## RS232 connector

Figure 1.9. RS232 male connector (Front view)

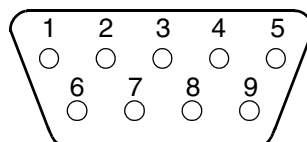
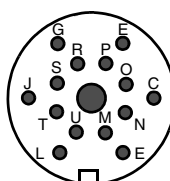

Table 1.8. RS232 connector pin assignment

PIN	SIGNAL
1	nc
2	RxD
3	TxD
4	nc
5	gnd
6	nc
7	RTS
8	DTR
9	nc

**BVTB Connector**

Figure 1.10. BVTB 3500 connector (Front view)



## Description

Table 1.9. BVTB 3500 connector pin assignment

PIN	SIGNAL NAME	DIRECTION	COMMENT
A	+5V	O	digital vcc output
C	NC	---	reserved
E	gnd_BTO	O	BTO2000 has an isolated supply GND
G	+15 v_BTO	O	BTO2000 has an isolated supply +15V
J	NC	---	reserved
L	dgnd	O	digital ground
M	sda	I/O	I2C bus data line
N	scl	I/O	I2C bus clock line
O	power control	O	0 to 10 volt power control output
P	pgnd	O	power ground
R	pgnd	O	power ground
S	thermocouple	I	safety thermocouple input
T	b_relay	O	BVTB 3500 heater relay command
U	b_connected	I	if grounded BVTB 3500 is detected

The BVTB3500 is a power booster for the BVT3000.



## **BASM - Auxiliary sensors module**

## **2.1**

The BVT3000 can be equipped with an electronic module for auxiliary temperature measurement.

This module can receive up to 4 sensors to acquire more temperature in spectrometer environment (ambient temperature, extra temperature in special probe head for example).

Figure 2.1. BASM front view



The module is inserted in the front panel of the BVT3000 unit and is connected to the main board with a flat cable.

Three models are available.

Table 2.1. BASM Type

Part number	BASM Type
W1101182	4 x PT100
W1101183	4 x Thermocouple K
W1101184	2 x Th. E + 2 x Th. T

The BMCM is an electronic module which allows to control manually the main functions of the temperature unit.

Figure 2.2. BMCM Front view

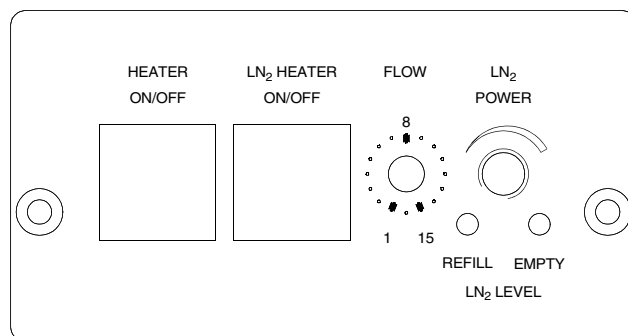

The following functions of the temperature unit can be controlled:

- Probe Heater: the left push button of the module turns on the main probe heater. The heater status is indicated by a green led in the button.
- LN<sub>2</sub> Heater: the right push button turns on the LN<sub>2</sub> evaporator heater. The LN<sub>2</sub> evaporator heater status is indicated by a green led in the button. The status of the LN<sub>2</sub> level sensors are indicated by two red leds on the bottom. The LN<sub>2</sub> heater power can be set with rightmost potentiometer.
- Gas flow control: a knob permits to select manually stepwise a gas flow between 0 and 2000 l/h.

The module is inserted in the front of the BVT3000 unit and has 4 flat cables which are connected on the interface board.

## Low temperature options

## 2.3

For sample temperature regulation below room temperature one must use cold gas. The BVT3000 can be equipped with 3 optional cold gas production devices:

- Liquid nitrogen exchanger.
- Liquid nitrogen evaporator.
- BCU05 gas cooler.

The level of the liquid nitrogen tank is monitored by software and the power level applied to the liquid nitrogen heater is computer controlled. The liquid nitrogen heater cable or the exchanger cable is plugged in the N<sub>2</sub> option connector on the front panel.

LN<sub>2</sub> exchanger and evaporator are available with plastic or stainless steel transfer line.

Plastic transfer line are not able to reach temperature lower than -85°C.

Only the use of the stainless steel transfer line allows the reach of temperature down to -135°C.



---

*BVT3000 are always delivered with the option board installed.*

---

## Liquid nitrogen exchanger

2.4

This option allows the regulation of temperature to be extended below room temperature. It is necessary to have a nitrogen gas line to use this device. The nitrogen gas is cooled by circulation in a tube bathed in liquid nitrogen. The cold gas is subsequently transferred to the probe through a flexible transfer line.

Regulation accuracy is unchanged.



*The gas flow is stopped (meaning all four valves are closed) whenever the heater power is off. This avoids sample freezing.*

### Exchanger presentation

2.4.1

Figure 2.3. Exchanger principle

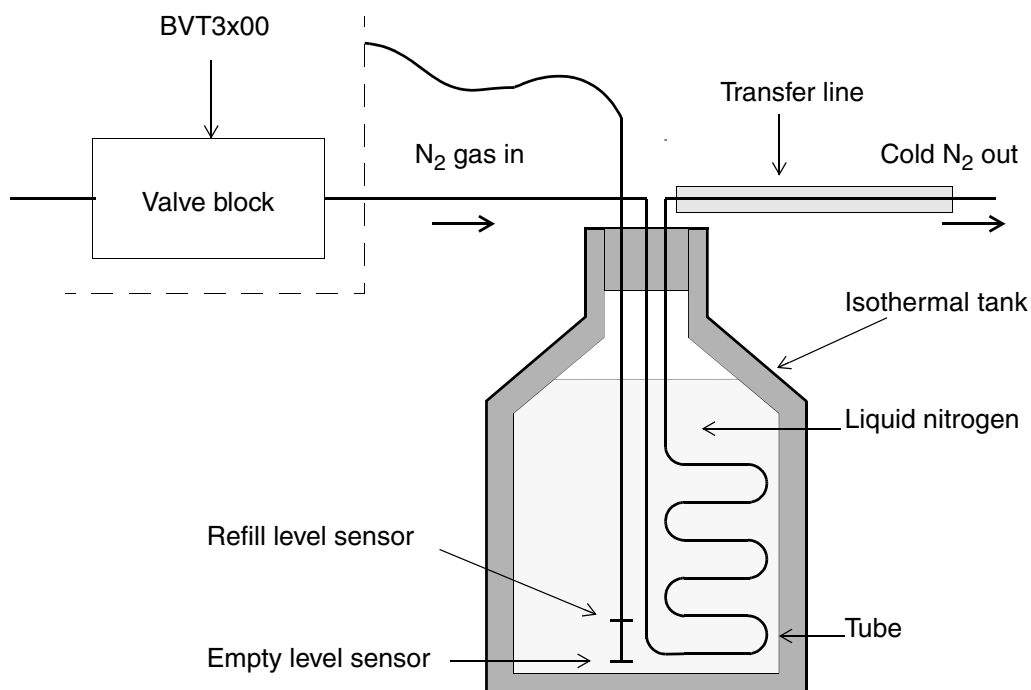

**Liquid nitrogen evaporator****2.5**

This device is a cold gas generator that allows low temperature sample regulation. The nitrogen gas is produced by evaporating the liquid nitrogen contained in an isothermal tank with an electric heater. The power delivered to the heater, controlled by software, may reach 200 Watts. The cold gas is transferred to the probe through a flexible transfer line.

**Evaporator presentation****2.5.1**

Figure 2.4. Evaporator principle

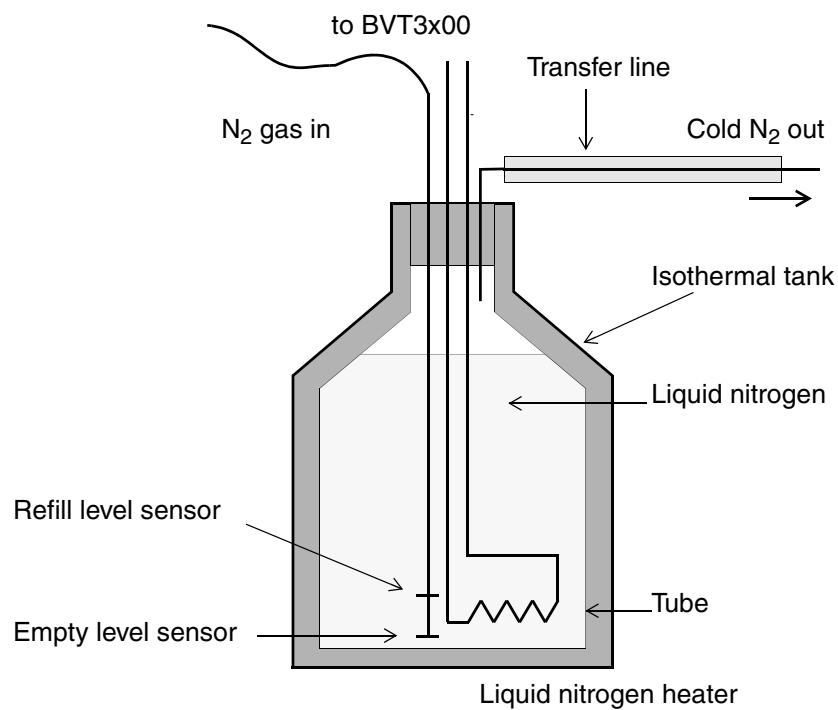

The BCU05 is a device that cools dry air or nitrogen gas. The device comprises a gas circuit with a gas compressor, an evaporator and a cooler. The gas is cooled as it circulates through the evaporator which is located inside the isolated transfer line. At the outlet of the transfer line the gas temperature may reach - 40°C.

The BCU05 has a cable which must be connected to the BVT3000 on the connector marked BCU05. When the heater is **ON** a signal is delivered to turn on the compressor of the BCU05. This security avoids freezing of the sample when the BVT3000 power is off.

Figure 2.5. BCU05 gas cooler

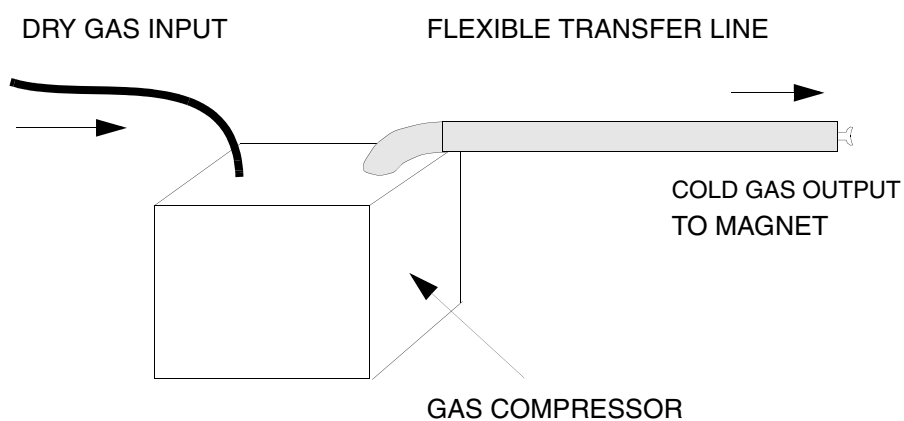

# Configuration

# 3

## Sensor selection

3.1

The BVT3000 can be used with different types of sensors:

- Thermocouple T or E for NMR, and K for EPR spectrometer
- BTO2000
- PT100 sensor



---

*Never connect two types of sensors at a same time on the BVT3000.*

---

## Eurotherm 2416 configuration

3.2

The 2416 controller can be configured to accept T, K, E, BTO2000 or PT100 temperature sensor. Configuration can be done with the 2416 keypad or with the EDTE software on NMR spectrometers.

You will find, on next page, the keypad configuration method.

Buttons are numbered from the left to the right.

# Configuration

Table 3.1. Keypad configuration

Step	Action	Display	Comment
1	Push button 1 until	ACCS / List	
2	Push button 2	Code / 0	
3	Push button 4 until	Code / 1	
4	Push button 2	Goto / Oper	
5	Push button 4 until	Goto / Conf	
6	Push button 2	Conf / 0	
7	Push button 4 until	Conf / 2	
8	Push button 1	Inst / Conf	
9	Push button 1 until	IP / Conf	
10	Push button 2	InPt / xxxx	xxxx is the actual sensor type Select the new sensor type with button 3 or 4
11	Push button 2	CJC / auto	Select "Auto" with T or K thermocouples or "0°C" with BTO Use button 3 or 4
12	Push button 1 until	Exit / no	
13	Push button 4	Exit / YES	Exit configuration mode

Table 3.2. Sensor and CJC type

Sensor	2416 name	CJC
Th T	t. tc	Auto
BTO2000	t. tc	0°C
Th K	k. tc	Auto
PT100	Rtd	/

\* CJC stands for cold junction compensation



# Remote interface control

# 4

## Microcontroller interface

## 4.1

This interface has several functions :

- Host computer - EURO THERM transparent communication through a serial port,
- Transmission of BVT3000 internal status to the host computer,
- Probe heater on/off control,
- Gas flow control,
- Installed option control with :
  1. Evaporator heating power control,
  2. Exchanger control with nitrogen level detection,
  3. Etc...

Optoisolated inputs receive information and security flags :

- Probe heater overheating flag,
- Gas flow detection,
- Liquid nitrogen level monitoring (when option available),
- Probe heater power status flag (on / off),
- etc...

Eight optoisolated outputs (**PORT3**) transmit the control byte for the DAC that delivers the liquid nitrogen heater control signal.

## Digital interface specifications

## 4.2

### Microcontroller

- 8 bits 8032 microcontroller clocked at 11,05 MHz.

### Program Memory

- Flash EPROM 64 Kilobytes. A new firmware can be downloaded into this memory via the RS232 link.

### Sram

- 32 Kilobytes.

### **Eeprom**

- 256 bytes for manufacturing informations storage (BBIS informations).

### **Interface**

- Serial link to EURO THERM controller :  
9600 bauds, 1 start bit, even parity, 1 stop bit and three link wires. The baudrate can be changed through the software using the «CO» command.
- Serial link to host computer :  
9600 bauds, 1 start bit, even parity, 1 stop bit and three wires link.

### **Isolation**

- Optocouplers 2500V isolation between digital interface and power section.

### **Power supply**

- +5V / I < 1 ampere.

## **Commands and communication protocol**

**4.3**

All commands for the Eurotherm controller cross over the interface. The micro-controller decodes each received command and then decides for what component the command is intended (either for the interface itself or the Eurotherm controller). A command that is not an interface command is automatically transferred to the Eurotherm controller. If the command is processed by the Eurotherm, the answer is returned to the host computer via the interface.

## **Control Characters**

**4.4**

Six non printing ASCII characters are used to control the messages that are exchanged between host computer and BVT3000.

Table 4.1. Control characters

NAME	HEX	FUNCTION
STX	02	Start of text
ETX	03	End of text
EOT	04	End of transmission
ENQ	05	Enquiry
ACK	06	Acknowledge
NACK	15	Negative acknowledge

**List of commands****4.5**

Table 4.2. List of commands

COMMANDS	R	W	COMMENT
AF	X	X	reads / writes gas flow delivery
CM	X		starts a ram test of the microcontroller (for test only)
CO	X	X	reads / writes communication speed (interface <-> Eurotherm)
DL	X	X	reads the download transfer status / initialises a download transfer
DT		X	DAC check (for test only)
ES	X		reads the error status
HP	X	X	reads / writes heater power state ('1' or '0')
IS	X		reads interface status
NH	X	X	reads / writes LN <sub>2</sub> heater power level
NP	X	X	reads / writes LN <sub>2</sub> heater power level ('1' or '0')
P1	X	X	reads / writes port 1 (for test only)
P2	X	X	reads / writes port 2 (for test only)
P3	X		reads port 3 (for test only)
P4	X		reads port 4 (for test only)
SV	X		reads interface version (software, hardware and installed options)
RB		X	reads BBIS memory content
WB		X	writes to a BBIS memory location
WR		X	writes a record to the BVT3000
XR		X	transmit a hexadecimal record to the host

**RS232 link characteristics****4.6**

The serial link allows a host computer to communicate with the BVT3000. It is a three wire link with no hardware or software handshake. The communication parameters are 9600 bauds, 1 start bit, even parity, 1 stop bit. The RS232 connector pin assignment and naming is explained in **"RS232 connector pin assignment" on page 15.**

A cable with two 9 pins female connectors is required to link the host computer to the BVT3000. The maximum recommended cable length is 10 meters (30 feet). The cable shield is connected to the connector's case.

Figure 4.1. RS232 cable

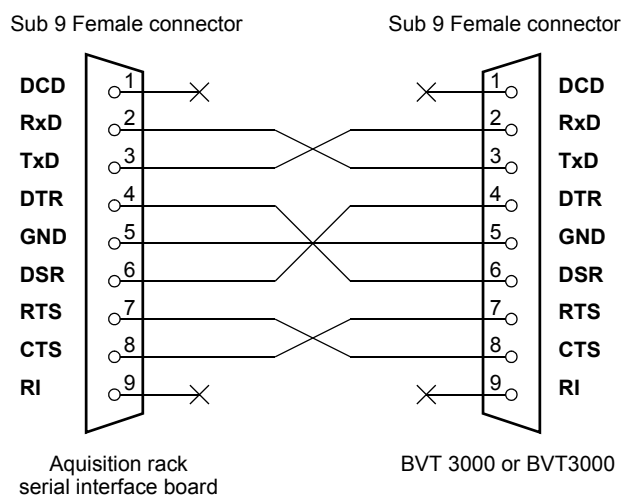

The microcontroller automatically detects the installed optional board (Liquid nitrogen evaporator or liquid nitrogen exchanger) and any devices connected via the front panel (ie. exchanger or evaporator). The firmware authorises only the use of the functions relative to the installed options. Let us suppose, for instance, that the N exchanger is installed: you cannot use the evaporator functions. The answer to an unauthorised function will be a «**NACK**». The following table lists the possible options and the corresponding authorised functions. In this table «**X**» indicates an authorised function while an empty cell indicates an unauthorised function.

Table 4.3. Authorised commands

COMMANDS	STANDARD	WITH EVAPORATOR	WITH EXCHANGER	PROBLEM
AF	X	X	X	X
CM	X	X	X	
CO	X	X	X	
DL	X	X	X	
DT	X	X	X	
ES	X	X	X	
HP	X	X	X	
IS	X	X	X	X
NH		X		
NP		X		
P1	X	X	X	X
P2	X	X	X	X
P3	X	X	X	X
P4	X	X	X	X
SV	X	X	X	X
RB	X	X	X	X
WB	X	X	X	X
WR	X	X	X	X
XR	X	X	X	X

## AF (Air flow)

## 4.8.1

### Write

Syntax : EOT 0 0 0 0 STX **AF**>ABCD ETX BCC

Response : ACK

Description : This command allows to control the gas flow delivery.

Rules : The unit has four gas flow valves. ABCD represents the value of the delivery. Each character represents one valve state (a part of the maximum delivery) and can only be «0» or «1». The total delivery is the amount of the four individual deliveries. A NACK is sent if one of these characters is not «0» or «1». Table ***"Flow rate versus command" on page 10*** shows the different gas flow deliveries.

Example : If ABCD is set to «1100» (12 decimal), the delivery corresponds to 1600 litres per hour.

## Remote interface control

**NB** : After power on the microcontoller reads 4 jumpers (JP6-JP8) located on the interface printed circuit. Each jumper can be switched between positions marked «1» and «0». Each jumper represents a valve ; in position «0» the valve will be closed. JP6 represents valve D and JP8 valve A. The initial flow rate is set according to the combination of all jumpers.



---

*Space characters are not allowed.*

---

### **Read**

Syntax : EOT 0 0 0 0 **AF** ENQ

Response : STX **AF** > Value ETX BCC

Description : This command allows gas flow delivery to be controlled.

Rules : Value is a 4 characters string. Table "***Flow rate versus command***" on page 10 shows the different gas flow deliveries.

---

### **CM (Check memory for test only)**

**4.8.2**

### **Read**

Syntax : EOT 0 0 0 0 CM ENQ

Response : ACK if the RAM test has complete.

NACK if the test failed.

Description : CM starts a complete RAM test.



---

*After the (ACK or NACK) the interface answers always RESET?*

---

---

### **CO (Communications speed)**

**4.8.3**

### **Write**

Syntax : EOT 0 0 0 0 STX **CO** ABCDE ETX BCC

Response : ACK

Description : CO command allows to program the Eurotherm - interface speed communication. After power on, speed communication is set to 9600 Bauds.

Rules : ABCDE represent the baud rate. It is a five characters string. This string can have one of the following values :

A	B	C	D	E
1	9	2	0	0
_	9	6	0	0
_	4	8	0	0
_	2	4	0	0
_	1	2	0	0

**NB** : «\_» represent the space character. It can be replaced by '0'.

**Read**

Syntax : EOT 0 0 0 0 STX **CO** ENQ

Response : STX CO ABCDE ETX BCC

Description : It allows to read the Interface - Eurotherm communication speed.

Rules : «ABCDE» represents the baud rate. It is a 5 characters string. The string is allowed to have the following values:

```

A B C D E
1 9 2 0 0
_ 9 6 0 0
_ 4 8 0 0
_ 2 4 0 0
_ 1 2 0 0
    
```

**NB** : «\_» represents the space character.

**DL (Download)**

**4.8.4**

**Write**

Syntax : EOT 0 0 0 0 STX **DL** val ETX BCC

Response : ACK if command issues.

NACK in all other cases.

Description : DL initializes download. This command must be repeated two times successfully to enter in the mode which allows the host to transfer code.

Take care : Flash Eprom is erased on the second DL command. On second DL1 command, regulation is interrupted. Heater, evaporator and gas flow are switched off. All the software user functions are inaccessible.

Rules : Val can be «0» or «1».

- «0» stops download. If the download is in progress, a new one must be performed completely to make the BVT3X00 run correctly.
- «1» initializes download. The «DL1» command must be sent twice to start the process (FLASH erased).

**Read**

Syntax : EOT 0 0 0 0 **DL** ENQ

Response : STX **DL** val ETX BCC

Description : Allows the user to get information about download.

Rules : Val = '0': No download in progress.  
 Val = '1': download in progress but flash eprom is not erased.  
 Val = '2': download in progress and flash eprom is erased.

#### **Write**

Syntax : EOT 0 0 0 0 DT state ETX BCC

Response : ACK

Description : DT starts a liquid nitrogen DAC test.

Rules : state can be «0» or «1».  
1 means test on.  
0 means test off.

#### **Read**

Syntax : EOT 0 0 0 0 **ES** ENQ

Response : STX **ES** val ETX BCC

Description : Allows the user to get information about the last six errors.

Explanations : At each «ES» request, the last happened error code is sent and then reset. If more than six errors are memorised, the oldest error code is replaced by the new one. To erase all errors, the user must sent «ES» requests until response is «ES0».

The returned value «Val» informs the user about errors. The different error codes are given below.

#### **Write**

Syntax : EOT 0 0 0 0 STX **ES** val ETX BCC

Response : Always NACK.



Table 4.4. Error status description

VAL	SIGNIFICATION	COMMENT
0	NOERROR	no error in command
1	SYNTAX	unknown command/syntax error
2	checksum	checksum error
3	erasefail	flash eprom erase error
4	programmfail	flash eprom program error
5	wrongrecordtype	no intel hex record
6	wrongaddress	program address out of range
7	wrongchecksum	checksum error intel hex
8	wrongtransmissioncheck	wrong eof record
9	wrongdatacount	byte counter error
10	noappsw	no application software
11	nobbis	no BBIS available
12	bbiscs1	BBIS checksum error block 1
13	bbiscs2	BBIS checksum error block 2
14	bbiscs3	BBIS checksum error block 3
15	bbiscs4	BBIS checksum error block 4

**HP (Heater power)**

**4.8.7**

**Write**

Syntax : EOT 0 0 0 0 STX **HP** state ETX BCC

Response : ACK If state equals «0» or «1»

NACK In all other cases

Description : This command allows gas flow heating to be switched ON or OFF.

Rules : State can be «0» or «1».  
 «1» switch the heater ON  
 «0» switch the heater OFF  
 All other values are ignored.



*Space characters are not allowed.*

## Remote interface control

### **Read**

Syntax : EOT 0 0 0 0 **HP** state ENQ

Response : STX **HP** state ETX BCC

NACK In all other cases

Description : This command allows to read the heater's state.

Rules : State can be «0» or «1».  
«1» means the heater is ON  
«0» means the heater is OFF.

**NB** : after power on the heater is OFF.

### **IS (Interface status)**

**4.8.8**

### **Read**

Syntax : EOT 0 0 0 0 **IS** ENQ

Response : STX **IS** > ABCD ETX BCC

Description : This command allows the interface status to be read back.

Rules : The status word is made of sixteen bits, each one represents a particular function of the interface as detailed below. The 16 bits are sent as four hexadecimal numbers preceded by «>» to warn the computer that the data is hexadecimal. Digits ABCD are ASCII characters representing a hexadecimal digit (0-9, A-F).

Interface Status (IS) in the format (>ABCD)

Table 4.5. Interface status

DIGIT	BIT	SIGNAL NAME	FUNCTION
D1	0	heater on	1= heater is ON
D2	1	not used	always 0
D3	2	evap conn	1 = evaporator connected
D4	3	missing gas flow	1 = missing gas flow
C1	4	overheating	1 = heater overheating
C2	5	exch conn	1 = exchanger connected
C3	6	LN <sub>2</sub> refill	1 = refill LN <sub>2</sub> tank
C4	7	LN <sub>2</sub> empty	1 = LN <sub>2</sub> tank is empty
B1	8	evaporator status	1 = LN <sub>2</sub> heater is on
B2	9	not used	1 always
B3	10	booster connected	1 = BVTB3500 present
B4	11	reserved	0 always
A1	12	reserved	0 always
A2	13	reserved	0 always
A3	14	reserved	0 always
A4	15	reserved	0 always

**NH (Nitrogen heater)**

4.8.9

**Write**

Syntax : EOT 0 0 0 0 STX **NH** Value ETX BCC

Response : ACK

Description : This command allows the liquid nitrogen heater power (Evaporator) to be controlled.

Rules : The value from 0 up to 100%, is defined as a string up to 5 characters long. The string can begin with 1 to 5 spaces or «0». After power on, the initial value is set to 0 (the nitrogen heater is OFF).

**Read**

Syntax : EOT 0 0 0 0 **NH** ENQ

Response : STX **NH** Value ETX BCC

Description : This command allows the liquid nitrogen heater power to be read back.

Rules : Value from 0 to 100%, is a string up to 5 characters long. The string can begin with 1 to 5 spaces or «0».

**NB**: Value is a DECIMAL code.

**NP (Nitrogen heater power)**

4.8.10

**Write**

Syntax : EOT 0 0 0 0 STX **NP** state ETX BCC

Response : ACK

Description : This command allows the nitrogen heater power to be switched ON or OFF.

Rules : State can be «0» or «1».  
 «1» switch liquid nitrogen heater ON.  
 «0» switch liquid nitrogen heater OFF.



*Space characters are not allowed.*

**Read**

Syntax : EOT 0 0 0 0 **NP** ENQ

Response : STX **NP** State ETX BCC

Description : This command allows the nitrogen power to be read back.

Rules : State can be «0» or «1».  
 A equal «1» means that liquid nitrogen heater is ON  
 A equal «0» means that liquid nitrogen heater is OFF

**NB** : After power on the nitrogen heater power is at «0».

This port represents the main status of the BVT3000 unit.

Port 1 is described in the following table.

Table 4.6. Port 1 definition

BIT	NAME	FUNCTION
0	heater	1 = Probe heater is ON
1	aux1	Unused
2	evaporator	1 = LN <sub>2</sub> heater is ON (with option)
3	aux2	Unused
4	valve1	1 = Valve 1 open
5	valve2	1 = Valve 2 open
6	valve3	1 = Valve 3 open
7	valve4	1 = Valve 4 open

### Write

Syntax : EOT 0 0 0 0 STX **P1** AB ETX BCC

Response : ACK

Description : This command allows direct write access to port 1.

Rules : The first character represents the state of port 1 bits 4 to 7. The second character represents the state of the bits 0 to 3. The characters are hexadecimal.

### Read

Syntax : EOT 0 0 0 0 **P1** ENQ

Response : STX **P1** > ABCD ETX BCC

Description : Allows direct read access to port 1.

Rules : A and B are always «0». The third character represents the state of port 1 bits 4 to 7. The fourth character represents the state of the bits 0 to 3. All the characters are hexadecimal.

The power level applied to the liquid nitrogen evaporator is set by an analog control signal coming from an 8 bit DAC (Digital to Analog Converter). Port 2 provides the bits for liquid nitrogen control DAC:

Table 4.7. Port2 definition

BIT	NAME	FUNCTION
0	1LN <sub>2</sub>	DAC bit 0
1	2LN <sub>2</sub>	DAC bit 1
2	3LN <sub>2</sub>	DAC bit 2
3	4LN <sub>2</sub>	DAC bit 3
4	5LN <sub>2</sub>	DAC bit 4
5	6LN <sub>2</sub>	DAC bit 5
6	7LN <sub>2</sub>	DAC bit 6
7	8LN <sub>2</sub>	DAC bit 7

**Write**

Syntax : EOT 0 0 0 0 STX **P2** AB ETX BCC

Response : ACK

Description : Allows direct write access to port 2.

Rules : The first character represents the state of port 2 bits 4 to 7. The second character represents the state of the bits 0 to 3. The characters are hexadecimal.

**Read**

Syntax : EOT 0 0 0 0 **P2** ENQ

Response : STX **P2** > ABCD ETX BCC

Description : Allows direct read access to port 2.

Rules : A and B are always «0». The third character represents the state of port 2 bits 4 to 7 while the fourth character represents the state of the bits 0 to 3. All the characters are hexadecimal.

**P3 (Port 3 for test only)**

**4.8.13**

Port 3 allows the internal status of the BVT3000 to be read.

It is composed as follows:

Table 4.8. Port3 definition

BIT	NAME	FUNCTION
0	heater on	1 = probe heater is ON
1	booster connected	1 = BVTB3500 present
2	evap conn	1 = evaporator device is connected
3	no gas	1 = missing gas flow
4	overheating	1 = overheating on probe heater
5	exch conn	1 = Exchanger connected
6	LN <sub>2</sub> refill	1 = LN <sub>2</sub> tank is almost empty
7	LN <sub>2</sub> empty	1 = LN <sub>2</sub> tank is empty

### Read

Syntax : EOT 0 0 0 0 P3 ENQ

Response : STX P3 > ABCD ETX BCC

Description : Allows direct read access to port 3.

Rules : A and B are always «0». The third character represents the state of port 3 bits 4 to 7 while the fourth character represents the state of the bits 0 to 3. All the characters are hexadecimal.

## P4 (Port 4 for test only)

4.8.14

Port 4 allows the internal status of the BVT3000 to be read and allows the valves to be set at Power on.

It is composed as follows:

Table 4.9. Port 4 definition

BIT	NAME	FUNCTION
0	unused	
1	unused	
2	unused	
3	evap_on	1 = evaporator heater on
4	V1	jumper JP9
5	V2	jumper JP8
6	V3	jumper JP7
7	V4	jumper JP6

When a jumper is placed in position 1 it means that the valve is open at power on.

Figure 4.2. Valve jumpers settings

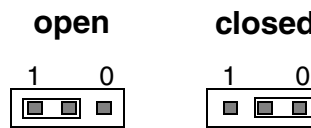

**Read**

Syntax : EOT 0 0 0 0 **P4** ENQ

Response : STX **P4** > ABCD ETX BCC

Description : Allows direct read access to port 4

Rules : A and B are always «0». The third character represents the state of port 3 bits 4 to 7 while the fourth character represents the state of the bits 0 to 3. All the characters are hexadecimal.

**RB (Read BBIS)**

**4.8.15**

**Write**

Syntax : EOT 0 0 0 0 STX **R B** adr\_e2prom A1 A0 ETX BCC

Response : STX **R B** > D0 D1 ETX

NACK if command can't issue.

Description : RB command allows a single byte to be read in a BBIS E2PROM

Rules : A1 and A0 are values from '0' up to 'F' representing the byte address in the E2PROM.

adr\_e2prom is a value from '0' up to '7' representing the I2C bus address of the E2PROM

- 0 : Address unused
- 1 : BVT3X00 motherboard address
- 2 : BVTB3500 (Booster) address
- 3 : Address unused
- 4 : Address unused
- 5 : Address unused
- 6 : Address unused
- 7 : Address unused

All other values generates a NACK response.

### Read

Syntax : EOT 0 0 0 0 **SV** ENQ

Response : STX **SV** Version ETX BCC

Description : Version is a 5 character code (SSHHO) where:

- **SS** represents the SOFT version
- **HH** represents the HARD version, and
- **O** indicates the installed OPTIONS

### Example

The string received is:

Hex : 02H 53H 56H 30H 31H 32H 33H 35H 02H 37H

Ascii : STX 'S' 'V' '0' '1' '2' '3' '5' ETX BCC

It means : SOFTWARE Version 0.1

HARDWARE Version 2.3

OPTIONS 5

The different identification options are defined as follows:

1. Thermocouple module option.
2. Liquid nitrogen Evaporator option.
3. Liquid nitrogen Evaporator option+ thermocouple module.
4. Liquid nitrogen Exchanger option.
5. Liquid nitrogen Exchanger option+ thermocouple module.
6. Problem detected.

### Write

Syntax : EOT 0 0 0 0 STX **W B** adr\_e2prom A1 A0 D1 D0 ETX BCC

Response : ACK if command issues

NACK in all other cases

Description :WB command allows a single byte to be written on a BBIS E2PROM

Rules : A1, A0 are values from '0' up to 'F' representing the address in the E2PROM.

D1, D0 are values from '0' up to 'F' representing the value to be written.

adr\_e2prom is a value from '0' up to '7' representing the I2C bus address of the E2PROM.



- 0 : Address unused
- 1 : BVT3X00 motherboard address
- 2 : BOOSTER address
- 3 : Address unused
- 4 : Address unused
- 5 : Address unused
- 6 : Address unused
- 7 : Address unused

All other values generate a NACK response

**WR (Write record)**

**4.8.18**

Intel-Hex format is used to download the firmware on flash-eprom. The file to transfer is generated with OHS51.EXE. Its file extension is «.HEX». This file is composed by several records. Each record is composed as shown below:

: L L A A A A T T D D D . . . . . D D C C Cr Lf

Table 4.10. Record format

FIELD	LENGTH	SIGNIFICATION
«:»(3A)	1	Record start
L	2	Record length
A	4	Record address
T	2	Type (00: Data record, 01: EOF record)
D	LL	Data's
C	2	Checksum

**Write**

Syntax EOT 0 0 0 0 STX **TR** Rec ETX BCC

Response : ACK if download is initialized and the record processing issues.

NACK in all other cases

Description : TR command allows records, extracted from a ".hex" file to be transferred to the BVT3X00.

Rules : Rec value represents an intel-hex record. First character («:»- ASCII 3A), Cr an Lf are suppressed.

### **Write**

Syntax : EOT 0 0 0 0 STX **X R** Val ETX BCC

Response : STX 0 0 0 0 X R Rec BCC

Description : This command is useful to save an active software file before processing a new download.

**Take care**: If Val = 1 -- Regulation is interrupted, heater, evaporator and gas flow are switched off making all software functions inaccessible.

Rules :  
Val = 0 : Stops the upload process.  
Val = 1 : Initializes upload process.  
Val = 2 : Authorizes the BVT3X00 to send the next record.  
Val = 3 : Asks the BVT3X00 to send the same record again.

The upload process is initialized by receiving «XR1» from the host computer. The BVT3X00 sends the first Intel-hex record. The BVT3X00 waits then for «XR2» to continue. This command authorizes the BVT3X00 to send the next record. This handshake continues until the BVT3X00 sends the last record which is «0 0 0 0 0 0 1 F F». The host computer must detect this record. Subsequently, BVT300 sends an "XR0" request to terminate the upload process and returns to normal mode.

If BVT3X00 receives an «XR3» command, the previous record is sent again.

An «XR0» Command must be sent to terminate the upload sequence and return to normal mode.

# Technical specifications

# 5

## Specifications

## 5.1

### Weight :

- 14Kg for basic version without any options.

### Dimensions :

- 445 / 484 mm wide (Body / Front panel)
- 130mm high
- 461mm deep

### Voltage requirements :

- 230V +6 / -10%, 50/60 Hz

### Power consumption :

- 250VA maximum for standard version.

### Inputs :

- T Thermocouple type with standard linearisation.
- PT100
- BTO2000

### Temperature stability :

- +/- 0.2 °C target temperature = room temperature +5°C to 200°C with T thermocouple. ( Room temperature must not change by more than +/- 1°C ).
- +/- 0.01 °C target temperature = room temperature +5°C to 50°C with BTO2000. ( Room temperature must not change by more than +/- 1°C ).

### Heater power :

- 136W (42V on 13 ohm probe heater with cable)

### Gas inlet :

- 4 bars mini, 8 bars maxi (dry air or N<sub>2</sub> gas)

### Gas flow rate :

- 200 l/h to 2000 l/h with 15 steps

### Options :

For regulation at low temperature following devices can be used :

- BCU05
- LN<sub>2</sub> exchanger

- LN<sub>2</sub> evaporator with 200W heater.

### Security fuses

### 5.2

Some important electronic functions are fuse protected. To replace a blown fuse, turn off the BVT3000 and disconnect the main power cord. A faulty fuse must always be replaced with the same type.

Table 5.1. Fuses values

Fuses	Value	Protection for
F1	1 AT	+5V digital
F2	6.3 AT	Heater resistor
F3	0.5 AT	+15V analog
F4	0.5 AT	-15V analog
F5	0.5 AT	+24V valve block
F6	0.5 AT	+15V BTO2000

# Figures

<b>1 Description</b>	<b>5</b>
Figure 1.1. BVT3000 block diagram .....	6
Figure 1.2. Parts location .....	7
Figure 1.3. BVT3000 front panel .....	8
Figure 1.4. Gas flow circuit .....	9
Figure 1.5. Heater and option connectors .....	11
Figure 1.6. Heater and N <sub>2</sub> option connectors .....	11
Figure 1.7. Pt100 connector (Front view) .....	13
Figure 1.8. Thermocouple connector (Front view) .....	14
Figure 1.9. RS232 male connector (Front view) .....	14
Figure 1.10. BVTB 3500 connector (Front view) .....	15
<b>2 Options</b>	<b>17</b>
Figure 2.1. BASM front view .....	17
Figure 2.2. BMCM Front view .....	18
Figure 2.3. Exchanger principle .....	20
Figure 2.4. Evaporator principle .....	21
Figure 2.5. BCU05 gas cooler .....	22
<b>3 Configuration</b>	<b>23</b>
<b>4 Remote interface control</b>	<b>25</b>
Figure 4.1. RS232 cable .....	28
Figure 4.2. Valve jumpers settings .....	39
<b>5 Technical specifications</b>	<b>43</b>

**Figures**

# Tables

<b>1</b>	<b>Description</b>	<b>5</b>
Table 1.1.	Flow rate versus command .....	10
Table 1.2.	Heater connector pin assignment .....	12
Table 1.3.	BCU05 connector pin out assignment .....	12
Table 1.4.	Evaporator connector pin out assignment .....	13
Table 1.5.	PT100 connector pin assignment .....	13
Table 1.6.	Thermocouple T pin assignment .....	14
Table 1.7.	Thermocouple K pin assignment .....	14
Table 1.8.	RS232 connector pin assignment .....	15
Table 1.9.	BVTB 3500 connector pin assignment .....	16
<b>2</b>	<b>Options</b>	<b>17</b>
Table 2.1.	BASM Type .....	17
<b>3</b>	<b>Configuration</b>	<b>23</b>
Table 3.1.	Keypad configuration .....	24
Table 3.2.	Sensor and CJC type .....	24
<b>4</b>	<b>Remote interface control</b>	<b>25</b>
Table 4.1.	Control characters .....	26
Table 4.2.	List of commands .....	27
Table 4.3.	Authorised commands .....	29
Table 4.4.	Error status description .....	33
Table 4.5.	Interface status .....	34
Table 4.6.	Port 1 definition .....	36
Table 4.7.	Port2 definition .....	37
Table 4.8.	Port3 definition .....	38
Table 4.9.	Port 4 definition .....	38
Table 4.10.	Record format .....	41
<b>5</b>	<b>Technical specifications</b>	<b>43</b>
Table 5.1.	Fuses values .....	44









**Bruker Corporation**

[info@bruker.com](mailto:info@bruker.com)  
[www.bruker.com](http://www.bruker.com)

Order No: Z31348