

# EPR Consumables and Accessories

an SP Industries Company



1172 NW Boulevard, Vineland, NJ 08360, USA

Tel: 800-220-5171 Fax: 856-691-6206

[www.wilmad-labglass.com](http://www.wilmad-labglass.com)

ISO 9001:2008  
Registered

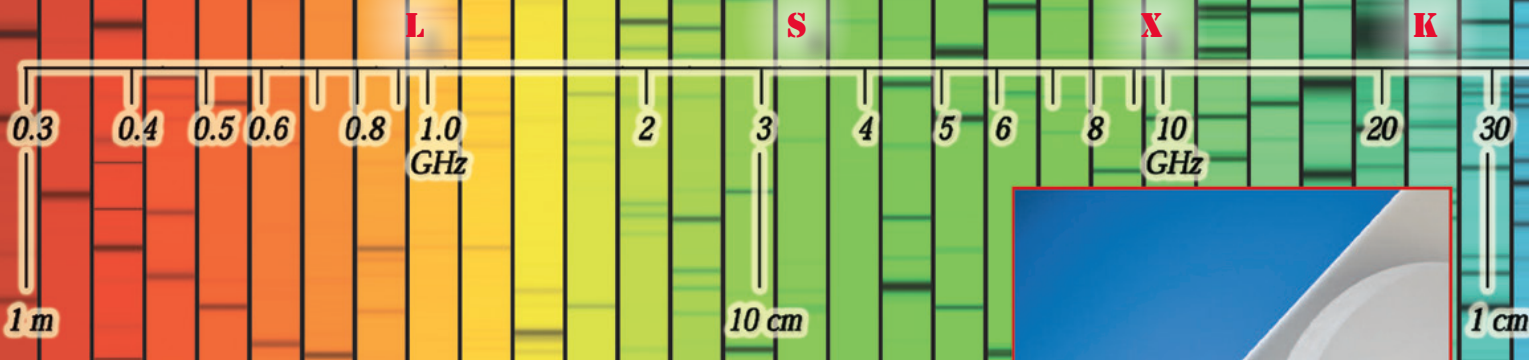

**E**lectron-Paramagnetic-Resonance (EPR), which is also known as Electron-Spin-Resonance (ESR), possesses a few advantages over Nuclear Magnetic Resonance (NMR) as:

- Larger Zeeman splitting yields greater SNR
- Nanosecond relaxation makes EPR suitable for real-time dynamic studies
- Spectrum fitting through Hamiltonian unveils geometry information
- Site-directed spin labeling (SDSL) technique could focus on limited number of spins at area of interest



### *Clear Fused Quartz (CFQ) vs. Suprasil*

Wilmad-LabGlass's EPR consumables are manufactured from naturally occurring quartz, which is also known as clear fused quartz, and synthetic quartz, which is recognized in industry as Suprasil. Due to different production process, Suprasil contains orders of magnitude less impurities and defects than clear fused quartz (see table below).

Thanks to technological advancements, the sensitivity of EPR has gradually increased over the past decades. This advancement also impacts EPR consumables as certain high Q cavities could pick up the EPR signal from impurities and defects in CFQ. We therefore discontinued some CFQ products and recommend choosing Suprasil products to guarantee a clean background signal for tubes with an outer diameter of over 4 mm.

For photochemistry studies, the cut-off wavelength is 265 nm for CFQ and 190 nm for Suprasil.

**The market of quartz is volatile. Prices shown in this catalog are based on raw material cost in April 2011, and subject to change without notice.**

Material	Al	Ca	Cr	Cu	Fe	K	Li	Mg	Mn	Na	Ti	Zr
CFQ	15	0.5	<0.05	<0.05	0.1	0.4	0.6	0.05	<0.05	0.3	1.1	0.7
Suprasil	<0.05	<0.05	<0.05	<0.05	<0.05	<0.05	<0.05	<0.05	<0.05	<0.05	<0.05	<0.05

### *Economy Brand vs. Precision Brand*

Precision Brand EPR tubes hold 10-15 times tighter tolerance on the inner diameter, and >5 times smaller camber and concentricity over Economy Brand tube. Precision tubes are recommended for cw-experiments that require a constant filling factor or reproducibility on sample volume in the cavity.

 Toll Free: **1-800-220-5171**  
Intl.: **856-691-3200**  
**Phone**

 Toll Free: **1-800-220-1081**  
Intl.: **856-691-6206**  
**Fax**

 [www.wilmad-labglass.com](http://www.wilmad-labglass.com)  
[cs@wilmad-labglass.com](mailto:cs@wilmad-labglass.com)  
**Web**

## **Wilmad-LabGlass #1 IN EPR CONSUMABLES WORLDWIDE**

WILMAD was established in 1951 to produce precision glass tubing. Manufacturing techniques pioneered by WILMAD permit creation of tubing with dimensional tolerances as small as ±5 microns. The commitment to excellence that led to these developments has made WILMAD the world leader in precision glass tubing.

© 2011, WILMAD-LABGLASS, All Rights Reserved.

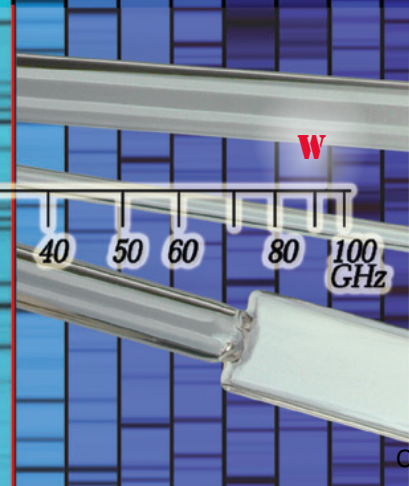

### L to W Band Standard Tubes

L, S and X Band Standard Economy Tubes	2
L, S and X Band Standard Precision Tubes	2
X Band Capillary Tubes for Aqueous Sample	3
X Band High Temperature Tubes	4
Q Band Tubes	4
W Band Tubes	4
Tube Caps	5

### Gas-tight Tubes

Constricted Vacuum Tube and Tip-Off Manifolds	6
Low Pressure/Vacuum Tube	7
Screw-Cap Tube	7
Quick Pressure Valve Tube	8
Pressure/Vacuum Tube	9
Omni-Fit Tube	11
Select-A-Product Guide for Gas-Tight Tubes	12

### EPR Reference Standard

X and Q Band Reference Standards	13
----------------------------------	----

### EPR Accessories

Tube Washers	14-15
Tube Racks	15
Liquid Nitrogen Dewar Flask	16
Combination pH Electrodes	16
Pipettes	17
Sample Filter	17
Stainless Steel Micro-Spatula	17
Hamilton Gas-Tight Syringe and Needles	18
Single Crystal Mounting Rod	19

### X Band Aqueous Cells

Standard TE <sub>102</sub> Cell	19
Standard TM <sub>110</sub> Cell	20
JEOL Cell	20
Small Volume VT TE <sub>102</sub> Cell	21
Large Volume VT TM <sub>110</sub> Cell	21
Tissue Sample Cell	21
Room Temperature Flow Cell	22
Variable Temperature Flow Cell	22
Electrolytic Cell	22

### Variable Temperature Dewar Inserts and Flasks

Variable Temperature Dewar Insert	23
Universal High Temperature Dewar Insert	24
High Temperature Dewar Insert for Bruker ER4114HT	24
TM110 Aqueous Cell Dewar Insert for Bruker	24
Room Temperature Simple Dewar Insert	24
Cold Finger Liquid Nitrogen Dewar Flask	25
Dewar Insert for Loop-gap Cavity	26

### Transfer Lines

Simple Transfer Line	26
Transfer Line with Heater Inlet	27
Immersion Transfer Line	27

## L to W Band Standard Tubes

### L, S and X Band Standard EPR Tubes | Economy Brand<sup>1</sup>

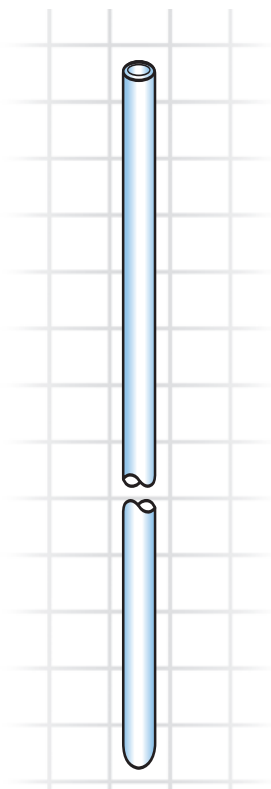

Each EPR tube comes with a disposable grade cap

#### Clear Fused Quartz<sup>3</sup>

	Product No.	Length (mm)	O.D. (mm)	I.D. (mm)	Wall Thickness (mm)
5 mm	710-SQ-100M	100	5.0	4.0±0.2	0.5
	710-SQ-250M	250	5.0	4.0±0.2	0.5
4 mm	707-SQ-100M	100	4.0	3.0±0.2	0.5
	707-SQ-250M	250	4.0	3.0±0.2	0.5
2 mm	712-SQ-100M	100	2.0	1.0±0.2	0.5
	712-SQ-250M	250	2.0	1.0±0.2	0.5

#### Suprasil<sup>4</sup>

	Product No.	Length (mm)	O.D. (mm)	I.D. (mm)	Wall Thickness (mm)
5 mm	730-SQ-100M	100	5.0	3.4±0.2	0.8
	730-SQ-250M	250	5.0	3.4±0.2	0.8
4 mm	727-SQ-100M	100	4.0	2.4±0.2	0.8
	727-SQ-250M	250	4.0	2.4±0.2	0.8
2 mm	724-SQ-100M	100	2.0	1.0±0.2	0.5
	724-SQ-159M	250	2.0	1.0±0.2	0.5

### L, S and X Band Standard EPR Tubes | Precision Brand<sup>2</sup>

#### Clear Fused Quartz<sup>3</sup>

	Product No.	Length (mm)	O.D. (mm)	I.D. (mm)	Wall Thickness (mm)	Concentricity (µm)	Camber (µm)
10 mm	713-5PQ-200M <sup>5</sup>	178	10.00±0.013	9.07±0.013	0.46	76	38
	700-PQ-7	178	4.97±0.013	2.16±0.013	1.40	102	102
5 mm	701-PQ-7	178	4.97±0.013	3.43±0.013	0.76	102	102
	702-PQ-7	178	4.97±0.013	4.20±0.013	0.38	102	102
4 mm	714-PQ-100M	100	4.00±0.013	3.20±0.013	0.40	51	51
	714-PQ-7	178	4.00±0.013	3.20±0.013	0.40	51	51
	714-PQ-8	203	4.00±0.013	3.20±0.013	0.40	51	51
	715-PQ-250M	250	4.00±0.013	3.20±0.013	0.40	51	76
3 mm	706-PQ-9.50	241	3.80±0.013	2.79±0.013	0.51	102	102
	705-PQ-6.25	159	2.97±0.013	1.99±0.013	0.48	76	76
2 mm	704-PQ-100M	100	1.99±0.013	1.02±0.013	0.48	76	76
	704-PQ-6.25	159	1.99±0.013	1.02±0.013	0.48	76	76

**NOTE 1, 2, 3, 4:** For detailed comparison between Precision Brand and Economy Brand, and between Clear Fused Quartz and Suprasil, please check back of the front cover page.

**NOTE 5:** 713-5PQ-200M is not recommended for high Q EPR cavities, such as Bruker's SHQE and SHQ.



## L, S and X Band Standard EPR Tubes | Precision Brand

Suprasil

	Product No.	Length (mm)	O.D. (mm)	I.D. (mm)	Wall Thickness (mm)	Concentricity (μm)	Camber (μm)
10 mm	733-3PQ-7	178	10.00±0.013	9.07±0.013	0.46	76	38
	733-3PQ-200M	200	10.00±0.013	9.07±0.013	0.46	76	38
8 mm	748-PQ-7	178	8±0.013	6.990±0.013	0.51	76	38
5 mm	721-PQ-7	178	4.97±0.013	3.43±0.013	0.76	102	102
	722-PQ-7	178	4.97±0.013	4.20±0.013	0.38	102	102
4 mm	735-PQ-100M	100	4.00±0.013	3.20±0.013	0.40	51	76
	734-PQ-7	178	4.00±0.013	3.20±0.013	0.40	51	51
	734-PQ-8	203	4.00±0.013	3.20±0.013	0.40	51	51
3 mm	735-PQ-250M	250	4.00±0.013	3.20±0.013	0.40	51	76
	726-PQ-9.50	241	3.80±0.013	2.79±0.013	0.51	102	102
	725-PQ-159M	159	2.96±0.013	1.99±0.013	0.48	76	76

## X Band Capillary Tubes for Aqueous Sample

Clear Fused Quartz

Product No.	Description	O.D. (mm)	ID. (mm)	Length (mm)	Package Qty.
Q-.3X.40	Both Ends Open	0.40	0.30	100	75
Q-.4X.55	Both Ends Open	0.55	0.40	100	75
Q-.5X.70	Both Ends Open	0.70	0.50	100	75
Q-.6X.84	Both Ends Open	0.84	0.60	100	75
Q-.7X.87	Both Ends Open	0.87	0.70	100	50
Q-.8X1.0	Both Ends Open	1.00	0.80	100	50
Q-.9X1.1	Both Ends Open	1.10	0.90	100	50
Q-1.0X1.2	Both Ends Open	1.2	1.0	100	25
Q-1.5X1.8	Both Ends Open	1.8	1.5	100	25
Q-2.0X2.4	Both Ends Open	2.4	2.0	100	25



Suprasil

Product No.	Description	O.D. (mm)	ID. (mm)	Length (mm)	Package Qty.
S-.3X.40	Both Ends Open	0.40	0.30	100	75
S-.4X.55	Both Ends Open	0.55	0.40	100	75
S-.5X.70	Both Ends Open	0.70	0.50	100	75
S-.6X.84	Both Ends Open	0.84	0.60	100	75
S-.7X.87	Both Ends Open	0.87	0.70	100	50
S-.8X1.0	Both Ends Open	1.00	0.80	100	50
S-.9X1.1	Both Ends Open	1.10	0.90	100	50
S-1.0X1.2	Both Ends Open	1.2	1.0	100	25
S-1.5X1.8	Both Ends Open	1.8	1.5	100	25
S-2.0X2.4	Both Ends Open	2.4	2.0	100	25

## X Band High Temperature Tubes

Wilma-LabGlass designed this sample tube for Bruker's ER4114HT cavity. The  $\frac{7}{15}$  taper joint fits to DWGSK3352 high temperature dewar insert on page 24.

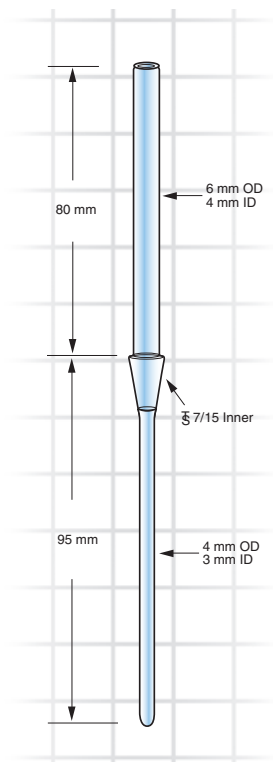

### Clear Fused Quartz

Product No.	OAL Length (mm)	Bottom O.D. (mm)	Bottom I.D. (mm)	Wall Thickness (mm)
750-PQ-7.1	190	4.0	3.0	0.5

## Q Band Standard EPR Tubes

Q-band is the most popular frequency for pulsed and cw-EPR after X-band. The larger Zeeman splitting would benefit EPR studies by (1) improving SNR, (2) requiring less sample, (3) resolving individual components of the g-matrix, (4) disentangling spectra which overlap at X-band, and (5) changing the spectral contribution interaction to field-independent interactions.

Wilma-LabGlass offers high quality EPR consumables to cover these high frequency applications.

### Clear Fused Quartz

Product No.	Length (mm)	O.D. (mm)	I.D. (mm)	Ends	Package Qty.
WG-221T	100	1.6	1.1	Both Ends Open	10
WG-221T-RB	100	1.6	1.1	One End Sealed	10

### Suprasil

Product No.	Length (mm)	O.D. (mm)	I.D. (mm)	Ends	Package Qty.
WG-222T	100	1.6	1.1	Both Ends Open	10
WG-222T-RB	100	1.6	1.1	One End Sealed	10

## W Band Standard EPR Tubes

In the mid 1990's, the first commercial W-band EPR spectrometer was produced, initiating the expansion of W-band EPR techniques into both academic and industry laboratories. Wilma-LabGlass adopts synthetic quartz with lowest impurities to guarantee success in detecting subtle spectroscopic details.

### Suprasil

Product No.	Length (mm)	O.D. (mm)	I.D. (mm)	Ends	Package Qty.
WG-213ST9S	40	0.9	0.5	Both Ends Open	10
WG-213ST9S-RB	40	0.9	0.5	One End Sealed	10

## Tube Caps

Wilmad-LabGlass offers two grades of tube cap, disposable and precision. Disposable NMR tube caps are made from Polyethylene or Ethylene Vinyl Acetate depending on the tube O.D.



### Disposable Caps

Product No.	Fits Tube O.D. (mm)	Material	Color	Package Qty.
521-R	1.7	Polyethylene	Red	25
521-T	2.0	Polyethylene	Red	25
521-U	2.5	Polyethylene	Red	25
521-P-100	3.0	Polyethylene	Red	100
521-G-100	4.0	Polyethylene	Blue	100
521-GRN-100	5.0	Ethylene Vinyl Acetate	Green	100
521-ORG-100	5.0	Ethylene Vinyl Acetate	Orange	100
521-B-100	8.0	Polyethylene	Neutral	100
521-C-100	10.0	Polyethylene	Red	100

### Precision Caps

- Wilmad-LabGlass's Precision Caps are machined to exact specifications for better sealing.
- Polyethylene Caps are ideal for experiments that require an air-tight environment under vacuum or low pressure less than 1 bar.
- 7389/35 Gum Synthetic Isoprene Caps allow easy access via syringe needle.
- These caps only fit our Precision brand tubes



Product No.	Fits Tube with O.D. (mm)	Material	Color	Package Qty.
WG-1264-3	3.0	PTFE	White	25
WG-1264-4	4.0	PTFE	White	25
WG-1264-5	5.0	PTFE	White	25
WG-1264-8	8.0	PTFE	White	25
WG-1264-10	10.0	PTFE	White	25
521-PC-100	5.0	Polyethylene	Transparent	100
521-PC-1000	5.0	Polyethylene	Transparent	1000
521-S-100	5.0	7389/35 Gum	Neutral	100
521-S-1000	5.0	7389/35 Gum	Neutral	1000

# Gas-Tight Tubes

## Graded Seal EPR Tube

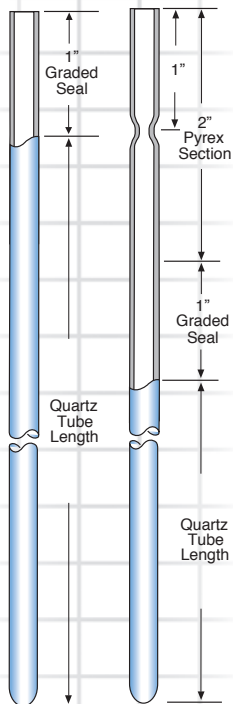

EPR tubes with graded seal are ideal for fusing EPR tube to existing valve, glass taper and socket joint. The top of the graded seal is made of Pyrex glass with relatively low melting point compared to quartz.

### Clear Fused Quartz

Product No.	Quartz tube Length (mm)	O.D. (mm)	I.D. (mm)
707-GRD-203M	178	4.0	3.0
707-GRD-275M	250	4.0	3.0
710-GRD-203M	178	5.0	4.0
710-GRD-275M	250	5.0	4.0

## Constricted Vacuum Tube and Tip-Off Manifolds

Constricted EPR tubes offer a convenient way to flame-seal air-sensitive samples, the only reliable container for long-term storage in liquid nitrogen tanks. Simply apply vacuum to the tube using our Tip-Off Manifold, then heat the constricted portion and twist off to seal the sample in tube. Due to the high melting point of quartz, a graded seal is fused on top of the tubing. Other configurations, such as different O.D., length, position of the constriction, can be manufactured. Please contact us for price quote.

### Clear Fused Quartz

Product No.	Quartz tube Length (mm)	O.D. (mm)	I.D. (mm)
707-GRD-100MCONS	100	4.0	3.0

Left: Graded Seal EPR Tube  
Right: Constricted Vacuum Tube

## Tip-Off Manifolds

Chemical resistance of the manifold ports is excellent. The EPR tube will connect to a threaded aluminum bushing which is isolated from the vacuum by a Teflon high vacuum rotary valve with Viton O-rings. Rotating the valve will open and close the tube to the vacuum line.

### General Components

Product No.	Description
552-P	Piston Valve
552-S	Piston O-Ring
552-G	Glass Section

### Tip-Off Manifold for 4 mm O.D. Tubes

Product No.	Description	Fits Tube with O.D. (mm)
552-4	Complete Tip-off Manifold	4.0
552-4-B	Aluminum Port Bushing	4.0
552-4-O	O-Ring, Viton	4.0



1: Glass Section; 2: Piston O-ring; 3: Piston Valve; 4: Aluminum Port Bushing

**NOTE 1:** Wilmad-LabGlass also offers Tip-Off Manifold for 3 mm O.D. and 10 mm O.D. tubes. Please contact us for pricing.



## Low Pressure/Vacuum Tube

Wilmad-LabGlass provides a novel low pressure/vacuum (LPV) tube for both NMR and EPR experiments. A redesigned sealing surface eliminates leaks and greatly increases its lifetime when compared to traditional gas-tight tubes. Our low pressure/vacuum tube continues to offer a convenient flame-free sealing solution for air sensitive or volatile liquid samples at any pressure from vacuum to pressure slightly above 1 bar.

- 4X larger sealing surface increases lifetime and reliability.
- PTFE piston provides a 100% contamination-free seal.
- Axial symmetric design guarantees its application in spinning experiments.
- Spare glass tube can be purchased separately.
- Cheaper price reduces experimental costs.
- Can hold vacuum up to  $10^{-6}$  torr.

### Suprasil

Product No.	O.D. (mm)	I.D. (mm)	Bottom Tube Length (inch)
734-LPV-7	4.000±0.013	3.200±0.013	8
722-LPV-7	4.970±0.013	4.200±0.013	8
733-3LPV-7	10.000±0.013	9.100±0.013	8

### Spare Parts for LPV Tube

Product No.	Description
GVA-5	Pyrex Adapter
GVA-5-1420	Pyrex Adapter with 14/20 Outer Joint
LPV-O-5	Replacement O-ring for LPV(5Pkg.)
WNMR/5-PISTON	PTFE Piston for LPV Tube
X-LPV-X-T-SQ <sup>1</sup>	Spare Tube Only with Glass Screw

**Note 1:** For spare tube orders, the original LPV part number must be provided, for example 734-LPV-7, as "X", which denotes the style (734) and length (7"). Price varies on O.D. and length.



## Screw-Cap Tube

The Screw Cap Tube is commonly used in sample degasification. It can maintain a vacuum quality of  $>10^{-4}$  torr. For better vacuum, please check our Pressure/Vacuum Tube (Page 9) and Quick Pressure Valve Tube (Page 8).

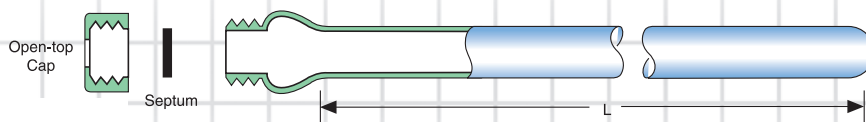

Each Screw-Cap Tube comes with one PTFE/Silicone septum and one open cap. PTFE/rubber septum and solid cap are available to purchase separately.

### Resonance Report

Due to the nature of glass, Extreme Caution should be exercised at elevated or reduced pressures since a tiny scratch on the glass surface would significantly lower the tensile strength. Adequate safety shielding should always be used when working in these conditions. Request a copy of technical report NMR-003:Pressure Performance of NMR and EPR Sample Tubes at [www.wilmad-labglass.com](http://www.wilmad-labglass.com) under service/support.

### Screw-Cap EPR Sample Tubes

#### Clear Fused Quartz

Product No.	O.D. (mm)	I.D. (mm)	Bottom Tube Length (inch)
707-TR-7	4.0	3.0	8

#### Suprasil

Product No.	O.D. (mm)	I.D. (mm)	Bottom Tube Length (inch)
734-TR-7	4.0	3.2	8
722-TR-7	5.0	4.2	8
733-3TR-7	10.0	9.1	8

### Screw-Cap Accessories

Product No.	Description	Fits Tube with O.D. (mm)	Qty. per Package
TR-LR-01	PTFE/rubber <sup>1</sup>	4 and 5	36
TR-LR-05	PTFE/rubber <sup>1</sup>	10	36
TR-LS-01	PTFE/silicone <sup>2</sup>	4 and 5	36
TR-LS-05	PTFE/silicone <sup>2</sup>	10	36
TR-SC-01	Solid Cap	4 and 5	12
TR-SC-05	Solid Cap	10	12
TR-OC-01	Open Cap	4 and 5	12
TR-OC-05	Open Cap	10	12

**Note 1: PTFE/Rubber** Septum is a laminated disc consisting of a sheath of PTFE, which is bonded chemically to pharmaceutical rubber. This septum is inert to most solvents and many corrosive materials but not recommended for multiple punctures.

**Note 2: PTFE/Silicone** Septum is a laminated disc consisting of a sheath of PTFE, which is bonded chemically to silicone. This type of septum is inert to most organic solvents and compounds but poor to strongly corrosive materials. Remains reliable after multiple punctures.

### Quick Pressure Valve Tube

Wilma-LabGlass's Quick Pressure Valve Sample Tubes are specially designed to simplify the work of EPR studies for catalysis, gas-liquid phase reactions, air sensitive samples and elevated temperature studies using low boiling point solvents.

#### Features:

- Easy to operate - one turn to open, one to close.
- Larger opening for convenient sample addition.
- Lightweight, concentric design for better performance.
- Offered with Wilma-LabGlass Precision Tubes - thin, medium and heavy wall.
- Choice of Viton or Kalrez O-ring for different applications.
- Adapters available to both 1/16" and 1/8" tubing.

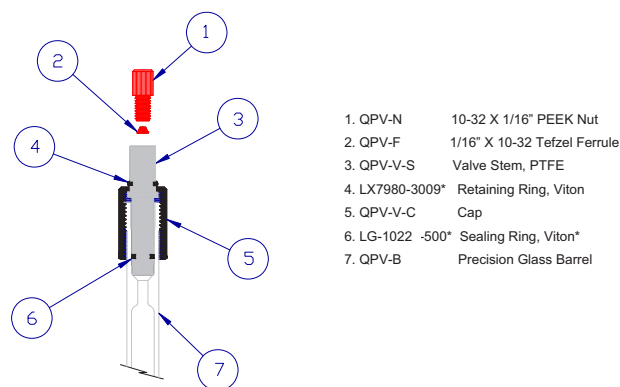

1. QPV-N 10-32 X 1/16" PEEK Nut
2. QPV-F 1/16" X 10-32 Tefzel Ferrule
3. QPV-V-S Valve Stem, PTFE
4. LX7980-3009\* Retaining Ring, Viton
5. QPV-V-C Cap
6. LG-1022 -500\* Sealing Ring, Viton\*
7. QPV-B Precision Glass Barrel

#### Basic Tubing Connection

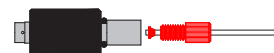

Slide the Nut (1) and Ferrule (2) onto the 1/16" diameter tubing. Make sure the end of the tubing extends past the end of the ferrule as shown. Screw the assembly into the threaded port in the end of the valve stem until it's finger tight.

### Quick Pressure Valve (QPV) Tubes (Parts for Basic Tubing Connection Included)

#### Suprasil

Product No.	O.D. (mm)	I.D. (mm)	Bottom Tube Length (inch)	Wall Thickness (mm)	Recommended Max Pressure (psi)
734-QPV-7	4.000±0.013	3.200±0.013	8	0.40	200
722-QPV-7	4.970±0.013	4.200±0.013	8	0.38	200
721-QPV-7	4.970±0.013	3.430±0.013	8	0.77	300
733-3QPV-7	10.000±0.013	9.100±0.013	8	0.45	150

#### T Resonance Report

Due to the nature of glass, Extreme Caution should be exercised at elevated or reduced pressures since a tiny scratch on the glass surface would significantly lower the tensile strength. Adequate safety shielding should always be used when working in these conditions. Request a copy of technical report NMR-003: Pressure Performance of NMR and EPR Sample Tubes at [www.wilma-labglass.com](http://www.wilma-labglass.com) under service/support.

## Spare Parts and Optional O-Rings

Product No.	Description
QPV-V	Valve plug assembly with nut and ferrule
QPV-VOS	Set of 20 Viton O-Rings - Viton Sealing O-Ring and Viton cap retaining ring, pack
QPV-KOS	Kalrez sealing O-Ring and Viton cap retaining ring, chemically resistant and highly inert

## Optional Tubing Connections

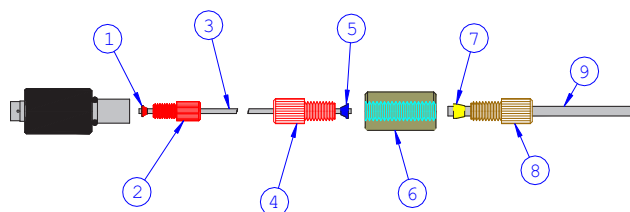

- |                |   |
|----------------|---|
| 1. QPV-F       | Ferrule for 10-32 nut / 1/16" O.D. Tubing (Supplied with QPV-V Valve) |
| 2. QPV-N       | Nut, 10-32 for 1/16" O.D. Tubing (Supplied with QPV-V Valve)          |
| 3. QPV-T16     | Tubing, 1/16" O.D. PTFE   |
| 4. QPV-N14     | Nut, 1/4-28 for 1/16" Tubing  |
| 5. QPV-F14     | Ferrule for 1/4-28 nut / 1/16" Tubing                                 |
| 6. QPV-U14     | Union, 1/4-28   |
| 7. BP-1822-018 | Ferrule for 1/4-28 Nut / 1/8" Tubing                                  |
| 8. BP-1821-018 | Nut, 1/4-28 for 1/8" O.D. Tubing                                      |
| 9. BP-1823-014 | Tubing, 1/8" O.D. PTFE  |

## Ferrules, Nuts, Tubing and Unions for QPV Sample Tube

Product No.	Description	Qty. per Package
QVP-F14	Ferrule, 1/16", ETFE, Blue - to attach vacuum/pressure source	10
QVP-N14	Nut, 1/16", 1/4-28, Delrin, Red - to attach vacuum/pressure source	1
QVP-T16	Tubing, PTFE, 1/16" O.D. X 3 FT.	1
QVP-U14	Union, Delrin, 1/4-28 for 1/8" tubing	1
QPV-F	Ferrule, 1/16" x 10-32	10
QPV-N	Nut, 1/16" 10-32 x 1/16"	1
OF-60	Vacuum Connector	1
BP-1821-018	Nut 1/4-28 for 1/8" tubing	1
BP-1822-018	Ferrule 1/4-28 for 1/8" tubing	1
BP-1823-018	Tubing 1/8" x 10 feet	1

## Pressure/Vacuum Sample Tube

Wilmad's Pressure/Vacuum Tube is the most reliable EPR tube for (1) medium range pressure (~300 psi), and (2) ultra vacuum below  $10^{-6}$  torr experiments. It is designed to connect to a 1/8" metal (stainless steel or brass) vacuum line using SwageLok fittings or a rubber vacuum hose using a glass connector (OF-60). The PV-ANV valve is made of Teflon and all other parts are made of Pyrex or equivalent glass. Valve is opened simply by turning counterclockwise.

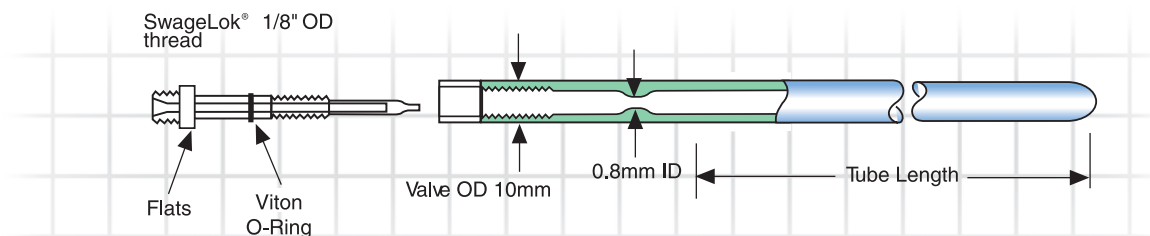

Each Pressure/Vacuum tube is supplied with a PV-ANV valve, but not with a Swagelok® nut or ferrules. Order these separately (see spare parts/ adapter table).

### T Resonance Report

Due to the nature of glass, Extreme Caution should be exercised at elevated or reduced pressures since a tiny scratch on the glass surface would significantly lower the tensile strength. Adequate safety shielding should always be used when working in these conditions. Request a copy of technical report NMR-003: Pressure Performance of NMR and EPR Sample Tubes at [www.wilmad-labglass.com](http://www.wilmad-labglass.com) under service/support.

## Connections

The upper portion of the Needle Valve is threaded and I.D. beveled to accept Swagelok 1/8" tubing nut and ferrule, which makes it simple to connect the "PV" tubes to a compressed gas cylinder or directly to a vacuum rack as shown on the right picture. The needle valve could be tightly closed using a small wrench (flat surfaces are provided on the valve). Components of the Pressure Valve EPR Tube and compatible fittings are available separately. See spare parts/adapters. Tube available in 7 and 8 lengths. Order shortest length to minimize overall weight.

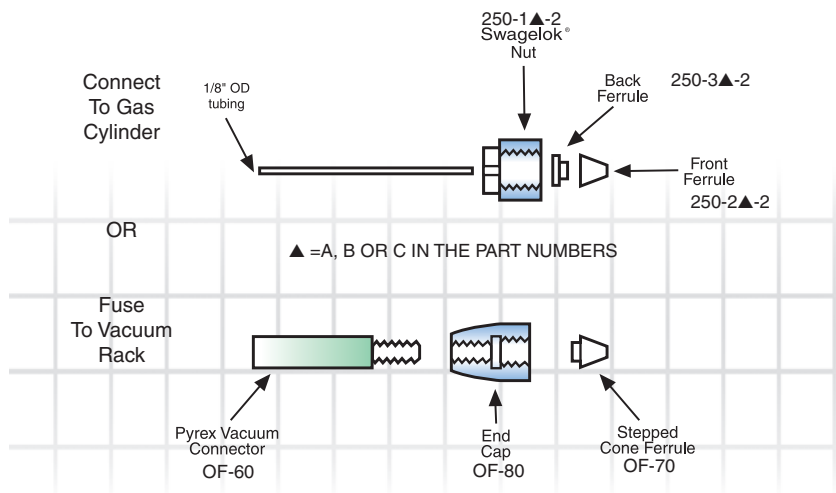

**Pressure/Vacuum Sample Tube (Including one glass tube and one PV-ANV Valve)**

## Suprasil

Product No.	O.D. (mm)	I.D. (mm)	Bottom Tube Length (inch)	Wall Thickness (mm)	Recommended Max Pressure (psi)
734-PV-7	4.000±0.013	3.200±0.013	8	0.40	200
722-PV-7	4.970±0.013	4.200±0.013	8	0.38	200
721-PV-7	4.970±0.013	3.430±0.013	8	0.77	300
700-QPV-7	4.970±0.013	2.160±0.013	8	1.40	400
733-3PV-7	10.000±0.013	9.100±0.013	8	0.45	150

## Connectors for Pressure/Vacuum Sample Tube

Product No.	Description	Material	Qty. per Package
250-1A-2 250-1B-2 250-1C-2	Swagelok Nut for 1/8" OD Tubing	Brass Stainless Steel PTFE	6
250-2A-2 250-2B-2 250-2C-2	Front Ferrule for 1/8" OD Tubing	Brass Stainless Steel PTFE	10
250-3A-2 250-3B-2 250-3C-2	Back Ferrule for 1/8" OD Tubing	Brass Stainless Steel PTFE	10
250-4A-2 250-4B-2	Brass Swagelok Male Connector for 1/8" tubing	Brass Stainless Steel	1
OF-60	Pyrex Vacuum Connector	Borosilicate Glass	1
OF-80	End Cap	Polypropylene	1
OF-70	Stepped Cone Ferrule	PTFE	4
PV-ANV	Replacement Valve	PTFE	1
PV-ANV-O	Replacement O-Ring for PV-ANV Valve	Viton	1

### **T** Resonance Report

Due to the nature of glass, Extreme Caution should be exercised at elevated or reduced pressures since a tiny scratch on the glass surface would significantly lower the tensile strength. Adequate safety shielding should always be used when working in these conditions. Request a copy of technical report NMR-003: Pressure Performance of NMR and EPR Sample Tubes at [www.wilmad-labglass.com](http://www.wilmad-labglass.com) under service/support.

## Omni-Fit EPR Tubes

Wilmad-LabGlass's Omni-Fit EPR Tubes are designed for easy injection of chemicals through a gas-tight syringe without using a glove box for air-sensitive samples.

The Omni-Fit Tube consists of a standard tube topped by a sturdy 2" section of medium-walled tubing which supports the valve system.

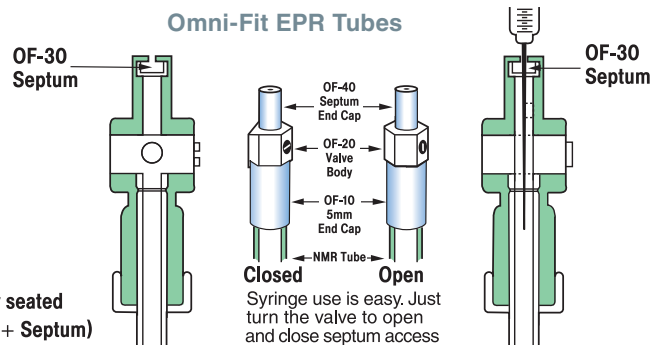
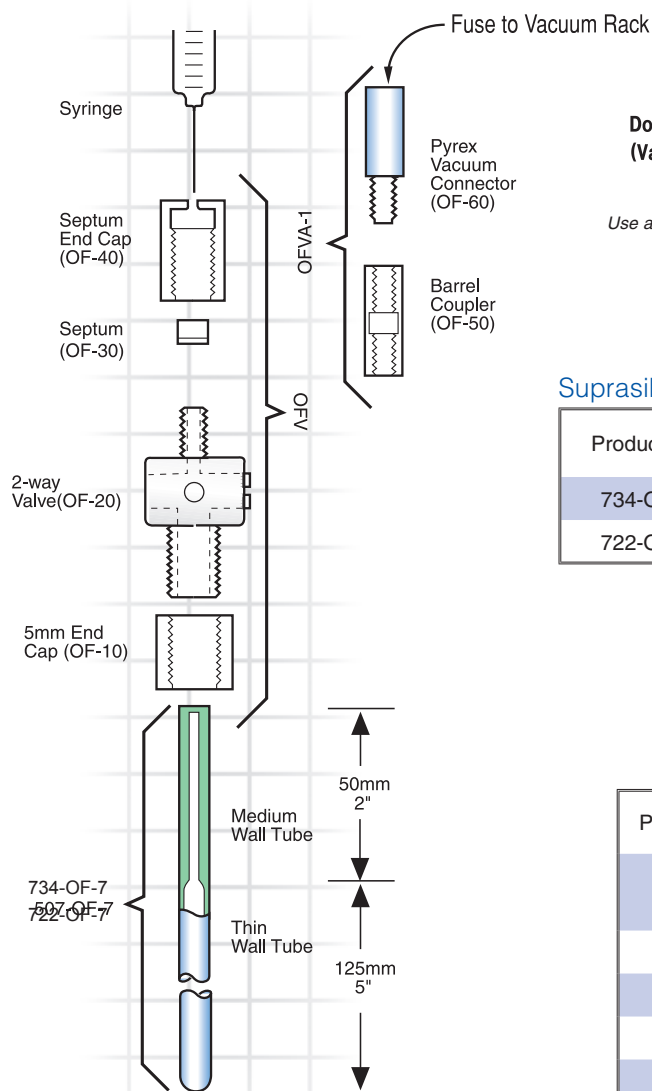

Use a small flat-head screwdriver to open and close the valve by rotating the screw-head 90°.

### Omni-Fit Sample Tubes Only

#### Suprasil

Product No.	O.D. (mm)	I.D. (mm)	Bottom Tube Length (inch)
734-OF-7	4.000±0.013	3.200±0.013	8
722-OF-7	4.970±0.013	4.200±0.013	8

### Valve and Spare Parts for Omni-Fit Sample Tubes

Product No.	Description	O.D. (mm)
OFV	Omni-Fit Valve System with Complete Accessories	5
OF-10	Omni-Fit 5mm End Cap	5
OF-20	Omni-Fit 2-way Valve	5
OF-30	Omni-Fit Septum (pkg/6)	5
OF-40	Omni-Fit Septum Cap	5
OF-50	Omni-Fit Barrel Coupler	5
OF-60	Omni-Fit Vacuum Connector	5
OFVA-1	Omni-Fit Adapter Set	5

#### **T** Resonance Report

Due to the nature of glass, Extreme Caution should be exercised at elevated or reduced pressures since a tiny scratch on the glass surface would significantly lower the tensile strength. Adequate safety shielding should always be used when working in these conditions. Request a copy of technical report NMR-003: Pressure Performance of NMR and EPR Sample Tubes at [www.wilmad-labglass.com](http://www.wilmad-labglass.com) under service/support.



## Wilmad-LabGlass Select-A-Product Guide for Gas-Tight Tubes

Use Universal Solvent Jet Tube Washer WG-7200-2(J2) on Page 14 to wash Low Pressure/Vacuum Tube and Screw-Cap NMR Tubes, and WG-7200-1(J1) for Quick Pressure Valve Tube and Omni-Fit NMR Tubes.  
Use Hamilton Syringe 81420 plus PTFE Needle 90630 on Page 18 to wash Pressure/Vacuum Tube.

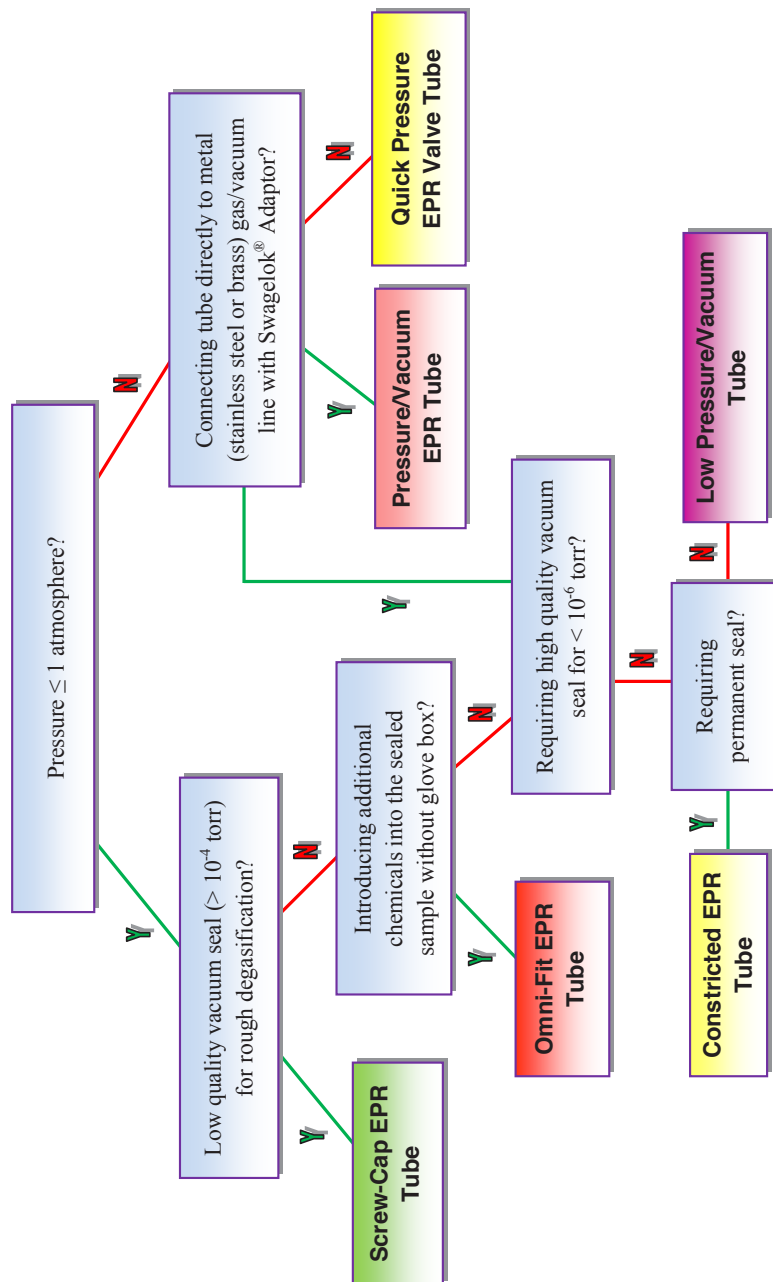

Note 1: Please check the maximum pressure for Quick Pressure Valve Tube and Pressure/Vacuum Tube.

Note 2: For any experiment with NH<sub>3</sub> gas or other corrosive gas we recommend Quick Pressure Valve Tube with Kalrez O-ring

**T Resonance Report**

Due to the nature of glass, Extreme Caution should be exercised at elevated or reduced pressures since a tiny scratch on the glass surface would significantly lower the tensile strength. Adequate safety shielding should always be used when working in these conditions. Request a copy of technical report NMR-003: Pressure Performance of NMR and EPR Sample Tubes at [www.wilmad-labglass.com](http://www.wilmad-labglass.com) under service/support.

## EPR Reference Standard

These irradiated fused quartz rods are useful for monitoring performance of pulsed EPR spectrometers, both as a function of time to ensure continued good performance, and for interlaboratory comparisons<sup>1,2</sup>. The 100 mm long, 4 mm O.D. and 1.6 mm O.D. fused quartz rods were irradiated by NIST to a dose of 261 Gy with <sup>60</sup>Co gamma. Defect levels were chosen to give X-band S/N in a useful range for single spin echoes. The dimensions are selected to fit Bruker FlexLine X-band and Q-band EPR resonators, but they can be used with other resonators for quality tests.

### X Band Reference Standard for Pulsed EPR

**Figure on the right:** X-band field-swept echo of a 261 Gy irradiated quartz sample obtained using Bruker E580 with  $\tau/2=40$  ns @ 22 dB power,  $d_1=1000$  ns,  $d_x=400$  ns, SRT=2 ms, Q~425, and 20 MHz bandwidth.

Product No.	O.D. (mm)	Length (mm)
WG-R-E01	4.00	100

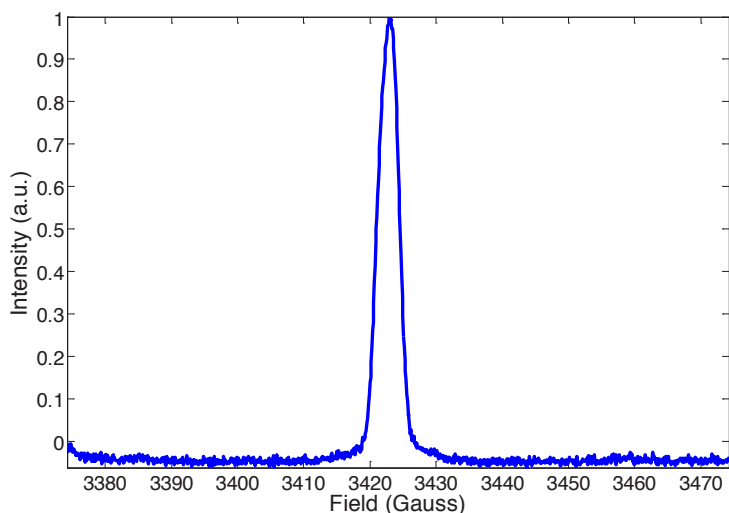

### Q Band Reference Standard for Pulsed EPR

**Figure on the right:** Q-band field-swept echo of a 261 Gy irradiated quartz sample obtained using Bruker E580 with  $\tau/2=40$  ns @ 4 dB power,  $d_1=1000$  ns,  $d_x=400$  ns, SRT=2 ms, Q~650,  $d_1=1000$  and 20 MHz bandwidth.

Product No.	O.D. (mm)	Length (mm)
WG-R-E02	1.60	100

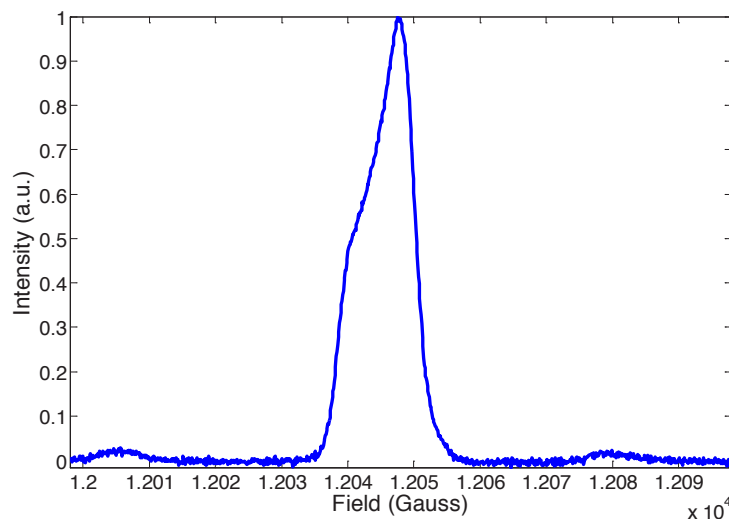

1: Irradiated Fused Quartz Standard Sample for Time Domain EPR, S. S. Eaton and G. R. Eaton, J. Magn. Reson. A102, 354-356 (1993).

2: A Signal-to-Noise Standard for Pulsed EPR, G. R. Eaton, S. S. Eaton, R. W. Quine, D. Mitchell, V. Kathirvelu, and R. T. Weber, J. Magn. Reson. 205, 109-113 (2010).

## EPR Accessories

### Tube Washers

#### Universal Solvent Jet Tube Washer

Wilma-LabGlass's Universal Solvent Jet Washer can be used for any length sample tube by a simple adjustment of the flexible PTFE tubing. It is especially recommended for cleaning our gas-tight sample tubes.

By loosening and retightening the tubing fitting on the assembled washer head, the PTFE tubing that extends into the sample tube is adjusted to the proper length. The washer head is then affixed to a filter flask (with sidearm) and the side tubing is inserted into a washing solvent reservoir. After an inverted sample tube is placed over the PTFE tubing, a vacuum is applied to the flask and the sample tube is pressed against the rubber gasket to form an air-tight seal that starts the solvent flow. By lifting the PTFE tubing out of the solvent reservoir, the sample tube can be air-dried.



Product No.	Fits Tubes with O.D. (mm)	Washer Connection
WG-7200-1	2.5-5 mm	Plain
WG-7200-2	6.5-25 mm	Plain
WG-7200-J1	2.5-5 mm	§24/40 Joint
WG-7200-J2	6.5-25 mm	§24/40 Joint

#### Parts for Universal Solvent Jet Washer

Product No.	Description	For Tube Washers
WG-7200-B	Washer Glass Body	WG-7200-1, -2
WG-7200-J-B	Washer Glass Body	WG-7200-J-1, -J-2
WG-7200-S-G	Rubber Gasket "G"	WG-7200-1, J1
WG-7200-L-G	Rubber Gasket "G"	WG-7200-2, J2
WG-7200-S-O	Small O-Ring "O"	WG-7200-1, J1
WG-7200-L-O	Small O-Ring "O"	WG-7200-2, J2
WG-7200-S-P	PTFE Tubing "T"	WG-7200-1, J1
WG-7200-L-P	PTFE Tubing "T"	WG-7200-2, J2



#### Filter Flasks with Vacuum Sidearms

Filter flasks have a standard taper § 24/40 outer joint and are used with WG-7200 Universal Tube Washer.

Product No.	Description	Volume (mL)
LG-7800-102	Filter Flask with Vacuum Sidearm	250
LG-7800-104	Filter Flask with Vacuum Sidearm	500
LG-7800-106	Filter Flask with Vacuum Sidearm	1000

## Ultrasonic Cleaning Systems

The Ultrasonic Cleaning Systems can wash up to 20 tubes at a time and are recommended for NMR and EPR research facilities. Operating at 21,000 sonic vibrations per second, these versatile, compact units can be used with aqueous detergent solutions or organic solvents (tank manufactured from stainless steel, 1 gallon capacity). Tube Cleaning Rack is plastic-coated to protect tubes. Available in a number of configurations, e.g. with 0-30 min timer and/or heater (thermostated for 60°C) these units provide up to 100 watts output while drawing a maximum of just 1 A input power.

**Capacity:** 1 gallon (approximately 3.8 liters)  
**Tank Dimensions:** 9" x 5" x 6" deep  
**Outer Dimensions:** 10 1/2" x 6 1/2" x 11" high



### Ultrasonic Cleaning System Body<sup>1</sup>

Product No.	Description	Voltage (V)
SC-101	Ultrasonic Cleaner	110/120
SC-101T	Ultrasonic Cleaner with 0-30 Minute Timer	110/120
SC-101H	Ultrasonic Cleaner with Heater	110/120
SC-101TH	Ultrasonic Cleaner with 0-30 Minute Timer and Heater	110/120

Note 1: Stainless steel trays, baskets, lid and rack are **ordered separately**.

### Accessories

Product No.	Description
C-100	Cover, Stainless Steel
B-101	Basket, Stainless Steel
IT-101	Liquid Tight Stainless Steel Tray
WG-11100	Poly Coated NMR Tube Rack

### Detergent

Product No.	Description
101-GAL	1 Gallon Alkaline Cleaning Concentrate

## EPR Tube Racks

Wilma-LabGlass carries three different tube racks.

- 820-A For large numbers of tubes, our lightweight polypropylene tube racks maximize your benchtop storage capacity and are virtually inert.
- WG-1301 coated stainless steel rack is completely encased in inert PVC to prevent scratches to the tube.
- WG-2442 is an uncoated stainless steel rack.

Product No.	Material	Fits Tube with Maximum O.D. (mm)	Capacity (Max number of tubes)
820-A	Polypropylene	5	72
WG-1301	PVC-coated Steel	12	30
WG-2442	Stainless Steel	5	12

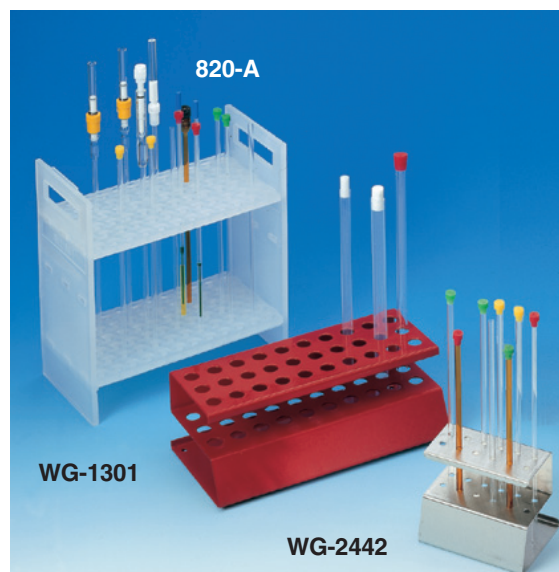

## Liquid Nitrogen Dewar Flask



Liquid nitrogen is an easily transported and economic source of coolant whose boiling point is far below the freezing point of water without pressurization. This unique feature makes liquid nitrogen extremely useful for a wide range of applications in basic science research, such as cell cryopreservation, sample degasification by freeze-pump-thaw cycle and cold trap for experiments involving vacuum lines.

Wilmad-LabGlass, the world's leading provider in NMR/EPR consumables and accessories, offers a high quality Liquid Nitrogen Dewar Flask to meet these applications.

### Features:

- 30% cheaper than other manufacturers' similar products.
- Unique metal base increases stability.
- High vacuum ( $<10^{-7}$  torr) jacket minimizes liquid nitrogen loss during storage.

Product No.	Base	I.D. (mm)	Total Height (mm)	Inside Depth (mm)	Max Volume (mL)	Comparable to
LN2DF-600-1	3 inch Aluminum	80	180	150	600	Pope Scientific 8640

## Combination pH Electrode

For use in 4 and 5 mm thin-walled Precision sample tubes up to 8" in length. Glass probe dimensions are 3 mm O.D. x 180 mm length.

**pH Range:** 0-14      **Resolution:** 0.02 pH Units      **Resistance at 20°C:** 100-1000 MΩ  
**Temperature Range:** 0-70°C      **Sodium Error:** 0.1 at pH 12      **Reproducibility:** 99% within



Connectors

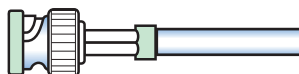

6030-02-BNC



6030-02-6

### pH Electrode<sup>1</sup>

Product No.	Description	Price Each
6030-02-BNC	pH Electrode with BNC Connector	\$459.27
6030-02-6	pH Electrode with 6 mm Radiometer Connector	\$431.87

### Electrode Solutions

Product No.	Description
18513	Reference Solution - 3M KCl saturated with AgCl (250 mL)
18823	Electrode Cleaner - remove protein (125 mL)
18528	Diaphragm Cleaner - Thiol based (250 mL)
18508	Electrode Storage Solution (125 mL)

Note 1: These electrodes are extremely fragile due to size. Please pay extra attention during operation.



## Pipettes



### Long-tip Pipettes

Product No.	Overall Length (inch)	Compatible with	Qty. per Package
803A	13-1/4	Min. 3 mm O.D. Max. 9 inch long tubes	100
803C	10-3/4	Min. 3 mm O.D. Max. 7 inch long tubes	100

### Short Pipette and Latex Bulb

Product No.	Compatible with	Qty. per Package
802	Short Pasteur Pipette	100
804	Latex Bulb (for all pipettes)	50

## Sample Filter

Sample sedimentation will bring trouble to homogeneity of the sample. Use Wilmad-LabGlass's special Bulb Filter to remove large particles. Two designs available: one with luer tip for stainless steel needle attachment, the other with glass tip. Both fit into Wilmad-LabGlass EPR tubes. The sintered glass tip removes particles larger than 60  $\mu\text{m}$ . 807 fits EPR tubes with I.D.  $\geq 3.2$  mm, which include thin-walled Precision Brand EPR tubes with O.D.  $\geq 4$  mm. 808 fits most of all EPR tubes with the needle attached.

Product No.	Description
807	Regular Tip Filter
808	Luer Tip Filter
809	Rubber Bulb
810-A	Needle, Stainless Steel, 3" long
810-B	Needle, Stainless Steel, 5" long
810-C	Needle, Stainless Steel, 8" Long

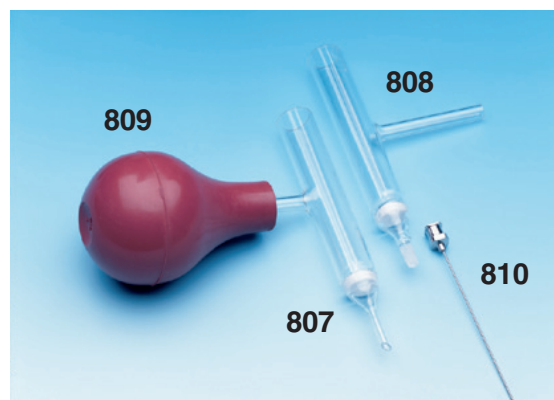

## Stainless Steel Micro-Spatula

Getting a tiny powder sample into any tube larger than 4 mm O.D. tube should never be a struggle again. Unlike ordinary spatulas, Wilmad-LabGlass's Stainless Steel Spatula fits into the most X band EPR tubes. Add or remove samples easily, (including freeze-dried); scoop samples with the round end or pry stiff samples with the sharp edged flat end.



Product No.	Material	Length (mm)
806	Stainless Steel	250

## Hamilton Gas-Tight Syringe (PTFE Luer Lock)



Wilmad-LabGlass offers PTFE Luer Lock syringes that best meet your sampling needs. These syringes handle air-sensitive and/or volatile samples with precise control over sample volumes.

**Features:**

- Gas and Liquid Tight.
- Reproducible (volumes to  $\pm 1\%$ ).
- Made of inert borosilicate glass, PTFE and stainless steel.
- Pressure tight to 200 psi.

Product No.	Syringe Max. Volume ( $\mu\text{L}$ )	Graduation Interval ( $\mu\text{L}$ )
81220	500	10
81320	1000	20
81420	2500	50

## Syringe Needles

The stainless steel needle is designed for septum punctures for air-sensitive sample. The PTFE version in various sizes offer a convenient way to load and wash your sample in capillary tubes.

Product No.	Material	O.D. (mm)	I.D. (mm)	Length (inch)	Qty./ Pkg.
91026	Stainless Steel	0.46	0.26	5	6
90052	Stainless Steel	0.71	0.41	5	6
90022	Stainless Steel	0.71	0.41	2	6
90630	PTFE	0.79	0.33	12	1
90628	PTFE	0.84	0.38	12	1
90626	PTFE	0.91	0.45	12	1
90624	PTFE	1.02	0.56	12	
90622	PTFE	1.14	0.69	12	
90620	PTFE	1.35	0.86	12	
90619	PTFE	1.57	0.97	12	
90618	PTFE	1.68	1.07	12	
90617	PTFE	1.80	1.19	12	
90616	PTFE	2.01	1.35	12	
90615	PTFE	2.11	1.50	12	



## Pressure Sensitive Tube Labels



Tired of writing on the tube to mark your samples? Try Wilmad-LabGlass's Pressure Sensitive Tube Labels.

Product No.	Qty./Pkg.
WGL-5	480

## Single Crystal Mounting Rod

These rods are manufactured with the highest grade of synthetic quartz to eliminate E' center defects and paramagnetic material contaminations; 2 sizes to choose from. Hexagonal rods are available upon request.

### Suprasil

Product No.	A (mm)	B (mm)	C (mm)	D (mm)
WG-856-Q	4.0	5.0	1.5	2.0
WG-857-Q	5.0	7.0	2.0	3.0

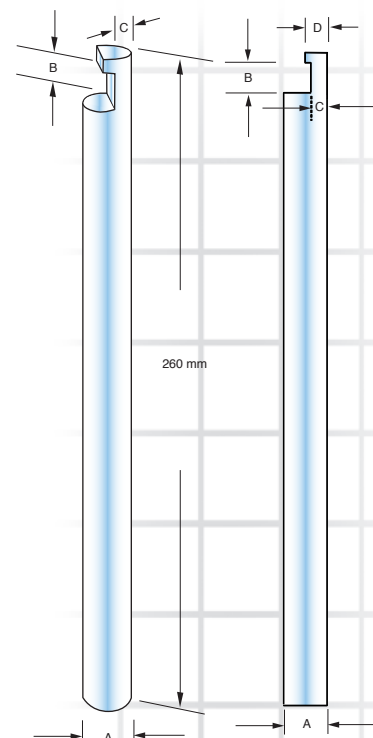

## X Band Aqueous Cells

### Standard TE<sub>102</sub> Cavity Aqueous Cells

When the sample contains water, the electric dipole moment of the water molecule interacts with the E field in the resonator and a large amount of microwave energy is absorbed by the sample. Flat cells confine the sample to a 0.3 mm space to solve this issue. The hexagonal stems are available. The sample volume is 150 µl for all cells.

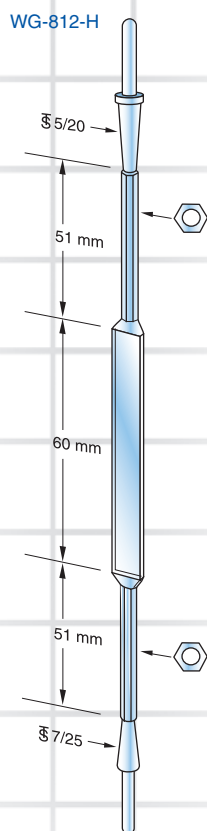

#### Round Stem

### Suprasil

Product No.	Flat Section Width/Length (mm)	Upper Tube I.D./O.D. (mm)	Lower Tube I.D./O.D. (mm)
WG-812-Q <sup>1</sup>	10.5/60	5/7	1.5-2.0/7-9
WG-812-S-Q	10.5/60	5/7	1.5-2.0/7-9
WG-814-Q <sup>1</sup>	10.5/60	0.5-1/5-7	0.5-1/5-7
WG-814-S-Q	10.5/60	0.5-1/5-7	0.5-1/5-7

#### Hexagonal Stem

### Suprasil

Product No.	Flat Section Width/Length (mm)	Upper Tube I.D./O.D. (mm)	Lower Tube I.D./O.D. (mm)
WG-812-H-Q <sup>1</sup>	10.5/60	5/7	1.5-2.0/7-9
WG-812-H-S-Q	10.5/60	5/7	1.5-2.0/7-9
WG-814-H-Q <sup>1</sup>	10.5/60	0.5-1/5-7	0.5-1/5-7
WG-814-H-S-Q	10.5/60	0.5-1/5-7	0.5-1/5-7

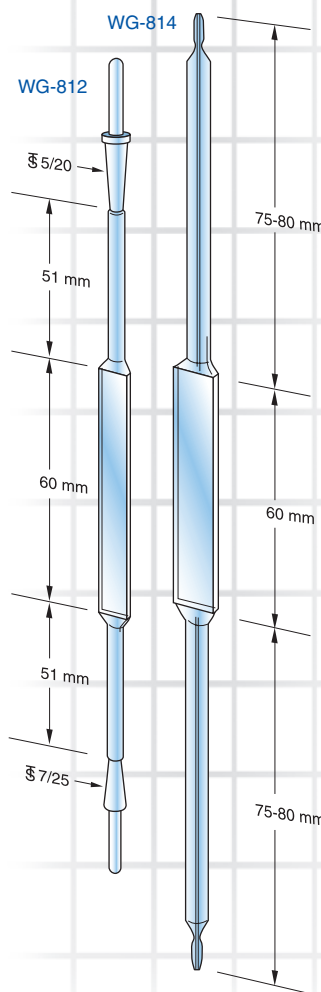

**Note 1:** Not recommended for experiments that require critical coupling due to the loose tolerance on center alignment compared to WG-812-S-Q and WG-814-S-Q.

## Standard TM<sub>110</sub> Cavity Aqueous Cells

These flat cells confine the sample to a 0.3 mm space. The sample volume is 275 µl for all.

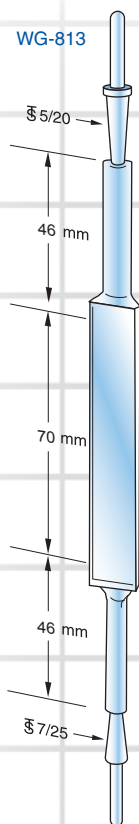

### Round Stem

#### Suprasil

Product No.	Flat Section Width/Length (mm)	Upper Tube I.D./O.D. (mm)	Lower Tube I.D./O.D. (mm)
WG-813-Q <sup>1</sup>	16.9/70	7/9	1.5-2.0/7-9
WG-813-S-Q	16.9/70	7/9	1.5-2.0/7-9
WG-813-A-Q <sup>1</sup>	16.9/70	7/9	1.0/7-9
WG-813-A-S-Q	16.9/70	7/9	1.0/7-9

### Hexagonal Stem

#### Suprasil

Product No.	Flat Section Width/Length (mm)	Upper Tube I.D./O.D. (mm)	Lower Tube I.D./O.D. (mm)
WG-813-H-Q <sup>1</sup>	16.9/70	7/9	1.5-2.0/7-9
WG-813-H-S-Q	16.9/70	7/9	1.5-2.0/7-9
WG-813-A-H-Q <sup>1</sup>	16.9/70	7/9	1.0/7-9
WG-813-A-H-S-Q	16.9/70	7/9	1.0/7-9

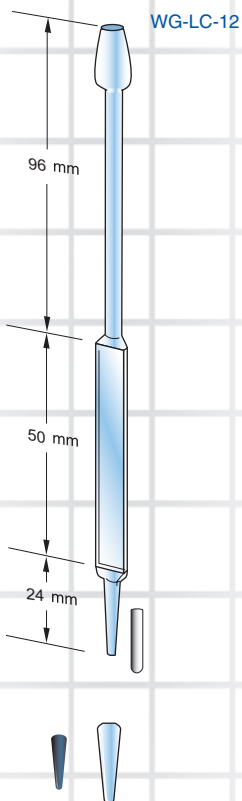
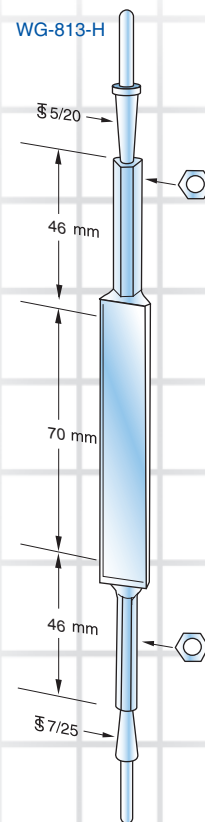

## JEOL Cell

These flat cells are optimized for JEOL's TE<sub>011</sub> cavities. Cells are compatible with original collet.

#### Suprasil

Product No.	Flat Section Width/Length (mm)	Upper Tube I.D./O.D. (mm)	Sample Volume (µl)
WG-LC-11	5/50	2/4	70
WG-LC-12	10/50	2/4	130

## Stoppers

Product No.	Material	Taper Joint
WG-813-STP-A	Hollow/Pyrex	7/25
WG-808-STP-A	Solid Quartz	7/25
WG-813-TMS-STP-A	Solid Quartz	5/20
WG-813-TMS-STP-B	Silicone	7/25
WG-812-SIL-STP	Silicone	3/7

Stoppers

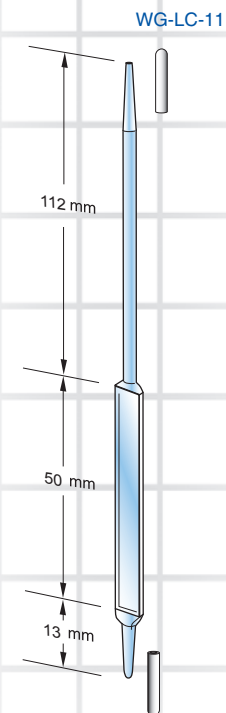

**Note 1:** Not recommended for experiments that require critical coupling due to loose tolerance on center alignment compared to -S versions.

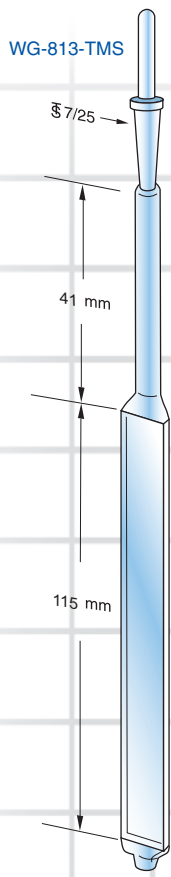

## Small Volume VT TE<sub>102</sub> Cavity Aqueous Cells

Flat cells confine the sample to a 0.5 mm space. The size of the flat section fits into standard TE<sub>102</sub> VT dewar insert on page 23.

### Suprasil

Product No.	Flat Section Width/Length (mm)	Upper Tube I.D./O.D. (mm)	Sample Volume (μl)
WG-808-Q <sup>1</sup>	4.75/47	3/4	100
WG-808-S-Q	4.75/47	3/4	150

## Large Volume VT TM<sub>110</sub> Cavity Aqueous Cells

Designed to use with TM<sub>110</sub> VT dewar insert WG-821-TMR-Q (page 24) for variable temperature studies.

### Suprasil

Product No.	Flat Section Width/Length (mm)	Upper Tube I.D./O.D. (mm)	Sample Volume (μl)
WG-813-TMS-Q <sup>1</sup>	13/115	4/6	430
WG-813-TMS-S-Q	13/115	4/6	430

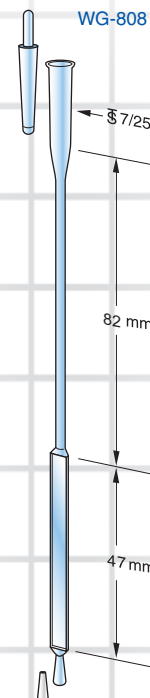

## Tissue Sample Cells

EPR Tissue Sample Cells are used for viscous samples such as polymers and wet tissue. All cells, except WG-807-Q, include a 0.5 mm deep well for thick samples. The sample is placed between the plates. EPR Tissue Sample Cells come with two support rods. Each cell includes two coverslides and two "Bronzite" clips. Optional TPX plastic is highly permeable to O<sub>2</sub>, N<sub>2</sub> and CO<sub>2</sub> and should not be used with organic solvents.

### Suprasil

Product No.	Rod Length Upper(A)/Lower(B) (mm)	Cavity (D) Width/Length (mm)	Baseplate (C) Width/Length (mm)	Coverplate Width/Length (mm)
WG-806-Q	70/70	5/10	8/51	8/42
WG-806-A-Q	70/70	7/23	10/51	10/42
WG-806-B-Q	90/63	7/23	16/65	10/42
WG-807-Q	70/70	none	8/51	8/42

### Cover Plates

Product No.	Material	Length/Width (mm)	Compatibility
WG-806-CP-Q	Suprasil	42/8	WG-806-Q WG-807-Q
WG-806-TPX	TPX	42/8	WG-806-Q WG-807-Q
WG-806-A-CP-Q	Suprasil	42/10	WG-806-A-Q
WG-806-A-TPX	TPX	42/10	WG-806-A-Q
WG-806-B-CP-Q	Suprasil	56/16	WG-806-B-Q
WG-806-B-TPX	TPX	56/16	WG-806-B-Q

### Clips

Product No.	Material	Compatibility
WG-806-CL	Bronzite	Universal

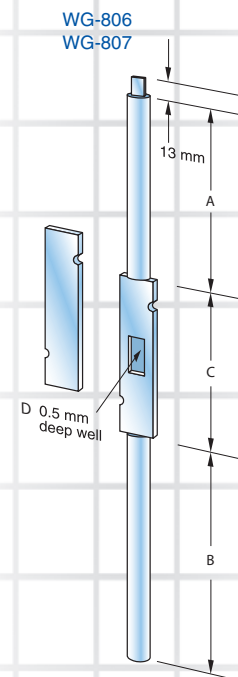
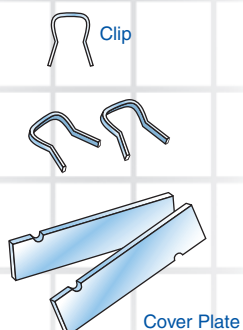

**Note 1:** Not recommended for experiments that require critical coupling due to loose tolerance on center alignment compared to -S versions.



Continuous flow is a powerful tool to study free radical intermediates with short life-time at steady state. Wilmad-LabGlass manufactures two types of flow cells: room and variable temperature for such applications. The length of the flow tube is 130 mm before reaching the mixing chamber, dead volume is less than 9.5  $\mu\text{L}$ , which corresponds to 2 ms dead time at 5 ml/sec flow rate. Inlet and outlet ports could be connected to 1/8" or 1/4" Tygon tubing depending on the size of the ports. Please contact us for flow cells for stop-flow studies with HPLC fitting. Rinse the cell thoroughly after each usage to prevent clogging.

### Room Temperature Flow Cells

WG-804-Q fits most Bruker TE<sub>102</sub> and JEOL TE<sub>011</sub> cavities. The sample thickness is 0.25 mm in the flat section.

Suprasil

Product No.	Sample Volume ( $\mu\text{L}$ )
WG-804-Q	125

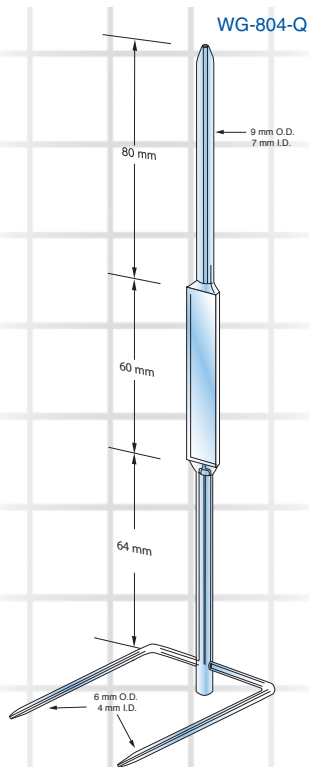

### Variable Temperature Flow Cells

Recommended VT air flow rate at 5-15 l/min, and sample flow rate at 0.1-1 ml/sec to provide sufficient heat exchange to maintain desired temperature. Please see page 27 for transfer lines. Fits most Bruker TE<sub>102</sub> and JEOL TE<sub>011</sub> cavities.

Suprasil

Product No.	Sample Volume ( $\mu\text{L}$ )
WG-865-B-Q	85

### Electrolytic Cell

Electrochemistry has been employed in many EPR kinetic studies to generate free radicals. Wilmad-LabGlass offers complete Electrolytic Cell Assemblies with a Suprasil flat cell. Components of an assembly are also available separately as spare parts. Due to the larger gap (0.5 mm) to accommodate the electrode, WG-810-Q is recommended for Bruker ST cavities only. Please contact us for other designs for SHQE and SHQ cavities. Choose WG-810-J-Q for JEOL cavity.

Suprasil

Product No.	Flat Section (A) Width/Length (mm)
WG-810-Q	10.5/60
WG-810-J-Q	10/60

### Accessories

Product No.	Description
18513	Reference Solution-3M KCl saturated with AgCl
18508	Electrode Cleaner, for removing protein coating
18528	Diaphragm Cleaner: Thiol based
18823	Electrode Storage Solution-3M KCl

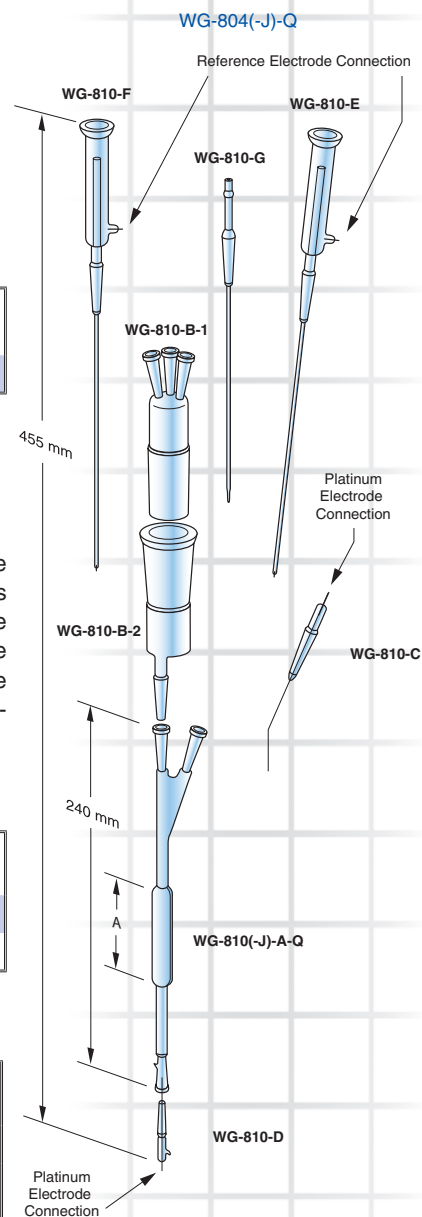
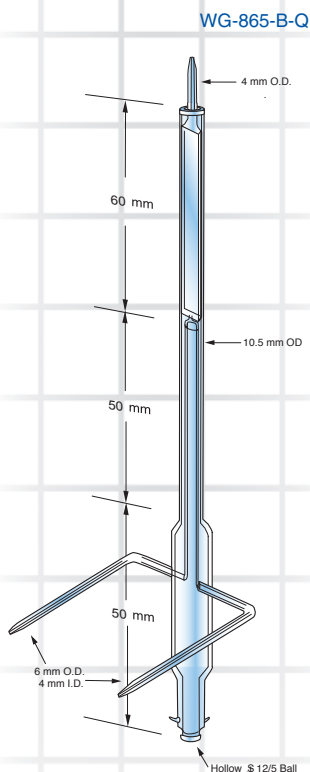

## Parts and Components

Product No.	Description
WG-810-A-Q	Suprasil Flat Section
WG-810-J-A-Q	Suprasil Flat Section for JEOL
WG-810-C	Upper Platinum Electrode, 8"
WG-810-D	Lower Platinum Electrode, 2"
WG-810-E	Short Calomel Electrode, 8-3/4"

Product No.	Description
WG-810-F	Long Calomel Electrode, 13"
WG-810-G	Gas Bubbler
WG-810-B1	Bubbling Chamber Upper Section
WG-810-B2	Bubbling Chamber Lower Section

## Variable Temperature Dewar Inserts and Flasks

WG-821-F(L)-Q  
WG-821-STW-AH(L)-Q

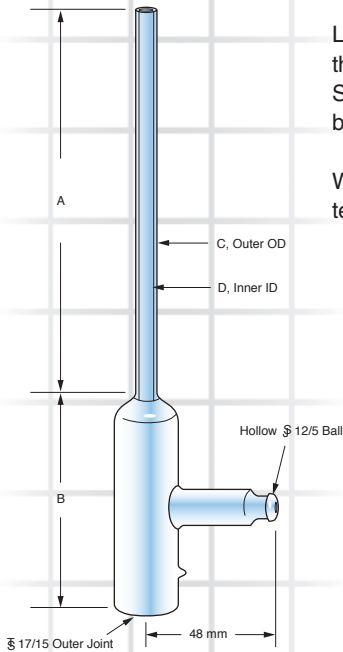

Low temperature EPR brings several benefits to the spectrum, such as an increase in signal levels from samples that have short relaxation time at ambient temperature, enhanced time course resolution for kinetic studies, better SNR due to lower thermal fluctuation. High temperature EPR contributes to certain studies, such as line shape broadening mechanism, phase transition and kinetics.

Wilmad-LabGlass offers a full line of Variable Temperature Dewar Inserts and Flasks from liquid helium temperature to over 1000 K for mainstream EPR VT system.

### Variable Temperature Dewar Insert for Bruker

Bruker style VT Dewar Insert is not silvered, and does not offer dimple to support sample tube. Please check the size of the cavity openings for compatibility. Maximum working temperature is 600 K.

#### Suprasil

Product No.	A (mm)	B (mm)	C (mm)	D (mm)
WG-821-F-Q	147	72	10.5	6
WG-821-STW-AH-Q	147	72	10.0	6.5
WG-821-FL-Q	242	72	10.5	6
WG-821-STW-AHL-Q	175	72	10.0	6.5

### Variable Temperature Dewar Insert for Varian

The lower portion of this Varian style VT Dewar Insert is silvered. Three dimples are provided at reduced section to support sample tubes.

#### Suprasil

Product No.	A (mm)	B (mm)	C (mm)	D (mm)
WG-821-Q	84	63	≤11.4	≥5
WG-822-Q	84	158	≤11.4	≥5

### Variable Temperature Dewar Insert for JEOL

JEOL style VT Dewar Insert differs only slightly from WG-821-F-Q. The side arm ends with a hollow #7 ball for JEOL's original VT systems or hollow 12/5 balls for other VT systems. Maximum working temperature is 600 K.

#### Suprasil

Product No.	Ball Joint
WG-848-Q	Hollow #7
WG-848-A-Q	Hollow 12/5

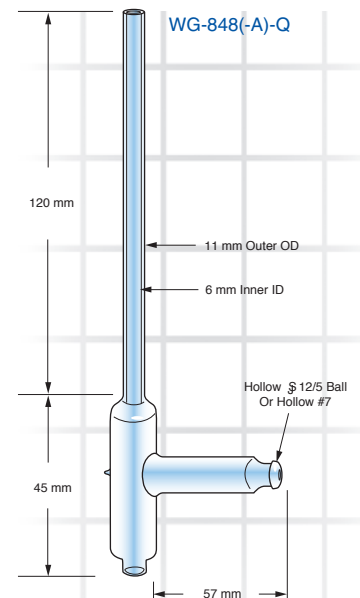
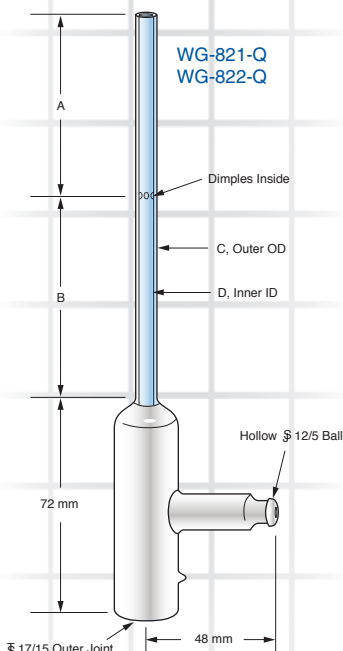

## Universal High Temperature Dewar Insert

Wilmad-LabGlass's WG-821-HT Universal High Temperature Dewar Insert is designed for experiments over 600 K, but is exchangeable to Variable Temperature Dewar Inserts. Choose WG-821-HT-A-Q for Bruker cavities, WG-821-HT-Q for JEOL/Varian cavities.

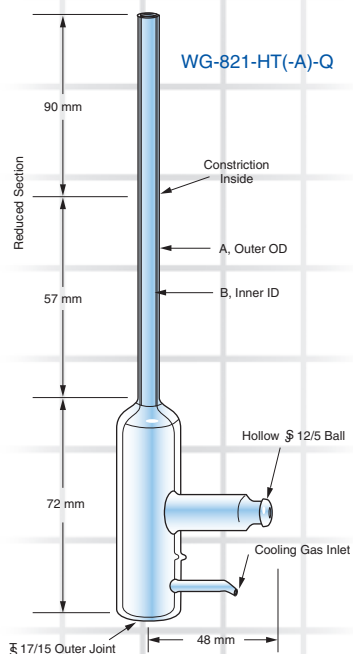

### Suprasil

Product No.	A (mm)	B (mm)
WG-821-HTA-Q	10.5	4.96
WG-821-HT-Q	11	5.44

## High Temperature Dewar Insert for Bruker ER 4131VT

Wilmad-LabGlass offers this High Temperature Dewar for Bruker ER 4114HT-1000 cavity. The three wall finger system made from synthetic quartz yields low thermal expansion coefficient, which results in only a small resonance frequency drift due to wall heating. This Dewar also provides low temperature gradients in the sample region. Use with 750-PQ-7.1 sample tubes (page 4). Maximum working temperature is 1200 K.

### Suprasil

Product No.
DWGSK3352

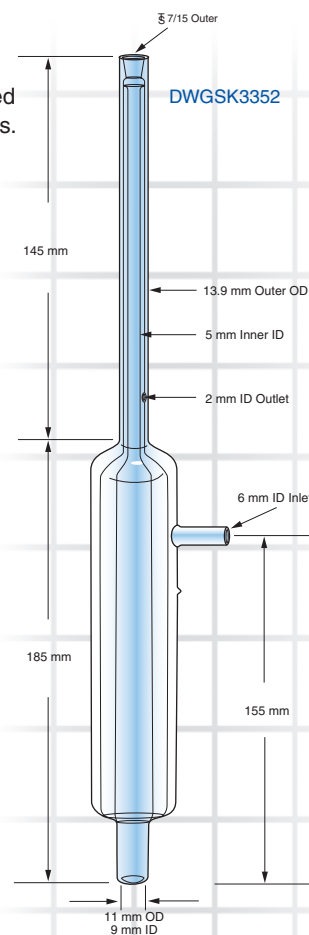

## TM<sub>110</sub> Aqueous Cell Dewar Insert for Bruker

To control your sample temperature in TM flat cells, Wilmad-LaGlass offers WG-821-TMR Dewar Insert for your experiment. The upper section is not vacuum jacketed due to limited space between the large volume aqueous cell and the Bruker TM cavity. The lower portion of the body is silvered to the bottom of the rectangular section.

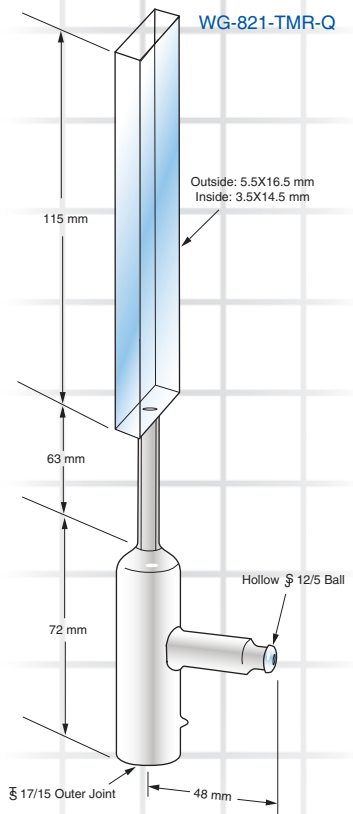

### Suprasil

Product No.
WG-821-TMR-Q

## Room Temperature Simple Dewar Insert

Use these simple dewar inserts to prevent contamination of EPR cavity from sample tube breakage, or for balancing the loads in dual cavity resonator.

### For Bruker Cavity

### Suprasil

Product No.	A (mm)	B (mm)	C (mm)	D (mm)
WG-824-F-Q	200	-	6	10.5
WG-826-F-Q	180	60	6	10.5

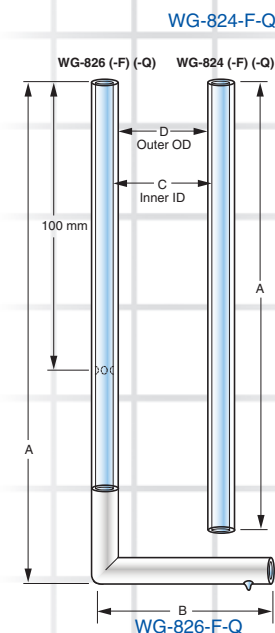

For JEOL and Varian Cavity

Suprasil

Product No.	A (mm)	B (mm)	C (mm)	D (mm)
WG-824-Q	200	-	5	11
WG-826-Q	180	60	5	11

### Cold Finger Liquid Nitrogen Dewar Flask

These Dewar Flasks provide a convenient alternative to VT systems for studies at 77 K, and are silvered around the reservoir. 50 mL flasks last 15 minutes, 150 mL 30 minutes, after a filling. The offset versions (WG-819 and WG-853) are designed for cavities that have limited space between the reservoir and the drive shaft for iris.

#### 50 mL Dewar Flask for Bruker

Suprasil

Product No.	Style	A (mm)	B (mm)	C (mm)	D (mm)	E (mm)
WG-816-B-Q	Symmetric	5.4	10	22	86	162
WG-816-D-Q	Symmetric	4.5	8	22	86	162
WG-819-B-Q	Offset	5.4	10	22	105	178

#### 50 mL Dewar Flask for Others

Suprasil

Product No.	Style	A (mm)	B (mm)	C (mm)	D (mm)	E (mm)
WG-816-Q	Symmetric	4.9	11.4	22	86	162
WG-819-Q	Offset	4.9	11.4	22	105	178

#### 150 mL Dewar Flask for Bruker

Suprasil

Product No.	Style	A (mm)	B (mm)	C (mm)
WG-850-B-Q	Symmetric	6.09	10	37
WG-853-B-Q	Offset	6.09	10	37

#### 150 mL Dewar Flask for Others

Suprasil

Product No.	Style	A (mm)	B (mm)	C (mm)
WG-850-Q	Symmetric	6.09	11.4	37
WG-853-Q	Offset	6.09	11.4	37

WG-816-B-Q  
WG-816-D-Q  
WG-819-B-Q

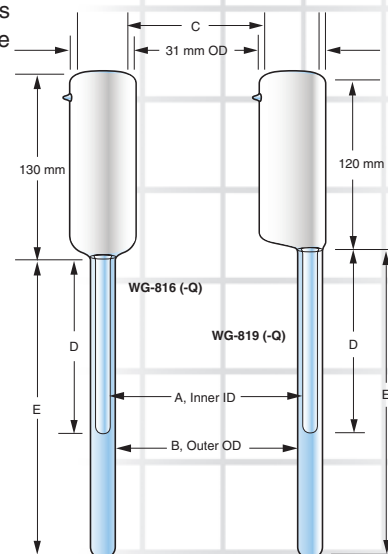

WG-850(-B)-Q  
WG-853(-B)-Q

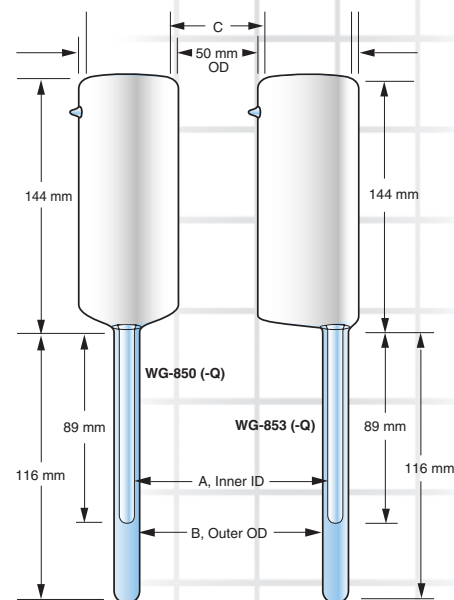

**Note 1:** To minimize bubbling, please keep the inner wall clean. It also helps to precool the dewar flask with liquid nitrogen and fill in sample directly without using a sample tube.

## Dewar Insert for Loop-gap Cavity

WG-895 Dewar Insert is made of high quality quartz and designed to allow insertion of the loop-gap resonator inside the Dewar Insert. The lower portion is silvered for enhanced thermal stability.

CFQ

Product No.
WG-895

## Transfer Lines

The cold gas transfer line is another essential part for VT system. Wilmad-LabGlass manufactures various transfer lines for mainstream VT setup. All are made of high quality quartz and fully silvered to minimize heat loss and any mechanical stress due to quartz's low thermal expansion rate. Please contact us for customized requirements.

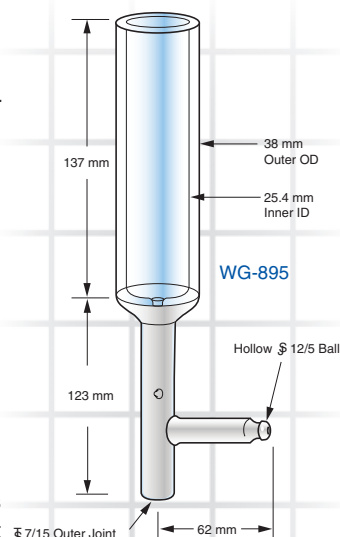

## Simple Transfer Line

90° angle

CFQ

Product No.	A (mm)
WG-840	308
WG-840-L	346
WG-840-XL	416

180° angle

CFQ

Product No.
WG-843-B

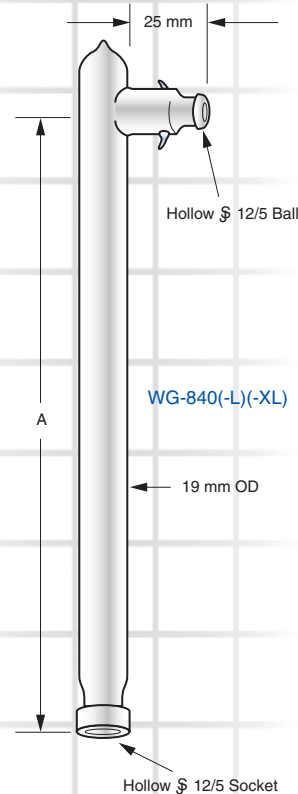

## Immersion Transfer Line

Wilma-LabGlass's Immersion Transfer Line incorporates a Kovar flange that fits stainless steel heat exchanger. Kovar has the same thermal expansion as the stainless steel, which makes this transfer line ideal for any VT system with open liquid nitrogen reservoir.

CFQ

Product No.
WG-760

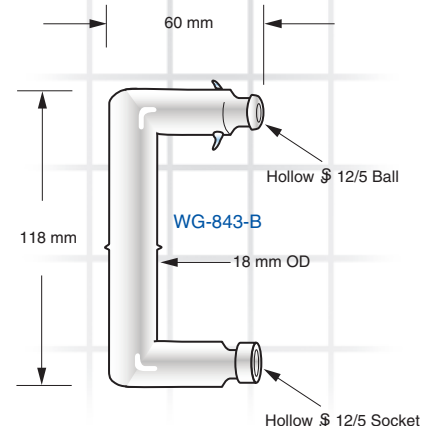
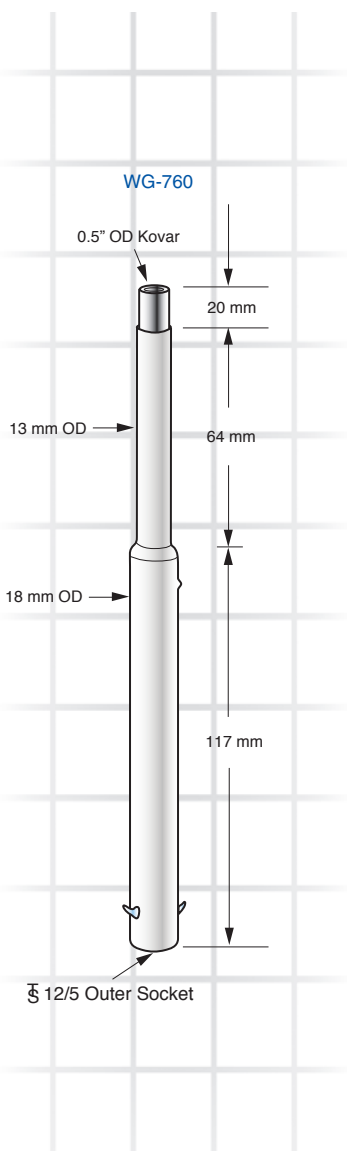

# Transfer Line with Heater Inlet

## Bruker Style

These transfer lines are designed for Bruker ER4121 VT systems. The longer (WG-842-MX and WG-842-ML) versions are recommended for Bruker ER 4121 VT system in an EPR console with magnet >18 cm diameter.

### CFQ

Product No.	A (mm)	B (mm)	C (mm)
WG-842	425	75	75
WG-842-MX	725	75	98
WG-842-ML	725	75	110
WG-842-MRL	768	118	110

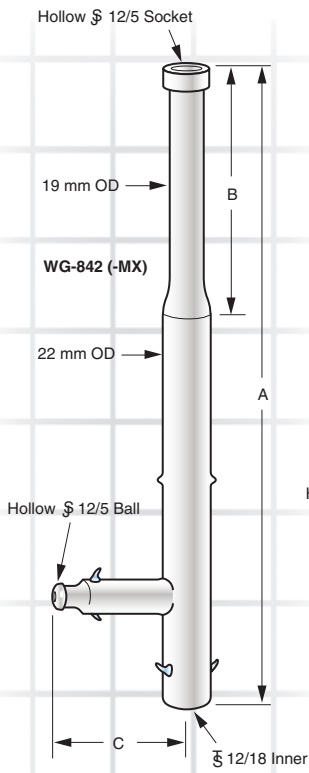

WG-842(-MX)(-ML)

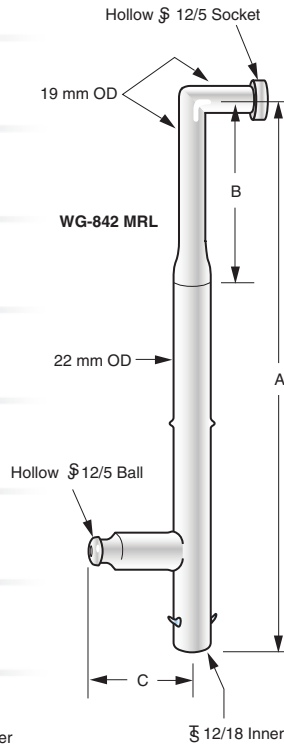

WG-842-MRL

## Other Styles for Customized VT Systems

These transfer lines will add flexibility to any customized VT system. WG-836-A and WG-837-A have a standard glass taper seal at the bottom for better insulation.

### Straight

#### CFQ

Product No.	Bottom Joint	A (mm)
WG-836	none	299
WG-837	none	406
WG-836-A	1/2 19/38	387
WG-837-A	1/2 19/38	447

### 90° angle

#### CFQ

Product No.	Bottom Joint	A (mm)
WG-836-B	none	328
WG-837-B	none	436

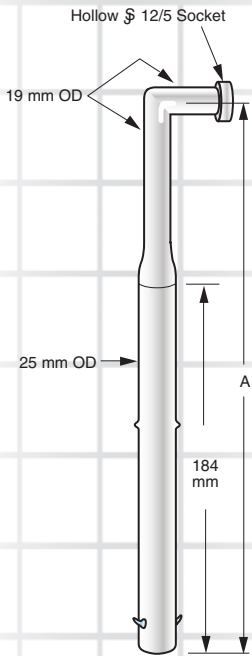

WG-836-B  
WG-837-B

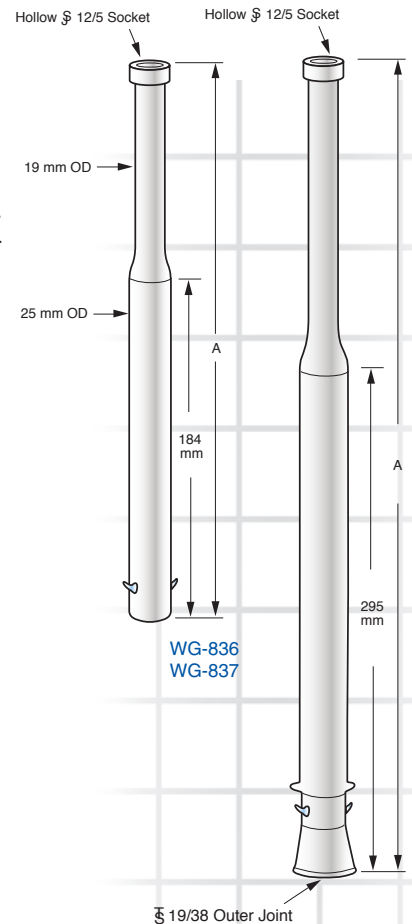

WG-836  
WG-837

WG-836-A  
WG-837-A

**Note 1:** Wilmad-LabGlass also manufactures various heaters and sensors with quartz protection cover. Please contact our engineers to discuss VT solutions for your EPR console.



## PRODUCT INDEX BY BRUKER'S PART NUMBER

Bruker/Wilma-LabGlass Part Number	Page	Bruker/Wilma-LabGlass Part Number	Page
ER 160FC-B-Q/WG-853-B-Q .....	25	ER 178MCVT/WG-865-B-Q .....	22
ER 160FC-Q/WG-812-Q .....	19	ER 221CT-Q/Q-1.91M-4.60M .....	CALL
ER 160FC-S-Q/WG-812-S-Q .....	19	ER 221ET/Q-5.5M-6.3M-0-200M .....	CALL
ER 160FC-S-Q-ESCAN/WG-812-S-Q-SP .....	CALL	ER 221LT/705-PQ-7.1 .....	CALL
ER 161FCTM-Q/WG-813-Q .....	20	ER 221NT/710-SQ-250M .....	2
ER 161FCTM-S-Q/WG-813-S-Q .....	20	ER 221PT/714-PQ-8 .....	2
ER 162TC-Q/WG-806-A-Q .....	21	ER 221PTL/715-PQ-250M .....	2
ER 162TCTM-Q/WG-806-B-Q .....	21	ER 221PTLS/735-PQ-250M .....	3
ER 163MC-Q/WG-804-Q .....	22	ER 221PTS/734-PQ-8 .....	3
ER 164EC/WG-810-Q .....	22	ER 221QT/704-PQ .....	2
ER 165FCVT-Q/WG-808-Q .....	21	ER 221QT1/Q-.8X1.0 .....	3
ER 165FCVT-S-Q/WG-808-S-Q .....	21	ER 221ST/707-SQ-250M .....	2
ER 166FCTMVT-Q/WG-813-TMS-Q .....	21	ER 221WT/713-5PQ-200M .....	2
ER 166FCTMVT-S-Q/WG-813-TMS-S-Q .....	21	ER 221WTS/733-3PQ-7 .....	3
ER 167FD-Q/WG-816-B-Q .....	25	ER 222HTT/750-PQ-7.1 .....	4
ER 167LD-Q/WG-850-B-Q .....	25	ER 4121VT-1005/WG-842-MX .....	27
ER 167OD-Q/WG-819-B-Q .....	25		
ER 167SD-Q/WG-816-D-Q .....	25		
ER 168DIL-Q/WG-821-FL-Q .....	23		
ER 168DI-Q/WG-821-F-Q .....	23		
ER 168LG/WG-895 .....	26		
ER 169DB-Q/WG-824-F-Q .....	24		
ER 169DIS-Q/WG-821-STW-AH-Q .....	23		
ER 169DIT-Q/WG-816-D-Q .....	25		
ER 170DIM-Q/WG-821-TMR-Q .....	24		
ER 172AC-Q/WG-821-HTA-Q .....	24		
ER 172DIH-P/DWGSK3352 .....	24		
ER 173VTB/WG-843-B .....	26		
ER 173VTT-1/WG-842 .....	27		
ER 173VTT-10/WG-842-MX .....	27		
ER 173VTT-10R/WG-842-MRL .....	27		

# Wilmad-LabGlass is Your Complete One-Stop Laboratory Glassware Resource

Call 800.220.5171, 856.691.3200, or visit [www.wilmad-labglass.com](http://www.wilmad-labglass.com) to request your free copy of our latest catalogs

## *Nuclear Magnetic Resonance Consumables Catalog*

Our 60 years of experience places Wilmad-LabGlass in an ideal position to offer high quality consumables for NMR spectroscopy. Our NMR consumables catalog contains an extensive collection of 100 MHz to 1000 Mhz regular glass tubing, ultra vacuum to 300 psi pressure gas-tight products, small volume consumables with as little as 18  $\mu$ L capacity, susceptibility matched tubes, washers, dewar flasks, spinners, solid state consumables and various accessories.



## *Precision Engineered (Precision Bore) Glass*

Wilmad-LabGlass offers 60 years of precision bore glassware manufacturing experience. Our engineers can configure a glass or quartz product to your specification within 10  $\mu$ m tolerance. We have served various industries which include but are not limited to automotive, medical imaging, pharmaceutical R&D, basic research, environmental protection, QC/QA, aerospace (both civilian and military), high power laser window and magnetic flowmeter. To request a quote, visit our website at [www.Wilmad-LabGlass.com/request/index.jsp](http://www.Wilmad-LabGlass.com/request/index.jsp) and complete the form with your specifications.



## *Laboratory Glassware and Equipment Catalog*

Wilmad-LabGlass has been a leader in the manufacture of full line laboratory glassware that ranges from measuring cylinders, beakers, custom labware to distillation apparatus and pilot plant reactors. Our strategic partnerships with many top notch manufacturers enable us to provide one of the most complete product lines in the industry.

**The market of quartz is volatile. Prices shown in this catalog are based on raw material cost in April 2011, and subject to change without notice. Please visit our website for the most up to date offerings and features!**



To check the current discount rate for your institute or corporation, please contact customer service at [cs@wilmad-labglass.com](mailto:cs@wilmad-labglass.com) or call 800-220-5171 or 856-691-3200

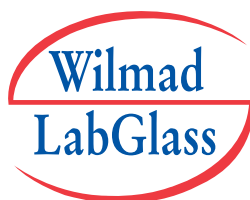

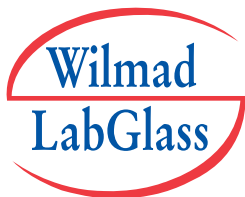

*an SP Industries Company*

*Committed to Product Excellence and Continuous Support*

SP Service

VirTis

Hull

Wilma-LabGlass

Genevac

FTS

Hotpack

**SP Industries Corporate Headquarters:**

935 Mearns Road Warminster, PA 18974 USA Tel: 800.523.2327 215.672.7800 Fax: 215.672.7807 [www.SPindustries.com](http://www.SPindustries.com)