



Scroll Compressor

Service and Maintenance Manual

CONTENTS

MAINTENANCE SCHEDULE	3
INTAKE AIR FILTER REPLACEMENT	4
COOLING FIN CLEANING	7
BLOWER FAN CLEANING	10
FAN DUCT CLEANING	12
REGREASE BEARINGS	13
TIP SEAL SET REPLACEMENT	22
PARTS LIST	34

MAINTENANCE SCHEDULE

Item	Action needed	Page	Operating Hours					Remarks
			500	2,500	5,000	10,000	15,000	
Intake air filter	Replace	4	●	▲	(Every 2,500 hours or less)		Part #91348550	
Cooling fins	Clean	7		●	(Every 2,500 hours or less)			
Blower fan	Clean	10			●	●	●	
Fan duct	Clean	12			●	●	●	
Bearings	Regrease	13	(Every 5,000 hours for high pressure model)			●		Service Center Only
Tip Seal set	Replace	22	(Every 5,000 hours for high pressure model)			▲		

● : Inspect

▲ : Replace

NOTES:

1. Inspect and perform maintenance periodically according to maintenance schedule.
2. The maintenance schedule relates to the normal operating conditions. If the circumstances and load condition are adverse, shorten the cycle time and do maintenance accordingly.
3. *The tension of the V-belt should be adjusted during the initial stage and inspected every 2,500 hours afterwards. Proper belt tension for 3 HP unit is 7 lbs./0.16" deflection; for 5 HP units, 7 lbs./0.19" deflection.
4. Air end life is as below.
Regular pressure model: 20,000 hours, High pressure model: 15,000 hours

INTAKE AIR FILTER REPLACEMENT

every 2,500 HOURS – MAINTENANCE

1. Remove the Filter Cover.



2. Change the Filter Element (part number 91348550)



CAUTION

Do not attempt to clean the filter element. This filter requires replacement and is to be replaced when contaminated.

3. Reassemble the Filter Cover.



COOLING FIN CLEANING

every 2500 HOURS - MAINTENANCE

1. Remove the FS (Fixed Scroll) cover.

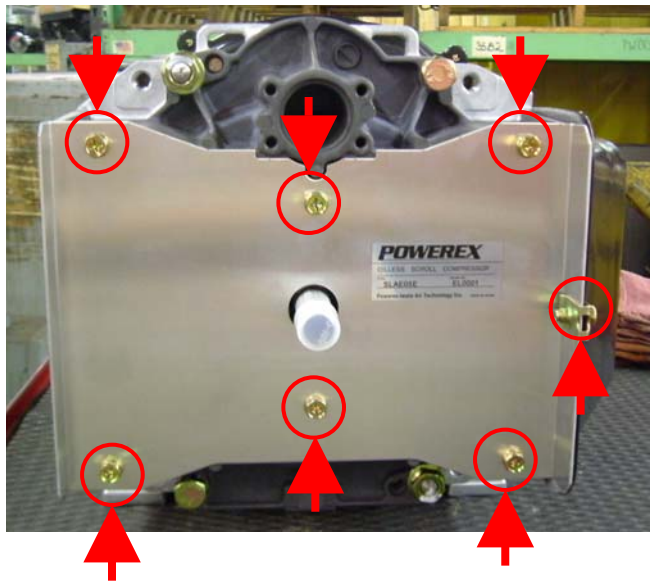

Remove these seven bolts.

2. Clean FS fins with a blow gun.



3. Reassemble the FS cover.

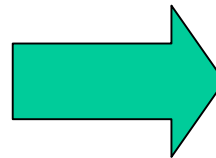

BLOWER FAN CLEANING

every 5,000 HOURS – MAINTENANCE

1. Remove five screws and take the Fan Cover off.

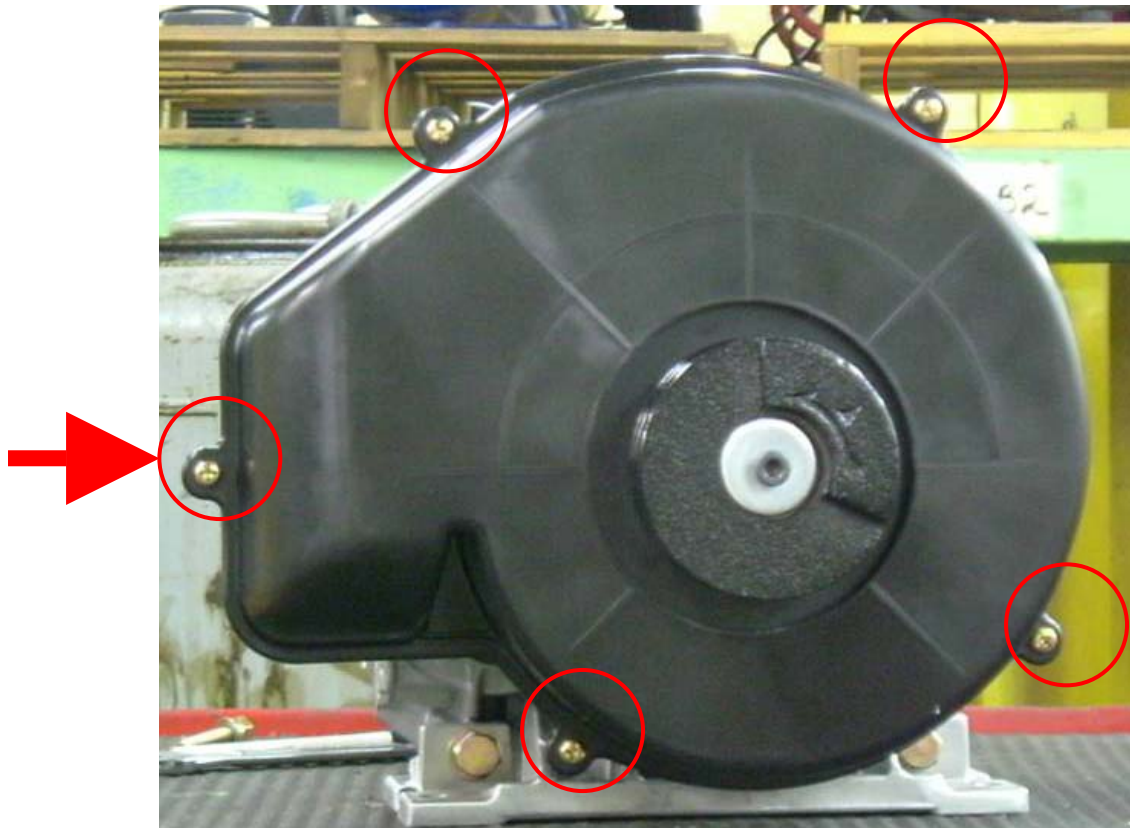

2. Blow off dirt and dust



FAN DUCT CLEANING

5,000 HOURS MAINTENANCE

Wipe out dirt and dust



REGREASE BEARINGS

every 5,000 HOURS – MAINTENANCE (High pressure model)

10,000 HOURS – MAINTENANCE (Regular pressure model)

WARNING

Per OSHA regulations, ALL power must be locked out before performing any maintenance.

CAUTION

This service should be performed by an authorized Powerex Service Center to avoid failure.

1. OS BEARING
 - i. Remove the Plastic Dust Cap.

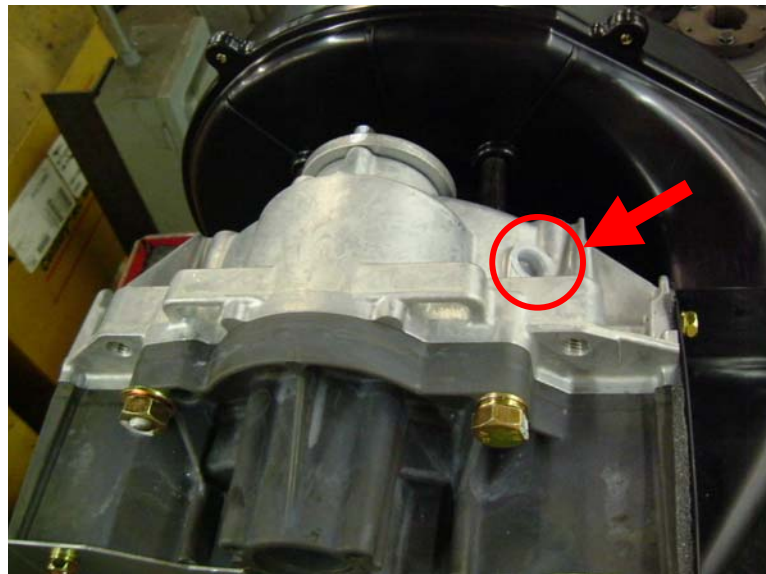

- ii. Rotate the Compressor Pulley until the grease fitting is visible through the dust cap hole.

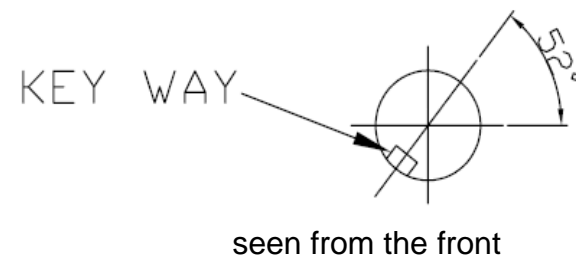

iii. Prepare a grease gun.

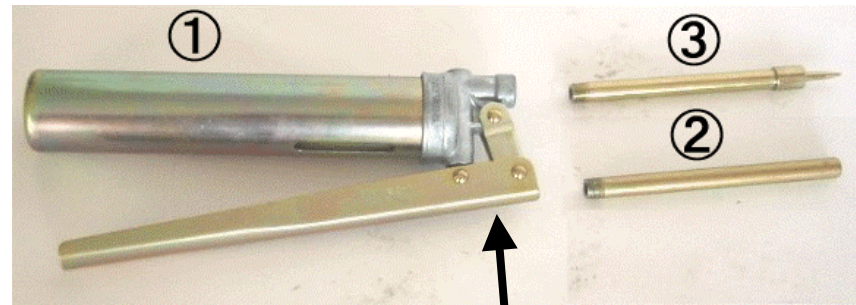
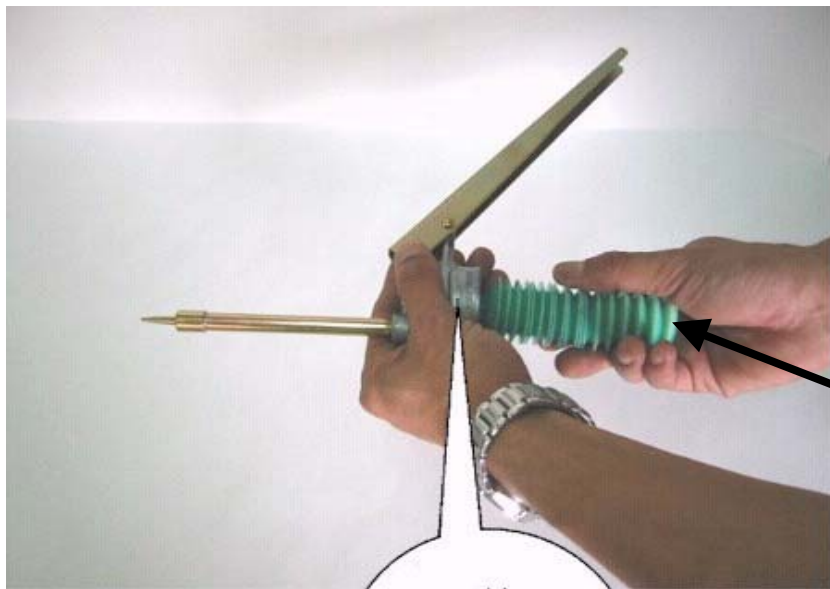

Grease Gun

Cartridge Grease

CAUTION

Use only Powerex genuine grease. Pump grease gun before using feeding (this eliminates air from the grease passage of the extension adaptor).

Part Number: IP616200AJ (complete kit), IP600000AV (grease tube)

- iv. Use a grease gun extension adaptor to enlarge the grease fitting and supply the power volume of grease as indicated below table.

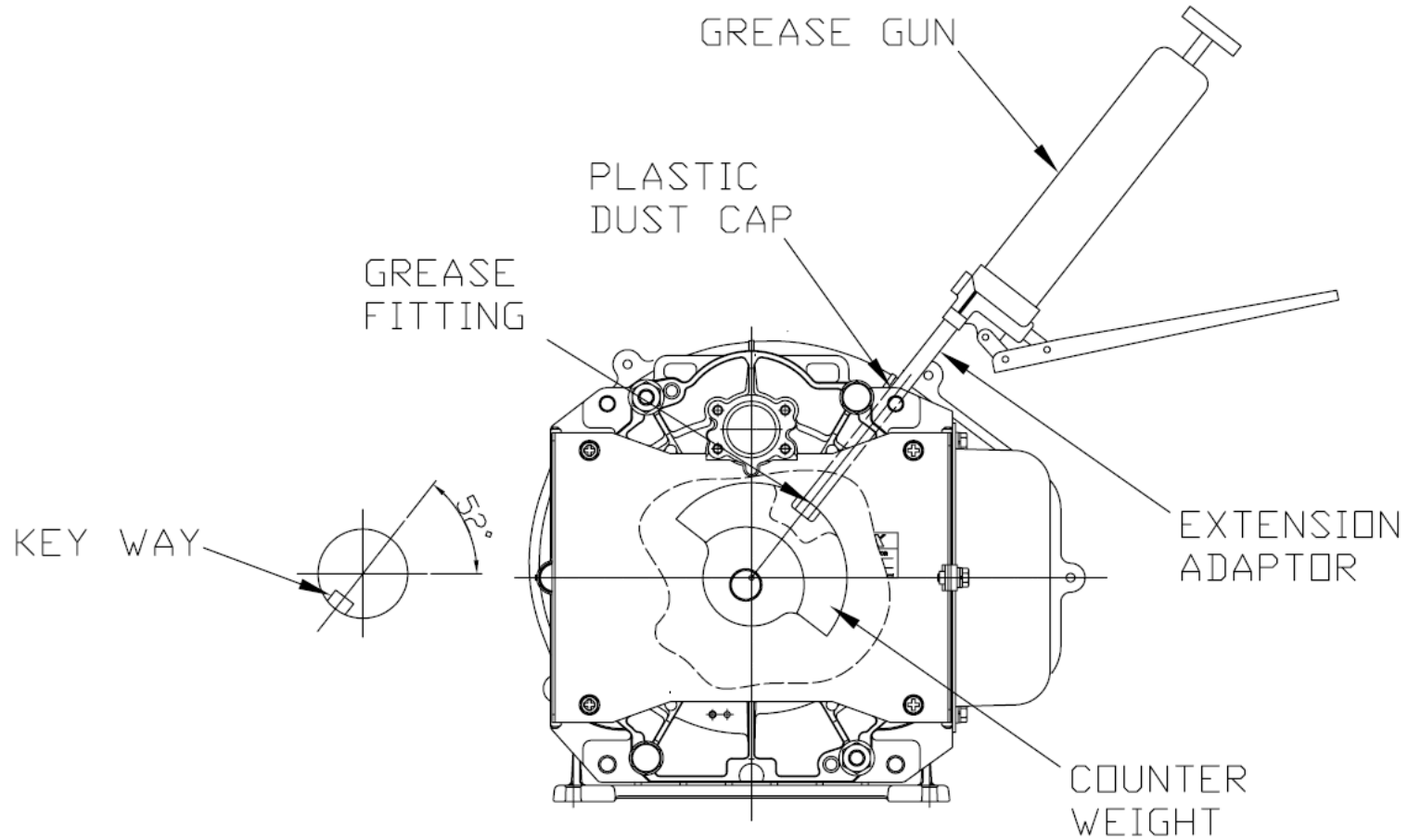

Grease delivery (OS Bearing)

SLAE03E		SLAE05E		SLAE05EHP	
1st time	2nd time	1st time	2nd time	1st time	2nd time
5 times	4 times	7 times	6 times	7 times	6 times

Note: Each pump of the grease gun equals 0.65 g of grease.

- v. Put the removed Plastic Dust Cap back.

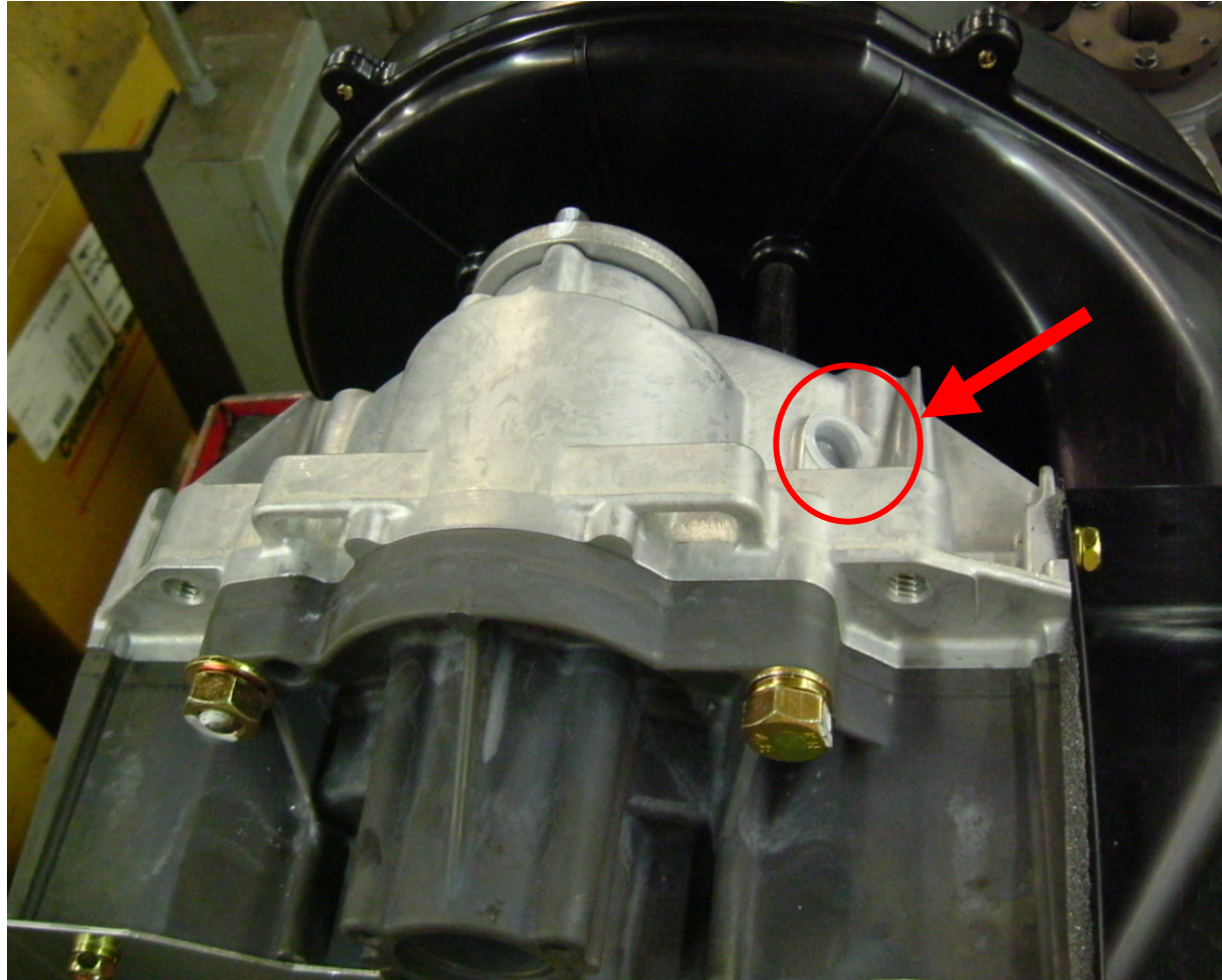

2. PIN CRANK BEARINGS

- i. Remove the Fan Duct (2)

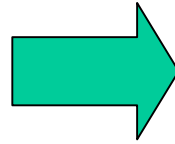
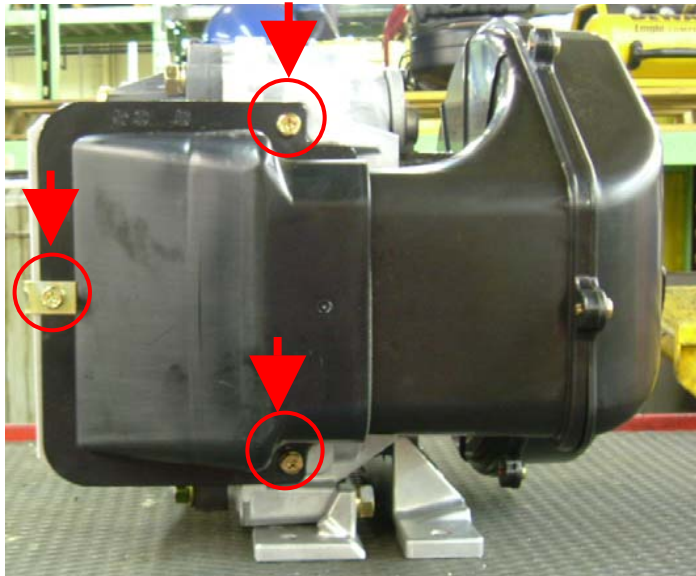

Remove these three bolts.

ii. Remove FS (Fixed Scroll) Set

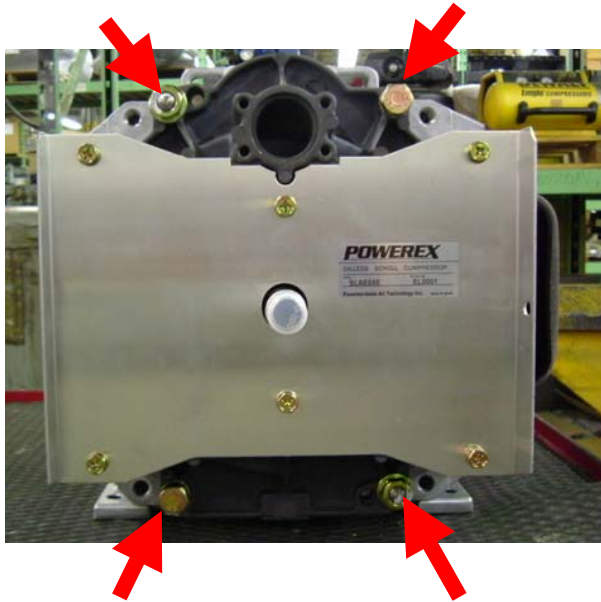
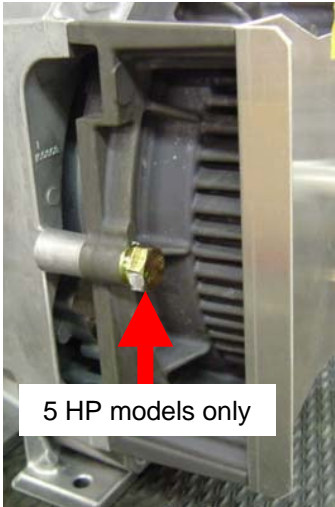

Remove bolts and nuts and remove the FS

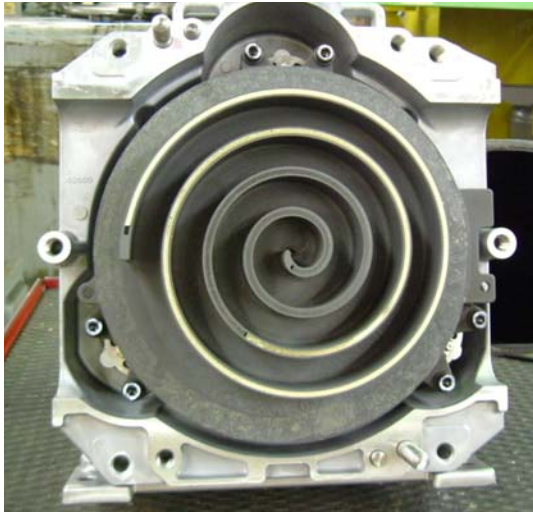
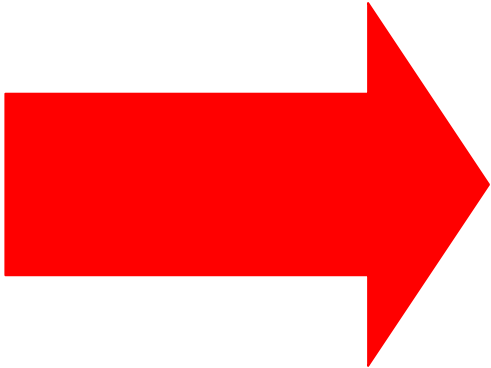

- iii. Use a grease gun to enlarge the grease fitting and supply the power volume of grease as indicated below table. Grease all three pin crank bearings from the grease fittings.

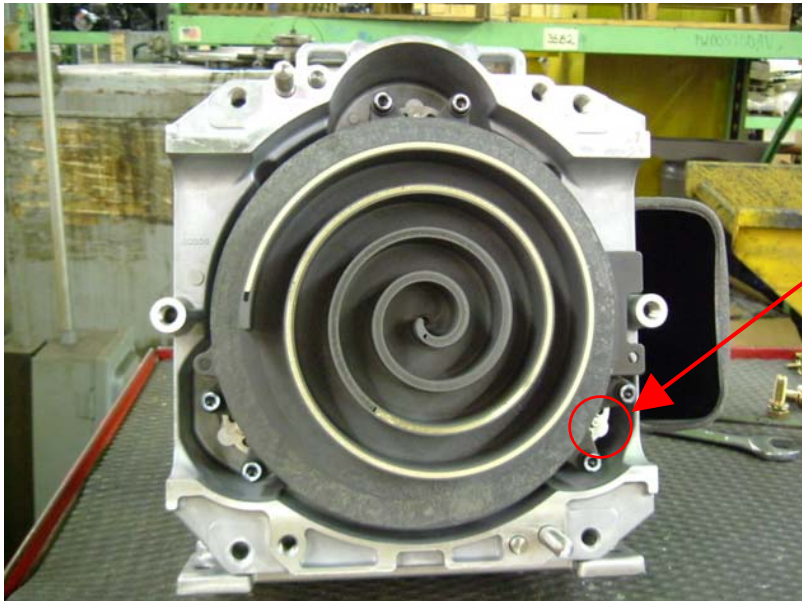

Grease fitting

Grease delivery (Pin crank bearings)

SLAE03E		SLAE05E		SLAE05EHP	
1st time	2nd time	1st time	2nd time	1st time	2nd time
4 times	4 times	5 times	5 times	7 times	7 times

Notes: Each pump of the grease gun equals 0.65 g of grease.

CAUTION

Use only Powerex genuine grease. Pump grease gun before using feeding (this eliminates air from the grease passage of the extension adaptor).

Part Number: IP616200AJ (complete kit), IP600000AV (grease tube)

- iv. Replace the FS set and fan duct (2). Tighten bolts and nuts temporarily and confirm if crankshaft rotates smoothly by hand and tighten them firmly. Tightening torques are as below.

Tightening torque

SLAE03E		SLAE05E / SLAE05EHP	
First	Second	First	Second
17 in-lb	175 in-lb	17 in-lb	265 in-lb

NOTE: Assemble so that dust seal and tip seal will not drop between Orbit (OS) scroll and FS scroll set.

TIP SEAL SET REPLACEMENT

every 5,000 HOURS – MAINTENANCE (High pressure model)

10,000 HOURS – MAINTENANCE (Regular pressure model)

WARNING

Per OSHA regulations, ALL power must be locked out before performing any maintenance.

CAUTION

This service should be performed by an authorized Powerex Service Center to avoid failure.

1. CONFIRMATION OF THE PARTS

- i. Confirm if the Tip Seal you purchased is correct for the air end you are replacing (see below parts listing).

Tip Seal Set

SLAE03E	SLAE05E	SLAE05EHP
92834090	92832070	92832080

ii. Confirm if the parts are correctly included.

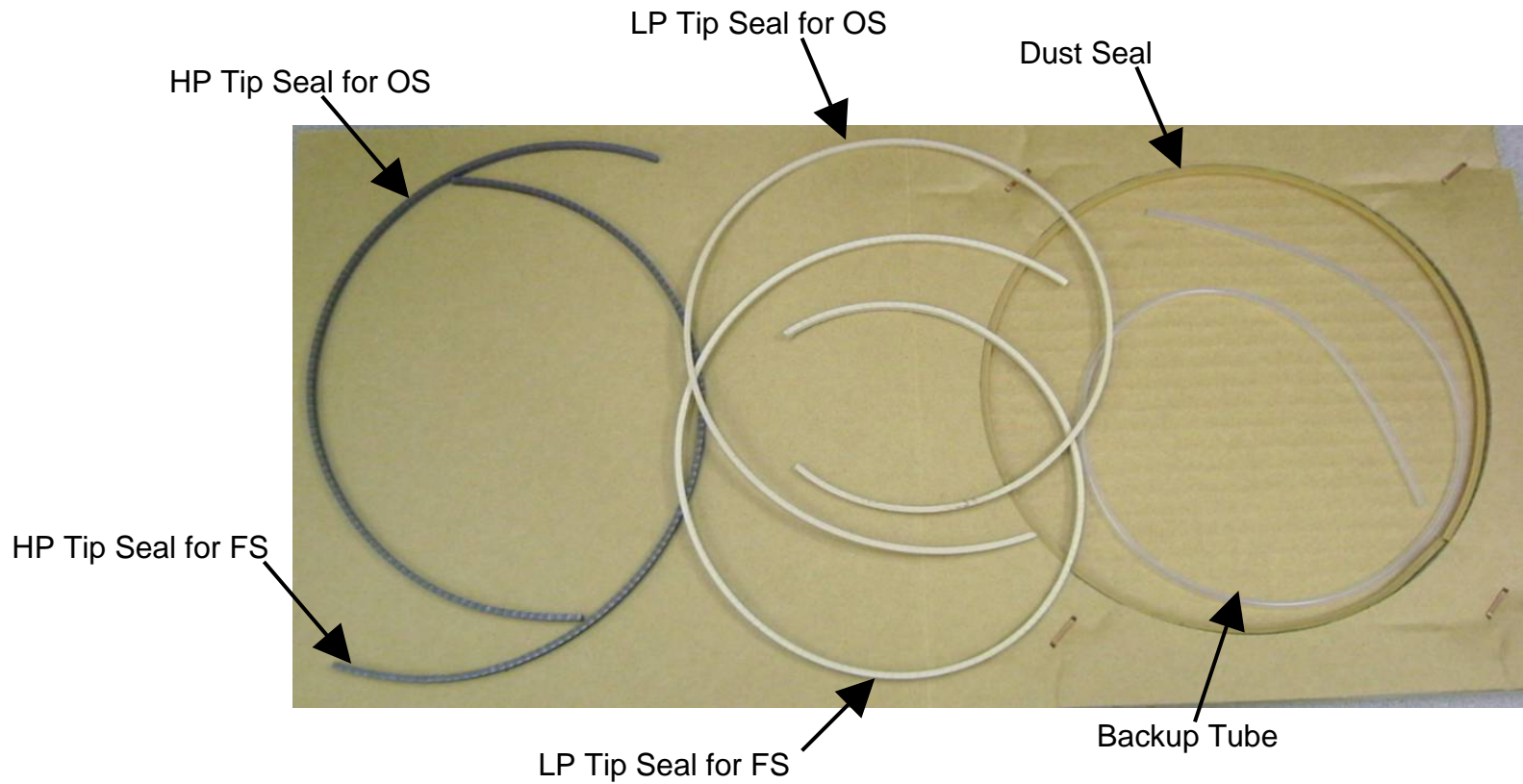

HP = High Pressure LP = Low Pressure
FS = Fixed Scroll OS = Orbital Scroll

2. REPLACEMENT

- i. Remove the fan duct (2)

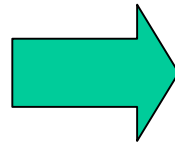
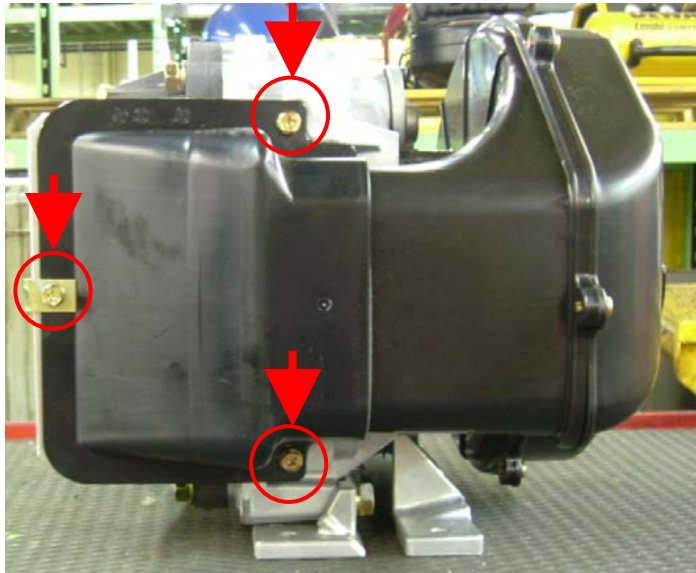

Remove these bolts.

ii. Remove FS (Fixed Scroll) Set

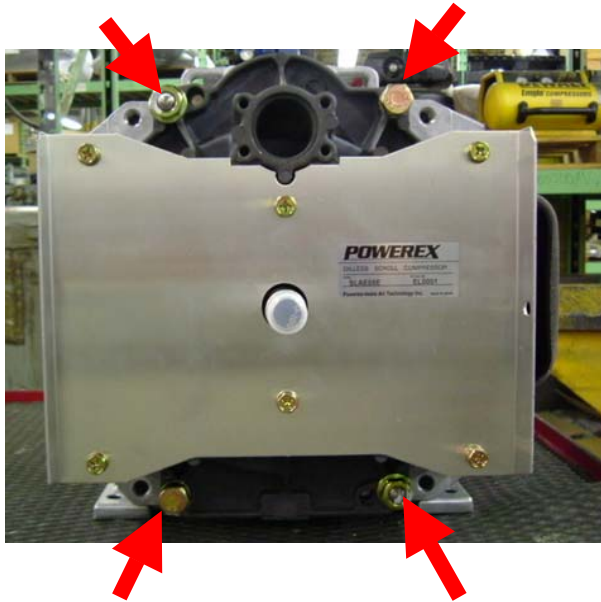
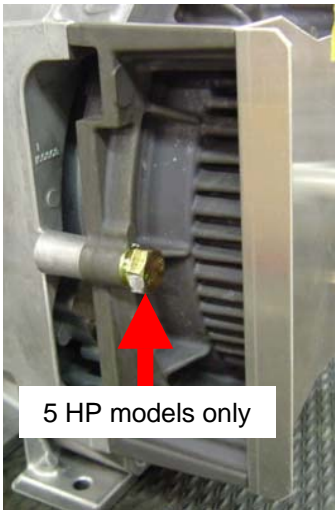

Remove bolts and nuts and remove the FS

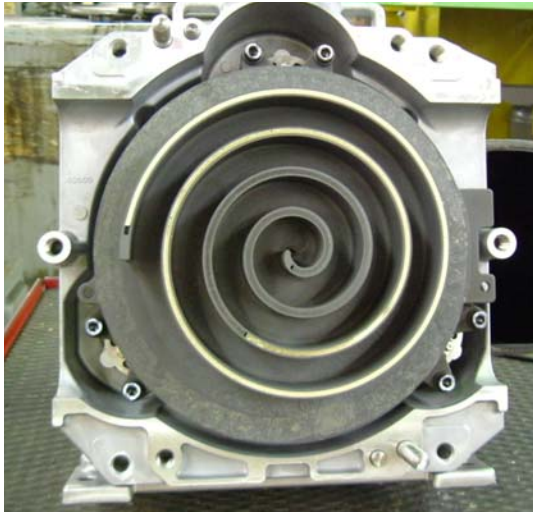
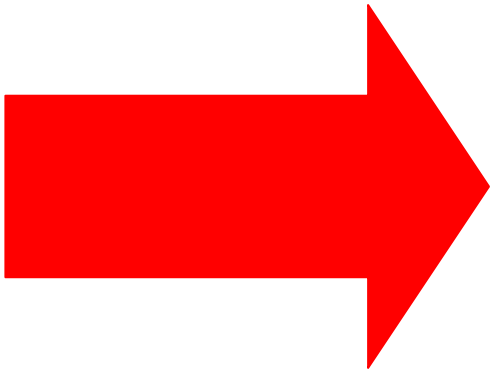

- iii. Remove the LP and HP Tip Seals, the Dust Seal and the Backup Tube from FS (Fixed Scroll) and OS (Orbital Scroll) sets. Using the tip of a ball-point pen at the start will make it much easier.



LP Tip Seal

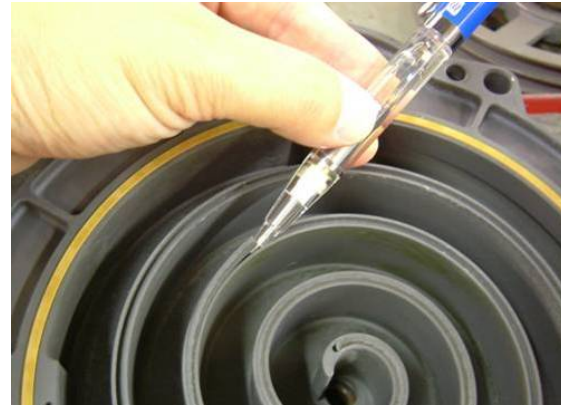

HP Tip Seal

※ You have to remove LP Tip Seal first



Dust Seal



Backup Tube

※ Backup Tube is under the Dust Seal.

iv. Remove dust from both OS and FS plates with clean cloth or air.

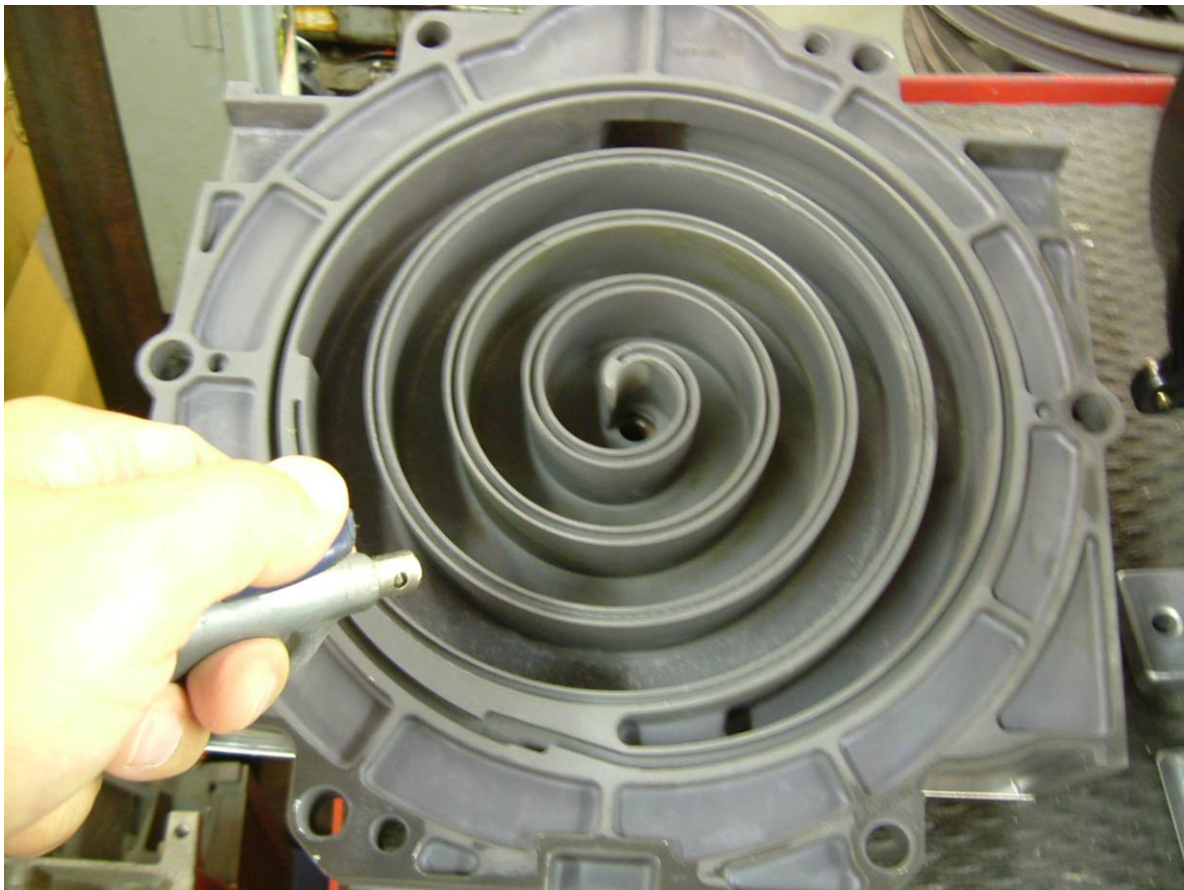

- v. Insert new HP Tip Seal from the center section of OS set so that there will be no clearance at the start section.

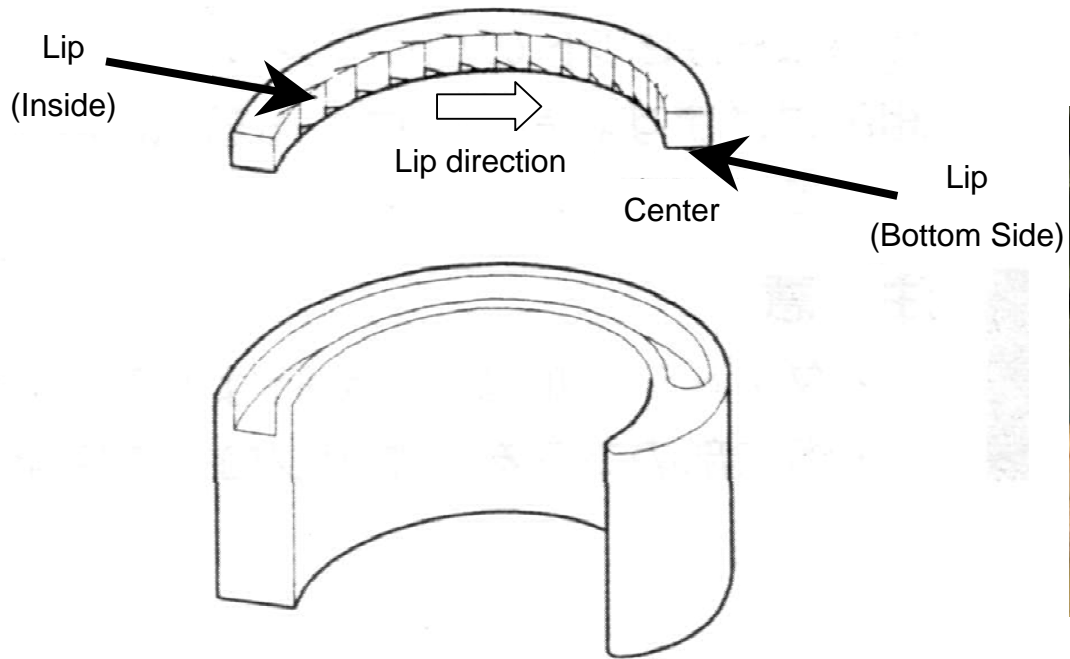

CAUTION

Tip Seals for OS and FS have opposing seal cut angles. Insert Tip Seal so that the lip seal on the bottom of seal groove and inner side of scroll spiral and the direction of lip faces the center of scroll spiral. This is to be done both OS and FS sets, otherwise, air end cannot make enough air.

- vi. Insert so that new LP Tip Seal will contact closely with HP Tip Seal inside scroll groove.

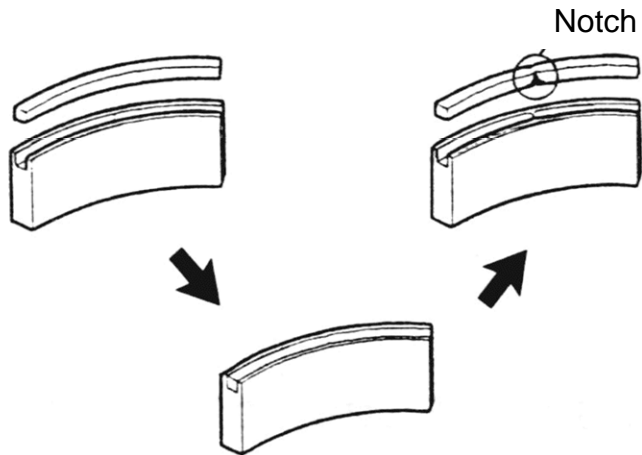

CAUTION
Insert approximately half of the LP Tip Seal and remove the Tip Seal to confirm that a notch in the Tip Seal has been achieved. This will prevent movement during running. Before reinserting, remove dust around the notch.

vii. Insert LP Tip Seal all the way and cut excessive material.

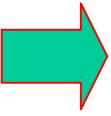
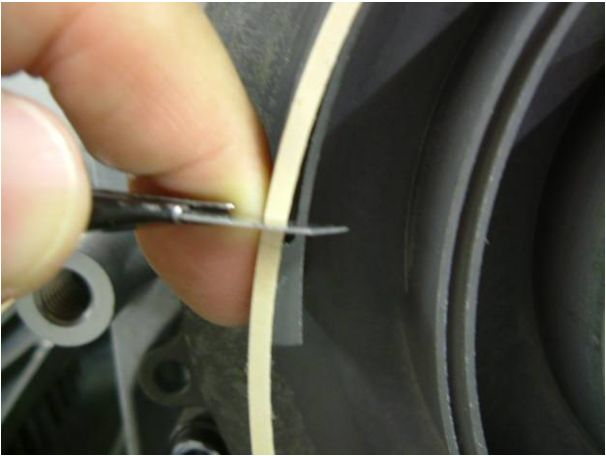

viii. Repeat the same procedure for FS Tip Seal set.



ix. Insert new Backup Tube in the FS, then insert new Dust Seal on the Backup Tube.

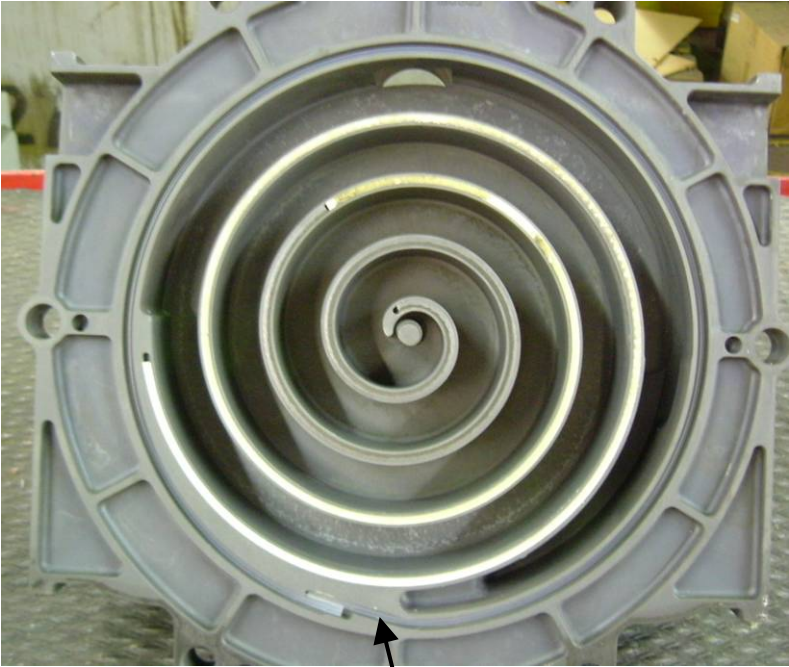

Backup Tube

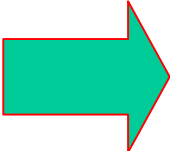

Dust Seal

- x. After replacing Tip Seal Set, reassemble the FS set and fan duct (2) to the air end. Tighten bolts and nuts temporarily and confirm if crankshaft rotates smoothly by hand and tighten them firmly. Tightening torques are as below.

Tightening torque

SLAE03E		SLAE05E / SLAE05EHP	
First	Second	First	Second
17 in-ib	175 in-lb	17 in-ib	265 in-lb

NOTE: Assemble so that dust seal and tip seal will not drop between Orbit (OS) scroll and FS scroll set.

PARTS LIST

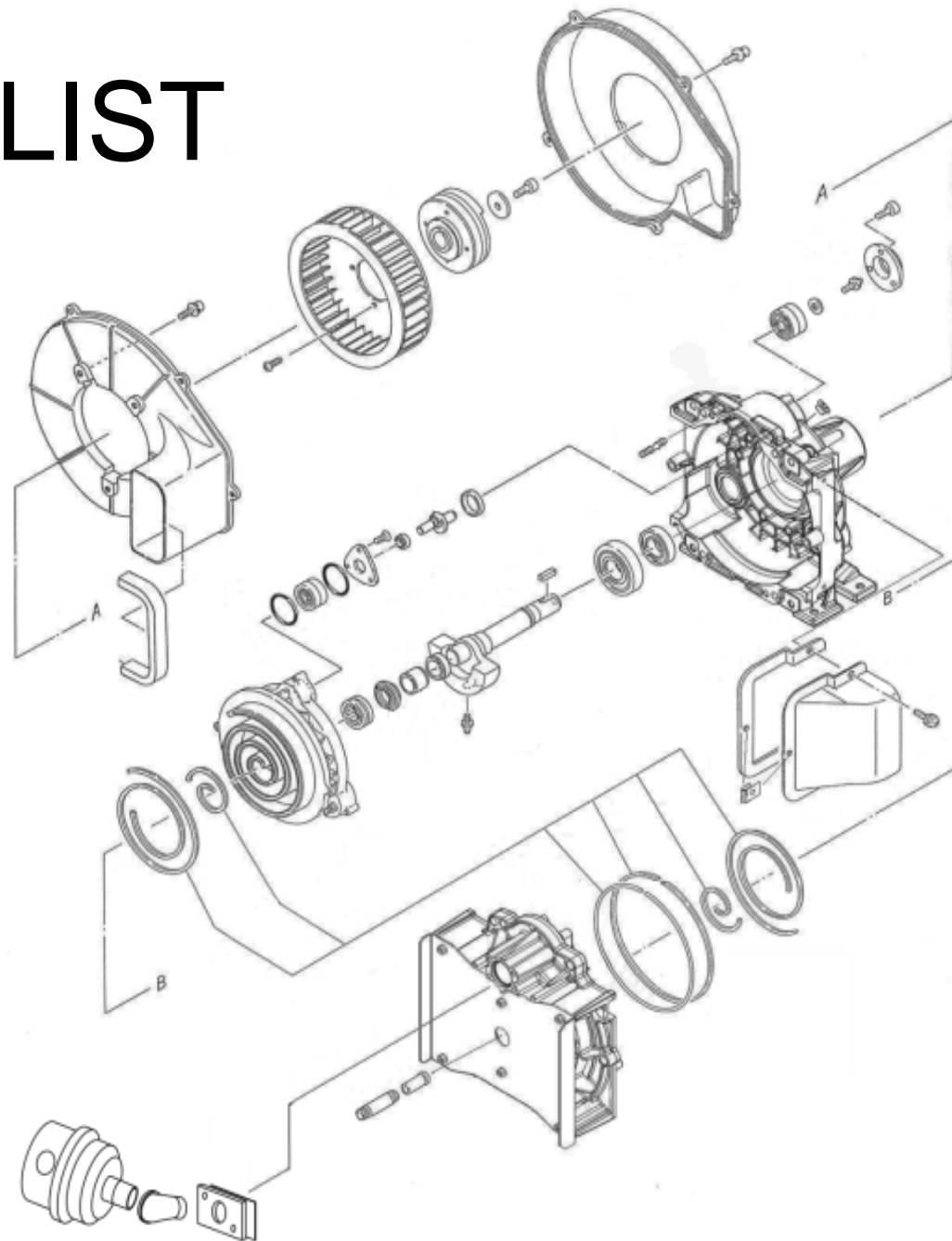

Description	Parts number for models			Quantity
	SLAE03E	SLAE05E	SLAE05EHP	
Air end pulley	92843051	92549110	92549110	1
Key	IP600600AV	IP600600AV	IP600600AV	1
Centrifugal fan	IP601300AV	IP601300AV	IP601300AV	1
Fan Duct (1)	IP601400AV	IP601400AV	IP601400AV	1
Fan Duct (2)	IP601500AV	92519042	92519042	1
Fan Cover	IP601700AV	IP601700AV	IP601700AV	1
Fan Duct Gasket (1)	IP601800AV	IP601800AV	IP601800AV	1
Heat Insulation Pipe	IP602000AV	IP602000AV	IP602000AV	1
Fan Duct Gasket (2)	IP602400AV	IP602400AV	IP602400AV	1
Long Nipple	96647011	96647011	96647011	1
Dust Cap	IP603500AV	IP603500AV	IP603500AV	1
Tip Seal Set	92834090	92832070	92832080	1
Filter Assembly	ST073922AV	ST073922AV	ST073922AV	1
Filter Element	91348550	91348550	91348550	1
Street Elbow	RB90SF34	RB90SF34	RB90SF34	1
Adaptor Plate	IP086100AV	IP086100AV	IP086100AV	1
Intake Gasket	IP088200AV	IP088200AV	IP088200AV	1
Grease Gun Kit	IP616200AJ	IP616200AJ	IP616200AJ	1
Grease Gun	IP616100AJ	IP616100AJ	IP616100AJ	1
Grease (80g)	IP600000AV	IP600000AV	IP600000AV	1