



BLAH1000 E

Amplifier 200-600MHz Operating & Service Manual

Version 001



The information in this manual may be altered without notice.

BRUKER accepts no responsibility for actions taken as a result of use of this manual. BRUKER accepts no liability for any mistakes contained in the manual, leading to coincidental damage, whether during installation or operation of the instrument. Unauthorised reproduction of manual contents, without written permission from the publishers, or translation into an other language, either the entire manual or a part of it, is forbidden.

This manual describes the units as they are at the date of printing. On request, the manufacturer shall supply circuit diagrams, lists of components, descriptions, calibrating instructions and any other information for use by qualified personnel of the user, in charge of repairing the parts of the unit which have been stated by the manufacturer to be "repairable". Such supply shall in no event constitute permission to modify or repair the units or approval of the same.

All rights reserved for the units, circuits, processes and appellations mentioned herein.

This unit is not designed for any type of use which is not specifically described in this manual. Such use may be hazardous.

This manual was written by

GEISSERT Bernard

© January 8, 2007: Bruker Biospin SA

Wissembourg, France

P/N: Z31789

DWG-Nr: Z4D10063

Contents

	Contents	iii
1	General information	5
1.1	Introduction	5
2	Safety	7
2.1	Labels	7
	Identifying plate	7
2.2	Safety labels and symbols	8
3	Installation	9
3.1	Initial inspection	9
	Mechanical check	9
	Claim for damage	9
	Reshipment and repackaging requirements	9
	Environment requirements	10
3.2	Installation requirements	10
	Bench operation	10
3.3	Power requirements	10
3.4	System check	10
3.5	Initial turn on procedure	11
4	Operation	13
4.1	Front Panel	13
	Indicators	13
	Coaxial Connectors	14
	Interface Connector Ethernet 10/100	14
	Device design	15
4.2	Rear Panel	16
	Rear panel supply connector	16
5	Technical description	17
5.1	System Overview	17
5.2	Theory of Operation	21
	RF Path	21
	BLA Control Board	23
	Supply Status Board	23
	Fan Status Board	23
	Status Led Board	23
	BLA Extension Board	23
	BIS Board	24

6	<i>Servicing the BLA</i>	25
6.1	Accessing the BLA amplifier	25
	Amplifier status	27
	Amplifier limitations	28
	Routing information	30
	Self-test & software reset	31
	BIS content	32
	Firmware update	33
7	<i>Specifications</i>	35
7.1	General specifications Solid output H1000	35
7.2	General specifications High Resolution output H100	36
7.3	Common Characteristics	37
8	<i>Service information and maintenance</i>	39
8.1	Preventive maintenance of the RF module on BLA-type Amplifiers	39
	Operation	39
	<i>Figures</i>	41
	<i>Tables</i>	43

General information

1

Introduction

1.1

The BLAH1000 E Amplifier is a broadband linear pulse power amplifier specifically designed for Nuclear Magnetic Resonance and Magnetic Resonance Imaging (NMR/MRI) applications from 4,7 to 14 Tesla Systems.

Operating linear class AB, it provides 1000W and more peak RF power over the frequency range 188-600MHz on the H1000 output for the Solid applications and 100W and more peak RF power on the H100 output for the High Resolution applications.

The amplifier is equipped with N-CHANNEL BROADBAND RF POWER MOS FETs of the latest generation. The unit can provide full power for any combination of pulse width and duty cycle up to 100ms and 20% (5% for the H1000 output)

Its built-in protection circuitry will allow lower power pulses for longer pulse widths and duty-cycles, maintaining a 50W average power on the H1000 output and 20W average power on the H100 output.

The electronic protection circuitry has been designed to protect against :

- Excessive power output level (overdrive)
- Excessive pulse repetition rate (over duty-cycle protection)
- Excessive pulse duration (over pulse- width)
- More than 50% reflected RF power (mismatch ≥ 6)
- Thermal protection (overheat)

The amplifier is powered by an external switched power supply assembly, housed in a 19", 2U, 500mm deep rack cabinet.

The supply is self protected for overcurrent and overvoltage.

The amplifier and supply is available under the Bruker part number W1303997.

General information



The BLAH1000 E Amplifier 200-600MHz is in accordance with the standard 61010-1 safety Requirements for Electrical Equipments.

Labels

2.1

Labels are provided to alert operating and service personnel to conditions that may cause personal injury or damage to the equipment from misuse or abuse. Please read the labels and understand their meaning.

Identifying plate

2.1.1

The BLAH1000 E Amplifier 200-600MHz can be identified by an identifying plate at the front panel of the unit that has following information.

Figure 2.1. Identifying plate

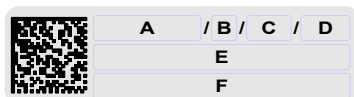

- **(A) Part Number**
This field indicates the part number of the product.
- **(B) Variant**
This field indicates the variant number that identifies the production category of the product. The default variant is 00.
- **(C) ECL**
This field indicates the revision number that identifies the product configuration. The initial revision is 0.00.
- **(D) Serial Number**
This field indicates the serial number of the product.
- **(E) Type**
This field contains the designation of the product.
- **(F) Information**
This field contains additional information about the product.



WARNING! Risk of electrical shocks

Figure 2.2. General hazard symbol



Operating personal should not remove RF output cables without turn off the power supply because the RF output power can cause serious burns before the "Mismatch" protection is active.

Please disconnect line cord before opening or prevent potential hazards such as:

- Electric shock on power supply.
- Contact burn on the RF module heatsink.
- Finger scratch due to the fan assembly on the RF module.

Installation

3

The installation of the device must be done only by an authorized and qualified technician, in total accordance with the running standards. Every breakdown due to a non-respect of the following instructions will not be attributable to Bruker and will not be covered by the guarantee clauses.

Initial inspection

3.1

Mechanical check

3.1.1

If damage of the shipping carton is evident, request the carrier's agent to be present when the instrument is unpacked. Check the equipment for damage and inspect the cabinet and panel surfaces for dents and scratches.

Claim for damage

3.1.2

If the unit is mechanically damaged or fails to meet specifications upon receipt, notify BRUKER or our representative immediately. Retain the shipping carton and packing material for the carriers inspection as well as for subsequent use in returning the unit if necessary.

Reshipment and repackaging requirements

3.1.3

Whenever possible, the original carton and packing material should be used for reshipment. If the original packing material is not available, wrap the instrument in heavy paper or plastic. Use a strong shipping container. If a cardboard is used, it should be at least 200 lbs. test material.

Use shock absorbing material around all sides of the instrument to provide a firm cushion and to prevent from movements inside the container wall on each side. Protect the front panel by means of cardboard spacers inserted between the front panel and the shipping carton. Make sure that the instrument cannot move in the container during shipping. Seal the carton with a good grade of shipping tape and mark the container :

" FRAGILE ELECTRONIC INSTRUMENT."

Installation

Environment requirements

3.1.4

This amplifier is build for inside use only on a maximum high level of 2000m above sea level (6600 feet).

No specific cooling or ventilation is required.

Be sure that the amplifier has enough area around so that the free air flow into and out of the amplifier is not obstruct.

It should, however, be in an environment which conforms to the 5°C - 45°C (41°F - 113°F) thermal specifications, a 80% maximum relative humidity of air and a contamination level of 2 (means a normal only non conductive contamination, temporary conductivity due to condensation is possible).

Installation requirements

3.2

No special precautions are necessary. Mount the equipment in an area which is relatively free of vibration, and has sufficient room for cable connections.

The amplifier is a class II of installation category.

Bench operation

3.2.1

The unit can be placed onto a secure flat surface.

Power requirements

3.3

The BLAH1000 E is designed to be powered by an additional switched power supply (BRUKER part number W1304007).

The connection to this power supply is realized via a 500mm cable fitted with a 15 pins DIN 41612-ERNI female connector and coming out from the rear panel of the amplifier.

This switched power supply provides all the voltages necessary to the BLAH1000 E (5 x +32V / +15V / -15V / +3,3V / GND)

System check

3.4

Before applying power for the first time the following items should be checked:

- The AC input voltage 220-230 VAC \pm 15% range must be compatible with the power supply.
- An external blanking (gating) pulse must be supplied to the amplifier in order the unit to function. Ensure that this pulse has a proper level and logic polarity.
- The BLAH1000 E has a nominal input level of +4dBm. Ensure that the system drivers are operating at these levels.

Initial turn on procedure**3.5**

The following list describes how to turn on the BLAH1000 E and what should be seen as this occurs.

Before starting this procedure, make sure that you have properly followed instructions in the section **"System check" on page 10.**

1. Connect the AC line to the power supply and set the power switch to the ON position.
2. Observe the indicators on the front panel of the amplifier :
 - The +32V ON LED's will illuminate,
 - The +15V, -15V and +3,3V ON LED's will illuminate.
3. System is now fully operational.

Operation

4

Front Panel

4.1

The BLAH1000 E front panel is provided with 12 indicators for status monitoring, 7 RF connectors, and 1 interface connector.

Indicators

4.1.1

Normal operation is indicated when following LED's are ON.

Table 4.1. Indicators assignment

+32V	Indicates that the 5 x +32V supplies are applied.
+15V	Indicates that the +15V supply is applied.
-15V	Indicates that the -15V supply is applied.
+3,3V	Indicates that the +3,3V supply is applied.
Overdrive	Indicates when the peak power limit has been reached.
Duty Cycle (D.C.)	Indicates when the duty cycle limit has been reached.
Pulse Width (P.W.)	Indicates when the pulse width limit has been reached.
Mismatch	Indicates when the max. reflected power limit has been reached.
RF POW. FLT	Indicates when one of the above limits has been reached.
Overheat	Indicates that the thermistor located on the RF module heatsink has sensed excessive heatsink temperature. The amplifier is blanked until an acceptable temperature is reached. The function is self-resetting and no maintenance is needed. Indicates also that a fan on the assembly stops turning. The amplifier is blanked until fans are changed.
H1000	Indicates when the RF Power is present on the Solid output.
H100	Indicates when the RF Power is present on the High Resolution output.

Table 4.2. Coaxial Connectors assignment

IN1, IN2, IN3	RF inputs of the embedded router, SMA type connector (female). Default entry is IN1 and allows to the BLAH1000 E to deliver full power at nominal +4dBm drive.
H1000	RF OUT H1000 (Solid output) N type connector (female).
H100	RF OUT H100 (High Resolution) N type connector (female).
BLNK	BNC type connector (female). TTL logic, 5V = blanking ON, 0V = blanking OFF. When BLANKING signal is at TTL level high (+5V), no gating is applied to the amplifier stages, and no RF Power is possible. When BLANKING signal is at TTL level low (0V), the amplifier stages are gated and RF Power is possible.
SEL H1000/H100	BNC type connector (female). When the SELH1000/H100 signal is at TTL level low (0V), the Solid output H1000 is selected. When the SELH1000/H100 signal is at TTL level high (5V), the High Resolution output H100 is selected.

The RJ45 connector for the Ethernet 10/100 Mbps link is mounted directly on the BLA Control Board.

Table 4.3. RJ45 Pin assignment

Pin 1	Transmit + (Tx+)
Pin 2	Transmit - (Tx-)
Pin 3	Receive + (Rx+)
Pin 4	N/A
Pin 5	N/A
Pin 6	Receive - (Rx-)
Pin 7	N/A
Pin 8	N/A

Figure 4.1. BLAH1000 E Front Panel Design

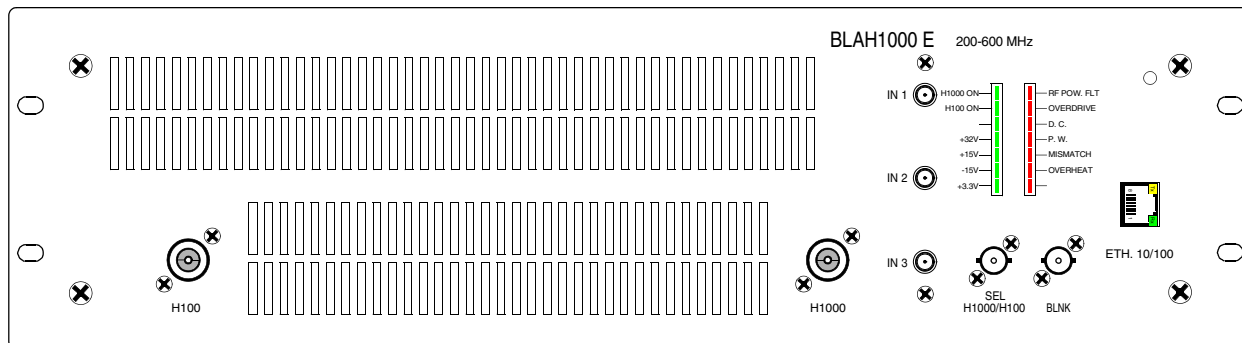
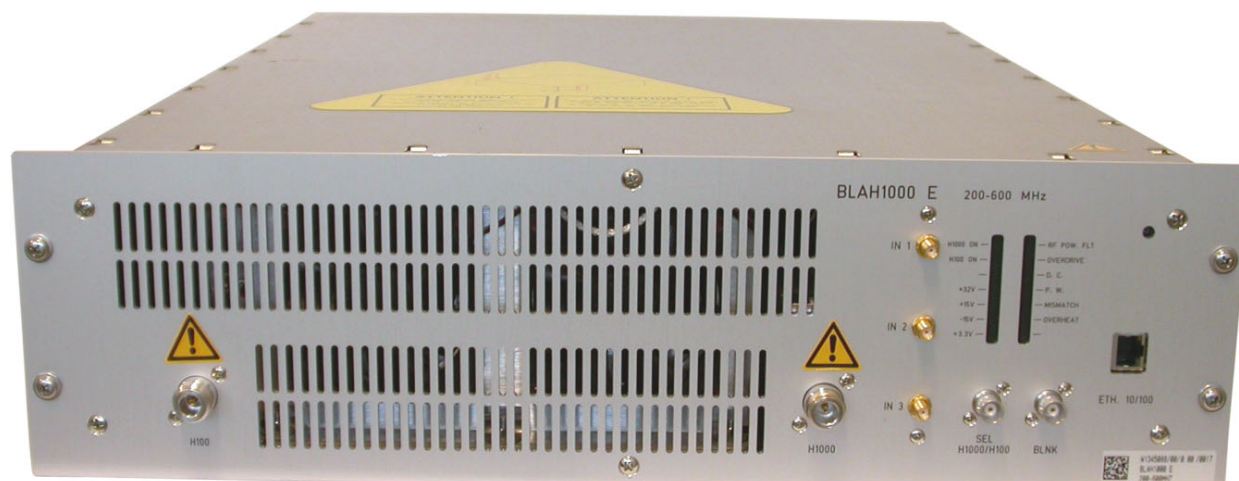

Figure 4.2. BLAH1000 E Front Panel View



Rear Panel

4.2

The rear Panel of the BLAH1000 E Amplifier has a 500mm cable fitted with a 15 pin DIN 41612-ERNI female connector, coming out of the rear panel of the amplifier.

Rear panel supply connector

4.2.1

Table 4.4. DIN 41612-ERNI Pin assignment

Pin z4	+3,3V	Pin d6	not connected
Pin z8	+15V	Pin d10	DGND
Pin z12	-15V	Pin d14	PGND
Pin z16	+32V	Pin d18	PGND
Pin z20	+32V	Pin d22	PGND
Pin z24	+32V	Pin d26	PGND
Pin z28	+32V	Pin d30	PGND
Pin z32	+32V		

Note

DGND = Digital Ground for $\pm 15V$ and $+3,3V$

PGND = Power Ground for 5 x $+32V$

Figure 4.3. BLAH1000 E Rear View

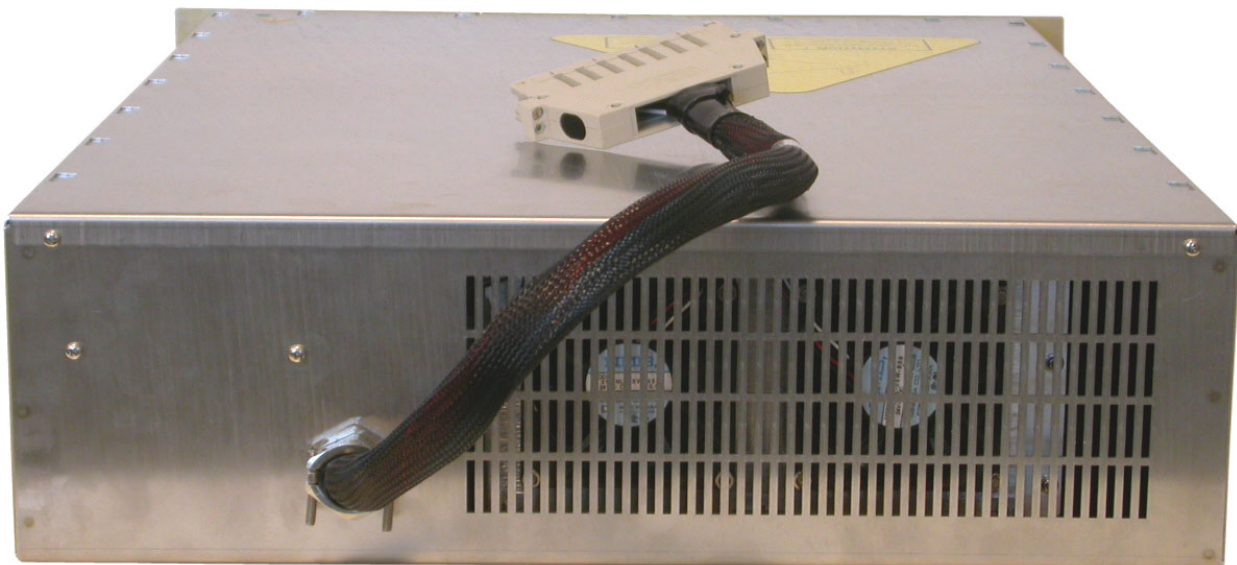

The BLAH1000 E amplifier requires the additional Bruker Power Supply P/N : W1304007, to provide :

- A RF Output of 1000W and more on the Solid Output H1000, over the full frequency range 188 to 600MHz, when selected for Solid operation with SELH1000/H100 command controlled at TTL level low.
- A RF Output of 100W and more on the High Resolution Output H100, over the full frequency range 188 to 600MHz, when selected for High Resolution operation with SELH1000/H100 command controlled at TTL level High.

The RF section of the system consists of an embedded router fixed on the front panel and a linear module BLMH1000-E mounted around a single, self-contained Push and Pull fan assemblies, heatsink.

The embedded router has three RF inputs and one RF output feeded to the driver amplifier.

A linear class A / AB driver using switches and bias voltage gatings, delivers the RF input power to the four Power Amplifiers, through a 4 ways in-phase splitter.

The driver is located on the bottom of the heatsink assembly. The power splitter is located on the top of the heatsink assembly.

Four class AB power amplifiers, located on the top and the bottom of the heatsink are combined by mean of a 4 ways in-phase combiner. It is located between the heatsink assembly and the lateral right side of the case.

The output of the combiner is connected to a bi-directional high dynamic coupler mounted on the front panel of the amplifier. This output will be the Solid H1000 Output when the amplifier is controlled for Solid applications.

When controlled for High Resolution applications, the output of the driver is switched to the front panel H100 output via a RF relay and a bi-directional high dynamic coupler. The entire system is controlled by a Digital Signal Processing control board, processing information from the amplifier and blanking signal, providing protection from excessive peak power, duty cycle and pulse width for average power, maximum reflected power and heatsink over-temperature.

The DSP Control Board reads the identification information of the amplifier (BIS).

Circuits such, Fan Status board, Supply Status board and LED's Status board, complete the amplifier assembly.

Technical description

Figure 5.1. BLAH1000 E System Block Diagram

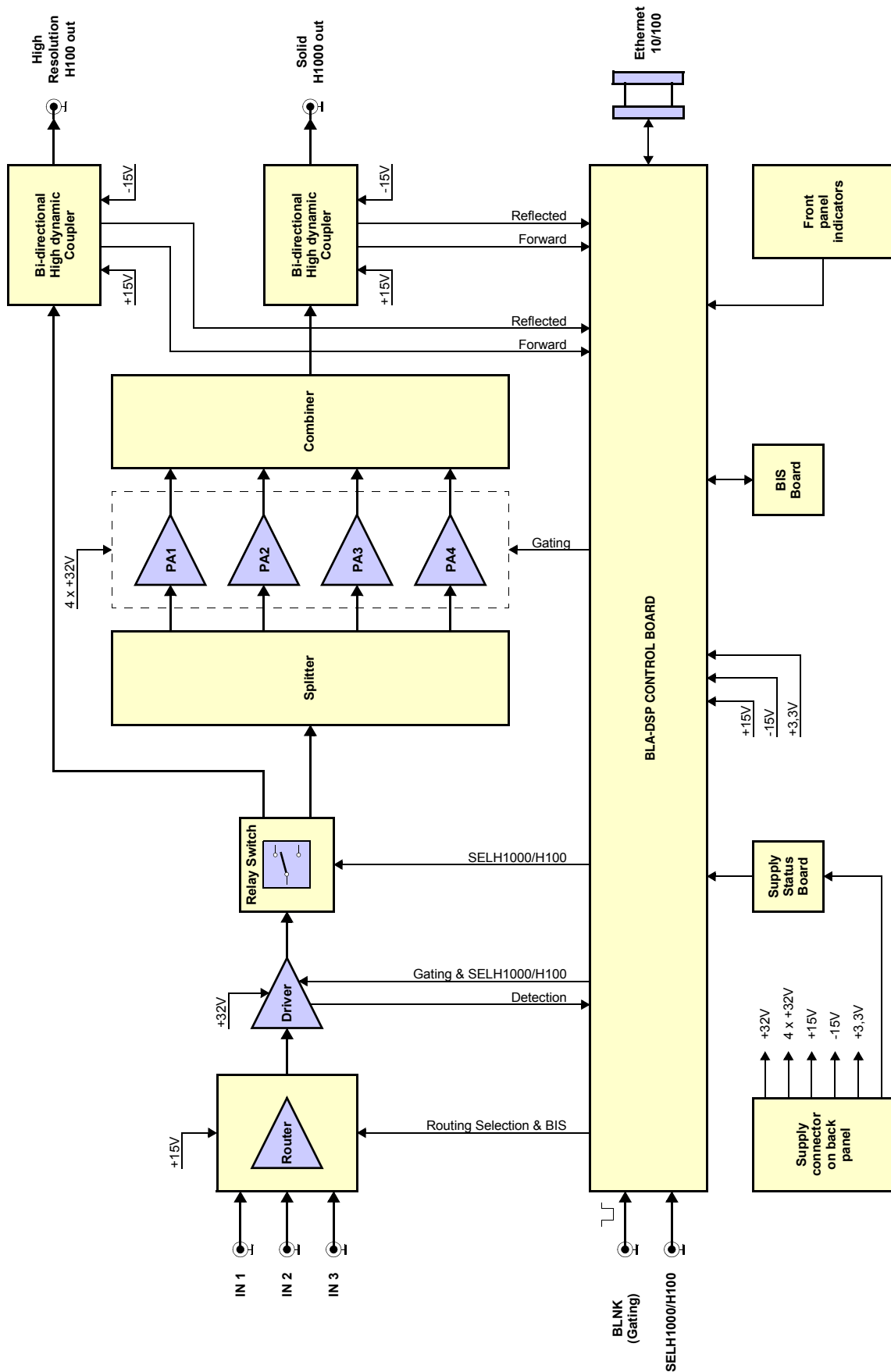

Figure 5.2. Embedded router Block Diagram

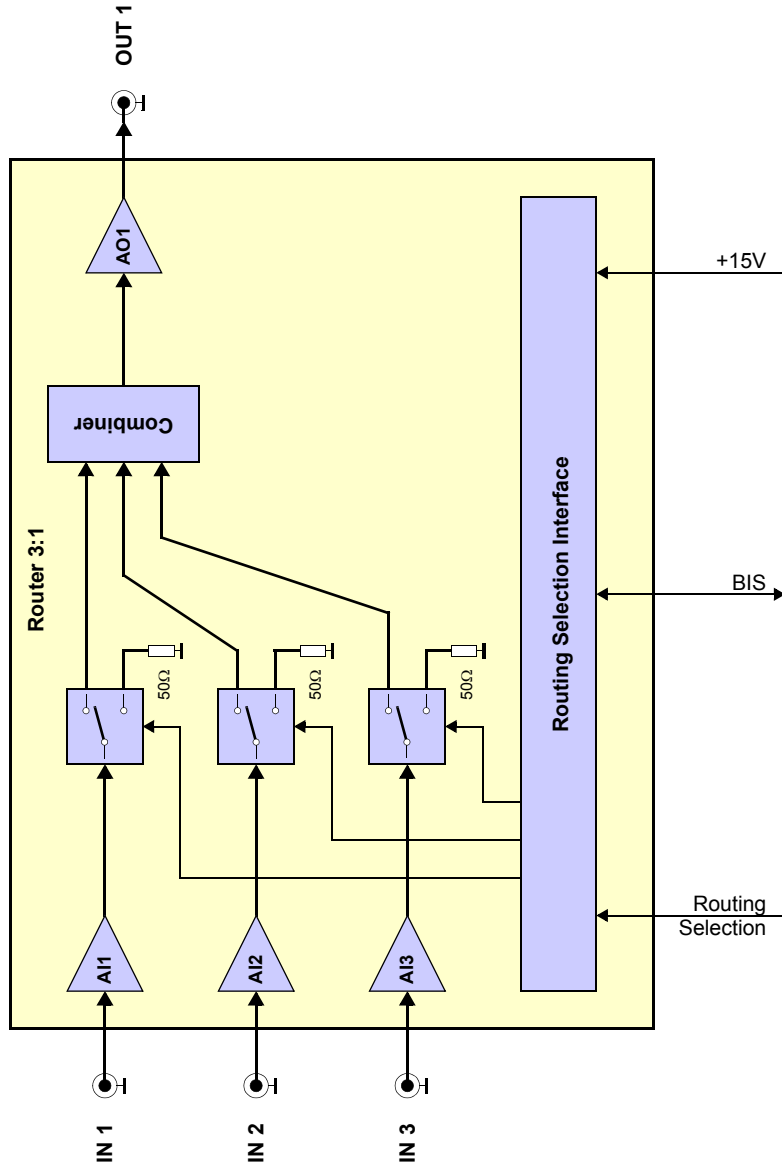
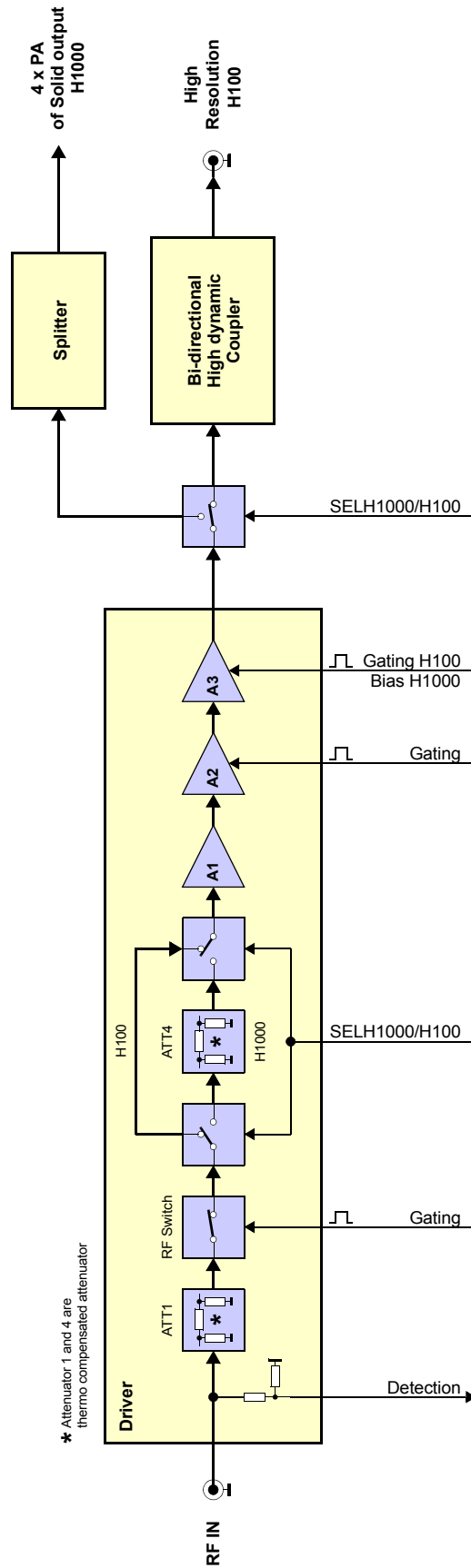

Figure 5.3. Driver Block Diagram



Theory of Operation**5.2**

RF Path**5.2.1**

The BLAH1000 E (P/N : W1345088) amplifier consists of a 3 input embedded Router, a Class A / AB driver amplifier and a Class AB power amplifier.

A nominal input power level of +4dBm produces a rated linear output power of :

- 100W peak for 20% duty cycle at 100ms pulse width maximum on the High Resolution output H100, when selected as High Resolution amplifier.
In this case the 100W driver is directly switched to the front panel via a mechanical relay and a bi-directional high dynamic coupler.
- 1000W peak for 5% duty-cycle at 100ms pulse width maximum on the Solid output H1000, when selected as a Solid amplifier.
In this case the output of the 100W driver is switched to the input of the four output power amplifiers via the mechanical switch and a 4 ways power splitter.

The unit is also capable of longer pulses for lower average power, up to 50W CW Power on the Solid output H1000 (20W CW on the High Resolution output H100).

Embedded Router

The embedded Router consists of a Class A RF amplifier IC's and RF switches, manufactured on a Gallium Arsenide process.

It is built on a four independent cells architecture with three RF input cells and one RF output cell. The RF input cell ensures function of amplification and routing, the output cell ensures the function of combining, RF amplitude thermo-stability and amplification.

The three RF inputs could be routed alone or combined each other to the RF output by selecting the wished RF path through the BLA controller board. Each entire RF path has a nominal 15dB of gain and operates at +15V DC.

Also, the router is equipped with a EEPROM for BIS information.

RF Driver

In the first section of the driver, the RF input signal is fed through the RF detection path to a thermo-compensated attenuator. Then, via an AsGa RF Switch and a commutable H1000/H100 attenuator, the RF signal is conveyed to a hybrid amplifier.

The commutable H1000/H100 attenuator minimizes the gain of this section of about 3dB by a thermo-compensated attenuator when the amplifier is operating on the Solid H1000 Output.

In this section, only the AsGa RF Switch requires a control board conditioned gating signal to control the operation of the switching element.

The second section of the driver includes two stages of MOS FET Transistors.

The circuitry around the transistors consists of complementary input and output transformers and baluns and operates the devices in push-pull.

This section requires a control board conditioned gating signal to control the bias voltage on the gates of the FETs.

The entire RF driver has a nominal 50dB gain, able to develop more than 100W linear power, and operates at +32V DC.

RF Relay H1000/H100

The coaxial RF relay switches the RF Power from the driver via a bi-directional high dynamic coupler to the High Resolution output H100 on the front panel, when the SELH1000/H100 signal is controlled to TTL level high or not connected.

When controlled by SELH1000/H100 signal at TTL low, the relay switches the output of the driver to the 4 Power Amplifiers via a 4 ways in-phase splitter, to built the Solid output H1000.

RF Coupler H100

The H100 bi-directional high dynamic coupler provides an approximate 1V peak DC signal for full 100W and also a peak DC signal for reflected power on the High Resolution output H100.

Both signals, forward and reflected, are analyzed by the BLA control board for monitoring and protection setting on the H100 output.

RF Splitter

The RF Splitter acts as a 4 ways in-phase splitter between the output of the RF driver and the inputs of the 4 power amplifiers PA. All the wiring around this splitter are made with 50Ω coaxial cables equipped with SMA connectors.

RF Power Amplifier

Each of the four PA includes four FET transistors mounted on a single flange. The circuitry around each transistor consists of complementary input and output transformers and baluns and operates the devices in push-pull. The RF input signal is splitted to each transistor via a microstrip splitter. The RF output signal from each transistor is combined by a microstrip combiner. The four PA requires a control board conditioned gating signal in order to control the bias gate voltage on the gates of the FETs.

The four PA operates at +32V DC and are followed by an in-phase combiner.

RF Combiner

The RF Combiner acts as an 4 ways in-phase combiner between the outputs of the four PA and the input of the bi-directional high dynamic coupler mounted on the front panel of the BLAH1000 E amplifier. All wiring around this combiner are made with 50Ω coaxial cables mounted on SMA and N connectors.

RF Coupler H1000

The H1000 bi-directional high dynamic coupler on the front panel provides an approximate 1V peak DC signal for full 1000W and also a peak DC signal for reflected power on the Solid output H1000.

Both signals, forward and reflected, are analyzed by the BLA Control board for monitoring and protection setting on the H1000 output.

BLA Control Board

5.2.2

The BLA Control Board has 3 functions:

- Monitor the output characteristics of the amplifier. This is done thanks to the DC peak detections of the bi-directional high dynamic couplers.
- Condition the input blanking (BLNK) signal. The board delivers it to the above mentioned RF Paths.
- Allow Ethernet communication with the workstation.

The monitoring circuitry is also useful to process the detection information and protect the amplifier from overstress in peak power, average power versus duty cycle and pulse width, so as excess of reflected power.

The control board also monitors the RF Path heatsink temperature to protect against thermal overstress.

Information from supplies and fan status board are also analyzed by the control board.

If one of the above overstresses, faults on power supplies or fans appears, the gating signal is disabled, and the status led board on the front panel displays the fault.

Supply Status Board

5.2.3

This board gives the information of the status from the power supply.

A defect on one or more of the supplies is read by the control board, and in case of, the gating signal is disabled while the defect is visualized on the front panel led display.

Fan Status Board

5.2.4

The fan status board gives information of the status of the two push and pull fan assemblies. A defect on the fans is read by the control board, the gating signal is disabled, and the "overheat" led of the front panel Status led display lights ON.

Status Led Board

5.2.5

The Status Led Board, on the front panel of the amplifier, displays overstress functions, supplies status, and so on, as described in "[Indicators](#)" on page 13 and "[BLA Control Board](#)".

BLA Extension Board

5.2.6

This board gives the information to the control board of RF detection.

The universal BIS board is located on the amplifier case and contains identifications of the amplifier.



Technical help : please contact your local representative.

Servicing the BLA

6

Diagnosis and servicing access to the BLA amplifier relies on HTTP, allowing service access with any web browser.

Accessing the BLA amplifier

6.1

The BLAH1000 E Amplifier 200-600MHz is accessible via the BLA control board with its IP address.

The IP address is given during "cf" by using TOPSPIN 2.xx software on the workstation.

In case of problems :

- Check the RJ45 cabling between amplifier, Ethernet switch and workstation.
- Check the Ethernet switch power.
- Check if the green LED on the amplifier RJ45 connector lights up.
- Check the front panel of the amplifier, LED's indicators +32V, +15V, -15V and +3.3V ON must have lit.

To access the BLAH1000 E Amplifier 200-600MHz, type "ha" in TOPSPIN 2.xx and choose the BLA that should be accessed or start your favourite web browser and type the given IP address as URL.

You should get the following start screen.

Servicing the BLA

Figure 6.1. Device Information

BRUKER BLA Service Web

Bruker Linear Amplifier
Device Information

Amplifier Information

- Amplifier status
- Amplifier limitations
- Routing information
- Self test & Software reset
- BIS content
- Firmware update

Name: BLAH1000 E 200-600MHZ
Part number: W1345088
Serial number: 0001
Ecl: 0
Manufacturing location: BFR
Manufacturing date: 10/19/06
BIS type: BLA

Software versions

Boot version: 20051018
Kernel version: Windows CE 5.0
Application version: 20060727

Channel Information

Ch.	Type	Nom. power	Min freq.	Max freq.	Limits			Forw. peak	Output num.	Input num.
					Duty cycle	Pulse width	Mismatch			
1	H	1000 W	180 MHz	600 MHz	5 %	100 ms	500 W (50 %)	2000 W (200 %)	1	Via router

High Resolution Option Information

Ch.	Nom. power	Limits			Output num.
		Duty cycle	Pulse width	Mismatch	
1	100 W	20 %	100 ms	50 W (50 %)	2

© 2005 Bruker Biospin SA. All rights reserved.

The left panel is the navigation menu. It can be used to navigate through the service pages.

Amplifier status

6.1.1

Leads you to a page giving information about the current status from the selected channel of the amplifier.

Figure 6.2. Amplifier status (High Resolution and Solide)

BRUKER BLA Service Web

Bruker Linear Amplifier
Amplifier status

Amplifier information	Name: BLAH1000 E 200-600MHZ
Amplifier status	Part number: W1345088
Amplifier limitations	Serial number: 0001
Routing information	Ecl: 0
Self test & Software reset	Channel 1 (HR)
BIS content	Type : H
Firmware update	Nominal power : 100 W
	Forward peak power : 0.00 %
	Forward average power : 0.00 %
	Reflected power : 0 %
	Overdrive : OK
	Pulse width : OK
	Duty cycle : OK
	Mismatch : OK
	General gating fault : OK
	Supply : OK
	Thermal : OK
	Blanking signal state : inactive
	Input power : none
	Output power : none
	High resolution state : active
	Switchbox position : 0xFF

This page is automatically refreshed every 10 seconds

© 2005 Bruker Biospin SA. All rights reserved.

BRUKER BLA Service Web

Bruker Linear Amplifier
Amplifier status

Amplifier information	Name: BLAH1000 E 200-600MHZ
Amplifier status	Part number: W1345088
Amplifier limitations	Serial number: 0001
Routing information	Ecl: 0
Self test & Software reset	Channel 1
BIS content	Type : H
Firmware update	Nominal power : 1000 W
	Forward peak power : 0.00 %
	Forward average power : 0.00 %
	Reflected power : 0 %
	Overdrive : OK
	Pulse width : OK
	Duty cycle : OK
	Mismatch : OK
	General gating fault : OK
	Supply : OK
	Thermal : OK
	Blanking signal state : inactive
	Input power : none
	Output power : none
	High resolution state : inactive
	Switchbox position : 0xFF

This page is automatically refreshed every 10 seconds

© 2005 Bruker Biospin SA. All rights reserved.

Leads you to a page giving several, default and current limits, from the selected channel of the amplifier.

Figure 6.3. Amplifier limitations (High Resolution and Solide)

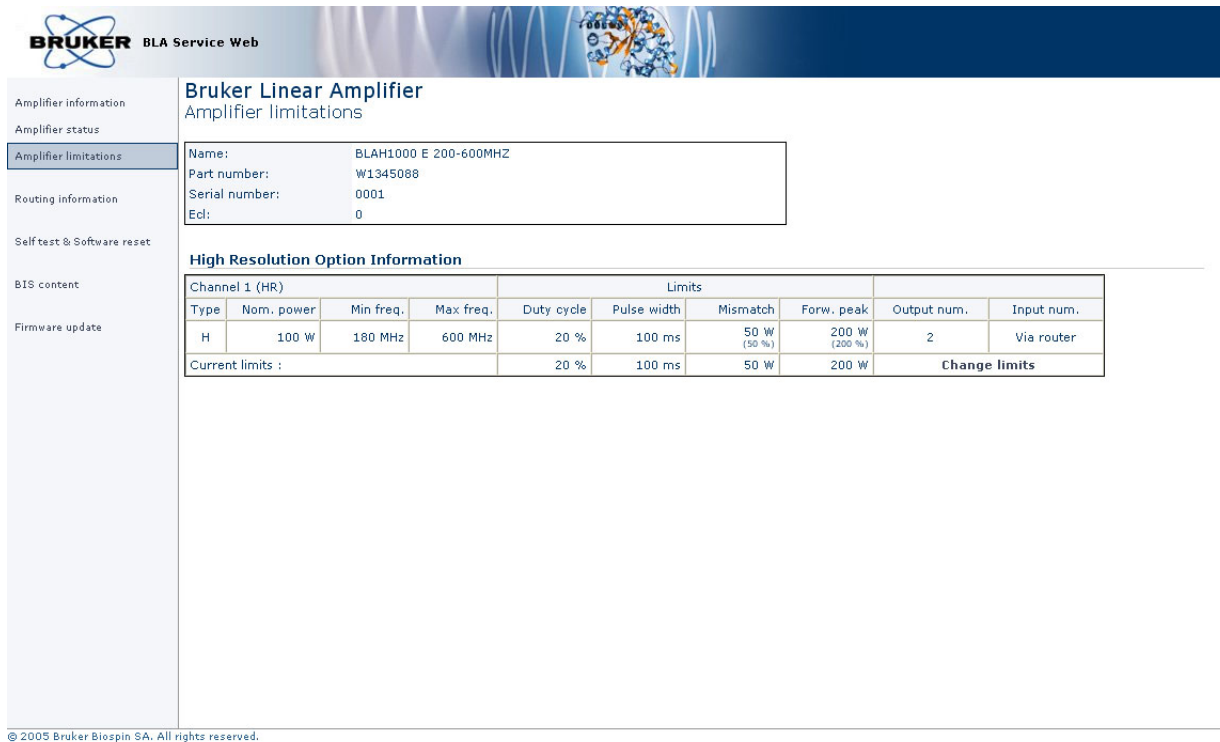

BRUKER BLA Service Web

Bruker Linear Amplifier
Amplifier limitations

Amplifier information
Amplifier status
Amplifier limitations
Routing information
Self test & Software reset
BIS content
Firmware update

Name: BLAH1000 E 200-600MHZ
Part number: W1345088
Serial number: 0001
Ecl: 0

High Resolution Option Information

Channel 1 (HR)				Limits				Output num.	Input num.
Type	Nom. power	Min freq.	Max freq.	Duty cycle	Pulse width	Mismatch	Forw. peak		
H	100 W	180 MHz	600 MHz	20 %	100 ms	50 W (50 %)	200 W (200 %)	2	Via router
Current limits :				20 %	100 ms	50 W	200 W	Change limits	

© 2005 Bruker Biospin SA. All rights reserved.

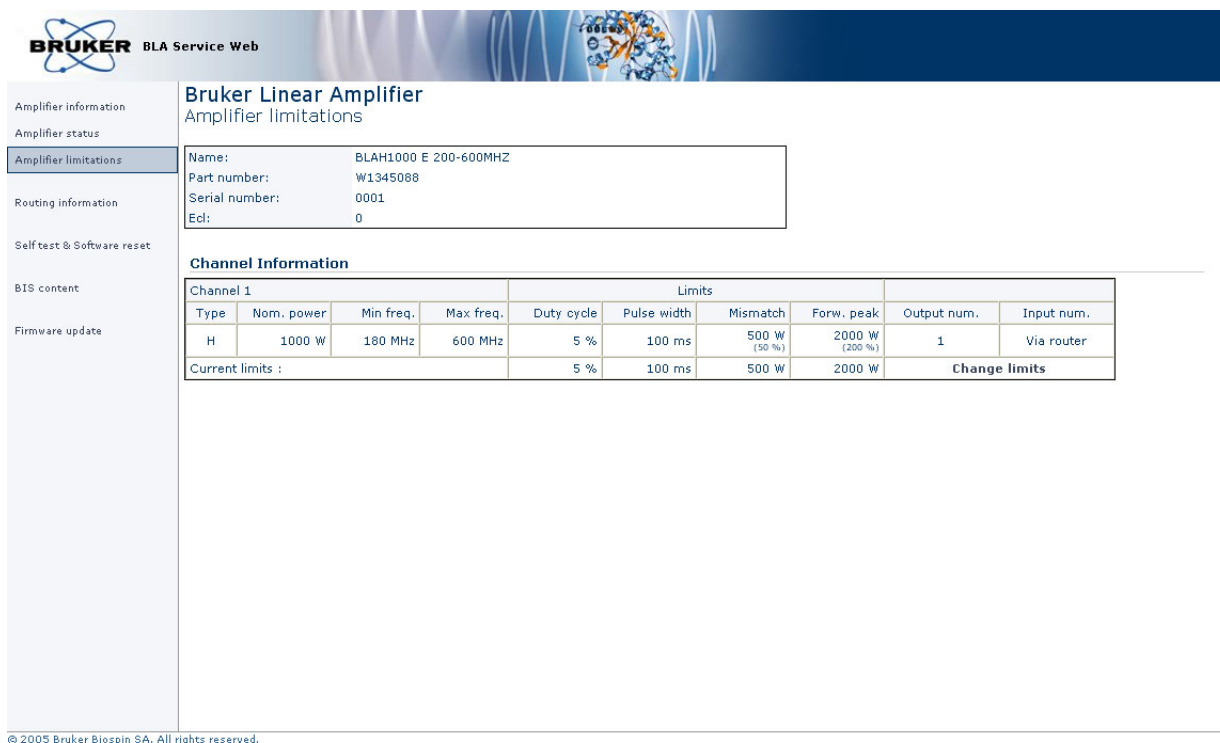

BRUKER BLA Service Web

Bruker Linear Amplifier
Amplifier limitations

Amplifier information
Amplifier status
Amplifier limitations
Routing information
Self test & Software reset
BIS content
Firmware update

Name: BLAH1000 E 200-600MHZ
Part number: W1345088
Serial number: 0001
Ecl: 0

Channel Information

Channel 1				Limits				Output num.	Input num.
Type	Nom. power	Min freq.	Max freq.	Duty cycle	Pulse width	Mismatch	Forw. peak		
H	1000 W	180 MHz	600 MHz	5 %	100 ms	500 W (50 %)	2000 W (200 %)	1	Via router
Current limits :				5 %	100 ms	500 W	2000 W	Change limits	

© 2005 Bruker Biospin SA. All rights reserved.

If you want, for any reasons, to change the current limits from the selected channel of the amplifier, press **Change limits**.

Figure 6.4. Change limits (High Resolution and Solide)

BRUKER BLA Service Web

Bruker Linear Amplifier
Channel limitations

Amplifier information
Amplifier status
Amplifier limitations
Routing information
Self test & Software reset
BIS content
Firmware update

Name: BLAH1000 E 200-600MHZ
Part number: W1345088
Serial number: 0001
Ecl: 0

High Resolution Option Limitations
Warning : Changing these settings will overwrite the limitations defined with the spectrometer software. Please use this page for test purposes only.

Type :	H			
Nominal power :	100 W			
	Default	Current	New	Maximum
Duty cycle limit :	20 %	20 %	<input type="text" value="20"/> %	20 %
Pulse width limit :	100 ms	100 ms	<input type="text" value="100"/> ms	100 ms
Mismatch limit :	50 W (50 %)	50 W	<input type="text" value="50"/> W	100 W
Forward peak limit :	200 W (200 %)	200 W	<input type="text" value="200"/> W	200 W
			<input type="button" value="Apply"/>	
Output number :	2			
Input number :	Via router			

© 2005 Bruker Biospin SA. All rights reserved.

BRUKER BLA Service Web

Bruker Linear Amplifier
Channel limitations

Amplifier information
Amplifier status
Amplifier limitations
Routing information
Self test & Software reset
BIS content
Firmware update

Name: BLAH1000 E 200-600MHZ
Part number: W1345088
Serial number: 0001
Ecl: 0

Channel 1 limitations
Warning : Changing these settings will overwrite the limitations defined with the spectrometer software. Please use this page for test purposes only.

Type :	H			
Nominal power :	1000 W			
Min. frequency :	180 MHz			
Max. frequency :	600 MHz			
	Default	Current	New	Maximum
Duty cycle limit :	5 %	5 %	<input type="text" value="5"/> %	5 %
Pulse width limit :	100 ms	100 ms	<input type="text" value="100"/> ms	100 ms
Mismatch limit :	500 W (50 %)	500 W	<input type="text" value="500"/> W	1000 W
Forward peak limit :	2000 W (200 %)	2000 W	<input type="text" value="2000"/> W	2000 W
			<input type="button" value="Apply"/>	
Output number :	1			
Input number :	Via router			

© 2005 Bruker Biospin SA. All rights reserved.

Read the warnings, change limit parameters and press **Apply** if you are sure of that.

Leads you to a page giving information about the current routed RF path at the amplifier inputs.

Default RF path is INPUT 1 to CHANNEL1

Figure 6.5. Routing information

The screenshot shows the Bruker BLA Service Web interface. On the left is a navigation menu with options: Amplifier information, Amplifier status, Amplifier limitations, Routing information (highlighted), Self test & Software reset, BIS content, and Firmware update. The main content area is titled 'Bruker Linear Amplifier Routing Information & Setting'. It contains a form with the following fields: Name: BLAH1000 E 200-600MHZ, Part number: W1345088, Serial number: 0001, and Ecl: 0. Below this is a red warning message: 'Warning : Changing these settings will overwrite the routes defined with the spectrometer software. Please use this page for test purposes only.' At the bottom is a table with columns: Input number, Current channel, Possible channels, and New route. The table has three rows. The first row shows Input number 1, Current channel 1, Possible channels 1, and New route 'Channel 1' with a 'set new route' button. The second row shows Input number 2, Current channel 0, Possible channels 1, and New route 'no route' with a 'set new route' button. The third row shows Input number 3, Current channel 0, Possible channels 1, and New route 'no route' with a 'set new route' button. The footer of the page reads '© 2005 Bruker Biospin SA. All rights reserved.'

Input number	Current channel	Possible channels	New route
1	1	1	Channel 1 <input type="button" value="set new route"/>
2	0	1	no route <input type="button" value="set new route"/>
3	0	1	no route <input type="button" value="set new route"/>

Read the warnings, it is allowed to change routing configuration (ex: new route INPUT 2 to CHANNEL1), press **Set new route** if you are sure of that.

Leads you to a page allowing you to do a self-test on the BLA control board (Hardware test) and to do a software reset.

Both operations can be done if the amplifier doesn't work correctly.

Figure 6.6. Self-test, software reset and report

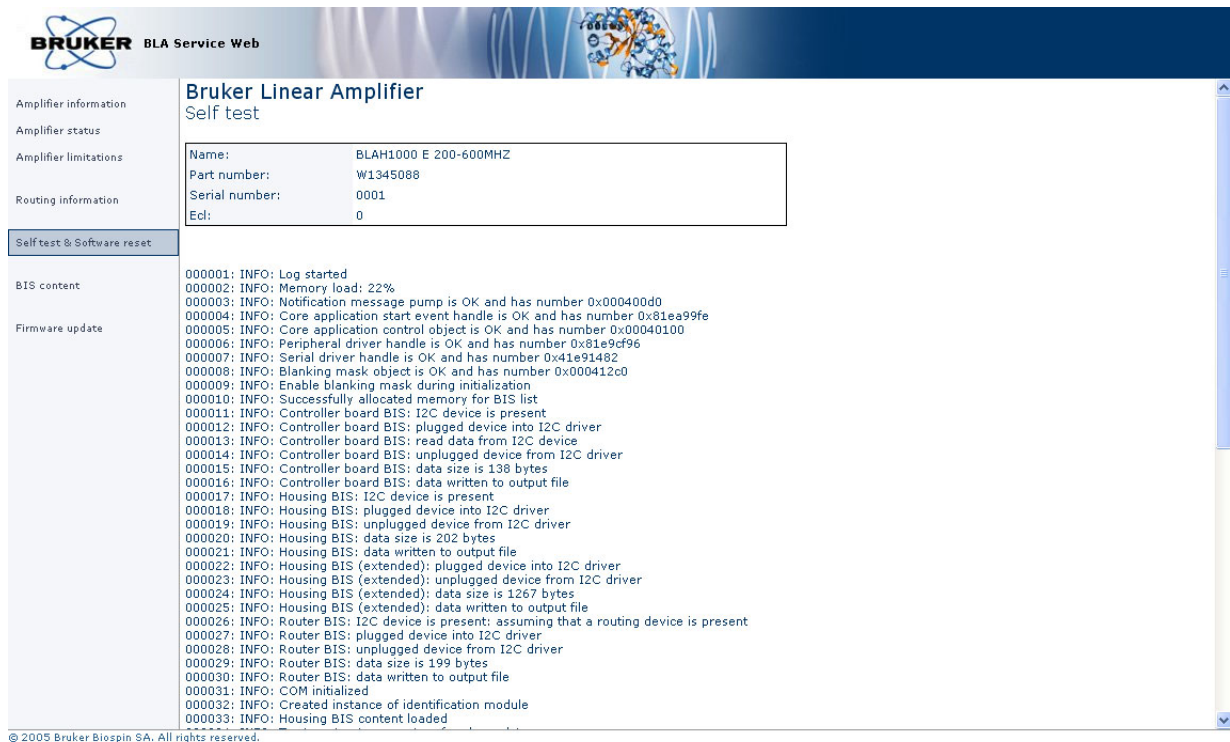
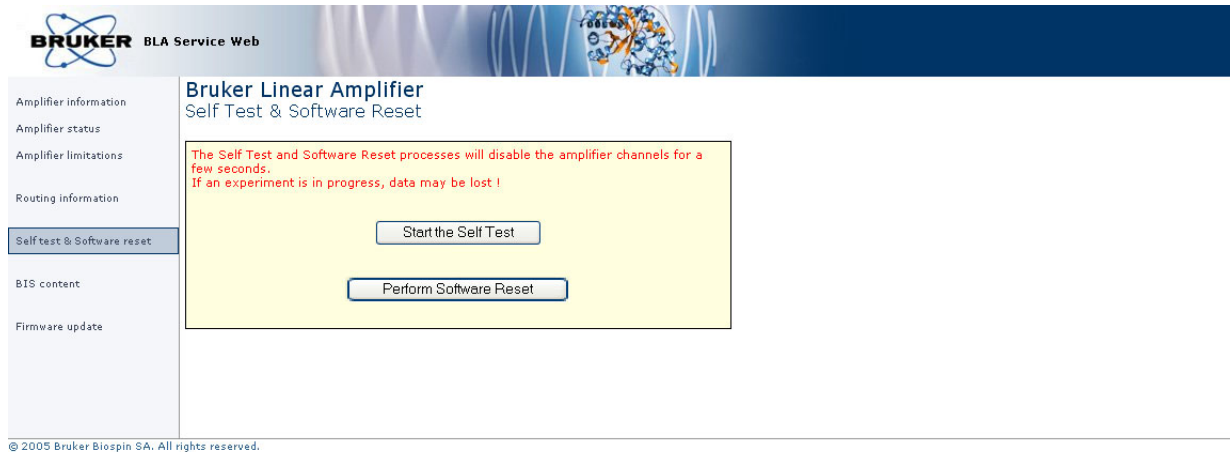

Read the warnings, press **Start the self-test**.

You should have only blue lines in the report .

Leads you to a page giving information about the current BIS programmed on the amplifier.

Figure 6.7. BIS content

Bruker Linear Amplifier BIS Content	
BIS Id:	1
BIS description:	BLA Controller
BIS type:	BLAC
BIS content:	<pre> \$Bis,1,20060210,2048,BLAC,1# \$Prd,W1522040,0000,0,,BFR,20060210# \$Nam,BLA CONTROL BOARD 6.2V V-USB# \$CtrlVers,1.0,6.0# \$EndBis,c9, 20# </pre>
BIS Id:	2
BIS description:	BLA Housing
BIS type:	BLA
BIS content:	<pre> \$Bis,1,20061019,2048,BLA,3# \$Prd,W1345088,0001,0,,BFR,20061019# \$Nam,BLAH1000 E 200-600MHZ# \$Amp,1.1,1,H,,1000,F8,5,100,180,600,1,0,50,200,200,# \$HR Opt,1.0,1,,100,20,100,180,600,2,50,200,200# \$EndBis,d8, 69# </pre>
BIS Id:	3
BIS description:	Mini-Router
BIS type:	BLAROUTER
BIS content:	<pre> \$Bis,1,20061019,2048,BLAROUTER,1# \$Prd,W1345212,0010,0,,BFR,20061019# \$Nam,BLMR31 RF AMPLIFIER MODULE# \$RtnChar,1.0,10,1000,15# \$RtnPath,1.0,1,1,1# \$RtnPath,1.0,2,1,1# \$RtnPath,1.0,3,1,1# \$EndBis,50, 14# </pre>

© 2005 Bruker Biospin SA. All rights reserved.

Leads you to a page allowing you to download new firmware.

Figure 6.8. Firmware update

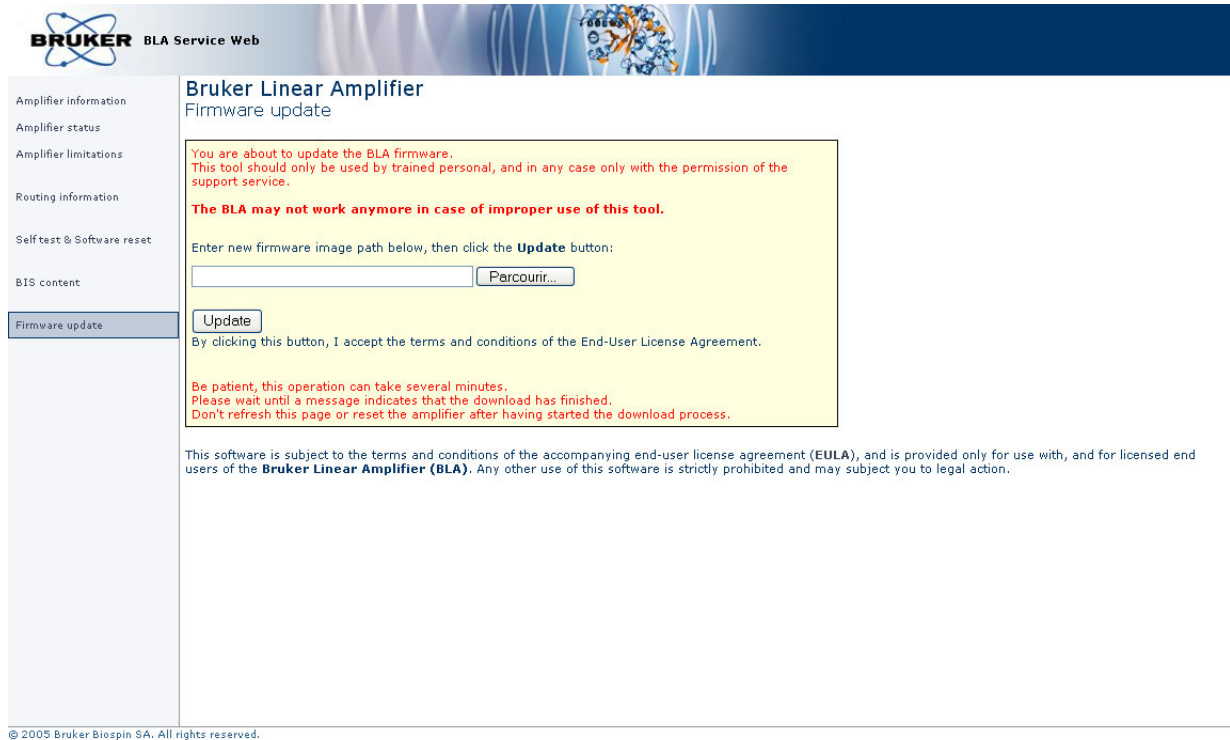

Read the warnings, press the Browse button for selecting the new firmware file to download and press **Update**. Download the new firmware will take a few minutes.



NOTE : This button caption depends on your operating system language settings

Specifications

7

General specifications Solid output H1000

7.1

Table 7.1. BLAH1000 E Solid Output H1000 Specifications

Frequency range	180 to 600MHz
Linear Gain	59dB \pm 1dB typical
Gain Flatness	\pm 4dB max.
Minimum Pulsed Output Power	1000W min. full range (@ nominal input +4dBm)
CW Output Power (internal limitation)	50W max.
Linear Output Power	800W typical @ 1dB Compression
Linearity	\pm 1dB to 800W typical
Amplifier Biasing	Class AB Operation
Blanking Delay Time	1 μ s min.
RF Rise Time	< 100ns
RF Fall Time	< 50ns
DC Ringing	\pm 200mV typical (due to blanking signal)
Input Noise Figure	10dB typical
Output Noise Power (Unblanked)	-105dBm @ 1Hz
Output Noise Power (Blanked)	< 25dB over Thermal Noise
Input/output Impedance	50 Ω
Input V.S.W.R. Route OFF	1.2 max.
Input V.S.W.R. Route ON	1.3 max.
Output Harmonics (2fc ; 3fc)	-40dBc ; -20dBc max. @ 1000W
Pulse Width (internal limitation)	100ms @ 1000W (up to CW @ 50W)
Duty Cycle (internal limitation)	5% @ 1000W (up to 100% @ 50W)
Droop & Pulse Flatness	\pm 4% typical @ 1000W for 100ms PW
Amplitude Stability vs. Temperature	\pm 0,2% / $^{\circ}$ C max.

Table 7.2. BLAH1000 E High Resolution Output H100 Specifications

Frequency range	180 to 600MHz
Linear Gain	50dB ±1dB typical
Gain Flatness	± 2dB max.
Minimum Pulsed Output Power	100W min. full range (@ nominal input +4dBm)
CW Output Power (internal limitation)	20W max.
Linear Output Power	80W typical @ 1dB Compression
Linearity	± 1dB to 80W typical
Amplifier Biasing	Class AB Operation
Blanking Delay Time	1µs min.
RF Rise Time	< 100ns
RF Fall Time	< 50ns
DC Ringing	± 200mV typical (due to blanking signal)
Input Noise Figure	9dB typical
Output Noise Power (Unblanked)	-114dBm @ 1Hz
Output Noise Power (Blanked)	Thermal Noise
Input/output Impedance	50Ω
Input V.S.W.R. Route OFF	1.2 max.
Input V.S.W.R. Route ON	1.3 max.
Output Harmonics (2fc ; 3fc)	-40dBc ; -20dBc max. @ 100W
Pulse Width (internal limitation)	100ms @ 100W (up to CW @ 20W)
Duty Cycle (internal limitation)	20% @ 100W (up to 100% @ 20W)
Droop & Pulse Flatness	± 3% typical @ 100W for 100ms PW
Amplitude Stability vs. Temperature	± 0,2% / °C max.

Common Characteristics

7.3

Table 7.3. BLAH1000 E Common Characteristics

Constant Internal Protection	Supplies faults & Overtemperature Forward Power : peak & CW power pulse width duty cycle Reflected Power : peak & CW power
Front Panel Indicators	Amplifier Status Led Board
Front Panel Interfaces	1 x I/O 8 pins RJ45 connector
Front Panel controls	1 x SELH1000/H100 control signal
Front Panel connectors	3 x RF input, 2 x RF output, 1 x gating input
Rear Panel Interface	15 pins DIN 41612-H ERNI female connector (power supply connection)
Cooling System	Forced-air cooling (from front to rear)
Size	19" rack cabinet x 3U height x 580mm depth
Weight	26kg
Supply	Additional 220-230 VAC \pm 15% single phase switched power supply, Bruker part number W1304007. A front panel circuit breaker turns the AC Line ON/OFF A status led board, on the front panel, indicates the power supplies condition. Size : 19" rack cabinet x 2U height x 500mm depth Weight : 5kg

Service information and maintenance

8

Every intervention on the device must be carried out by a authorized and qualified person. Any failure due to a non-respect of the following instructions will not be attributable to BRUKER and will not be covered by the guarantee clauses.

Preventive maintenance of the RF module on BLA-type Amplifiers **8.1**

The RF module inside BLA's Amplifiers is equipped with a easily extractible PUSH and PULL FAN Assembly.

Fan's on assembly have a high reliability and manufacturer gives a expected live time of 70000 hours (8 years) at 25°C and 5 years at 60°C.

Replacement of the assemblies could be done in the field when a misfonction of fans is detected by lightning from the OVERHEAT Status Led.

To prevent such a misfonction, a preventive maintenance should be done every 4 years.

These assemblies can be ordered on the manufactory BBIO-FR by P/N:

- **W1346653** «PUSH FAN ASSEMBLY H1000»,
- **W1346654** «PULL FAN ASSEMBLY H1000».

Operation

8.1.1



Read below or see SIH0292.

1. Disconnect all cables from the front panel and the supply connector on the rear panel. Remove the amplifier from the NMR console and place it on a secure flat surface.
2. Unscrew and remove the coverage plate from the amplifier.
3. Disconnect the J1 and J2 from the Status Connections Board located on the RF module.

Figure 8.1. Status Connections Board

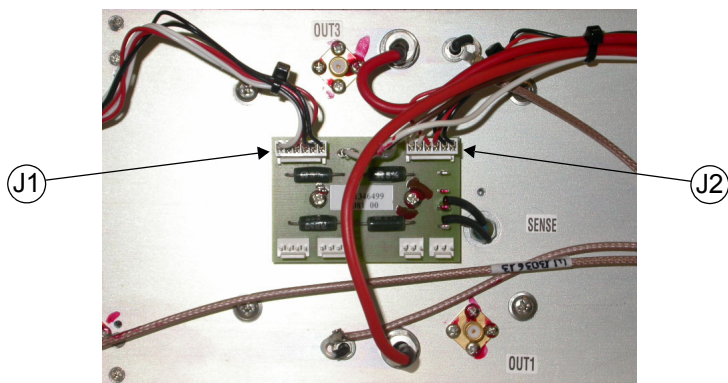

4. Unscrew the 2 screws on the top and the 2 nuts on the bottom of the Push and Pull fan assemblies.

Figure 8.2. Push and Pull Fan Assembly

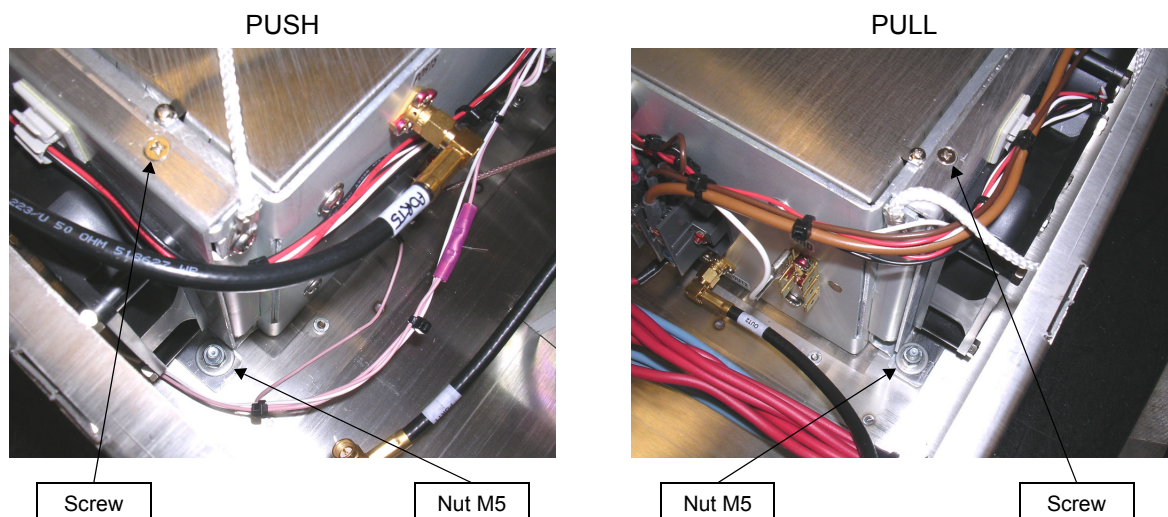

5. Remove the Push and the Pull fan assembly.
6. Place correctly the 2 new fan assemblies in the holes on the bottom of the RF module and screw the nuts at the bottom and the screws at the top.
7. Connect J1 and J2 connectors on the Status Connections Board.
8. Connect the supply cable from BLAH1000 E to the external power supply, turn on the amplifier. Note that the fans are turning and no OVERHEAT status led appears on front panel.
9. Put the coverage plate on the BLAH1000 E amplifier and screw it.
10. Put the amplifier in the NMR console, connect all cables on the front panel and the supply connector on the rear panel.

Figures

1	General information	5
2	Safety	7
Figure 2.1.	Identifying plate	7
Figure 2.2.	General hazard symbol	8
3	Installation	9
4	Operation	13
Figure 4.1.	BLAH1000 E Front Panel Design	15
Figure 4.2.	BLAH1000 E Front Panel View	15
Figure 4.3.	BLAH1000 E Rear View	16
5	Technical description	17
Figure 5.1.	BLAH1000 E System Block Diagram	18
Figure 5.2.	Embedded router Block Diagram	19
Figure 5.3.	Driver Block Diagram	20
6	Servicing the BLA	25
Figure 6.1.	Device Information	26
Figure 6.2.	Amplifier status (High Resolution and Solide)	27
Figure 6.3.	Amplifier limitations (High Resolution and Solide)	28
Figure 6.4.	Change limits (High Resolution and Solide)	29
Figure 6.5.	Routing information	30
Figure 6.6.	Self-test, software reset and report	31
Figure 6.7.	BIS content	32
Figure 6.8.	Firmware update	33
7	Specifications	35
8	Service information and maintenance	39
Figure 8.1.	Status Connections Board	40
Figure 8.2.	Push and Pull Fan Assembly	40

Figures

Tables

1	General information	5
2	Safety	7
3	Installation	9
4	Operation	13
Table 4.1.	Indicators assignment	13
Table 4.2.	Coaxial Connectors assignment	14
Table 4.3.	RJ45 Pin assignment	14
Table 4.4.	DIN 41612-ERNI Pin assignment	16
5	Technical description	17
6	Servicing the BLA	25
7	Specifications	35
Table 7.1.	BLAH1000 E Solid Output H1000 Specifications	35
Table 7.2.	BLAH1000 E High Resolution Output H100 Specifications	36
Table 7.3.	BLAH1000 E Common Characteristics	37
8	Service information and maintenance	39

