

BLAXH300/100

Amplifier 200-600MHz Operating & Service Manual

Version 001

BRUKER

The information in this manual may be altered without notice.

BRUKER accepts no responsibility for actions taken as a result of use of this manual. BRUKER accepts no liability for any mistakes contained in the manual, leading to coincidental damage, whether during installation or operation of the instrument. Unauthorised reproduction of manual contents, without written permission from the publishers, or translation into another language, either in full or in part, is forbidden.

This manual describes the units as they are at the time of printing. On request, the manufacturer shall supply circuit diagrams, lists of components, descriptions, calibrating instructions and any other information for use by qualified personnel of the user, in charge of repairing the parts of the unit which have been stated by the manufacturer to be "repairable". Such supply shall in no event constitute permission to modify or repair the units or approval of the same.

All rights reserved for the units, circuits, processes and appellations mentioned herein.

This unit is not designed for any type of use which is not specifically described in this manual. Such use may be hazardous.

This manual was written by

OTT Charles

© November 27, 2001: Bruker SA

Wissembourg, France

Manual P/N: Z31636
DWG-Nr: Drawing 1347.001

Contents

	Contents	3
	Index	5
1	General Information	7
1.1	Introduction	7
1.2	System Check	7
1.3	Initial Turn On Procedure	8
2	Safety	9
2.1	Labels	9
	Dangerous Area	9
	Name Plate	9
3	BLAXH300/100 Operation	11
3.1	Front Panel	11
	Indicators	11
	Connectors	12
	Interface Connector RS485	12
3.2	Rear Panel	13
4	Technical description	15
4.1	System Overview	15
4.2	Theory of Operation	17
	RF Path	17
	Control Board	18
	Supply Status Board	18
	Status Led Board	18
5	Specifications	19
5.1	General specifications	19
	Figures	23
	Tables	25

Index

A

AC input voltage 7

B

BLA DSP Control Board 18

N

Nominal input level 7

R

Revision Number 9

S

Serial Number 9

T

Type of the product 9

General Information

1

Introduction

1.1

The BLAXH300/100 (P/N : W1345062) is a linear broadband pulse power amplifier specifically designed for Nuclear Magnetic Resonance (NMR) applications for 4,7 to 14 Teslas Systems.

The class AB linear amplifier provides a 300W peak power output over the frequency range 6-365MHz on the X channel output and a 100W peak power output over the frequency range 180-600MHz on the H channel output.

The amplifier is realized by employing N-CHANNEL MOS BROADBAND RF POWER FETs of the latest generation. The unit can provide full power for any combination of pulse width / duty cycle up to 100ms / 25% for the H100 channel, and 100ms / 10% for the X300 channel. Its built-in protection circuitry will allow lower power pulses for longer pulse widths and duty cycles, maintaining a 30W X channel and a 25W H channel average power.

An electronic protection circuitry has been designed to protect against:

- Excessive power output level (overdrive)
- Excessive pulse repetition rate (over duty-cycle protection)
- Excessive pulse duration (over pulse-width)
- More than 50% reflected RF power (mismatch ≥ 6)
- Thermal overload (overheat)

The amplifier is powered by an internal switched power supply assembly that provides the 32VDC for the power amplifiers, in addition to all low level voltages for the system.

The supply is self protecting for overcurrent and overvoltage.

The entire unit is housed in a 19", 3U, 520mm rack cabinet.

System Check

1.2

Before applying power for the first time the following items should be checked:

- The AC input voltage from the Amplifier must be compatible with 176VAC to 264VAC range.
- External blanking (gating) pulses must be supplied to the amplifier in order for the unit to function. Ensure that these pulses are of proper level and logic polarity.
- The BLAXH300/100 amplifier has a nominal input level of +4dBm. Ensure that the system drivers are operating at these levels.

The following list describes how to turn on the BLAXH and what should be seen as this occurs.

Before starting this procedure, make sure that you have properly followed instructions in the "System Check" Section.

1. Connect the amplifier to the AC line and turn the circuit breaker on the front panel, to ON.
2. Observe the indicators on the front panel:
 - The +28V or +32V LEDs will illuminate
 - The +15V, -15V, and +5V LEDs will illuminate
3. System is now fully operational.

Labels

2.1

Labels are provided to alert operating and service personnel to conditions that may cause personal injury or damage to the equipment from misuse or abuse. Please read the labels and understand their meaning.

Dangerous Area

2.1.1

WARNING ! High Voltage.



Name Plate

2.1.2

Amplifiers BLAX serie can be identified by a name plate at the front panel of the unit which has information as follows :

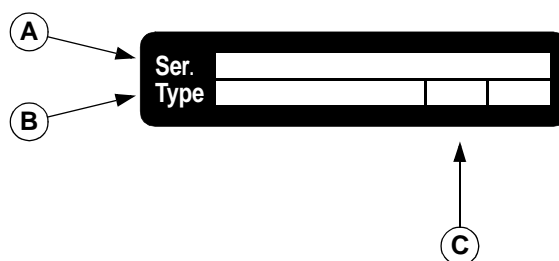

- **(A) Ser.**
This line contains an assembly number which identifies the Part and the Serial number of the product.
- **(B) Type**
This line contains the designation of the product.
- **(C) Revision**
This cell indicates the revision number which identifies the product configuration. The initial revision is 00.

BLAXH300/100 Operation

3

Front Panel

3.1

The BLAXH300/100 front panel is provided with 2 x 11 indicators for status monitoring, 6 connectors, and 2 interface connectors.

Indicators

3.1.1

Normal operation is indicated when following LED's are on :

Table 3.1. Indicators

+28V (+32V) ON	Indicates that the +28V or +32V supply is applied.
+15V ON	Indicates that the +15V supply is applied.
-15V ON	Indicates that the -15V supply is applied.
+5V ON	Indicates that the +5V supply is applied.
Overdrive	Indicates when the power limit has been reached.
Duty Cycle	Indicates when the duty cycle limit has been reached.
Pulse Width	Indicates when the pulse width limit has been reached.
Mismatch	Indicates when the max. reflected power limit has been reached.
RF Power FLT	Lights ON when one of the above limits has been reached.
Overheat	Indicates that the thermistor located on the RF Module heatsink has sensed excessive heatsink temperature. All gatings are removed from the amplifier until the unit cools. The function is self-resetting and no maintenance is needed.
X300 / H100	Lights on when RF Power is present.

Table 3.2. Connectors

X / H in	RF in SMA type connectors (female). Nominal +4dBm drive to the BLAXH Serie to deliver full power.
X / H out	RF OUT N type connectors (female).
BLNKX / BLNKH	Blanking signals BNC type connector (female). TTL logic, 5V = blanking ON, 0V = blanking OFF. When BLANKING signal is at TTL level high (+5V), no gating is applied to the amplifier stages, and no RF Power is possible. When BLANKING signal is at TTL level low (0V), the amplifier stages are gated and RF Power is possible.

The Control I/O interface connections are 15 pin, D shape sub-miniature type connectors mounted on the SBS BUS Controller.

SBS BUS = Serial Bruker Spectrospin Bus

The next table shows the pinout of the master and slave connectors.

Table 3.3. RS485 pinout assignment

Pin 1	Shield
Pin 2	Transmit data line +
Pin 3	Wake up line /WUP
Pin 4	Receive data line +
Pin 5	NC
Pin 6	GND
Pin 7	GND
Pin 8	GND
Pin 9	Transmit data line
Pin 10	NC
Pin 11	Receive data line
Pin 12	NC
Pin 13	VRS (+12V)
Pin 14	VRS (+12V)
Pin 15	VRS (+12V)

Figure 3.1. BLAXH300/100 Front Panel Design

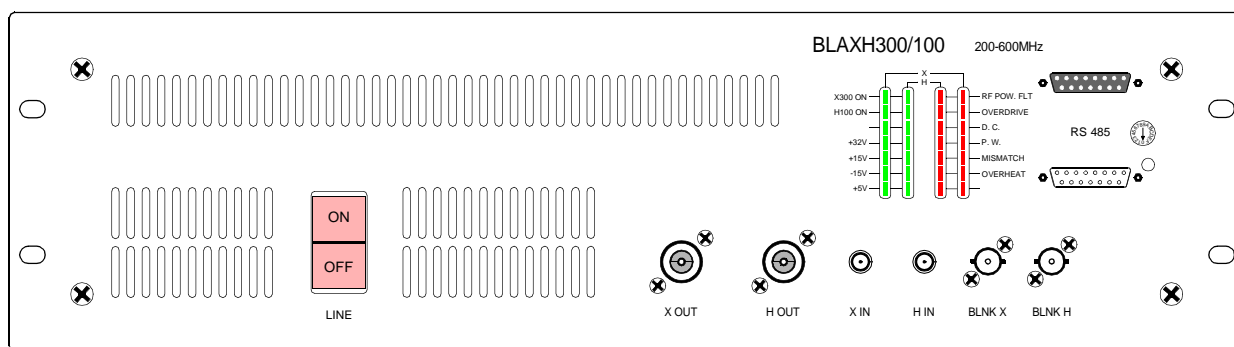

Figure 3.2. BLAXH300/100 Front Panel View



Rear Panel

3.2

The rear Panel of the BLAXH Serie Amplifiers is free of elements in exception of the three pole (2P + E) line filter socket.

Technical description

4

System Overview

4.1

The BLAXH300/100 amplifier provides a RF Output Power of 300W in the 6-365MHz frequency range, for the X channel, and a 100W RF Output Power in the 180 to 600MHz frequency range.

The RF section of the system consists of a linear module BLMXH300/100, mounted around a single, self-contained Push fan assembly, heatsink.

The linear module BLMXH300/100 includes two class AB power amplifiers. The amplifier for the H channel is located on the top side of the module, and the one for the X channel on the bottom side.

Each channel is connected to the front panel of the amplifier via a bi-directional coupler.

The entire system is tied together by a Digital Signal Processing control board, processing information from the amplifier, providing protection from excessive peak power, duty cycle and pulse width for average power, maximum reflected power and heatsink overtemperature.

Circuits such, Fan Status board, Supply Status board and LED's Status board, completes the amplifier assembly.

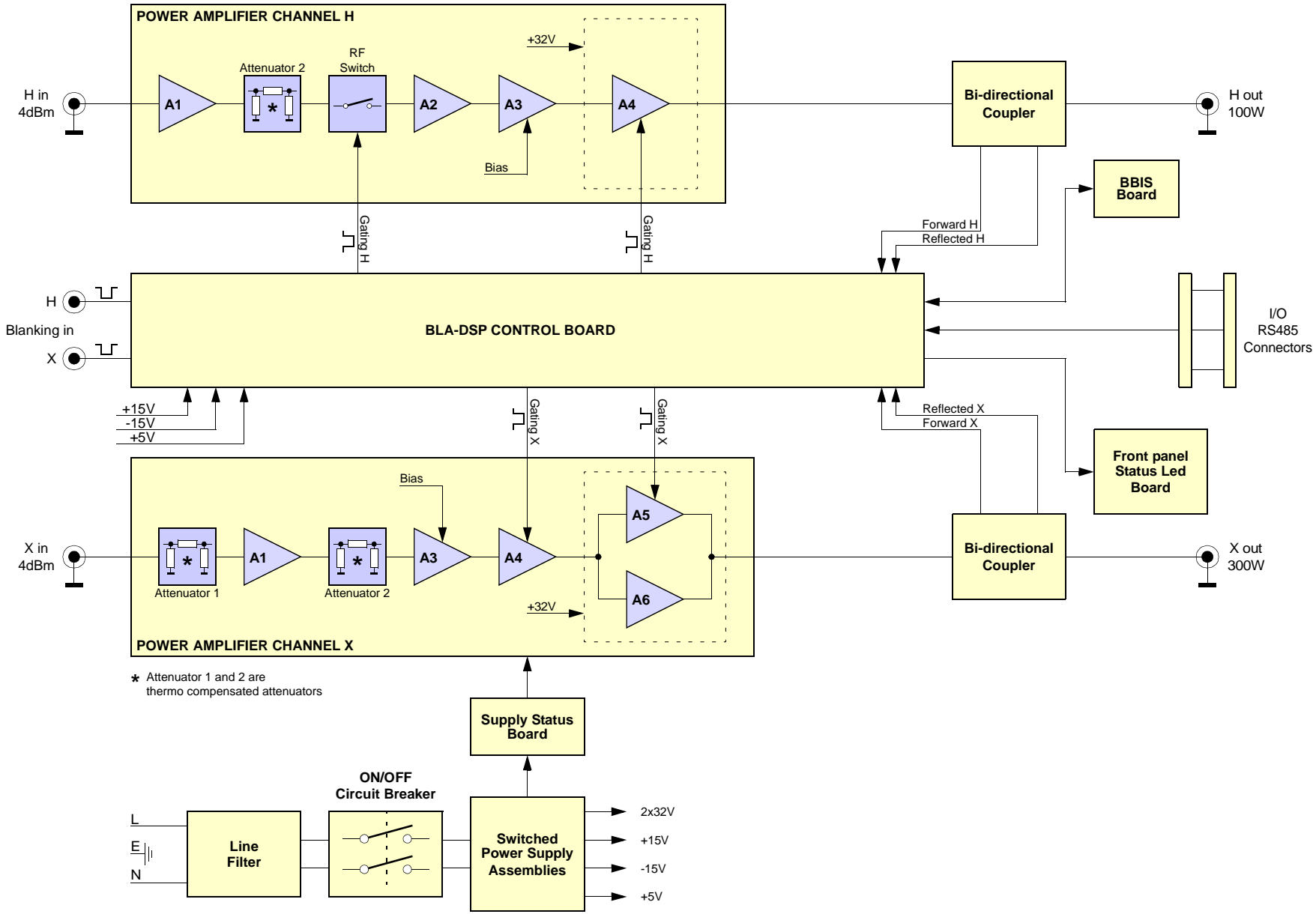

Figure 4.1. BLAXH300/100 System Block Diagram

Theory of Operation**4.2**

RF Path**4.2.1**

The BLAXH300/100 amplifier (P/N : W1345062) consists of two Class AB power amplifiers.

A nominal input power level of +4dBm produce a nominal output power of 300W peak for 10% duty cycle at 100ms pulse width maximum on the X channel output, and a 100W peak for 25% duty cycle at 100ms pulse width maximum on the H channel.

The unit is also capable of longer pulses for lower average power, up to CW at 30W.

RF Power Amplifier Channel X300

In the first section of this power amplifier, the input RF signal is fed through an optional thermo compensated attenuator to a hybrid amplifier followed by a second thermo compensated attenuator and two class A drivers to built a nominal 40dB to 44dB gain block.

In this section, only the second class A driver requires a control board conditioned gating signal to bias gate voltage on the gates of the FETs.

The second section of the PA includes two FET transistors.

The circuitry around the transistors consists of complementary input and output transformers and baluns and operates the devices in push-pull.

This section requires a control board conditioned gating signal in order to control the bias gate voltage on the gates of the FETs.

The input-output gain of this section is at nominal 13dB.

The entire RF power amplifier has a nominal 53dB of gain, and operates off +32VDC.

RF Power Amplifier Channel H100

In the first section of this power amplifier, the input RF signal is fed through a hybrid amplifier followed by a thermo compensated attenuator, a RF switch and two class A drivers to built a nominal 40dB gain block.

In this section, only the RF switch requires a control board conditioned gating signal.

The second section of the PA includes one FET transistor.

The circuitry around the transistor consists of complementary input and output transformers and baluns and operates the devices in push-pull.

This section requires a control board conditioned gating signal in order to control the bias gate voltage on the gates of the FET.

The input-output gain of this section is at nominal 10dB.

The entire RF power amplifier has a nominal 49dB of gain, and operates off +32VDC.

RF Coupler

The bi-directional couplers on the front panel provides an approximate 1V peak DC signal for full output power from the envelope.

The bi-directional couplers also provides peak DC signal for reflected power.

Both signals, forward and reflected, are analyzed by the control board for monitoring and protection setting.

Control Board

4.2.2

The BLA Control Board consists of circuitry to monitor the output characteristics of the amplifiers as determined from the DC peak detection's from the bi-directional couplers, and to condition the input blanking (gating) signals and deliver them to the above mentioned RF Paths.

The monitoring circuitry also serves to process the information from the detection's and protect the amplifier from overstress in peak power, average power versus duty cycle and pulse width, so as reflected power.

The control board also monitors the RF Path heatsink temperature to protect against thermal overstress.

Information from supplies and fan status board also being analyzed by the control board.

If one of the above overstresses, or faults on power supplies or fans, appears, the gating signals are disabled, and the status led board on the front panel displays the fault.

Supply Status Board

4.2.3

This board gives the information of the status of the power supplies.

A defect on one or more of the supplies is read by the control board, and in case of, the gating signals are disabled while the defect is visualized on the front panel led display.

Status Led Board

4.2.4

The Status Led Board, on the front panel of the amplifier, displays overstress functions, supplies status, and so on, as described in section **"Indicators" on page 11.**

Specifications

5

General specifications

5.1

Table 5.1. BLAXH300/100 general specifications channel X300

Frequency range	6 to 365MHz
Linear Gain	53dB typical
Gain Flatness	± 1dB
Peak Pulse Power	300W min. full range
CW Power (limited)	30W max.
Linear Output Power	300W @ 1dB compression typical
Linearity	± 1dB to 300W
Amplifier biasing	Class AB Operation
Input / output Impedance	50Ω
RF Rise Time	< 100ns, 10 - 90% peak power
RF Fall Time	< 50ns, 90 - 10% peak power
Blanking Delay Time	< 1μs typical
Noise Figure	7dB max.
Output Noise Power (unblanked) (blanked)	< -114dBm / Hz Thermal noise
Pulse Width (limited)	100ms @ 300W (up CW @ 30W)
Duty Cycle (limited)	10% @ 300W (up to 100% @ 30W)
Amplitude Droop	< 6% @ 300W for 20ms Pulse width < 3% @ 300W for 1ms Pulse width
Amplitude stability versus temperature	± 0,1% / °C

Specifications

Table 5.2. BLAXH300/100 general specifications channel H100

Frequency range	180 to 600MHz
Linear Gain	49dB typical
Gain Flatness	± 1dB
Peak Pulse Power	100W min. 220 to 600MHz (80W 180 to 220MHz)
CW Power (limited)	25W max.
Linear Output Power	80W @ 1dB compression typical
Linearity	± 1dB to 80W
Amplifier biasing	Class AB Operation
Input / output Impedance	50Ω
RF Rise Time	< 100ns, 10 - 90% peak power
RF Fall Time	< 50ns, 90 - 10% peak power
Blanking Delay Time	< 1μs typical
Noise Figure	6dB max.
Output Noise Power (unblanked) (blanked)	< -119dBm / Hz, 20dB over thermal
Pulse Width (limited)	100ms @ 100W (up CW @ 25W)
Duty Cycle (limited)	25% @ 100W (up to 100% @ 25W)
Amplitude Droop	< 4% @ 100W for 20ms pulse width
Amplitude stability versus temperature	± 0,1 % / °C

Table 5.3. BLAXH300/100 Common Specifications

Constant Internal Protection	Supplies faults & Over temperature Forward Power : peak & CW power pulse width duty cycle Reflected Power : peak & CW power
Front Panel Indicators	Amplifier Status Led Board
Front Panel Interfaces	2 x I/O 15-pin subminiature type D connectors
Front Panel controls	AC Line ON / OFF
Front Panel connectors	2 x RF input, 2 x RF output, 2 x gating input
Rear Panel Interface	AC Line in socket
Cooling System	Forced air cooling (from front to rear)
Size	7" H x 19" rack cabinet x 20,4" D (17,8 x 48,3 x 52cm)
Weight	29 kg
Power requirements	180 - 276VAC, single phase 50 - 60Hz

Figures

1	General Information	7
2	Safety	9
3	BLAXH300/100 Operation	11
	Figure 3.1. BLAXH300/100 Front Panel Design	13
	Figure 3.2. BLAXH300/100 Front Panel View	13
4	Technical description	15
	Figure 4.1. BLAXH300/100 System Block Diagram	16
5	Specifications	19

Tables

1	General Information	7
2	Safety	9
3	BLAXH300/100 Operation	11
Table 3.1.	Indicators	11
Table 3.2.	Connectors	12
Table 3.3.	RS485 pinout assignment	12
4	Technical description	15
5	Specifications	19
Table 5.1.	BLAXH300/100 general specifications channel X300	19
Table 5.2.	BLAXH300/100 general specifications channel H100	20
Table 5.3.	BLAXH300/100 Common Specifications	21

