



Bruker Automated Control Systems

B-ACS 60/120 Installation & User Manual

Version 003



The information in this manual may be altered without notice.

BRUKER BIOSPIN accepts no responsibility for actions taken as a result of use of this manual. BRUKER BIOSPIN accepts no liability for any mistakes contained in the manual, leading to coincidental damage, whether during installation or operation of the instrument. Unauthorized reproduction of manual contents, without written permission from the publishers, or translation into another language, either in full or in part, is forbidden.

This manual was written by

Stanley J. Niles and Volker Reiss

© December 7, 2006: Bruker Biospin GmbH

Rheinstetten, Germany

P/N: Z31597
DWG-Nr.: 1309003

DECLARATION OF CONFORMITY

H1080	B-ACS 60 Sample Changer
H91080	B-ACS 60/300 Sample Changer
H131080	B-ACS 60/300 Sample Changer SAG Anti-vibration
H9874	B-ACS 60 Sample Changer 400US+
H141080	B-ACS 60/400 Sample Changer SAG Anti-vibration
H9875	B-ACS 60 Sample Changer 500US+
H41080	B-ACS 60/500 Sample Changer SAG
H31080	B-ACS 60/500 Sample Changer Magnex
H9876	B-ACS 60 Sample Changer 600US+
H11080	B-ACS 60/600 Sample Changer OXF
H21080	B-ACS 60/600 Sample Changer Magnex
H5895	B-ACS 60/600 Sample Changer SAG
H51080	B-ACS 60/700 Sample Changer SAG
H101080	B-ACS 60/750-800SB Sample Changer BAM
H111080	B-ACS 60/800US2 Sample Changer BAM
H151080	B-ACS 60/800 Sample Changer Magnex
H61080	B-ACS 60 Sample Changer SAG D330
H71080	B-ACS 60 Sample Changer SAG D340
H81080	B-ACS 60 Sample Changer SAG D350
H121080	B-ACS 60/D360 Sample Changer WB
H14163	B-ACS 60 Sample Changer 750US+

conform to the main requirements set by the commission for the Harmonization of Regulations of the EU Member States with regards to electromagnetic compatibility regulations (EMI: 89/336/ECC), safety regulations (Low Voltage Electrical Equipment: 72/23/ECC), and machinery directives (89/392/EEC).

For the assessment the following norms were applied:

EMI: EN 61326:97 + A1:98 + A2:01 + A3:03 Class A;
EN 61000-3-2:2000; EN61000-3-3:1995 + A1:2001
Safety: EN 61 010 - 1

Machinery Directives: EN 292 - 1 & 2

Test report: UNI KA 9522
Documentation: Z31285Docu Standard: Sample Changer

Manufacturer's Name: Bruker BioSpin GmbH
Manufacturer's Address: 76287 Rheinstetten, Silberstreifen,
Germany

Declaration approved by:

Dr. Tonio Gianotti

Head of Development

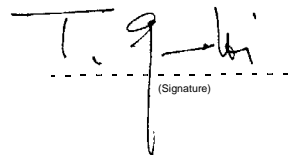

(Signature)

16.06.2005

Rheinstetten

DECLARATION OF CONFORMITY

The under mentioned products

H800	B-ACS 120 Sample Changer
H13800	B-ACS 120/300 Sample Changer
H15800	B-ACS 120/300 Sample Changer SAG Anti-vibration
H9877	B-ACS 120 Sample Changer 400US+
H16800	B-ACS 120/400 Sample Changer SAG Anti-vibration
H9878	B-ACS 120 Sample Changer 500US+
H6800	B-ACS 120/500 Sample Changer SAG
H3800	B-ACS 120/500 Sample Changer Magnex
H9879	B-ACS 120 Sample Changer 600US+
H1800	B-ACS 120/600 Sample Changer
H8800	B-ACS 120/600 Sample Changer Magnex
H4800	B-ACS 120/600 Sample Changer SAG
H9800	B-ACS 120/700 Sample Changer SAG
H10800	B-ACS 120 Sample Changer SAG D330
H11800	B-ACS 120 Sample Changer SAG D340
H12800	B-ACS 120 Sample Changer SAG D350
H14800	B-ACS 120/D360 Sample Changer WB
H14164	B-ACS 120 Sample Changer 750US+

conform to the main requirements set by the commission for the Harmonization of Regulations of the EU Member States with regards to electromagnetic compatibility regulations (EMI: 89/336/ECC), safety regulations (Low Voltage Electrical Equipment: 72/23/ECC), and machinery directives (89/392/EEC).

For the assessment the following norms were applied:

EMI: EN 61326:97 + A1:98 + A2:01 + A3:03 Class A;
EN 61000-3-2:2000; EN61000-3-3:1995 + A1:2001
Safety: EN 61 010 - 1

Machinery Directives: EN 292 - 1 & 2

Test report: UNI KA 9522
Documentation: Z31285Docu Standard: Sample Changer

Manufacturer's Name: Bruker BioSpin GmbH
Manufacturer's Address: 76287 Rheinstetten, Silberstreifen,
Germany

Declaration approved by:

Dr. Tonio Gianotti

Head of Development

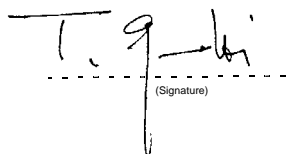

(Signature)

Rheinstetten

16.06.2005

Contents

	Contents	5
1	Introduction	11
1.1	Introduction	11
1.2	Site Considerations	11
1.3	Disclaimer	11
1.4	Warnings and Notes	12
1.5	Contact for Additional Technical Assistance	12
2	Safety Considerations	13
2.1	Before Mounting the Automatic Sample Changer	13
2.2	While Mounting the Column	13
2.3	During Operation	13
2.4	At the End of Operation	14
2.5	Potentially Hazardous Areas	14
2.6	Extreme Temperatures	14
3	Mounting Instructions	15
3.1	Caution	15
3.2	Preparing the Magnet for Installation	16
3.3	Connecting the Light Barrier Assembly	16
3.4	Mounting the Cabinet	18
3.5	Preparing the Column for Assembly	19
3.6	Assembling the Column	19
3.7	Mounting the Column Assembly to the Magnet	20
	For Magnets without N2 Towers:	20
	For Magnets with N2 Towers:	21
3.8	Mounting the Pneumatic Arm Assembly	22
3.9	Securing the Bottom of the Column Assembly	23
3.10	Connecting the Hoses and Cables	25
	Remote Hose Connections	26
	Connecting the Mains and RS232 Cable	28
3.11	Description of Input and Output Locations	29
4	Settings and Adjustments	31
4.1	General	31
4.2	Mechanical Settings	31
	Pneumatic Arm Adjustment	33
	Cabinet and Magazine Belt Adjustment	35
	Vertical Cylinder Adjustment	36
4.3	Fine Adjustment Procedures	37
	Settings at the Magnet	38

	Prepare the Sample Changer as Follows:	38
	Settings at the Magazine	39
	Adjustment of the Tension of the Magazine Belt	39
4.4	Pneumatic Cylinder Settings	40
4.5	Final Setup	41
5	<i>Operating Instructions</i>	43
5.1	General	43
	Front Panel Controls	43
	Connections	44
5.2	Starting the B-ACS 60 or 120	44
5.3	Fitting Samples into the Sample Magazine	44
5.4	Individual Commands via the RS-232	44
	Test for Sample in Magnet (security test)	45
5.5	Manual Motion (Control) of the Magazine Belt	45
5.6	The Occurrence of a Failure	45
6	<i>Software Commands</i>	47
6.1	General	47
6.2	Communication Path from the Host Computer	47
	RS Test	47
	Unitool	47
6.3	Communication Path from a Windows Notebook Computer	47
	Hyperterminal	48
	Unitool	48
	Reconnecting the Serial Link Cable	48
6.4	Switching to Diagnostic Mode	48
6.5	Switching to Operation Mode	49
6.6	B-ACS 60/120 Command Implementation	49
6.7	List of Commands	50
	Normal Operation Mode	50
	Error Mode	67
6.8	Additional Commands Enabled in Diagnostic Mode	69
7	<i>List of Errors</i>	77
7.1	Introduction	77
	Error Message Structure	77
7.2	General Checks before Detailed Troubleshooting	77
7.3	Simple Errors with Error Number and Message	78
	Error 01: Insufficient Air Pressure	78
	Error 02: Downwards Motion Failed and Error 03: Upwards Motion Failed	78
	Error 04: Outwards Motion Failed and Error 05: Inwards Motion Failed	79
	Error 06: Pincer Opening Failed and Error 07: Pincer Closing Failed	79
	Error 08: Carrousel Motion Failed	80
	Error 09: Carrousel Position Undefined	80
	Error 10: Sample Holder Not Empty	81
	Error 11: Sample Detect At Magnet Failed	82

	Error 12: Sample Detect At Carrousel Failed	83
	Error 13: Sample Detect At Magnet Failed	84
	Error 14: Sample Grasping Failed	85
	Error 15: Shim System Not Empty	86
	Error 16: Code Wheel Detection Failed! Code: xxx	87
	Error 21: Codewheel Misadjusted For Position No: xxx	88
	Error 22: No Free Magazine Position	88
	Error 23: Sample Missing	89
	Error 25: Failure Of Spinning Device	89
	Error 26: Arm Positioning Failed	90
	Error 50: Barcode Reader Not Present	91
	Error 51: Invalid Command	92
	Error 52: Invalid Parameter	93
	Error 54: Horizontal Optic Not Present	93
	Error 55: Autoprep Hardware Not Present	93
	Error 57: xx Command Is Not Available In Diagnostics!	94
	Error 59: Busy	94
	Errors Greater than 80	95
	Error 80.x	95
	Error 80.1: Sensor Error: Horizontal Cylinder. Magazine & Shim!	95
	Error 80.2: Sensor Error: Horizontal Cylinder. Magazine & Not A2 Inner!	95
	Error 80.3: Sensor Error: Horizontal Cylinder. Magazine & A2 Outer!	95
	Error 80.4: Sensor Error: Horizontal Cylinder. Shim & A2 Inner!	96
	Error 80.5: Sensor Error: Horizontal Cylinder. Shim & A2 Outer!	96
	Error 81: Sensor Error: Vertical Cylinder. Up & Down!	96
	Error 82.x:	97
	Error 82.1: Sensor Error: Sample At Magnet. Lish & Sample Down!	97
	Error 82.2: Sensor Error: Sample At Magnet. Lish Is Closed!	97
	Error 82.3: Sensor Error: Sample At Magnet. Sample Is Down!	98
	Error 83: Sensor Error: Sample At Magazine!	99
7.4	Complex Errors without Error Message	100
8	Special Tools	103
8.1	Special Tools for B-ACS	103
9	Operator Maintenance	105
9.1	Greasing the Horizontal Arm	105
9.2	Greasing the Vertical Cylinder	105
9.3	Arm Adjustment	105

9.4	Cabinet Adjustment	105
9.5	Vertical Cylinder	105
9.6	Magazine Belt Tension Adjustment	106
9.7	Pneumatic Cylinder Setting	106
9.8	Cleaning the Inside of the Vertical Cylinder	106
9.9	Cleaning the Magazine Light Barrier	106
10	Technical Data	107
10.1	Equipment Identification	107
10.2	Power Supply Requirements	108
10.3	Fuse Protection	108
10.4	Air Requirements	108
11	Circuit Diagrams	109
11.1	List of B-ACS Circuit Diagrams	109
11.2	Circuit Boards	112
	CPU Board H25	112
11.3	B-ACS Interface Board Diagram	114
	LC-Display Board	114
	Mounting the Light Barrier Cabinet on the Magazine	114
	Mounting Instructions	114
	Adjusting the Light Barrier Cabinet and Optics	116
	Position Switch	116
	Adjusting the M60 Light Barrier Optic	117
	Adjusting the M120 Optic	118
	Mechanical Adjustment Procedures	119
	Adjustment Instructions for the B-ACS Magazine Light Bar- rier 119	
	Default Adjustment for New Devices	119
11.4	B-ACS RS232C Serial Link	121
	System Parameters	121
	Power Supply Box	124
12	Barcode Reader Option	125
12.1	General	125
12.2	The Standard Vertical Barcode Reader	125
	Mounting Instructions	126
	Preparing the Sample Changer and Barcode Reader Unit	126
	Mounting the barcode Reader Unit on the Cabinet	126
	Installing the Barcode Detection Board	127
	Putting the Barcode Reader Into Operation	128
	Adjusting the Threshold of the Reflex Sensors	128
12.3	Rotating Collar Barcode Reader (old version)	129
	Mounting Instructions	130
	Installing the Barcode Detection Board	130
	Preparing the Sample Changer and Barcode Reader Unit	130
	Mounting the Barcode Reader Unit on the Cabinet	
	131

	Mounting the Barcode Pressure Reducer	131
	Putting the Barcode Reader Into Operation	132
	Adjusting the Air Pressure of the Barcode Reader	132
	Centering the Samples in the Barcode Reader	133
	Adjusting the Scanner Optics on the Barcode Reader	133
	Final Step	134
	Test points on the Adapter Boards	134
	M120	134
	M60	134
	Communication Protocols for the Thermo-printer V3.1 ..	134
	DIP Switch Setting Overview for the F&O Label Printer	135
	Label Handling	136
	Schematic Diagrams	137
13	Sample Heater Option	139
13.1	General	139
13.2	Prerequisites	140
13.3	Warning: Extreme Temperatures	141
13.4	Installation	142
13.5	Operating instructions	142
13.6	Start-up	143
	Test conditions	143
13.7	B-ACS Heater Power Supply	144
	The B-ACS Heater Power Supply with Two PK100	145
	Adjusting the PK100 In Parallel	145
	Adjustment Of The Over-voltage Protection (OVP)	145
	Adjustment Of The Output Voltage (Vout)	145
	Connectors on the PK100 Supply Module	146
	The B-ACS Heater Power Supply with PK240	147
	Adjusting the PK240	147
	Adjustment Of The Over Voltage Protection (OVP)	147
	Adjustment Of The Output Voltage (Vout)	147
	Connector on PK240 Supply Module	148
	Pin Assignment Rear Panel	148
	Electrical characteristics	149
A	500 MHz and 600 MHz SAG Magnets	151
A.1	Introduction	151
A.2	Mounting Instructions	151
	Preparation	151
	Mounting the Base Plate	152
	Mounting the Column Assembly	154
	Final Adjustments	155
B	Sequence for Mounting & Adjusting B-ACS	157
B.1	Sequence for Mounting & Adjusting B-ACS	157

Contents

Figures 161

Tables 165

Index 167

Introduction

1

Introduction

1.1

The BRUKER Automatic Sample Changer, used in conjunction with BRUKER XWINNMR software, provides dialog-guided facilities which allow the user to easily and effectively perform automatic (continuous) experiments. Features include a 60 or 120 sample capacity, random accessing of samples, positive sample identification with the optional barcode reader, and temperature control of individual samples with the optional sample heater unit.

The standard NMR software includes the comprehensive automation package required for the Automatic Sample Changer. It features automatic instrument optimization, phasing, integration and plotting. Specialized routines assist data interpretation. Easy set-up procedures are accomplished via dialog software at three user-interface levels.

Site Considerations

1.2

The Automatic Sample Changer should be setup in a standard laboratory environment. Maximum room temperature should not exceed the range from 10-30°C. For more information refer to the Avance spectrometer manual on site planning available from Bruker.

Disclaimer

1.3

The B-ACS sample changer is intended for keeping NMR samples in its carousel magazine, inserting them into the NMR spectroscopy magnet and ejecting them after measurement back into the magazine. Use of the unit for any purpose other than that for which it is intended is taken only at the users own risk and invalidates any and all manufacturer warranties.

Service or maintenance work on the unit must be carried out by qualified personnel.

Only those persons schooled in the operation of the B-ACS should operate the unit.

Read this manual before operating the unit. Pay particular attention to any safety related information.

There are two types of information notices used in this manual. These notices highlight important information or warn the user of a potentially dangerous situation. The following notices will have the same level of importance throughout this manual.



Note: Indicates important information or helpful hints



WARNING: Indicates the possibility of severe personal injury, loss of life or equipment damage if the instructions are not followed.

For further technical assistance on the B-ACS systems, please do not hesitate to contact your nearest BRUKER dealer or contact us directly at:

BRUKER BioSpin GMBH
am Silberstreifen
D-76287 Rheinstetten
Germany

Phone: + 49 721 5161 0
FAX: + 49 721 5171 01
E-mail: nmr-software-support@bruker.de
Internet: www.bruker-biospin.de

Safety Considerations

2

Before Mounting the Automatic Sample Changer

2.1

Make sure the magnet is firmly secured to its base in order to prevent the instrumentation from tipping over.

While Mounting the Column

2.2

When assembling the column, do not tighten the top fastening ring too hard, as this may cause damage to the column surfaces.

When fixing the column to the magnet, mount the bottom arms so that they do not obstruct access when adjusting or changing probes.

When handling tools, screws, or any metallic parts beware of the strong magnetic field.

During Operation

2.3

- Excessive tension of the magazine belt will damage the belt and wheel bearings. (Refer to "**Cabinet and Magazine Belt Adjustment**" on page 35 for adjustment of the tension of the magazine belt).
- Beware of the strong magnetic field while working around the magnet. Keep all metal objects, such as tools, screws, or any metallic parts away from the magnet. Remove any mechanical watches or metallic objects while working around the magnet.
- When the Automatic Sample Changer is running, avoid putting hands or objects in the path of the arm, magazine belt or pincher, as this may cause personal injury or damage to the equipment.
- Be aware that the B-ACS horizontal & vertical cylinder, pincher or magazine may start a movement unexpectedly.
- Glass tubes may contain hazardous substances. If a glass tube breaks, refer to the corresponding precautions and cleaning/disinfection instructions. Only trained personnel should be allowed to operate B-ACS. Staff training is the responsibility of the owner of the system, Bruker will not be responsible for damage resulting from improper training.
- The use of nitrogen as an operating resource instead of compressed air may lead to an oxygen deficiency in the laboratory, e.g. through a technical defect (burst in pneumatic hose). ***It is highly recommended that oxygen warning device(s) be installed in the laboratory.***

Safety Considerations

At the End of Operation

2.4

Turning off the B-ACS may cause a short motion of the horizontal cylinder due to the opening of all the valves.

Potentially Hazardous Areas

2.5



The symbol shown on the left indicates a **potentially hazardous area** (ISO 3864; DIN 40008).

The symbol is placed on the following areas of the Automatic Sample Changer:

1. On the upper left half of the front side (side that is away from the magnet) of the vertical cylinder. **Warning:** When the sample changer is in operation keep hands and other objects away from the pinchers on the end of the vertical cylinder.
2. On the front side of the upper column assembly. **Warning:** Keep hands and other objects away from the path of the pneumatic arm and magazine belt (***"Arrangement of Pneumatic Arm Assembly" on page 22***) during operation of the sample changer.

If one of these symbols is missing, please contact Bruker for a replacement!

Extreme Temperatures

2.6

The optional sample warmer (see ***"Sample Heater Option"***) located on the magazine belt reaches extreme temperatures: **Warning:** Do not insert your fingers into the sample warmer. When the sample warmer is operating it can reach temperatures exceeding 70°C.

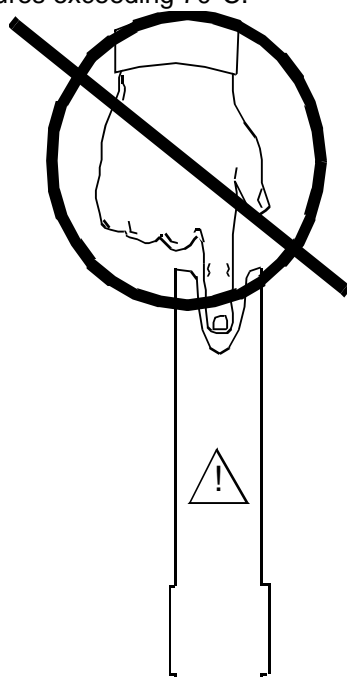

Warning! Extreme Temperature!
Do not put your finger into the sample warmer!

Figure 2.1. Extreme Temperature Warning

Mounting Instructions

3

Caution

3.1

Before mounting the Automatic Sample Changer, it is important to make sure that the magnet is firmly anchored to its base in order to prevent the instrumentation from tipping over. When doing so, carefully align the legs and lifting lugs used to secure the Sample Changer. The Sample Changer is held to the magnet by four adjustable arm assemblies (two for magnets with active dampers or TMC legs). The arm assemblies should be aligned with the magnet as shown in the figure below:

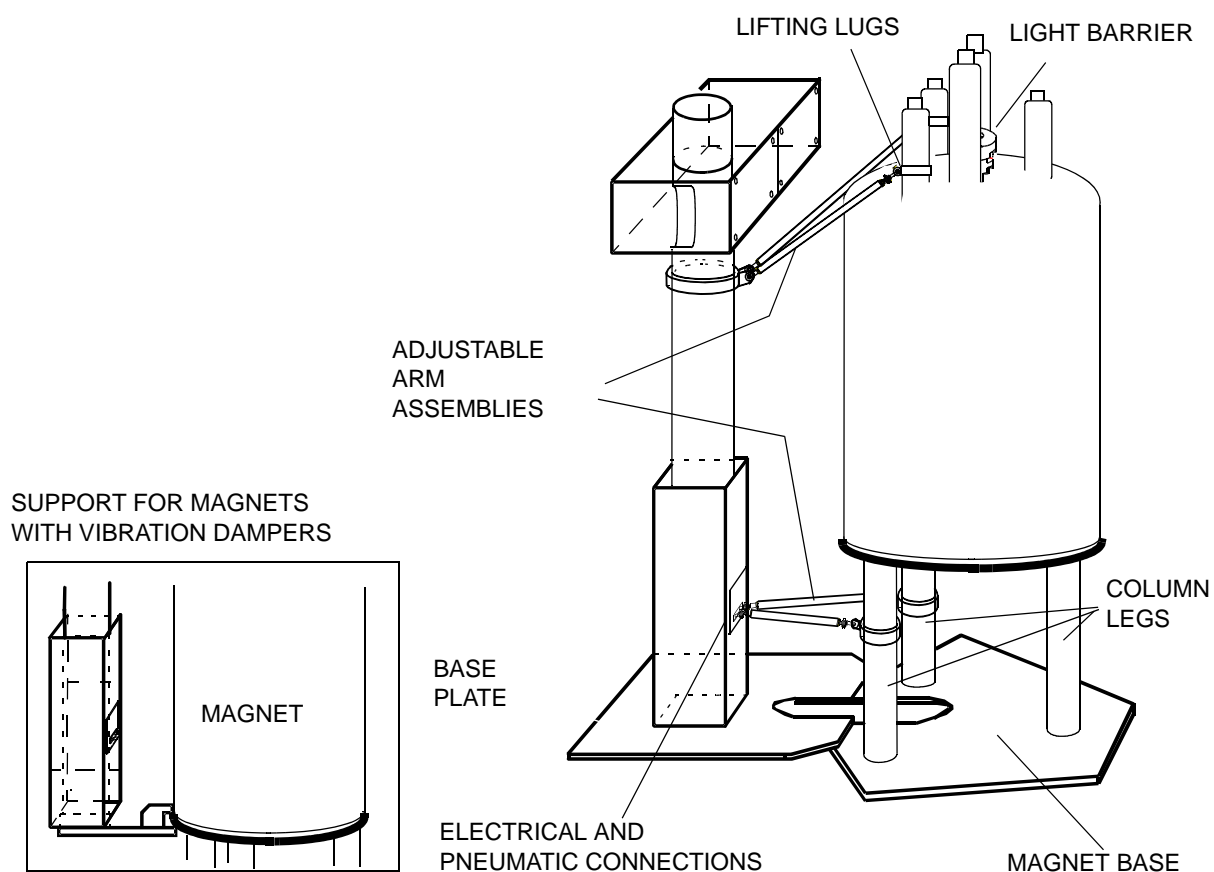

Figure 3.1. Location of Adjustable Arm Assemblies

Mounting Instructions

The following figure shows other anchoring methods for B-ACS that may be used depending on the magnet type:

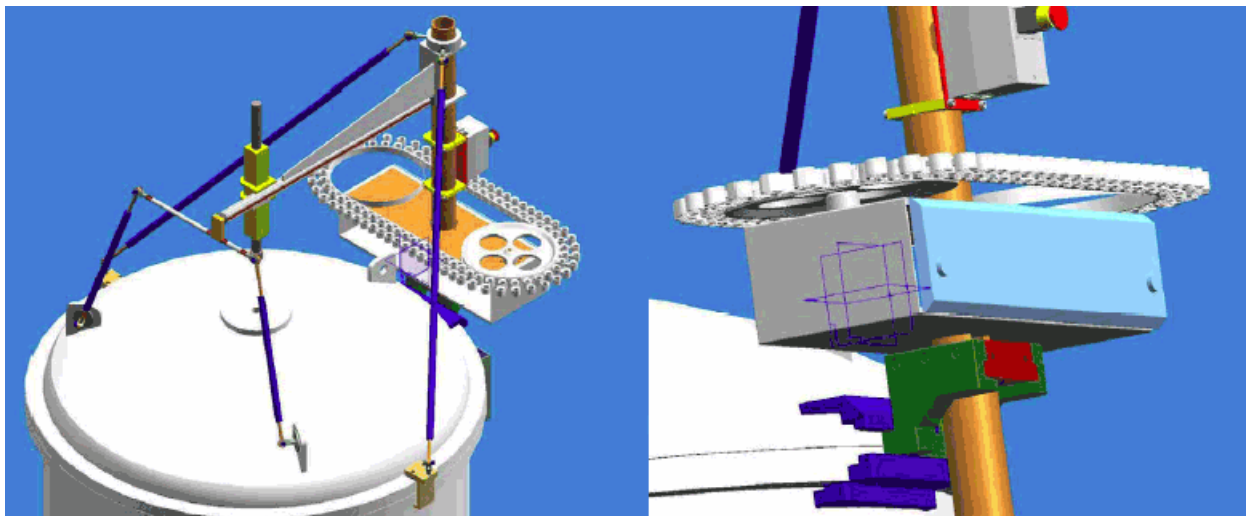

Figure 3.2. Other Anchoring Methods for B-ACS

Preparing the Magnet for Installation

3.2

The bottom arms of the sample changer are designed to fit 65 mm ϕ legs, they are adjustable in length to allow for compensation of construction tolerance.

If for some reason it is not possible to move, fix, or align the legs of the magnet, new bottom arms at the proper length can be delivered as an option. Please inform a Bruker representative about the misalignment angle or the necessary arm length, new arms will be shipped as soon as possible.

Connecting the Light Barrier Assembly

3.3



Note: Magnets with the BOSS 1 and BOSS 2 Shim Systems do not require this step, they are delivered with the light barrier cylinder already installed.



Figure 3.3. Magnet with BOSS Shim System Already Mounted

Mount the light barrier cylinder by placing it onto the top of the shim system and fastening the three side screws (see [Figure 3.4.](#)). To correctly place the light cylinder barrier, push the cylinder down firmly while turning the cylinder into position (the fitting may be tight). This will guarantee minimal loss of sample lift air between the shim system and the cylinder.

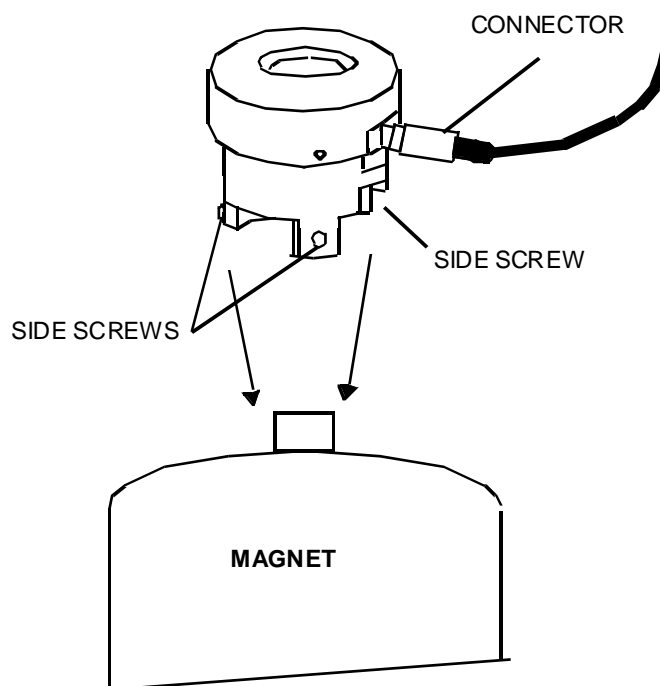
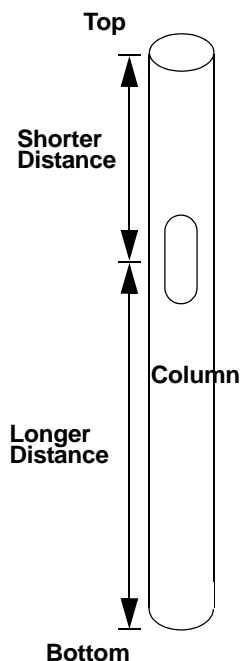

Figure 3.4. Light Barrier for the Shim System

Mounting the Cabinet

3.4



The sample changer cabinet is fitted with a display unit on the front side. The rear side is the side that faces the magnet. Remove the rear side panel from the rear of the cabinet. Open the front panel of the cabinet by loosening the screws. The cabinet is fixed to the column by a cylindrical collar. Loosen the screws from the top cylindrical collar (see [Figure 3.5](#), # 1) before mounting the unit onto the column.

Place the cabinet on its side on a soft surface such as a blanket or carpet. This position will make it easier to slide the column through the cabinet.

Note: The top end of the round column piece is the end with the shortest distance from the side opening to the end of the column piece (see the drawing to the left).

Insert the top end of the round column piece from the bottom side of the cabinet into the cabinet cylindrical collar, pushing it through until the side opening on the column disappears inside the cabinet (see [Figure 3.5](#), # 2). Mount the cabinet resting ring between the side opening and the cylindrical collar. Tighten both the resting ring and the collar.

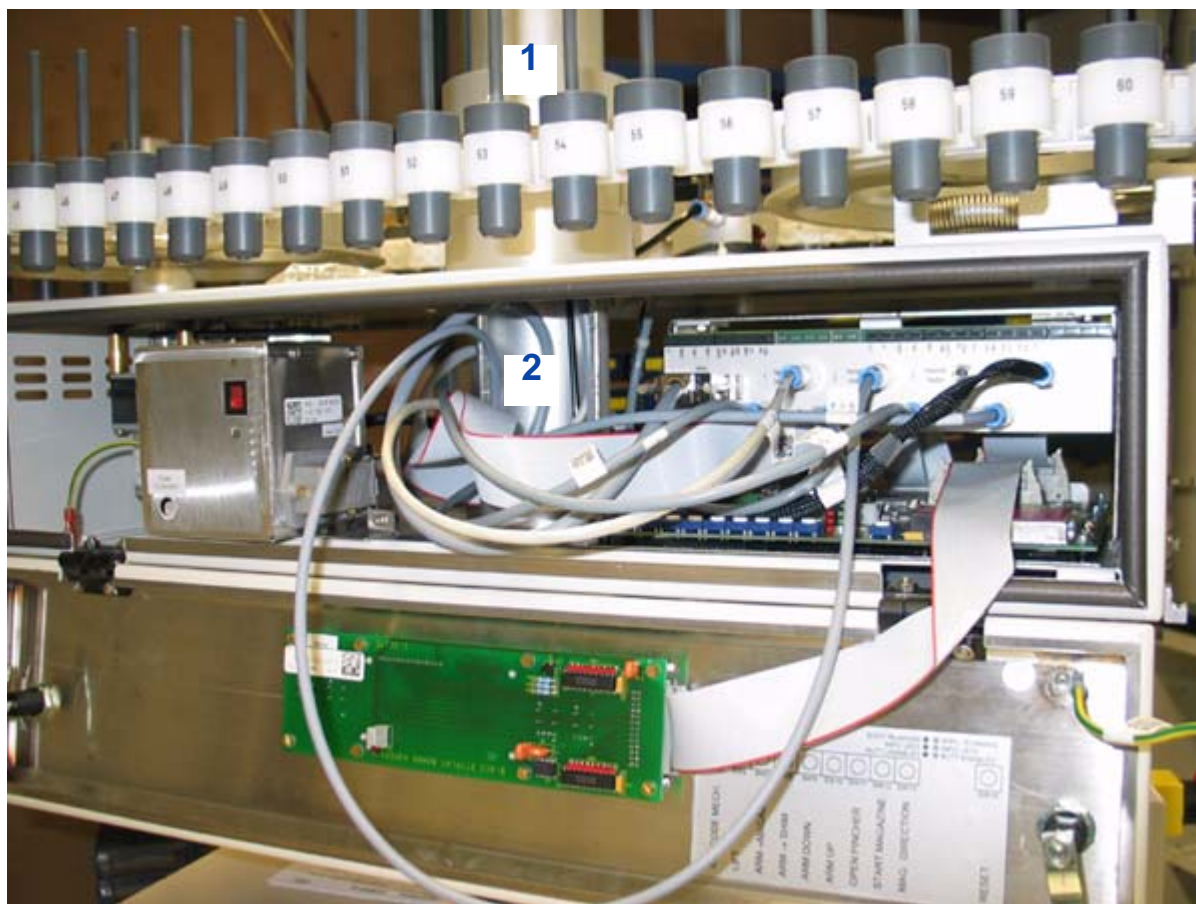

Figure 3.5. Front view of the Automatic Sample Changer

Preparing the Column for Assembly

3.5

Slide the clamp cover and the square clamp (see [Figure 3.6](#)) over the bottom of the round column towards the bottom of the cabinet. The clamp cover should be next to the cabinet and the square clamp underneath the cover. Do not tighten the clamp.

To prepare the square column piece for mounting, pull the cables and pneumatic hoses out of the inside of the top of the square column piece. Insert these cables and hoses (upwards) through the round column piece. Reach through the cabinet opening and the side opening of the round column piece and pull the cables and hoses through until the ends are outside the side opening of the round piece (see [Figure 3.6](#)).

Measure the distance from the top of the shim system of the magnet to the ground. If the column is fitted with a base plate, then measure from the top of the shim system to the top of the base plate (see [Figure 3.1](#)). In either case subtract 0.5 cm from the measurement. This is the length that the column needs to be from the bottom of the square column piece to the top of the belt of the cabinet. You will need this measurement for the assembly of the column.

Assembling the Column

3.6

Refer to [Figure 3.6](#) for this step.

Assemble the two column pieces, placing the square piece over the round piece. Using the measurement obtained in ["Mounting the Cabinet" on page 18](#) align the distance of the bottom of the square piece to the top of the belt of the cabinet. It is **important** for the proper operation of the sample changer that this length matches the distance from the ground (or the top of the base plate for the column assembly) to the top of the shim system minus 0.5 cm.

Fasten the two column pieces together by placing the four vertical locking mechanisms in the inside corners of the square column piece. Recheck the length of the column as described above, and adjust if necessary.

Slide the square clamp downwards until it sets over the locking mechanisms. Tighten the clamp securely. Slide the clamp cover downwards until it sets firmly against the square clamp.

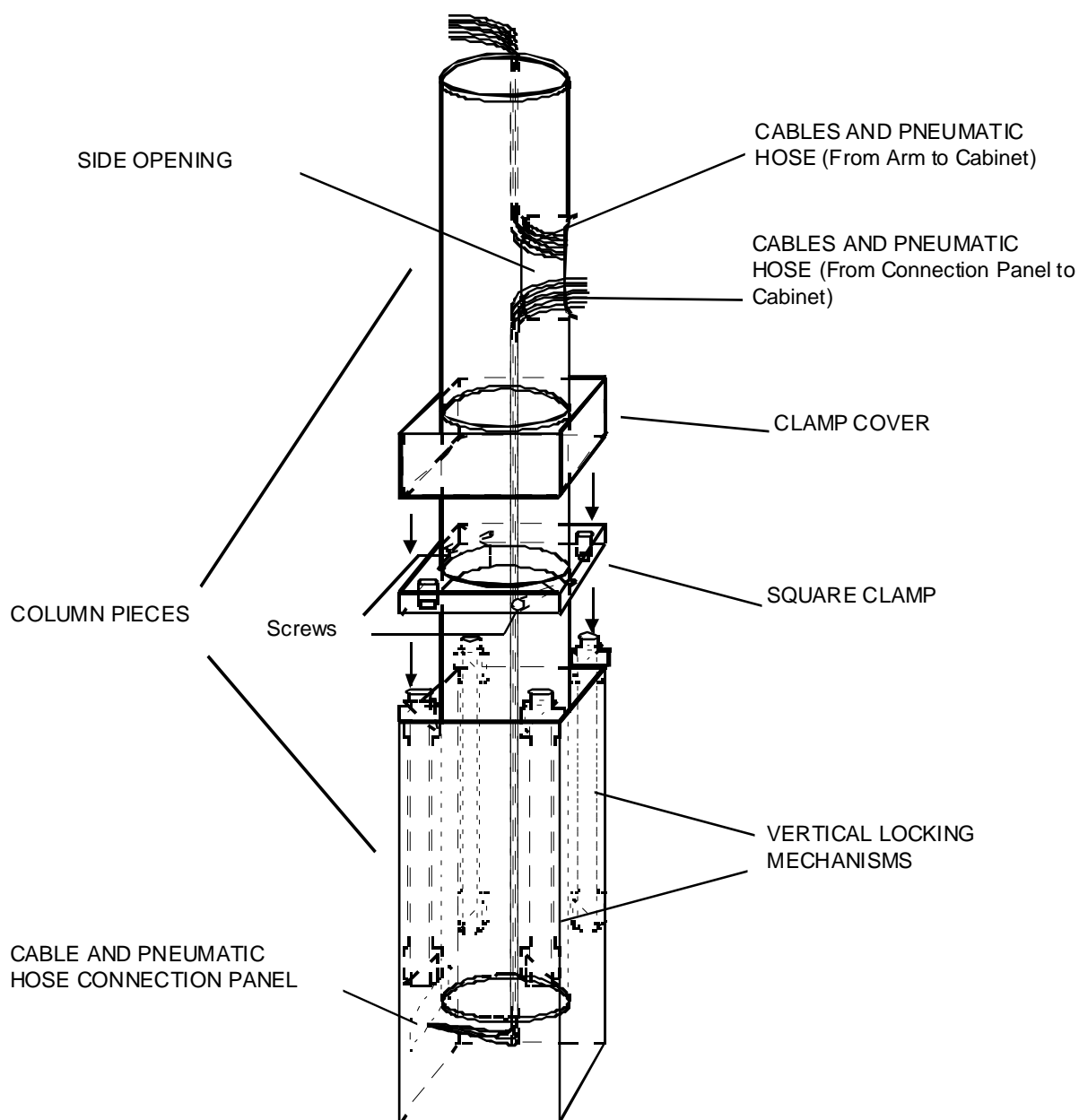

Figure 3.6. Column Assembly

Mounting the Column Assembly to the Magnet

3.7

Fasten the two top adjustable arm assemblies to the round portion of the column.

For Magnets without N2 Towers:

Remove the bolts and brackets (see [Figure 3.7.](#)) from the magnet end of the adjustable arms and place them next to the magnet lifting lugs.

Mounting the Column Assembly to the Magnet

Lift the column assembly upwards so that the cabinet is on the top. Secure the two top adjustable arms to the lifting lugs of the magnet with the bolts and brackets.



Figure 3.7. Adjustable Arm Assembly for Magnets without N2 Tower

For Magnets with N2 Towers:

Remove the screws from the adjustable arm assemblies for N2 magnets (see [Figure 3.8](#)), and move the arm assemblies and column to the N2 towers. Place the outer half of the fastening rings around the N2 towers and screw the fastening rings together. Do not tighten the rings until you have completed the step below.



Figure 3.8. Adjustable Arm Assembly for Magnets with N2 Tower

Regardless if you have N2 tower or not, the column should be turned so that the connections at the bottom are directed towards the magnet (see [Figure 3.11](#)).

Mounting Instructions

Tip: It is easier to accomplish this step with two people, one to hold the column vertical and the other to secure the adjustable arms.

Note: If the magnet has Vibration Dampers and the column uses a support pictured in **Figure 3.12**, then the column must be leveled at this time (as described in **"Securing the Bottom of the Column Assembly" on page 23**) before mounting the pneumatic arm assembly.

Mounting the Pneumatic Arm Assembly

3.8

Slide the pneumatic arm resting ring (see **Figure 3.9** - C) over the top of the round column piece and let it rest on the top of the cabinet (don't tighten it). The resting ring gives a vertical support to the arm which can still rotate horizontally. A key and slot system allows for a free rotation of the arm of about 90° around the column. This is necessary on wide bore magnets where the arm has to swing away from the top opening when handling larger samples.

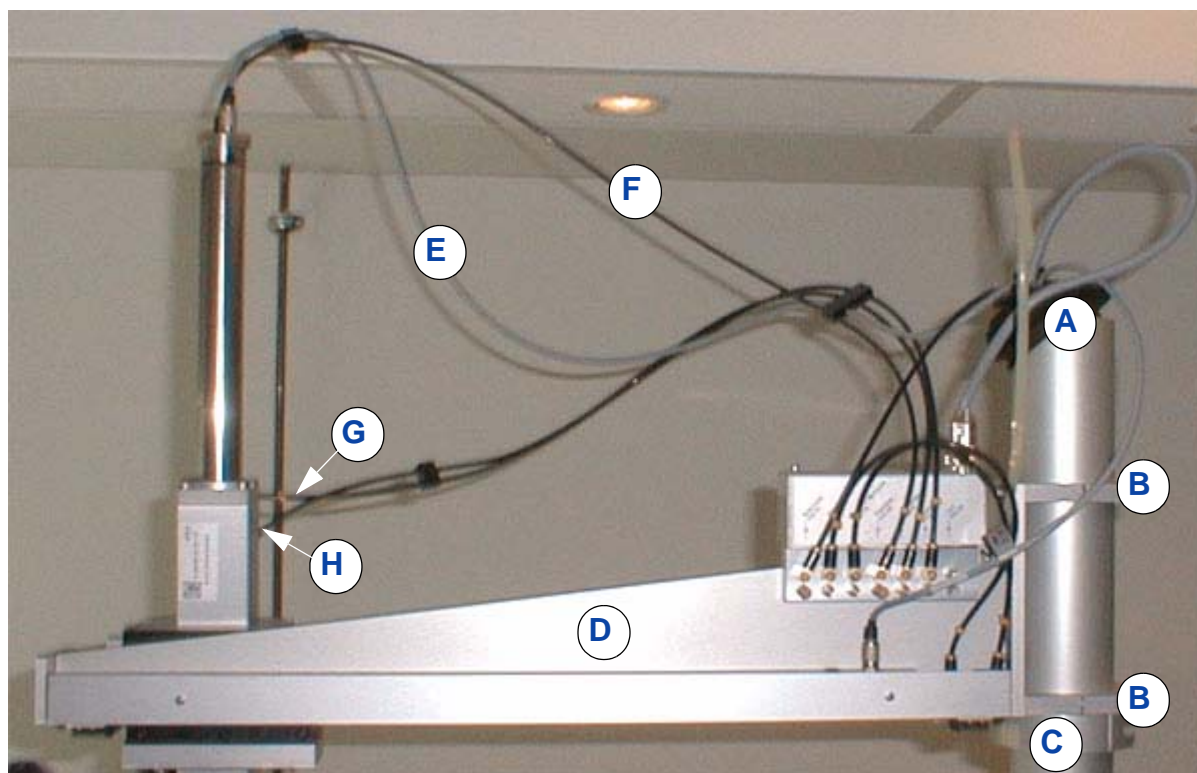

- | | |
|-------------------------------|---|
| A. Flexible Rubber Sleeve | E. Vertical Motion & Pincher Switch Connections (cable # 1) |
| B. Fixture Rings | F. Pincher Air Hose (pneumatic hose # 3) |
| C. Pneumatic Arm Resting Ring | G. Downward Motion Air Hose (pneumatic hose # 4) |
| D. Pneumatic Arm Assembly | H. Upward Motion Air Hose (pneumatic hose # 5) |

Figure 3.9. Arrangement of Pneumatic Arm Assembly

Place the pneumatic arm assembly over the top of the column, sliding the two fixture rings (see **Figure 3.9** - B) over the round column piece. Tighten the rings just enough to keep the pneumatic arm assembly from sliding down.

Rotate the pneumatic arm assembly (see [Figure 3.9 - D](#)) until the pincher is directly over the shim system (see [Figure 3.10](#)). The distance between the bottom of the pincher (when the cylinder is in the down position) and the top of the shim system should be 3 cm. Adjust this distance by loosening the fixture rings and raising or lowering the pneumatic arm assembly. When the correct distance is achieved, tighten the fixture rings. Raise the pneumatic arm resting ring until it rests firmly against the bottom fixture ring and tighten it securely.

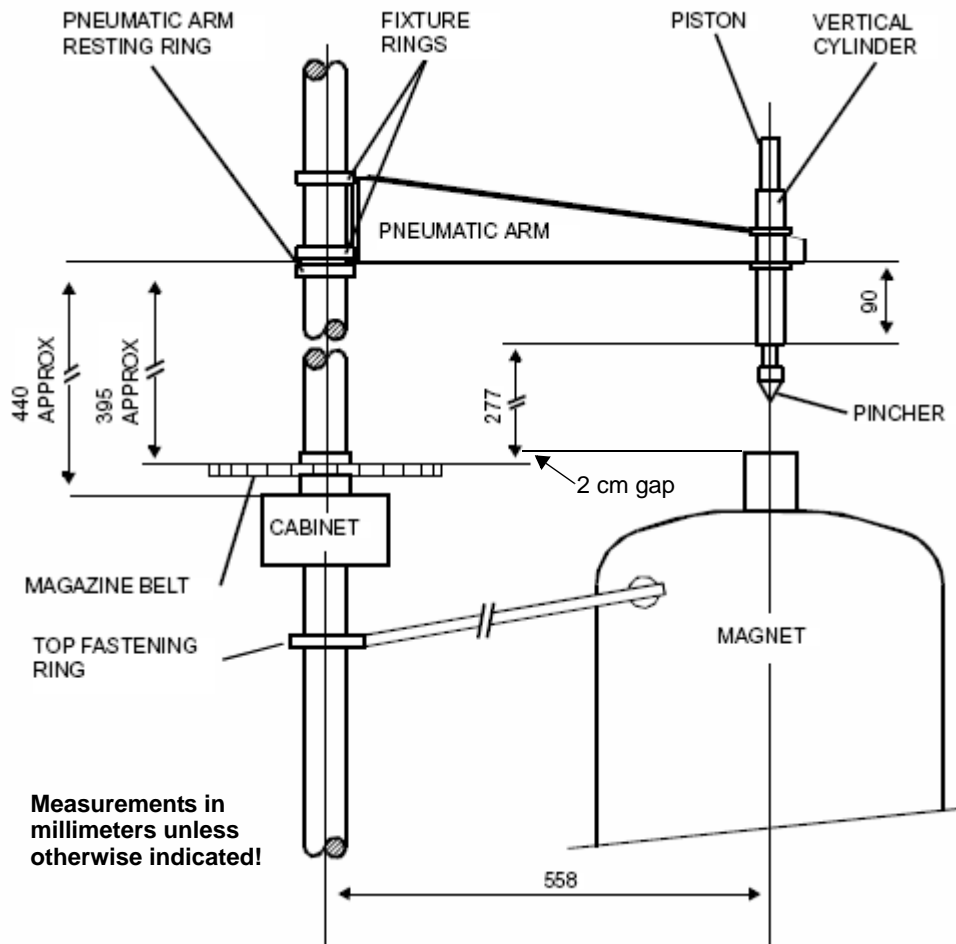

Figure 3.10. Position of the Pneumatic Arm on the Column

Securing the Bottom of the Column Assembly

3.9

Using a level measuring device, check to see if the round column piece is vertically level. Move the bottom of the column assembly as needed to adjust the level. Once this is accomplished, connect the two remaining (bottom) adjustable arm assemblies to the electrical and pneumatic connector plate on the square column piece. Connect the other end of the arms to the legs of the magnet using the round clamps (see [Figure 3.11](#)).



Figure 3.11. Adjustable Arm Assembly for Bottom of B-ACS

If you are mounting a sample changer on a magnet that has **Vibration Dampers**, then the bottom of the column sets on the support as shown in **Figure 3.12**. To position the column so that it is vertically level, turn the adjustable arms to move the column. When the support is used, the bottom adjustable arms are not required.



Figure 3.12. Mounting Sample Changer to Magnet with Vibration Dampers



Before using the sample changer, perform the fine adjustment procedure for the pincher as described in ["Fine Adjustment Procedures" on page 37](#).

Connecting the Hoses and Cables

3.10

Slip the pneumatic hoses and electrical cables from the arm to the cabinet through the flexible rubber sleeve down, through the column to the side opening into the cabinet (see [Figure 3.5](#)). Connect the pneumatic hoses and the electrical cables from the pneumatic arm assembly, and from the connector panel on the bottom of the column assembly (see [Figure 3.6](#)) to the pneumatic hose connection assembly and electrical sensor connector assembly in the cabinet (see [Figure 3.9](#), [Figure 3.13](#), [Figure 3.14](#), [Figure 11.2](#), and [Figure 11.12](#)).

Important: All of the electrical cables, electrical connections, air hoses and air hose connections are number-coded. Plug the numbered cable/hose into the corresponding connection (for example: cable # 6 to connector # 6 on the Sensor Connector Assembly).

When fixing air hoses allow for a stress free loop in order to avoid hoses being squashed at narrow bends or corners.

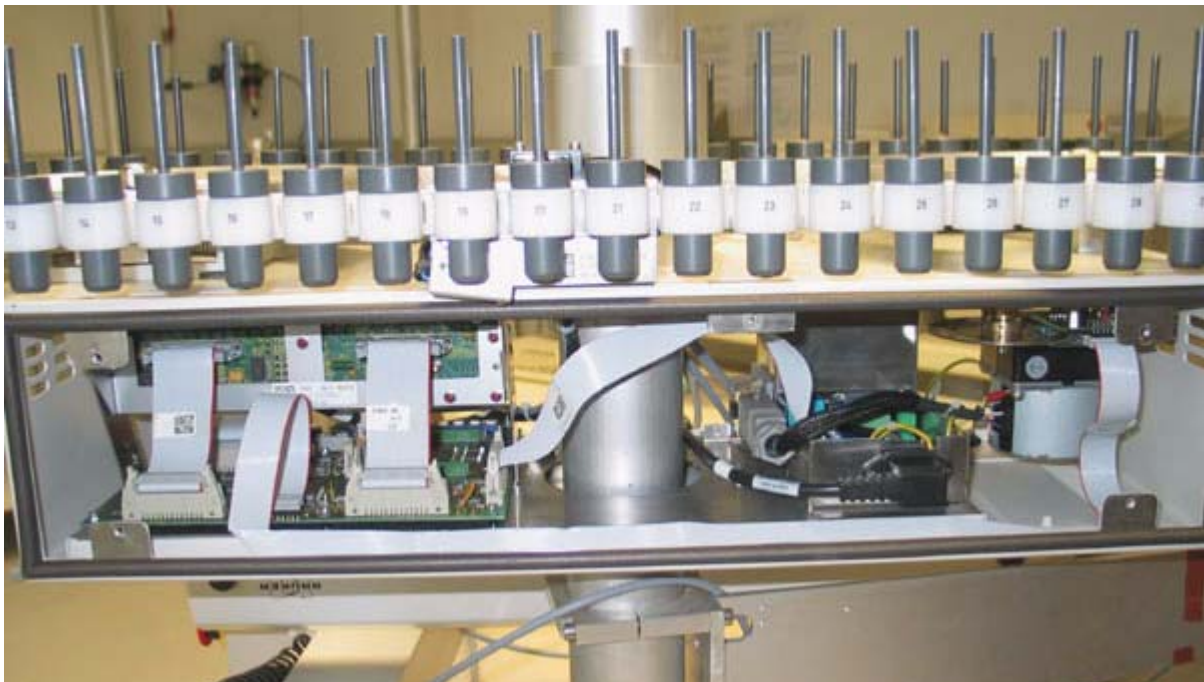
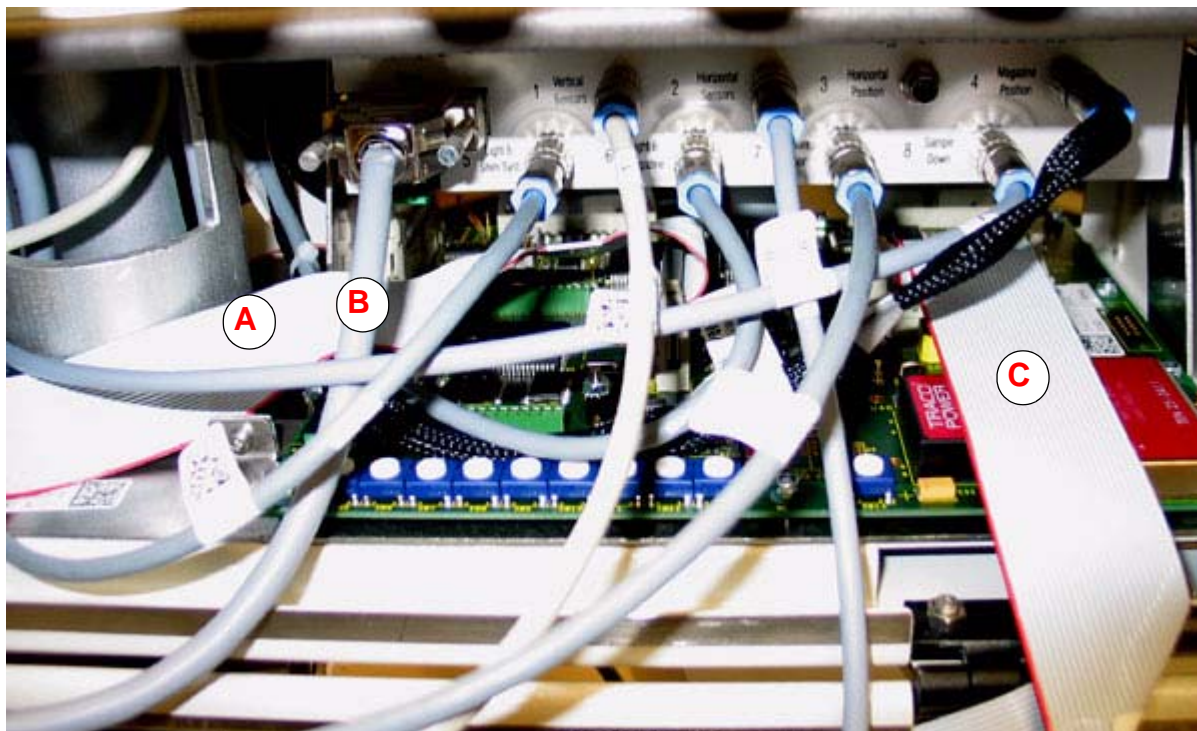

Figure 3.13. Rear View of the Automatic Sample Changer

Mounting Instructions



A. RS232 Cable

B. Valves Cable

C. Display Cable

Figure 3.14. Partial Front View of Column and Cabinet

Remote Hose Connections

3.10.1

The pressure of the compressed air supply should be between 4 and 6 bar (50-60 PSI). Connect the one-way valve supplied in the accessory kit to the sample lift valve on the Cable and Pneumatic Hose Connection Panel as shown in **Figure 3.15** and **Figure 3.16**. Add the needle valve supplied in the accessory kit between the sample lift valve and the BSMS.

Watch the direction of the needle valve!

Assemble the pneumatic tubing on and around the sample changer as shown in **Figure 3.15**.

Open the compressed air supply.

Using the regulator at the rear of the lower column assembly, set the air pressure to **4,0 bar** (50 PSI).

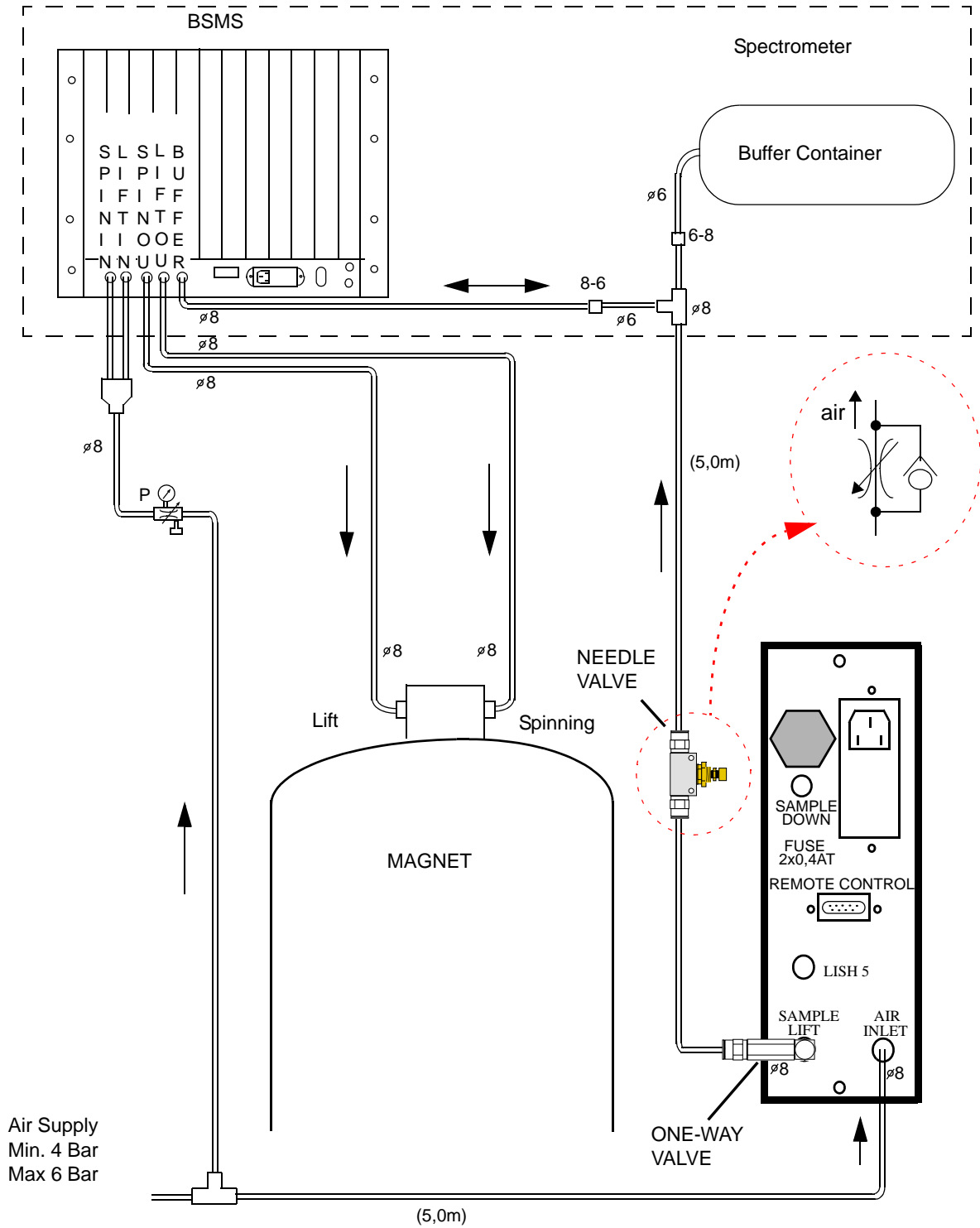

Figure 3.15. Pneumatic Connections to Magnet and Console.

Mounting Instructions

Connecting the Mains and RS232 Cable

3.10.2

Connect the 230V main power cable from an electrical outlet to the Cable and Pneumatic Connection Panel. Connect the connection panel to the cabinet end of the 230V power cable to the Mains connector as shown in **Figure 3.13**.

Connect cable # 5 to LISH 5 on the Cable and Pneumatic Hose Connection Panel. Connect the other end of the cable to the Light Barrier for the Shim System as shown in **Figure 3.4**. For magnets with the BOSS 1 and BOSS 2 Shim Systems (see **Figure 3.3**) the cable is connected directly to the BSMS SLCB board, Sample Control connector.

Connect the RS232 connector and cable from the computer to the Remote Control 9-pin female connection on the Cable and Pneumatic Hose Connection Panel.

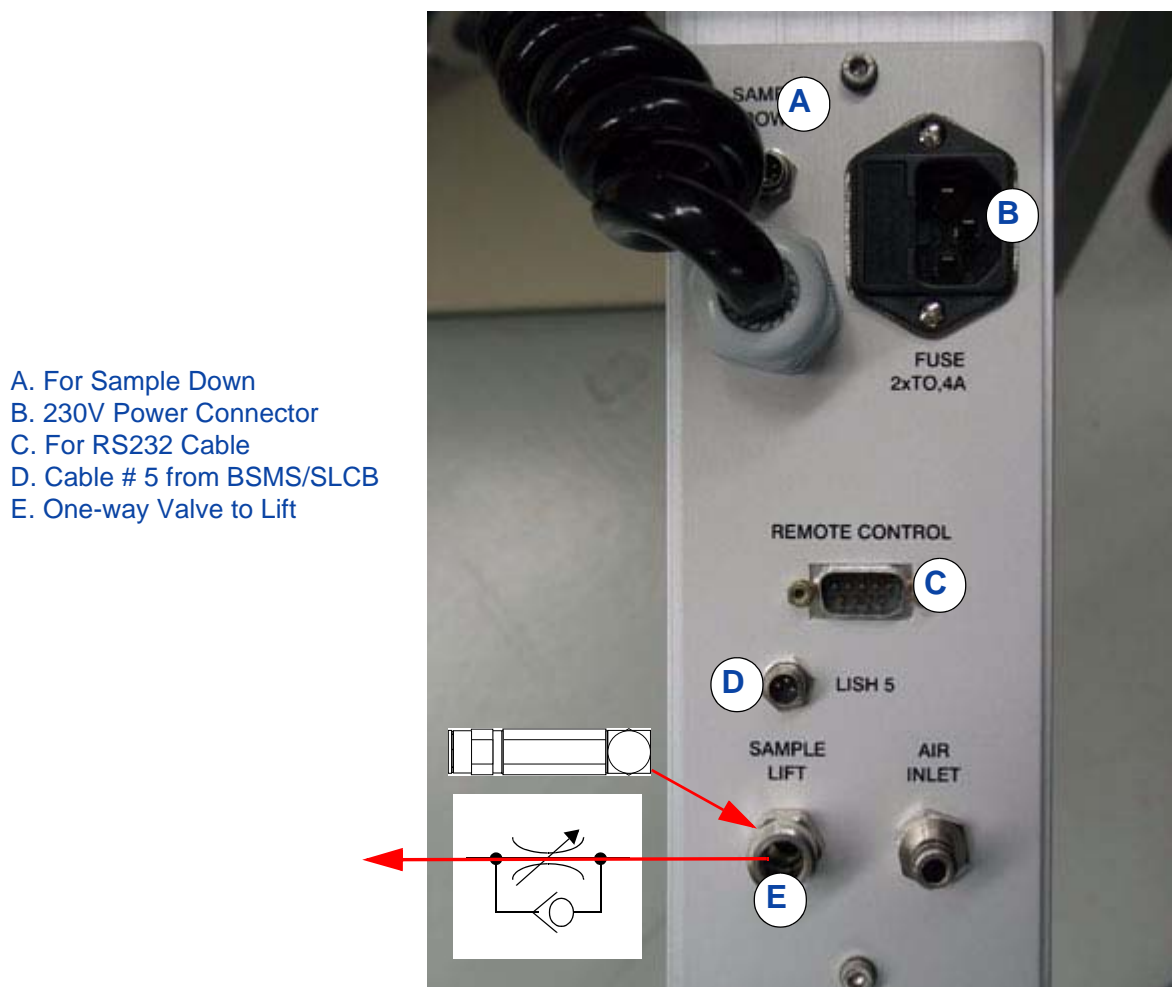

Figure 3.16. Cable and Pneumatic Hose Connection Panel

Description of Input and Output Locations

3.11

Refer to **Figure 3.16.**

Input: Mains connection - The 230V Connector

Air Input - Air Inlet

Light Barrier Shim System Input

Output: Sample lift air output - Sample Lift. Parallel with buffer.

Input and Output: RS232 Cable connection to computer - Remote Control

Mounting Instructions

Settings and Adjustments

4

General

4.1

This chapter will lead you through the mechanical settings, fine adjustment procedures, pneumatic cylinder setting, and final setup of the automatic sample changer. These adjustments should be made only after the sample changer has been mounted in accordance with the instructions in chapter 3, "[Mounting Instructions](#)".



Attention: There are no safety measures available that will prevent unauthorized motions (e.g. magazine motion when the closed pincer is down)! Thus it is possible to break glass tubes when a manual motion is carried out! Remove all sample tubes from B-ACS before using the manual motion control. When it is absolutely necessary to use a tube, then use empty glass tubes or dummy samples!

Mechanical Settings

4.2

If you do not have BOSS1 or BOSS2: Before making the following adjustments, make sure that the light barrier cylinder has been properly fitted on the top of the shim system and that cable #5 is connected to the Cable and Pneumatic Hose Connection Panel (refer to "[Connecting the Hoses and Cables](#)" on page 25).

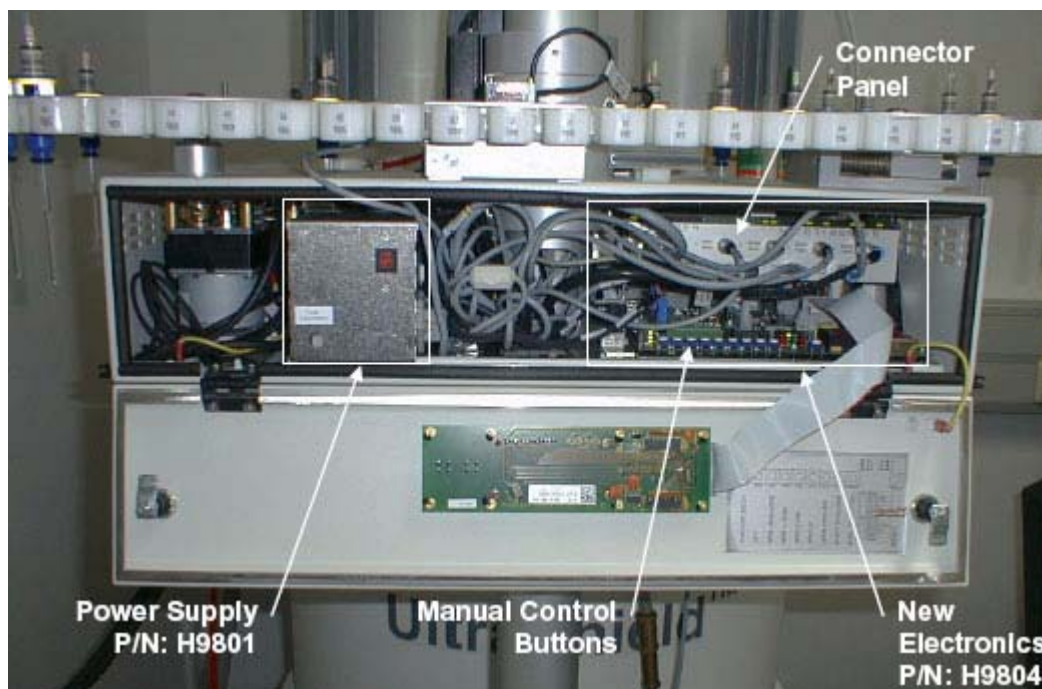

Figure 4.1. Cabinet View Showing Main Components

Make sure the mains connector is plugged into the connection panel of the square column piece (see [Figure 3.16](#)). Rotate the red security switch outwards and push the black start switch (see the figure below). Press one of the manual control buttons right after turning the power on and hold it down for at least 5 seconds before releasing it. All mechanical functions can now be switched manually by pressing the manual control buttons on the pneumatic assembly ([Figure 4.1](#)).

Refer to the B-ACS Troubleshooting manual (P/N Z31723) for further information on the manual control buttons.



Figure 4.2. Security Switch

Pneumatic Arm Adjustment

4.2.1

For all of the following settings use a 5 mm ϕ dummy sample (supplied with the B-ACS accessories). The dummy sample looks like a sample with a spinner.

Caution: Make sure the arm is in the up position before moving inwards (towards the magazine) or outwards (towards the magnet).

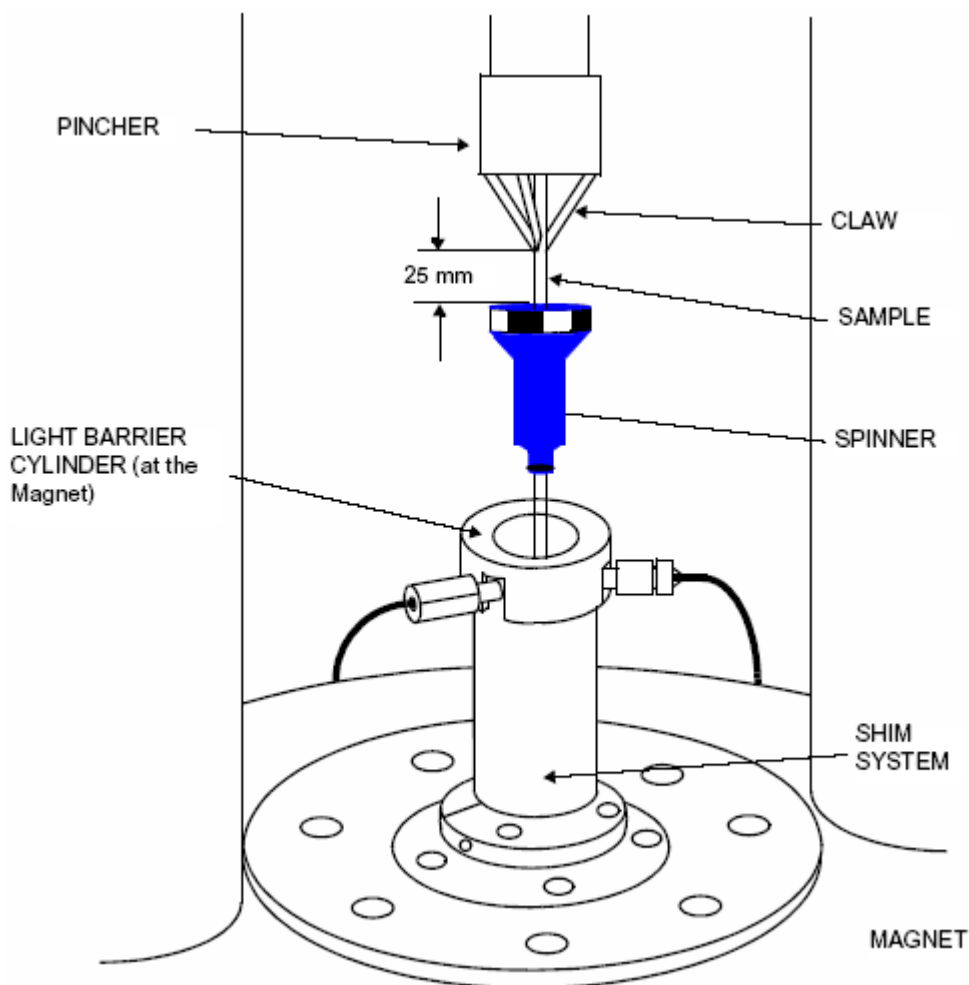

Figure 4.3. Sample in Pincher on Top of Shim System

Perform the following tasks with the manual switches shown in **Figure 4.1.**:

Arm up. (ARO)

Pincher Open. (ZAUF)

Put the sample in the pincher and close it.

The arm should now be holding the sample. Adjust the sample so that it hangs loosely (**Figure 4.3.**, **Figure 4.4.**).

Now move the sample to just over the light barrier cylinder:

Arm outwards. (ARSH)

Arm down slowly. (ARU)

The sample should be just over the light barrier cylinder, but probably not centered.

The sample now has to be maneuvered to the exact center of the shim system, while the column is kept in the upright position. To accomplish this, adjust the dis-

tance between the sample changer and the magnet by rotating the four adjustable arm assemblies (**Figure 3.1**, **Figure 3.8**). Adjust the arm direction by loosening its fixture on the column. Let down the sample in short steps while adjusting. If the pincher seems to get too close to the light barrier cylinder, then the whole arm has to be lifted.

Once the sample is centered, complete the following steps to verify the correct arm position:

Arm down. (ARU)

Lift on. (LIVE)

Pincher open (ZAUF).

Let the sample float a few seconds on the cushion of air to allow it to stabilize.

Close the pincher (by releasing the ZAUF switch).

The arm position is correct when the pincher holds the sample 25 mm above the spinner. If necessary, adjust the arm's height and repeat the sequence: lift on, pincher open, wait, pincher closed, until the setting is correct.

Cabinet and Magazine Belt Adjustment

4.2.2

Following the pneumatic arm setting procedure, keep the sample in the pincher in the same position it was grasped after the sample lift. Perform the following steps to check the position of the cabinet with the magazine belt:

Sample lift off (LIVE).

Arm up (ARO).

Arm to magazine (ARMA).

Arm down slowly (ARU).

Rotate the cabinet slightly if the sample, when approaching the magazine, is not centered perfectly in the sample holder of the magazine belt (see **Figure 4.5**).

Move the arm further down.

If the inward position of the vertical cylinder is not correct, then see section "**Vertical Cylinder Adjustment**". If the spinner tip edge gets too close to the sample holder (less than 3 mm) move the cabinet further down. The correct distance between the spinner top edge and the magazine should be approx. 2-3 mm (see **Figure 4.4**) when the vertical arm is completely down.

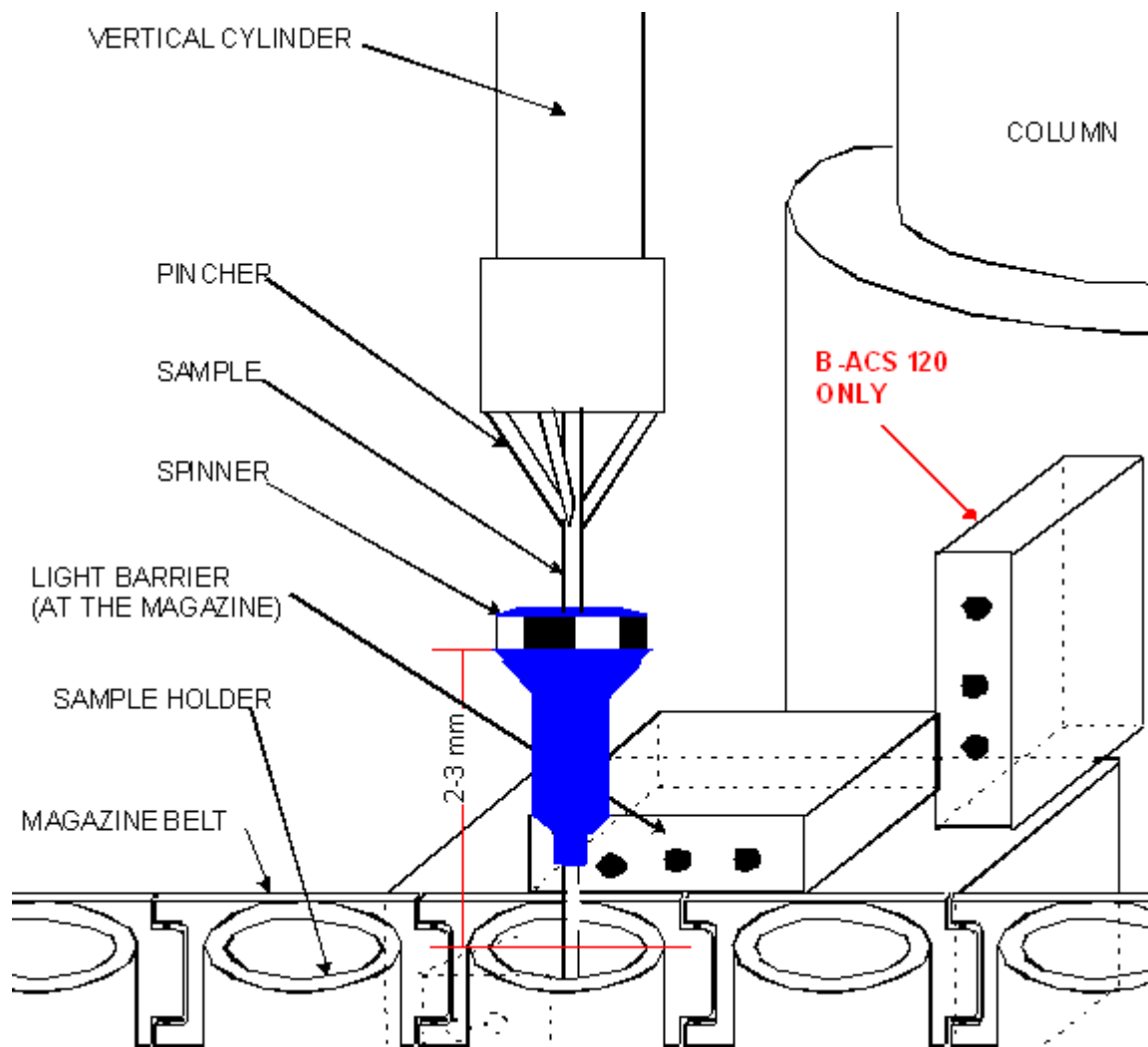

Figure 4.4. Sample in Pincher on Tip of Magazine Belt

Vertical Cylinder Adjustment

4.2.3

The vertical position of the vertical cylinder is factory set and normally does not need any adjustment. However, if it becomes absolutely necessary, the cylinder can be shifted vertically and horizontally by loosening the support bracket (see [Figure 4.5.](#)). Generally the vertical position should be kept at a 90 mm position.



Caution: Do not tighten the support bracket too much, as this will damage the thin cylinder walls.

To adjust the horizontal position, loosen the two screws under the bottom support bracket (see **Figure 4.5**). To obtain compensation for guide play, press the top and bottom brackets together when tightening the mounting screws.

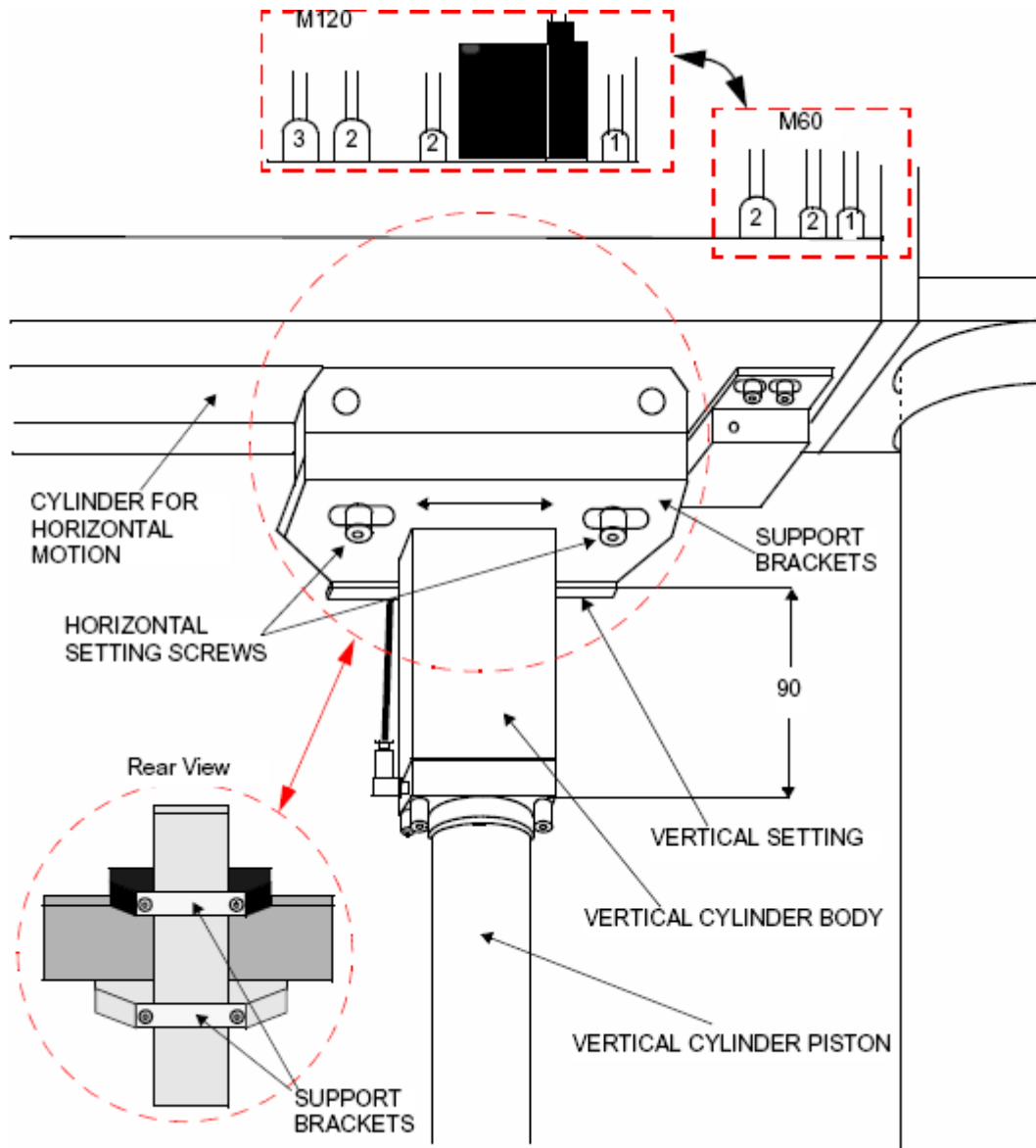

Figure 4.5. Mounting the Vertical Cylinder

Fine Adjustment Procedures

4.3

The following procedures are used as:

- An aid in making a final check of the Sample Changer.
- As a check list for readjusting a running Sample Changer at regular intervals.

Prepare the Sample Changer as Follows:

1. Switch the power off using the red security switch pictured in see **Figure 4.2.**
2. Pull the red security switch outwards and push the black start button to turn the power back on.

To enable the manual control buttons, press one of them (e.g. BarcValve) right after turning the power on and hold it pressed for 5 seconds before releasing it. Now you can use the manual control buttons (Figure 4.1.**) to perform the following functions (the correct switches to use are in parenthesis):**

3. Arm Forwards (ARSH) - until the pincher rests over the shim system.
4. Obtain a dummy sample with a spinner.
5. Open the Pincher (ZAUF)
6. Place the sample in the pincher and release the ZAUF switch, allowing the pincher to close.
7. Lower the arm down (ARU) to over the shim system.
8. Turn the sample lift air (LIVE) on.
9. Open the pincher to release the sample (ZAUF).
10. Let the sample float for a few seconds to stabilize.
11. Close the pincher by releasing the ZAUF switch.
12. Turn the sample lift off.

The distance between the pincher and spinner should be 25 mm. If necessary, adjust the arm's height at the column (see **Figure 4.2.**).

Without changing the sample position in the pincher, perform the following steps:

13. Raise the arm slightly (ARO).
14. Check the concentricity of the spinner and the shim system. The concentricity can be adjusted by turning the bars of the adjustable arm assemblies (loosen the locking nuts (**Figure 3.1.**, **Figure 3.8.**), or by rotating the pneumatic arm.
15. Adjust the perpendicularity of the column by turning the bars of the bottom adjustable arm assemblies. Repeat steps 14-16 until an optimum position has been obtained.
16. Tighten the locking nuts and the fastening bolts of the four adjustable arm assemblies.

Settings at the Magazine

4.3.2

1. Raise the arm (ARO).
2. Move the arm towards the magazine (ARMA).

Caution: Carefully follow the movement of the sample to prevent collisions with any part of the cabinet or magnet.

3. Lower the arm (ARU) to the magazine belt.
4. Check the concentricity of the sample spinner and the sample holder on the magazine belt. The concentricity can be adjusted by turning (rotating) the cabinet assembly around the column slightly.

The sample spinner should not rest on the sample holder, but should stop approximately 2-3 mm over it (see see **Figure 4.4**). The sample has to fall into the sample holder when the pincher opens. If necessary adjust the cabinet vertical position.

Adjustment of the Tension of the Magazine Belt

4.3.3

New B-ACS have an automatic tension adjustment, therefore do not need to be adjusted manually.

If you have an older B-ACS without this feature, adjust the tension as follows:

The adjustment mechanism under the right carousel wheel (**Figure 4.6**) is used for adjusting the tension of the magazine belt. The tension should be increased only when the belt, when filled with samples, hangs more than 5 to 8 mm under the wheel line of the space between the two carousel wheels.



Caution: Excessive tension will damage the belt and wheel bearings.

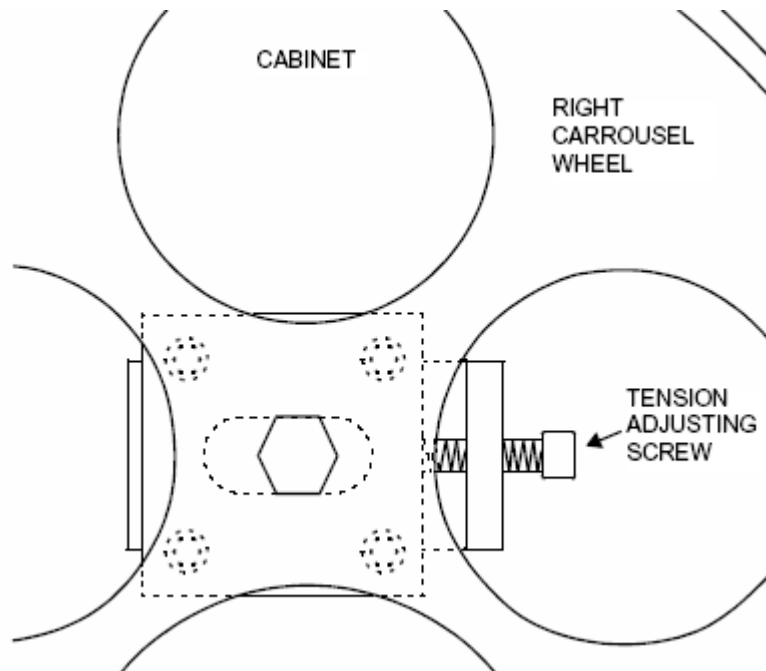

Figure 4.6. Top View of the Right Wheel and Tension Adjusting Mechanism.

Pneumatic Cylinder Settings

4.4

The speed of both the vertical and horizontal cylinder can be varied by regulating the outlet air flows of the cylinder supply connections. A small needle valve is fitted on the exhaust outlet of each of the magnetic valves 1, 2, 4, and 5 ([Figure 4.7](#)). The needle valves can be manually set to change the linear speed of the cylinder (by using a screwdriver).

Additionally the ORIGA horizontal cylinder is provided with two „end of course“ regulation needle valves to set the slowing down of the cylinder when reaching the end position (see [Figure 4.8](#)). However, **normally the factory default settings should not be changed!**

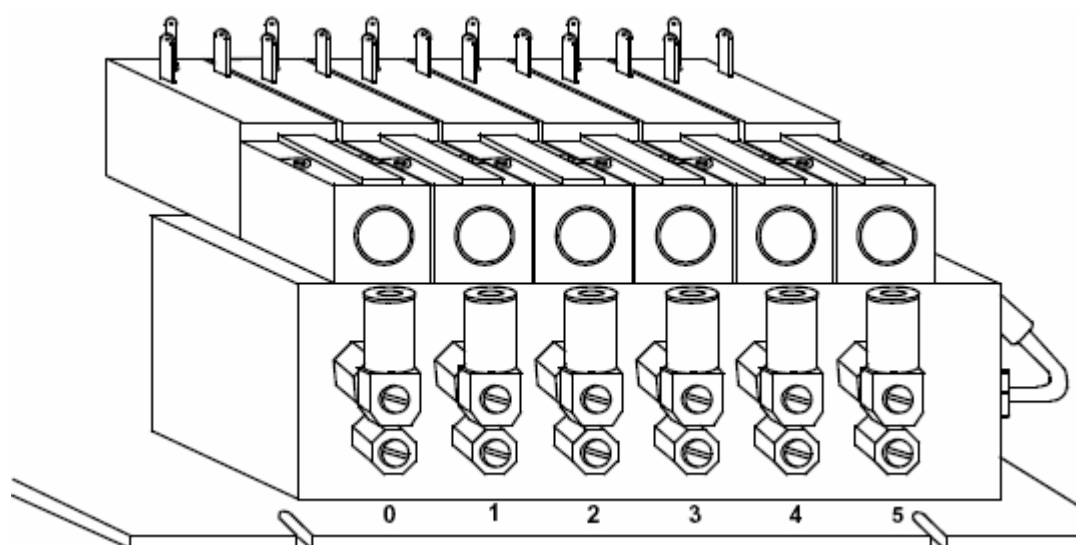

Figure 4.7. Outlet Needle Valves on the Cylinder Supply Connections

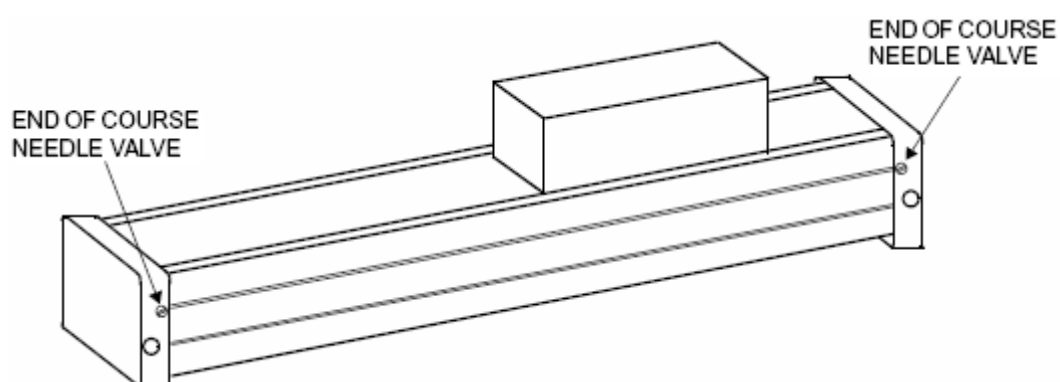

Figure 4.8. ORIGA Horizontal Cylinder Pneumatic Setting

Final Setup

4.5

Switch off the power by pushing the red security switch (**Figure 4.2.**).

Check the following connections:

- 26 lead flat cable to the RS232.
- 16 lead flat cable to the CDW socket.
- 26 lead flat cable from the front panel to the display connector.

Switch the power on by pulling the red security switch out and pushing the black start button (**Figure 4.2.**).

The initialization routine will automatically begin.

Operating Instructions

5

General

5.1

In the present version, the B-ACS 60 Automatic Sample Changer can handle a capacity of 60 samples for NMR measurements with superconductive magnets. The B-ACS 120 can handle 120 samples. The Sample Changer is linked to the host computer via a RS232 cable.

Front Panel Controls

5.1.1

The following controls are located on the front panel (**Figure 5.1**):

1. **Arrow Selection Buttons:** Push buttons for manual magazine motion.
2. **LC DISPLAY:** Used for the current status and for error messages.
3. **CONT:** A push button for continuation after a failure occurs.
4. **RESET:** A push button for system initialization.

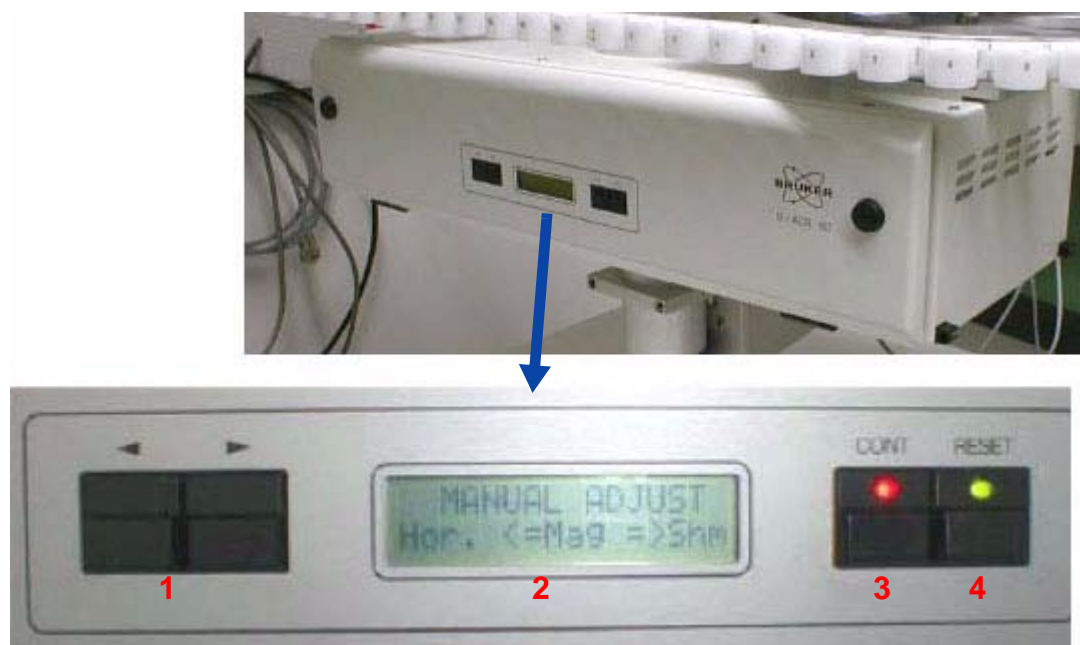

Figure 5.1. Front Panel of the Automatic Sample Changer

After installation, the sample changer needs to be connected to the host computer with a RS232 cable. The sample changer can then be started through use of the power switch.

The sample changer can be started either by pressing the power switch or by pressing the RESET button. The arm will then move to its stand-by position, i.e. the vertical cylinder up and the pincher on top of the opening at the magnet. The internal logic will then check the pincher status and if no sample is found in the pincher, will enter the READY waiting loop. If the pincher is holding a sample, the sample changer will try to place it in the actual magazine position (XX) or, if this one is occupied, into the next empty magazine position. The sample changer will then either, enter the READY loop and wait for an external command or, when all positions are occupied, interrupt the initialization and display error message No. 22 (No Free Magazine Position).

During the initialization the following message will be shown on the LC display:

**SAMPLE CHANGER
INITIALIZATION**

After the initialization, and during the READY loop, the following message is displayed:

**POSITION No.
(XX) or (XX / XXX)**

The XX represents the current magazine position.

The belt magazine of the B-ACS 60 sample changer has a maximum capacity of 60 samples. The B-ACS 120 has a maximum capacity of 120 samples. Gaps of one or more empty spaces are allowed between samples. This allows similar solvents to be grouped in contiguous positions in order to speed up the locking procedure.

Similarly, it is practical to leave a few free spaces between groups, which can be filled up at the last minute, with similar solvent samples. You may even do this when the sample changer is running.

The host computer controls various elements of the sample changer through the use of software commands. With a host running XWINNMR with a version less than 2.5 the sample changer is controlled from ICONNMR or SET & RUN. With a host running XWINNMR version 2.5 and greater the sample changer is controlled from ICONNMR only.

Test for Sample in Magnet (security test)

If a sample is present in the magnet, a further check will be performed to see if the sample is spinning and/or locked.

When a sample is found it will be removed and placed in the magazine. If no sample is found then a security test (SE) will be performed.

At the end of this test the normal sample changing procedure will begin. During this procedure the sample changer will automatically look for the next sample to be handled. The following message will be displayed during the normal changing procedure:

B-ACS BUSY!

(XX) or (XX / XXX)

Where **XX** indicates the current position of the magazine.

At the end of a sample changing procedure the following message will be displayed:

POSITION No.

(XX) or (XX / XXX)

Manual Motion (Control) of the Magazine Belt

5.5

Manual control of the movement of the magazine belt is accomplished by pushing the two buttons located on the side panel of the magazine. The push buttons are active only when the sample changer is not busy, i.e. idling in the ready loop.



When using the manual control beware of glass tubes moving in front of your fingers!

The Occurrence of a Failure

5.6

If a failure occurs during operation, the sample changer interrupts the current procedure, causing the red 'CONT' LED on the front panel to flash on and off. An error message, consisting of a code number and text, also show up on the display and an error signal is transmitted to the host.

To resume operation after the error has been corrected, press the 'CONT' button. The sample changer will then continue at the same point it had reached just before the failure occurred. On rare occasions it may be necessary to do a new initialization, if the above mentioned intervention did not correct the error.

General

6.1

The B-ACS is connected to the spectrometer using a RS232 communication port. This port can be used to send diagnostic commands to the B-ACS, e.g. to start test loops or single motions, to receive sensor signals, or for downloading a new application program firmware from the spectrometer host computer.

Refer to [Figure 11.11](#) for the baud rate settings.

Communication Path from the Host Computer

6.2

There are two possible tools that can be used for diagnostics/download:

RS Test

6.2.1

This tool can be opened from the ICONNMR test tools directory (e.g. c:\Bruker\topspin\prog\bin\utilities\testtools\rstest.cmd). Open the tool and select "B-ACS" to have access to the serial communication path to B-ACS.

This tool is only able to send commands to the B-ACS. Download of new application firmware is not possible with this tool.

Unitool

6.2.2

This tool is only available when you have the new electronics and XWINNMR 3.5 or higher. Start Unitool from the Service Tools directory (e.g. c:\Bruker\topspin\prog\bin\utilities\servtool\unitool\unitool.cmd) of ICONNMR-PC and enter the device name „bacs“. If this device is not known by UniTool, then enter the SBS address 1 and identifier B when queried from Unitool.

A menu will be displayed where you can select what you want to do, e.g. send a command to the sample changer.

Communication Path from a Windows Notebook Computer

6.3

The sample changer is normally connected directly to the spectrometer CCU extension via the serial interface Null modem cable. To connect it to your notebook computer, first make a note of the TTY location where B-ACS is connected to (standard TTY08). Disconnect the serial cable from the CCU extension and connect it to the notebook computer serial interface.

If it is necessary to extend the length of the interface connection, either use a one to one serial interface cable (TXD & RXD lines are not crossed over) together with the Null modem cable or use a longer Null modem cable.

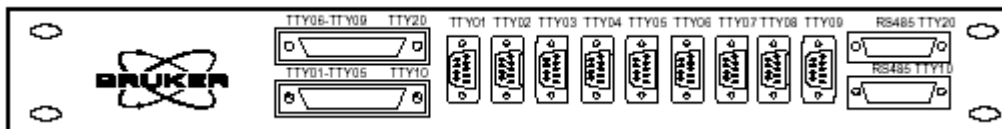

Figure 6.1. The CCU Extension

There are two possible tools that can be used for diagnostics / download. You can use either of these tools if you want to receive the debug buffer.

Hyperterminal

6.3.1

You can start the Hyperterminal, which is normally located in Start – Programs – Accessories – Hyperterminal. Set up the communication parameters as follows:

9600 baud, 7 data bit, Parity “marked”, 1 Stop bit; or,

9600 baud, 7 data bit, no parity, 2 stop bit (which is the same).

This tool is only able to send commands to the B-ACS (see the section **"List of Commands"**). Download of new application firmware is not possible with this tool.

Unitool

6.3.2

Start Unitool from the Unitool directory of your notebook computer and enter the SBS address 1 and identifier B when queried from Unitool.

A menu will be displayed where you can select what you want to do, e.g. send a command to the sample changer, or download new firmware etc.

Reconnecting the Serial Link Cable

6.3.3

After you have finished your work with the notebook computer (diagnostics, firmware download, etc.), quit the communication tool first, then disconnect the PC serial interface Null modem cable from your notebook computer and reconnect it to the spectrometer CCU Extension (standard TTY08).

Switching to Diagnostic Mode

6.4

In Diagnostic Mode, B-ACS enables low level debugging commands via an RS232 connection port. These commands are explained in the section **"Additional Commands Enabled in Diagnostic Mode"**.

1. Using Hyperterminal (see section [6.3.1](#)) or RSTool (see section [6.2.1](#)):

Enter the command <Esc>, then <enter>,
Press <Esc> & release the key,
Press dot (.) and release the key,
Press <enter>.

2. Using Unitool (see section [6.2.2](#) or [6.3.2](#))

Select the corresponding menu item from the B-ACS main menu in Unitool.

In both cases B-ACS responds by changing to Sample Changer Diagnostic Mode.

Switching to Operation Mode

6.5

After you have completed diagnostics you should switch back to operation mode as follows:

1. Using Hyperterminal or RSTool:

Enter the command sequence <Esc> ? <enter>

2. Using Unitool

Select the corresponding menu item from the B-ACS main menu in Unitool.

In both cases B-ACS responds by changing to Sample Changer Operation Mode.

B-ACS 60/120 Command Implementation

6.6

A command always consists of two letters which in some cases are followed by a space and a parameter. The space between the command and the parameter is essential. A command must always be terminated with <CR>. If this syntax is not respected, the sample changer gives the message: "Invalid Parameter" or "Invalid Command".

The response for any command is terminated with <CR><LF>. If no additional data is returned then the response is simply <CR><LF>.

The sample changer software commands have been divided into three modes:

1. Operation Mode

This is the actual sample changer operating mode in which complete sample exchange sequences can be run by a host computer.

2. Error Mode

This mode has only two commands: one to continue the program after an error has been observed, and one to move to the defined neutral position "HOME".

3. Diagnostic Mode

This mode offers the user a range of commands to test all the different sample changer functions.

Software Commands

The different commands are described in detail in the following sections.

List of Commands

6.7

The following list gives a detailed description of all operation commands in alphabetical order.

Normal Operation Mode

6.7.1

Instruction: **AP**

Format: AP<CR>

Description: **ASP Present**

Asks if the ASP hardware is connected and the firmware is available.

Reply: BDXX<CR><LF>

with

XX= 0 means: No ASP is present.

XX= 4 to 12. This is the number of barcode digits currently selected.

Instruction: **BD (Barcode Digits)**

Format: BD XX<CR>

Description: Sets the barcode length to 4, 6 or 12 digits.

Reply: <CR><LF>

Instruction: **BS**

Format: BS<CR>

Description: **Barcode Status**

Report of the selected barcode digit length and the associated code type.

Reply: BD 4<CR><LF> 4 digits, code 2 of 5 interleaved.
BD 6<CR><LF> 6 digits, code 2 of 5 interleaved.
BD 12<CR><LF> 12 digits, code EAN 13.

Instruction: **CL (Clear Label)**

Format: CL XXX<CR>

Description: Clear the stored label of the sample in position XXX.

Reply: <CR><LF>

Instruction: **CP**

Format: CP<CR>

Description: **Current Position**

Replies with the current magazine position.

Reply: PXX<CR><LF>

Position XX is always in the range of 1 to 60.

Software Commands

Instruction: **CX**

Format: CX<CR>

Description: Clears the „sample is measured“ flag for all magazine positions.

Reply: <CR><LF>

Instruction: **DC**

Format: DC X<CR>

Description: **Debug Control**

Enable or disable the debug report function via an additional debug SIO board (old electronics) or respectively the debug RS232 (new electronics).

DC 1 Enables debug RS232 (this is the default after a reset).

DC 0 Disables debug RS232.

Reply: <CR><LF>

Instruction: **DS**

Format: DS<CR>

Description: **Debug Status**

Report the status of the debug report function.

Reply: DC1<CR><LF> Debug RS232 enabled.

DC0<CR><LF> Debug RS232 disabled.

Instruction: **EC**

Format: EC X<CR>

Description: **Echo Control**

Replies with the received character back to the console.
X=0 Echo is set to inactive (default after a power on or reset).

X=1 Echo is to active. Available in Operation and Diagnostic Mode.

Reply: <CR><LF>

Instruction: **E1**

Format: E1<CR>

Description: **Eject Sample part one.**

Takes the sample out of the shim system and moves it to directly above the shim system.

Reply: <CR><LF>

Instruction:	E2
Format:	E2<CR>
Description:	<p>Eject Sample part two.</p> <p>Moves the sample from over the shim system to the sample changer's magazine and inserts it into the associated holder.</p> <p>Corresponds with the restore mode X that is selected (see the command RC). The restore behavior of the EJ command is as follows:</p> <p>X= 0 Standard restore mode. Automation stops when the sample source magazine position is occupied.</p> <p>X= 1 Moves to position 60/120 and starts the search from there for a new position. No report of the insert position is given.</p> <p>X= 2 Moves to position 60/120 and starts the search from there for a new position. Reports the insert position when the command is finished.</p> <p>X= 3 If the position is occupied it searches for a new free position in reverse order. No report of the insert position is given.</p> <p>X= 4 If the position is occupied it searches for a new free position in reverse order. Reports the insert position when the command is finished.</p>
Reply:	<p>Depends on the restore mode that is selected (see command RC). The reply is as follows:</p> <p>Restore mode 0, 1 and 3</p> <p>Reply: <CR><LF></p> <p>Restore mode 2 and 4</p> <p>Reply: PXXX<CR><LF></p> <p>Whereas XXX represents the insert magazine position of the sample.</p>

Instruction:	EJ
Format:	EJ<CR>
Description:	<p>EJect Sample from Magnet to Magazine</p> <p>Moves the sample from over the shim system to the sample changer's magazine and inserts it into the associated holder.</p> <p>Corresponds with the restore mode X that is selected (see the command RC). The restore behavior of the EJ command is as follows:</p> <p>X= 0 Standard restore mode. Automation stops when the sample source magazine position is occupied.</p> <p>X= 1 Moves to position 60/120 and starts the search from there for a new position. No report of the insert position is given.</p> <p>X= 2 Moves to position 60/120 and starts the search from there for a new position. Reports the insert position when the command is finished.</p> <p>X= 3 If the position is occupied it searches for a new free position in reverse order. No report of the insert position is given.</p> <p>X= 4 If the position is occupied it searches for a new free position in reverse order. Reports the insert position when the command is finished.</p>
Reply:	<p>Depends on the restore mode that is selected (see command RC). The reply is as follows:</p> <p>Restore mode 0, 1 and 3</p> <p>Reply: <CR><LF></p> <p>Restore mode 2 and 4</p> <p>Reply: PXXX<CR><LF></p> <p>Whereas XXX represents the insert magazine position of the sample.</p>

Software Commands

Instruction: **ES**

Format: ES<CR>

Description: Report **E**cho **S**tatus

Shows the current setting of the echo state.

Reply: **EC0**<CR><LF> Echo is inactive (default after Power On or Reset).

EC1<CR><LF> Echo is active.

Instruction: **EX** (Experiment)

Format: EX XXX<CR>

Description: Reads the barcode at position XXX. If it is an EAN 13 code, the first two digits which identify the experiment number are extracted.

Reply: EXX<CR><LF>

Whereas XX is the experiment number. E0 means that there is no EAN 13 label available.

Instruction: **HO** (**HO**me)

Format: HO<CR>

Description: The sample changer moves to its "HOME" position over the magazine. If a sample is hanging at the pincher, it is placed in an empty magazine position.

Reply: <CR><LF>

Instruction: **HP (Heater and Mixer Present)**

Format: HP<CR>

Description: Checks if the Heater & Mixer Unit is present. This is a dummy instruction, because the Heater and Mixer Unit was never released.

Reply: H0<CR><LF>

Instruction: **I1**

Format: I1 XXX<CR>

Description: **Inject Sample part 1.**

Takes the sample of magazine position XXX and moves it to directly above the shim system.

Reply: <CR><LF>

Instruction: **I2**

Format: I2 XXX<CR>

Description: **Inject Sample part 2.**

Inserts the sample from directly above the shim system into the magnet.

Reply: <CR><LF>

Software Commands

Instruction: **IJ**

Format: IJ XXX<CR>

Description: **InJ**ect Sample.

Takes the sample in magazine position XXX and inserts it into the magnet.

Reply: <CR><LF>

Instruction: **LL**

Format: LL<CR>

Description: Reads the barcode labels at the current magazine position in the inner and in outer magazine ring.

Reply: <CR><LF>

Instruction: **LS**

Format: LS<CR>

Description: Report **Lift Status**

Shows the current status of the lift control.

Reply: **NLO**<CR><LF> The lift is controlled through the sample changer (default after power on or reset).

NL1<CR><LF> The lift is controlled through the spectrometer's BSMS.

Instruction: **MS**

Format: MS<CR>

Description: **Measured Samples**

Reports the number of the measured samples in the sample changer magazine.

Reply: MSXX<CR><LF>

Whereas XX is the number of measured samples present.

As this instruction was only implemented for the NMR AutoPrep coupling, only the sample holder range from Nr. 1 to Nr. 60 is considered. This is also relevant for a B-ACS 120 sample changer (i.e. Nr. 1 to Nr. 120).

Instruction: **NL**

Format: NL X<CR>

Description: **No Lift**

Control of the lift pressure. Whereas:

X=0 The lift is controlled by the sample changer (default after a power on or reset).

X=1 The lift is controlled by the spectrometer's BSMS.

Reply: <CR><LF>

Instruction: **NM (Number of available Magazine positions)**

Format: NM <CR>

Description: Reports the number of available magazine positions.

Reply: NXXX<CR><LF>

Whereas XXX is the number of magazine positions that are available.

Software Commands

Instruction: **PD (Probe Down in magnet)**

Format: PD <CR>

Description: Reports if a sample is down inside the magnet.

Reply: P0<CR><LF> There is no sample in the magnet.
P1<CR><LF> There is a sample in the magnet.
P? <CR><LF> The sample down detection sensor is not populated.

Instruction: **RC**

Format: RC X<CR>

Description: **Restore Control**

Sets the specific restore mode. Where X corresponds to the restore mode list as followed:

X= 0 Standard restore mode. Automation stops when the sample source magazine position is occupied.

X= 1 Moves to position 60/120 and starts the search from there for a new position. No report of the insert position is given.

X= 2 Moves to position 60/120 and starts the search from there for a new position. Reports the insert position when the command is finished.

X= 3 If the position is occupied it searches for a new free position in reverse order. No report of the insert position is given.

X= 4 If the position is occupied it searches for a new free position in reverse order. Reports the insert position when the command is finished.

Reply: <CR><LF>

Instruction: **RS**

Format: RS<CR>

Description: **Restore Status**

Reports the status of the specific restore mode.

Reply: RCX<CR><LF>

Whereas the parameter X corresponds to the restore mode list of the command RC.

Instruction: **RP (Report measurement Position)**

Format: RP<CR>

Description: Reports the current measurement position.

Reply: P<number><CR><LF> or

P0<CR><LF> There is no sample in the magnet.

Instruction: **RL (Report Label)**

Format: RL XXX<CR>

Description: Reports the label of the sample to be measured (XXX indicates the magazine position).

Reply: L<number><CR><LF> or

L0 There is no label available.

Software Commands

Instruction: **RT (Report Tube ID)**

Format: RT<CR>

Description: Reports the Tube-ID of the sample in the magnet. This information is saved in a memory buffer when a sample is inserted into the magnet and deleted when the sample is withdrawn and ejected.

Reply: LXXXX<CR><LF>

Whereas

X= 0 No entry or an error.

X > 1 The Tube-ID of the sample.

Important !!!! XXXX can contain leading zeros !!!

Instruction: **SB**

Format: SB XXX<CR>

Description: **S**ample check at **B**arcode reader.

Checks if a sample is present in the barcode reader at magazine position XXX.

Reply: S1<CR><LF> Sample is present.

S0<CR><LF> No sample was found at position XXX.

Instruction: **SC**

Format: SC X<CR>

Description: **Screen Control.**

Sets the specific display mode, where X refers to the display mode list as follows:

X= 0 Standard display.

X= 1 Displays in addition the Tube-ID of the actual measured sample in the magnet.

X= 2 Displays in addition the source magazine position of the actual measured sample in the magnet.

With new electronics firmware greater than or equal to 20040526B16, X=1 and X=2 are the same. Both display the current position(s), the Tube ID and the source position of the actual measured sample in the magnet.

Reply: <CR><LF>

Instruction: **SE (SEcurity test)**

Format: SE<CR>

Description: Tests if a sample was left in the magnet. Starts the sample lift for 30 seconds to ensure that there is no sample in the magnet. If a sample is found, the sample lift is kept on and the message S1 is displayed (the lift can be turned off with the diagnostic command LD or by using the EJ command to eject the sample back onto the magazine). If no sample is found within 30 seconds, the lift is turned off and S0 is displayed.

Reply: S0<CR><LF> There is no sample in the magnet.

S1<CR><LF> There is a sample in the magnet.

Instruction: **SO (SOlvent)**

Format: SO XXX<CR>

Description: Reads the barcode at position XXX. If it is an EAN 13 code, it extracts digits 3 and 4 of the barcode which identify the solvent number.

Reply: VXX<CR><LF>

Whereas XX is the solvent number. V0 means that there is no EAN 13 label available.

Software Commands

Instruction: **SP** (Sample Present in position)

Format: SP XXX<CR>

Description: Checks if a sample is present in magazine position XXX.

Reply: S0<CR><LF> There is no sample present.
S1<CR><LF> There is a sample present.

Instruction: **SS**

Format: SS<CR>

Description: Screen Status
Reports the specific display mode.

Reply: SCX<CR><LF>
Whereas parameter X refers to the display mode list of the command SC.

Instruction: **ST**

Format: ST<CR>

Description: Checks whether a sample is present in the BST upper light barrier.

Reply: SX<CR><LF>
Where
X= 0 No sample is present.
X= 1 A sample is present.

Instruction: **TD**

Format: TD<CR>

Description: Locks the magazine motion keys on the front panel of the sample changer.

Reply: <CR><LF>

Instruction: **TE**

Format: TE<CR>

Description: Unlocks the magazine motion keys on the front panel of the sample changer.

Reply: <CR><LF>

Instruction: **UR (UseR)**

Format: UR XXX<CR>

Description: Reads the barcode at position XXX. If it is an EAN 13 code, it extracts digits 5 to 7 of the barcode which identify the user number.

Reply: UXXX<CR><LF>
Whereas XXX is the user number. U0 means that there is no EAN 13 label available.

Instruction: **VB (Version Build)**

Format: VB<CR>

Description: Reports the actual firmware version.

Reply: Built XX<CR><LF>
Where XX is the firmware build version.

Software Commands

Instruction: **VM** (Version Millennium)

Format: VM<CR>

Description: Reports the firmware version in the format JJJJMMDD.

JJJJ 4 digit year

MM 2 digit month

DD 2 digit day

Reply: JJJJMMDD<CR><LF>

Instruction: **VS** (VerSion)

Format: VS<CR>

Description: Reports the actual firmware version.

Reply: yymmdd<CR><LF>

Instruction: **XL**

Format: XL XXX<CR>

Description: Releases position XXX for removal through NMR *AutoPrep*.

Reply: <CR><LF>

Instruction: **ZY** (Zero Yell)

Format: ZY<CR>

Description: Repeats the last reply sent.

Reply: Last reply<CR><LF>

Instruction: **ESC.** (ESCape key + ".")

Format: ESC.<CR>

Description: Switches to diagnostic mode.

Reply: SAMPLE CHANGER DIAGNOSTIC MODE!

Instruction: **ESC?** (ESCape key + "?")

Format: ESC?<CR>

Description: Switches to operation mode.

Reply: SAMPLE CHANGER OPERATION MODE!<CR><LF>

Error Mode**6.7.2**

In the mode the following commands will be accepted:

Instruction: **CO** (COntinue)

Format: CO<CR>

Description: Continues the program at the point where it was interrupted when an error occurred. Normally retries the function which created the error.

Reply: <CR><LF>

Instruction: **HO** (HOMe)

Format: HO<CR>

Description: The sample changer moves to it's "HOME" position over the magazine. If a sample is hanging at the pincher, it is placed in an empty magazine position.

Reply: <CR><LF>

Software Commands

Instruction: **DE** (Debug Buffer Erase)

Format: DE<CR>

Description: Erases the internal debug buffer. This command is also available in diagnostic mode.

Reply: <CR><LF>

Instruction: **DR** (Debug Buffer Read)

Format: DR X<CR>

Description: Transmits the internal debug buffer via the command RS 232, where X represents the number of lines to be transmitted before a key action is expected. Without a parameter, the entire debug buffer will be transmitted at once. This command is also available in diagnostic mode.

Reply: Content of the debug buffer.

Additional Commands Enabled in Diagnostic Mode**6.8**

In the diagnostic mode all operation mode commands are accepted. The diagnostic mode command and the message „EXECUTED“ is sent before the <CF><LF> when the command is finished.

Note: Running test loops can be terminated with the CONT button if the red LED is on.

Instruction: **A1**

Format: A1<CR>

Description: Moves the horizontal cylinder over the inner ring position. If the vertical arm is down, it will move up before horizontal motion starts.

Reply: EXECUTED<CR><LF>

Instruction: **A2**

Format: A2<CR>

Description: Moves the horizontal cylinder over the outer ring position. If the vertical arm is down, it will move up before horizontal motion starts. This command is only available if the sample changer type is 120.

Reply: EXECUTED<CR><LF>

Instruction: **AD (Arm Down)**

Format: AD<CR>

Description: Moves the vertical cylinder downwards.

Reply: EXECUTED<CR><LF>

Instruction: **AU (Arm Up)**

Format: AU<CR>

Description: Moves the vertical cylinder upwards.

Reply: EXECUTED<CR><LF>

Software Commands

Instruction: **AS** (Arm to Shim)

Format: AS<CR>

Description: Moves the horizontal cylinder over the magnet shim system. If the vertical arm is down, it will move up before horizontal motion starts.

Reply: EXECUTED<CR><LF>

Instruction: **BT** (Barcode Test)

Format: BT<CR>

Description: Tests the barcode reader unit. Changes the channel with the Forward / Backward keys. The barcode will be continuously read and displayed on the LC display.

Reply: EXECUTED<CR><LF>

Instruction: **CA** (Code wheel Adjust)

Format: CA<CR>

Description: Tests the adjustment of the code wheel for magazine position detection. The code-wheel position will be continuously read and displayed on the LC display.

Reply: EXECUTED<CR><LF>

Instruction: **DT** (Display Test)

Format: DT<CR>

Description: Calls the display test program with the character pattern check routine. Press the CONT button to stop the test.

Reply: EXECUTED<CR><LF>

Instruction: **HL (Horizontal Loop)**

Format: HL<CR>

Description: Moves the horizontal cylinder from position A1 to AS and back in an endless loop.

Reply: EXECUTED<CR><LF>

Instruction: **LD (Lift Down)**

Format: LD<CR>

Description: Switches the sample lift off.

Reply: EXECUTED<CR><LF>

Instruction: **LB (Loop Back)**

Format: LB<CR>

Description: Moves the magazine backwards. Stops after each position is reached.

Reply: EXECUTED<CR><LF>

Instruction: **LF (Loop Forward)**

Format: LF<CR>

Description: Moves the magazine forwards. Stops after each position is reached.

Reply: EXECUTED<CR><LF>

Software Commands

Instruction: **LU (Lift Up)**

Format: LU<CR>

Description: Switches the sample lift on.

Reply: EXECUTED<CR><LF>

Instruction: **MB (Magazine Back)**

Format: MB<CR>

Description: Moves the magazine one position backwards.

Reply: EXECUTED<CR><LF>

Instruction: **MF (Magazine Forward)**

Format: MF<CR>

Description: Moves the magazine one position forwards.

Reply: EXECUTED<CR><LF>

Instruction: **MP (Magazine Position)**

Format: MP XXX<CR>

Description: Moves the magazine to position XXX.

Reply: EXECUTED<CR><LF>

Instruction: **OH** (Optic Horizontal)

Format: OH<CR>

Description: Test the horizontal positioning optic (necessary to reach position A2).

Reply: EXECUTED<CR><LF>

Instruction: **OM** (Optic Magazine)

Format: OM<CR>

Description: Tests the optic at the magazine which detects the samples in the magazine rings.

Reply: EXECUTED<CR><LF>

Instruction: **OS** (Optic Shim)

Format: OS<CR>

Description: Tests the optic at the magnet shim upper part.

Reply: EXECUTED<CR><LF>

Instruction: **PC** (Pincer Close)

Format: PC<CR>

Description: Closes the pincer.

Reply: EXECUTED<CR><LF>

Software Commands

Instruction: **PL (Pincer Loop)**

Format: PL<CR>

Description: Opens and closes the pincer in an endless loop.

Reply: EXECUTED<CR><LF>

Instruction: **PO (Pincer Open)**

Format: PO<CR>

Description: Opens the pincer.

Reply: EXECUTED<CR><LF>

Instruction: **PP (Probe down sensor Populated)**

Format: PP<CR>

Description: Obtains the analog value from the sensor population detection.

Reply: PXXX<CR><LF>

Where XXX is the analog value from 0 (= 0 Volt) to 255 (= 5V). Values between 100 and 200 represent a populated sample down sensor.

Instruction: **PT (Pressure Test)**

Format: PT<CR>

Description: Displays the current pressure sensor signal.

Reply: EXECUTED<CR><LF>

Instruction: **TL** (Test Loop)

Format: TL<CR>

Description: Complete sample changing test loop. The magazine moves until a sample is found. This sample is inserted into the magnet, ejected and put back into the magazine. Then a search for the next sample in the magazine will begin.

Reply: EXECUTED<CR><LF>

Instruction: **VL** (Vertical Loop)

Format: VL<CR>

Description: Moves the vertical cylinder up and down in an endless loop.

Reply: EXECUTED<CR><LF>

Instruction: **ESC?** (ESCape key + "?")

Format: <ESC>?<CR>

Description: Switches to operation mode.

Reply: SAMPLE CHANGER OPERATION MODE! <CR><LF>

List of Errors

7

Introduction

7.1

During the operation of the sample changer, two kinds of error messages may occur:

- Errors requiring user intervention.
- Errors in the communication between the sample changer and the host computer.

Before troubleshooting the explicit error messages described in the upcoming sections, you should be familiar with the debug possibilities described in the previous chapters! Nearly all the error messages make references to these basic skills or procedures.

Error Message Structure

7.1.1

Error messages basically consist of two parts:

- A two-digit error code
- An explicit error message

A RUB character (decimal 255) will precede any error message transmitted via the SIO channel.

General Checks before Detailed Troubleshooting

7.2

General checks to be performed BEFORE detailed troubleshooting:

- Is there enough main air pressure?
- Is the power supply working (fuses blown)?
- Is the sample changer initializing after reset (or is it doing nothing)?
- Is there an error message displayed at the B-ACS display? When yes, then note the error number *and* complete error message text before contacting Bruker Service for further help!

Before contacting the Bruker Help desk first annotate the following information:

- Spectrometer type and order number, e.g. AV400 HH123456
- Magnet Type, e.g. 600 MHz US+
- B-ACS part number and serial number, e.g. H1080, ECL05, #1234
- XWIN / ICONNMR version, e.g. 3.5 Patch Level 6

- Whether the sample changer has the new electronics.
- Whether the sample down detection box is installed.
- Error number and error text.

Having this information on hand will expedite handling when contacting Bruker Service!

Simple Errors with Error Number and Message

7.3

The following section contains a full list of error numbers and messages with comments. The messages are displayed and transmitted over the SIO channel.

Error 01: Insufficient Air Pressure

Meaning:	There is not enough main pressure for the pneumatic parts to work properly.
Possible reasons:	<ul style="list-style-type: none">• Main pressure supply is not sufficient. The sample changer has detected that the pressure left has reached the lower limit of 3 bar.• Under pressure – Switch is disconnected or not working. If you have new electronics you can monitor the pressure switch output to the electronics with the sensor LED “Low Press”.
Check the following:	Start the pressure test loop using the diagnostic command “ PT ” (see section 6.8) and open / close the pressure regulator in the B-ACS column. Watch the B-ACS display!
Technical background:	The sensor signal LOW_PRESS is wired using connector #7 at the connector panel.

Error 02: Downwards Motion Failed and Error 03: Upwards Motion Failed

Meaning:	The vertical cylinder motion was not detected as being in its “down” / “up” position.
Possible reasons:	<ul style="list-style-type: none">• Cable to the vertical cylinder is damaged.• End position switches in the vertical cylinder are damaged.• Valve is not working.

Error 02: Downwards Motion Failed and Error 03: Upwards Motion Failed

Check the following:

- Does the vertical arm move using the manual control buttons?
- Do the sensors work (only easy to check if you have the new electronics)?
- Use the diagnostic commands **AU**, **AD** and **VL** to find the error (see section [6.8](#)).

Technical background: The sensor signals UP and DOWN are wired using connector #1 at the connector panel.

The valve control signals run through the cable with the 15pin D-subconnector at the connector panel.

Error 04: Outwards Motion Failed and Error 05: Inwards Motion Failed

Meaning: The horizontal cylinder motion was not detected as being in its end position above the shim system or the magazine.

Possible reasons:

- The end position switches at the horizontal cylinder are damaged.
- Valve is not working.

Check the following:

- Does the horizontal arm move using the manual control buttons?
- Do the sensors work (only easy to check if you have the new electronics)?
- Use the diagnostic commands **A1**, **AS**, and **HL** to find the error (see section [6.8](#)).

Technical background: The sensor signals MAG and SHIM are wired using connector #2 at the connector panel.

The valve control signals run through the cable with the 15pin D-subconnector at the connector panel.

Error 06: Pincer Opening Failed and Error 07: Pincer Closing Failed

Meaning: The pincer did not open / close within a specified time.

Possible reasons:

- Cable to the vertical cylinder is damaged.
- Micro-switch inside the vertical cylinder is damaged.
- Valve is not working.

Error 06: Pincer Opening Failed and Error 07: Pincer Closing Failed

- Check the following:
- Does the pincer open with the manual control button?
 - Does the sensor work (only easy to check if you have the new electronics)?
 - Use the diagnostic commands **PO**, **PC** and **PL** to find the error (see section **6.8**).

Technical background: The sensor signal PINCER_OPEN is wired using connector #1 at the connector panel.

The valve control signals run through the cable with the 15pin D-subconnector at the connector panel.

Error 08: Carrousel Motion Failed

Meaning: The magazine did not move even when it was started by the controller.

Possible reasons: Motor or Driver-IC damaged.

- Check the following:
- Does the magazine move using the manual control button?
 - Does the motion direction change when pressing the MAG DIR button?
 - Does the positioning sensor (POSIG) work (only easy to check if you have the new electronics)?
 - Use the diagnostic commands **MB**, **MF**, **MP**, **LB** and **LF** to find the error (see section **6.8**).

Technical background: The sensor signal POSIG is wired using connector #4 at the connector panel.

The signals to start the motor and to set the direction are in the 26pin flat ribbon cable to the power supply box.

Error 09: Carrousel Position Undefined

Meaning: B-ACS tried three times to lock the magazine at the current position, but the magazine moved too far.

- Possible reasons:
- Magazine Positioning Switch is damaged / mis-adjusted.
 - If this error occurs during initialization without any movement of the cylinders, the power supply may be damaged. Check the fuses!
 - If the magazine does not stop, the magazine positioning switch is damaged.

Error 09: Carrousel Position Undefined

Check the following:

- Does the magazine move with the manual control button?
- Does the magazine lock at the next position after releasing the button?
- Does the positioning sensor (POSIG) work (only easy to check if you have the new electronics)?
- Use the diagnostic commands **MB**, **MF**, **MP**, **LB** and **LF** to find the error (see section **6.8**).

Technical background: The sensor signal POSIG is wired using connector #4 at the connector panel.

The signals used to start the motor and to set up the direction are in the 26pin flat ribbon cable to the power supply box.

Error 10: Sample Holder Not Empty

Meaning: B-ACS ejected a sample from the magnet and tried to place it in the magazine in an occupied position.

Possible reasons:

- Someone has inserted a sample manually in the corresponding holder.
- The reflex lights detect a sample at the magazine even when the position is empty.

Check the following:

- Does the sensor work (use the LED indicators at the housing and at the connector panel of the new electronics)?
- What is the range from where a sample is detected?
- Use the diagnostic command **OM** to find the error (see section **6.8**).

Technical background: The sensor signals SIGMA_INNER and SIGMA_OUTER are wired using connector #6 at the connector panel.

Error 11: Sample Detect At Magnet Failed

Meaning: B-ACS took a sample out of the magazine and tried to insert it into the magnet. The sample could not be seen at the shim top light barrier or it could not be detected down in the magnet (if you have the new electronics with a sample down detection box installed).

Possible reasons:

- Misaligned cylinders (the sample is inserted too far into the BST, or not far enough to interrupt the light barrier beam).
- Upper shim light barrier damaged.
- Sample down detection box not working properly.

Check the following:

- Insert / Eject samples using the manual lift button (or the diagnostic commands **LU** and **LD** - see section [6.8](#)).
- Observe the sensor LED's "SIGSH" (if you have the new electronics) and "Samp Down" (only if the sample down detection box is installed).
- Query B-ACS for the state of the upper shim light barrier using the command **ST** and the diagnostic command **OS** (see chapter [6](#)).

If the sample down detection box is installed:

- Observe the indicator at the box. The indicator will only be lit if a sample is down in the magnet. Refer to the corresponding installation manual.
- Query B-ACS for the state of the sample down sensor using the command **PD** (see section [6.7.1](#)).

Technical background: The sensor signal SIGSH is wired using connector #5 at the connector panel.

The sensor signal SAMPLE DOWN is wired using connector #8 at the connector panel.

Error 12: Sample Detect At Carousel Failed

- Meaning: B-ACS took a sample out of the magnet and tried to insert it into the magazine. The sample could not be detected in the magazine ring where it was inserted.
- Possible reasons:
- Someone has taken the sample out of the magazine before the sample changer completed its motion.
 - The reflex light fails to detect a sample at the magazine even if the position is occupied.
- Check the following:
- Does the sensor work (use the LED indicator at the sensor housing and at the connector panel of the new electronics)?
 - What is the range from where a sample is detected?
 - Use the diagnostic command **OM** to find the error (see section [6.8](#)).
- Technical background: The sensor signals SIGMA_INNER and SIGMA_OUTER are wired using connector #6 at the connector panel.

Error 13: Sample Detect At Magnet Failed

Meaning: B-ACS tried to take a sample out of the magnet. The sample could not be detected inside the magnet (if you have the new electronics with a sample down detection box installed) or could not be seen at the shim top light barrier even if the lift is on.

Possible reasons:

- Lift is weak, maybe main pressure supply is not constant.
- Upper shim light barrier is damaged.
- Sample down detection box not working properly.

Check the following:

- Insert / Eject samples using the manual lift button (or the diagnostic commands **LU** and **LD** - see section [6.8](#)).
- Watch the sensor LED's "SIGSH" (if you have the new electronics) and "Samp Down" (only if the sample down detection box is installed).
- Query B-ACS for the state of the upper shim light barrier using command **ST** and the diagnostic command **OS** (see chapter [6](#)).

If the sample down detection box is installed:

- Watch the indicator at the box. The indicator will only be lit if a sample is down in the magnet.
- Ask B-ACS for the state of the sample down sensor using the command **PD** (see section [6.7.1](#)).

Technical background: The sensor signal SIGSH is wired using connector #5 at the connector panel.

The sensor signal SAMPLE DOWN is wired using connector #8 at the connector panel.

Error 14: Sample Grasping Failed

- Meaning:** B-ACS tried to take a sample out of the magazine or magnet, but the sample is still detected at the lower sensor (at the magazine, at the shim top) after the vertical cylinder has reached its upper end position.
- Possible reasons:**
- Mis-adjusted / damaged sensor.
 - Sample is stuck in the magazine or in the BST.
 - Pincer did not close enough to create enough friction to grasp the sample.
- Check the following:**
- If the sample could not be taken from the magazine:

Possible reasons:

 - a) Someone has inserted a new sample into the magazine before the sample changer has completed its motion.
 - b) The reflex lights detect a sample at the magazine even if the position is empty.

Check the following issues:

 - a) Does the sensor work (use the LED indicator at the housing and at the connector panel of the new electronics)?
 - b) What is the range from where a sample is detected?
 - c) Use the diagnostic command **OM** to find the error (see section [6.8](#)).
 - If the sample could not be taken from the BST (magnet):

Possible reason:

The BST upper light barrier or the sample down detection box is damaged.

Check the following:

 - a) Insert / Eject samples using the manual lift button (or the diagnostic commands **LU** and **LD** - see section [6.8](#)).
 - b) Observe the “SIGSH” (if you have a new electronics) and “Samp Down” (only if the sample down detection box is installed) sensor LED’s.
 - c) Query B-ACS for the state of the upper shim light barrier using the commands **ST** and **OS** (see chapter [6](#)), and for the state of the sample down detection sensor using the command **PD** (see section [6.7.1](#)).

Use the diagnostic commands **IJ** and **EJ** to repeat the motions which caused the error (see chapter [6](#))!
- Technical background:** The sensor signal SIGSH is wired using connector #5 at the connector panel.
- The sensor signals SIGMA_INNER and SIGMA_OUTER are wired using connector #6 at the connector panel.
- The sensor signal SAMPLE DOWN is wired using connector #8 at the connector panel.

Error 15: Shim System Not Empty

Meaning:

- During initialization, B-ACS tried to move down to the BST to check if there is a sample hanging at the pincer, but the BST upper light barrier beam is already interrupted, or
- B-ACS tried to insert a sample into the magnet and there is already a sample inside the BST (BST upper light barrier is closed) or, if the sample down detection box is installed, it is detected down inside the magnet.

Possible reasons:

- There is really a sample down in the magnet.
- There is really a sample at the top of the BST interrupting the upper light barrier beam (e.g. lift was turned on manually using the BSMS keyboard and a sample was in the magnet and is now hovering in the air stream).
- The sample down detection box is not working correctly (if installed).
- The BST upper light barrier is damaged.

Check the following:

- Insert / Eject samples using the manual lift button (or the diagnostic commands **LU** and **LD** - see section [6.8](#)).
- Observe the sensor LED's "SIGSH" (if you have a new electronics) and "Samp Down" (only if the sample down detection box is installed).
- Query B-ACS for the state of the upper shim light barrier using the diagnostic commands **ST** and **OS** (see chapter [6](#)), and for the state of the sample down detection sensor using the command **PD** (see section [6.7.1](#)).
- If the sample down detection unit is installed, check if the jumper inside the unit is really set to B-ACS (it may be set to BSR).

Technical background:

The sensor signal SIGSH is wired using connector #5 at the connector panel.

The sensor signal SAMPLE DOWN is wired using connector #8 at the connector panel.

Error 16: Code Wheel Detection Failed! Code: xxx

Meaning: B-ACS read the code wheel and the value received was outside the range of 1 to 60. The value read will be displayed behind "CODE".

Possible reasons:

- Dust / dirt is on the code wheel.
- The code wheel unit is not synchronized with the magazine locked position.
- The code wheel detection lights are damaged.
- Is the magazine positioning switch working correctly (check POSIG LED at connector panel if you have new electronics)?
- The 16-pin flat ribbon cable to the code wheel unit is not connected or is connected incorrectly.

Check the following:

- Is the code wheel clean?
- Is the 16-pin flat ribbon cable connected to the code wheel unit? If the error occurred for the first time after a B-ACS modification, it can be assumed that the cable was inserted the wrong way. Reverse the cable (nothing will be damaged if the cable is reversed).
- Use the diagnostic command **CA** (see section **6.8** to find out if the code wheel unit is synchronized with the magazine lock (the position displayed should change in the middle between 2 locked magazine positions) and not located near the locked position.
- Does the magazine move to all positions using the arrow keys at the front panel left to the display (try forward and backward motions!)? Does it lock properly?

Technical background: If you have new sample changer electronics and the firmware version is before 20021112 Built 05, download the newest firmware version from the Bruker FTP server.

The sensor signal POSIG is wired using connector #4 at the connector panel.

Hint: Code wheel units are only exchanged as a complete package (electronics, belt & and code wheel itself). Never exchange the light emitting and light sensing board separately! They are precisely aligned with another!

Error 21: Codewheel Misadjusted For Position No: xxx

Meaning:	B-ACS read the code wheel and the value received was not the expected value, e.g., if B-ACS moves forward from position 18, the value read at the next locked magazine position must be 19. If it is not 19, this error is raised.
Possible reasons:	The same as at error 16 "CODEWHEEL DETECTION FAILED! CODE: xxx"
Check the following:	The same as at error 16 "CODEWHEEL DETECTION FAILED! CODE: xxx"
Technical background:	The same as at error 16 "CODEWHEEL DETECTION FAILED! CODE: xxx"

Error 22: No Free Magazine Position

Meaning:	The B-ACS was asked to eject a sample from the magnet and to place it back into the magazine, but all the positions are occupied.
Possible reasons:	<ul style="list-style-type: none">• Someone has manually filled all the magazine holder positions.• The reflex lights detect a sample at the magazine even if the position is empty.
Check the following:	<ul style="list-style-type: none">• Does the sensor work (use the LED indicator at the sensor housing and at the connector panel of the new electronics)?• What is the range from where a sample is detected?• Use the diagnostic command OM (see section 6.8) to find the error.
Technical background:	The sensor signals SIGMA_INNER and SIGMA_OUTER are wired using connector #6 at the connector panel.

Error 23: Sample Missing

- Meaning: The B-ACS was asked to take a sample from the magazine and to insert it into the magnet, but no sample is present at the specified position.
- Possible reasons:
- Someone has taken the sample out of the magazine before the sample changer has completed a motion sequence.
 - The reflex light is not detecting a sample at the magazine even when the position is occupied.
- Check the following:
- Does the sensor work (use the LED indicator at the housing and at the connector panel of the new electronics)?
 - What is the range from where a sample is detected?
 - Use the diagnostic command **OM** to find the error (see section [6.8](#)).
- Technical background: The sensor signals SIGMA_INNER and SIGMA_OUTER are wired using connector #6 at the connector panel.

Error 25: Failure Of Spinning Device

- Meaning: B-ACS tried to fix the position of the barcode collar using the small white wheels, but the corresponding pneumatic cylinder was not be detected in it's "fixed" position.
- Possible reasons:
- The 26 pin flat ribbon cable from the electronics barcode detection piggy-back board to the barcode reading device is not connected.
 - The detection micro-switches do not work (there is currently no indicator for this sensor).
 - The cylinder or valve does not work.
 - The pressure reduction throttle is misadjusted.
- Check the following:
- Does the barcode collar fixing cylinder work with the manual control button?
 - Does the sensor work (can you hear it clicking)?
 - Use the diagnostic command **BT** to find the error.

Error 26: Arm Positioning Failed

Meaning: B-ACS tried to move the vertical cylinder over the outer magazine ring but could not lock at this position after 3 attempts. This error will only occur if you have a B-ACS with 120 holder positions.

Possible reasons:

- The speed of the horizontal cylinder is too fast.
- The reflex light barrier above the outer magazine ring is improperly adjusted / damaged / dirty.

Check the following:

- Switch the B-ACS to manual operation mode.

Move the horizontal cylinder by hand slowly from the inner magazine ring to the magnet and check if the signals follow those in the **Table 7.1** below.

- Check movement to the A2 position using the diagnostic command **A2** - see section **6.8** (the A2 position is above the outer magazine ring with holders 61-120).

Check if the short circuit valve is being activated when the horizontal arm is above the outer magazine ring.

Start the motion from the inner ring and from the shim system to see if both directions work. Use the diagnostic commands (see section **6.8**) **A1** to move to the inner magazine ring and **AS** to move to the shim system.

Technical background: The signals MAG and SHIM are wired using connector #2 at the connector panel.
The signal SIGHO_INNER and SIGHO_OUTER are wired using connector #3 at the connector panel.

Table 7.1. **Sensor Signal Table**

MAG	SIGHO INNER	SIGHO OUTER	SHIM	Meaning
On	On	Off	Off	The horizontal arm is above the inner magazine ring.
Off	On	Off	Off	The horizontal arm is near the outer magazine ring, but closer to the inner magazine ring. Sample cannot be gripped from the outer magazine ring.
Off	On	On	Off	The horizontal arm is directly above the outer magazine ring and is able to grip samples from there.
Off	Off	On	Off	The horizontal arm is near the outer magazine ring, but not above it. It is a little too far outside in the direction of the magnet
Off	Off	Off	Off	The horizontal arm is somewhere between the outer magazine ring and the magnet.
Off	Off	Off	On	The horizontal arm is directly above the magnet.

Error 50: Barcode Reader Not Present

- Meaning: B-ACS was asked to read a barcode or to transmit some barcode information for a specified position, but there is no barcode reader installed.
- Possible reasons:
- There is no barcode reader installed.
 - The barcode reader was not detected by the B-ACS main control board.
 - There is no Board Information System (BIS) present on the barcode board.
- Check the following:
- Check if you have mounted the barcode reader piggyback board correctly in the main control board socket.
 - Reset B-ACS and wait until the initialization is complete. Then try again. If it does still not work, please contact the Bruker Help desk

Error 51: Invalid Command

Meaning: The command sent to B-ACS is unknown or invalid.

Possible Reasons and What to Check:

- The command is not valid. Check if the command is available in the **"Software Commands"**.
- Unknown command for your software version. During the development progress new commands are continuously being added to the B-ACS firmware. With an older firmware version, not all of the commands may be present.
- When you have the old electronics use only capital letters when entering commands. Only the new B-ACS electronics can utilize commands regardless of case sensitivity.
- When you have the old electronics use exactly 1 space between a command and a parameter (if required). The new electronics (only) will except 0, 1, or 2 spaces between the command and the parameter.
- There were already some characters in the command receive buffer before the current command was received. The command you sent was added to the end of these characters and was interpreted as an invalid command. Reenter the command.

If you have new electronics, also check the following:

If the error occurred during automation and the command send was a valid command, check the following: If the B-ACS firmware version is before 20040526 Built 16, please download the newest firmware version from Bruker FTP server.

Technical background: Old B-ACS firmware versions monitored the main air pressure continuously, even if there was no motion executed which needed the air pressure. If the air pressure fell below 3 bar, the error 01: INSUFFICIENT AIR PRESSURE was created and transmitted to ICONNMR. ICONNMR did not clear (and not recognize!) this error message before it sent the next command. The next command was a normal operation command and not allowed in B-ACS error mode, thus the error message was not cleared and was still visible on the B-ACS display.

Error 52: Invalid Parameter

Meaning: The parameter transmitted after the command was outside the expected range.

Possible Reasons and What to Check:

- The parameter is outside the range (e.g. you want to insert a sample from position 65, but you only have a B-ACS 60). Check the range using the **"Software Commands"**.
- When you have older electronics use exactly 1 space (blank) between a command and a parameter. The new electronics can work with 0, 1, or 2 spaces between the command and the parameter, too.
- Do not enter any spaces (blanks) between the parameter and the ENTER key.

Error 54: Horizontal Optic Not Present

Meaning: The horizontal optic which detects the horizontal position above the outer magazine ring is not present.

Possible reasons: You have entered the diagnostic command **"OH"** (see section **6.8**) to adjust the horizontal optic, but B-ACS assumes that it has only 60 holders, and that the optic does not exist.

Check the following:

- Does the B-ACS really have 120 holder positions (2 magazine rings)? Is the horizontal optic physically installed?
- Is the sensor cable from the horizontal optic connected to connector #3 at the connector panel?
- Do the sensor signals follow those in the **Table 7.1**?

Error 55: Autoprep Hardware Not Present

Meaning: B-ACS is not connected to an ASP (Automated Sample Preparation) station, so some commands are not enabled.

Possible reasons: You have tried to send the command **XL** (see chapter **6**) to mark a sample as "measured". This command is disabled without the ASP station.

Check the following:

- Do you really have an ASP station connected to B-ACS?
- If it still does not work, please contact the Bruker Help desk.

Error 57: xx Command Is Not Available In Diagnostics!

Direct Lift Control Is Switched Off! Where xx is I2, IJ, E1, EJ, SE, TL, LD, or LU.

Meaning: The diagnostic command (see section **6.8**) you have entered cannot be executed because the BST sample lift is required for the execution. The BSMS is currently controlling the sample lift, rather than B-ACS.

Solution: Change the sample lift control back to B-ACS using the command **NL** (see chapter **6**) and retry the command which caused the error.

Error 59: Busy

Meaning: B-ACS is currently unable to execute the command.

Possible reasons:

- A command that was previously entered is not completed -> B-ACS is still executing this command.
- B-ACS is in error mode. Only a few commands are enabled in error mode (see section **6.7.2**).
- B-ACS is blocked by the ASP station and is not allowed to move and to change the magazine position.

All the errors with error number 80 and higher are sensor errors and were implemented in the new B-ACS electronics firmware version 20031020 Built 13. These errors indicate that a physically impossible combination of sensor signals has been detected by the B-ACS electronics.

Error 80.x

Meaning: This error regards sensor errors at the horizontal cylinder. An illegal combination of the signals MAG, SHIM, SIGHO_INNER and SIGHO_OUTER has been detected.

Check the following: Please check if the sensor signals follow those in the **Table 7.1**. (B-ACS 120 only).

For B-ACS 60, only the MAG and SHIM signals must correspond to the sensor signal table. The SIGHO_INNER and SIGHO_OUTER must be off.

Technical background: The signals MAG and SHIM are wired using connector #2 at the connector panel.

The signal SIGHO_INNER and SIGHO_OUTER are wired using connector #3 at the connector panel.

Error 80.1: Sensor Error: Horizontal Cylinder. Magazine & Shim!

Meaning: The horizontal end position switch above the magnet (SHIM) and above the inner magazine ring (MAG) are both active.

Error 80.2: Sensor Error: Horizontal Cylinder. Magazine & Not A2 Inner!

Meaning: You have a B-ACS with 120 holder positions and the horizontal arm is detected above the inner magazine ring (MAG sensor is active), but the horizontal sensor SIGHO_INNER is not active (but should be).

Error 80.3: Sensor Error: Horizontal Cylinder. Magazine & A2 Outer!

Meaning: You have a B-ACS with 120 holder positions and the horizontal arm is detected above the inner magazine ring (MAG sensor is active), but the horizontal sensor SIGHO_OUTER is active (but should be inactive).

Error 80.4: Sensor Error: Horizontal Cylinder. Shim & A2 Inner!

Meaning: You have a B-ACS with 120 holder positions and the horizontal arm is detected above the shim system (SHIM sensor is active), but the horizontal sensor SIGHO_INNER is active (but should be inactive).

Error 80.5: Sensor Error: Horizontal Cylinder. Shim & A2 Outer!

Meaning: You have a B-ACS with 120 holder positions and the horizontal arm is detected above the shim system (SHIM sensor is active), but the horizontal sensor SIGHO_OUTER is active (but should be inactive).

Error 81: Sensor Error: Vertical Cylinder. Up & Down!

Meaning: The vertical cylinder end position detection mechanism detects the vertical cylinder at both end positions simultaneously.

Check the following: Check the sensor signals UP & DOWN by using manual motion of the vertical cylinder. The signals UP and DOWN are wired using connector #1 at the connector panel.

Error 82.x:

Meaning: This error pertains to sensor errors inside the BST. Either an illegal combination of the signals SIGSH and SAMPLE DOWN has been detected, or the BST shim top light barrier (SIGSH) is closed, even when the lift (controlled by B-ACS) is not turned on.

Check the following:

- Insert / Eject samples using the manual lift button (or the diagnostic commands **LU** and **LD** - see section [6.8](#)).
- Observe the sensor LED's "SIGSH" (if you have new electronics) and "Samp Down" (only if the sample down detection box is installed).
- Query B-ACS for the state of the upper shim light barrier using the diagnostic commands **ST** and **OS** (see section [6.8](#)).

If the sample down detection box is installed:

- Observe the indicator at the box. It will only be lit if a sample is in the magnet.
- Query B-ACS for the state of the sample down sensor using the command **PD** (see section [6.7.1](#)).

Technical background: The sensor signal SIGSH is wired using connector #5 at the connector panel.
The sensor signal SAMPLE DOWN is wired using connector #8 at the connector panel.

Error 82.1: Sensor Error: Sample At Magnet. Lish & Sample Down!

Meaning: The sensor signal SIGSH (at the BST shim top) and SAMPLE DOWN (in the sample inside the BST) are simultaneously active.

Error 82.2: Sensor Error: Sample At Magnet. Lish Is Closed!

Meaning: The sensor signal SIGSH (at the BST shim top) detects a sample, although the lift (controlled by B-ACS) is not turned on.

Possible reasons:

- The lift does not stop even though B-ACS closes the lift valve (e.g. the BSMS unintentionally controls the lift).
- The sample does not drop down into the BST and is stuck at the shim top light barrier.
- The BST shim top light barrier is damaged.

Error 82.3: Sensor Error: Sample At Magnet. Sample Is Down!

Meaning: A sample is still detected down in the magnet after a sample was supposed to be removed from the magnet by the B-ACS pincer (normal eject-procedure), and the lift was turned off.

Possible reasons:

- The pincer did not grasp the sample correctly, but rather pushed it down into the BST so that the BST upper light barrier is open (the sensor no longer sees a sample). After turning off the lift, this sample will fall back into the BST.
- The sample down detection box does not work.

Error 83: Sensor Error: Sample At Magazine!

- Meaning: This error pertains to sensor errors at the magazine light barrier. This error can only occur if you have a B-ACS with 120 holder positions. When inserting/removing a sample from the magazine ring with the B-ACS pincer (normal insert or eject procedure), the magazine light barrier signal from the magazine's other ring (where no sample is inserted or ejected) also changes.
- Possible reasons:
- Someone has taken the sample out of the magazine before the sample changer has completed its motion sequence.
 - Someone has inserted or removed a sample manually from the magazine ring (regardless of the position) while B-ACS is inserting or removing a sample from the magazine ring.
 - The reflex light did not detect a sample at the magazine even when the position was occupied.
 - The reflex light detects a sample even when the position is empty.
- Check the following:
- Does the sensor work (use the LED indicator at the connector panel housing of the new electronics) ?
 - What is the range from where a sample is detected?
 - Use the diagnostic command **OM** to find the error (see section [6.8](#)).
- Technical background: The sensor signals SIGMA_INNER and SIGMA_OUTER are wired using connector #6 at the connector panel.

No or Very Slow Initialization Process

(starts a few minutes after reset)

Meaning: B-ACS does not do anything after a reset, whereas after a few minutes the text "SAMPLECHANGER INITIALIZATION" is displayed and B-ACS starts to initialize with very long interrupts between the individual motions.

Possible reasons: The Debug Baud rate hex switch at the board is set to the wrong value. Check them. See **"Main Control Board Hex Switches" on page 122.**

After a Short Mounting Time at the NMR Magnet, B-ACS no Longer Works

(no motion visible, seems to be dead).

Possible reasons: The earlier new generation B-ACS electronic main control boards (ECL00 & ECL01) contained DC/DC converters which sometimes do not work in strong magnetic stray fields (magnets $\geq 400\text{MHz}$ without UltraShield). If customers complain about this problem, the B-ACS electronics must be upgraded to at least ECL02 at no cost.

There is a Spike in the Spectrum Which Cannot be Seen When B-ACS is Turned Off.

Meaning: With the new electronics some customers have complained about a spike being present in the NMR spectrum.

Check the following: Check if the electronics have firmware version before 20030422 Built 08.

Solution: Download the latest firmware version from the Bruker FTP server.

Firmware versions greater or equal to 20030422B08 allow the micro controller sleep until it is required.

Magazine starts motion, but does not stop.

- Possible reasons:
- The magazine positioning switch (POSIG) is damaged.
 - The start motor signal is always active
- Check the following:
- Does the positioning sensor (POSIG) work? (can you hear it clicking?) with new electronics only: look at the POSIG sensor LED.
 - Is the sensor physically pushed and released during magazine motion? Check the adjustment.
- Technical background: The sensor signal POSIG is wired using connector #4 at the connector panel. The signals to start the motor and to set up the direction are in the 26pin flat ribbon cable to the power supply box.

Barcode Reader needs a lot of attempts to read the code (standard barcode reader AND new vertical barcode reader) / does not read the barcode or the new vertical barcode reader often moves magazine during barcode reading).

- Meaning: The barcode reader is not aligned correctly.
- Possible Reasons and Solutions:
- If you have a standard barcode reader (with rotating barcode collar) try to adjust detecting distance and height.
 - Does the motor rotate the barcode collar?

Check if the barcode collars are not held with too much pressure. The collars must revolve continuously without any skipping.
 - If you have a new vertical barcode reader, be sure that it does not look straight to the middle of the collar. Rotate it a little bit inside of the mounting holes.

Be sure that the collar detecting reflex light barriers are adjusted correctly. If there is a barcode collar at the sample, the orange LED must be lit. If there is no barcode collar at the sample (only naked glass tube or no glass tube), the orange LED at the sensor must be off! The green LED (good operation mode) must be lit in both states, otherwise the threshold is set wrong. Try to readjust the threshold by teaching both situations to the sensor. Refer to the corresponding installation manual.
- Both barcode reader types:
- Look at the barcode collar. Is it damaged? Is the tape (only at standard rotating barcode collars) still tight? Are the lines and white areas of the barcode ok? Are lines / white areas missing / dirty?

After taking a sample out of the magnet or magazine, the vertical arm moves up, the pincer opens (and lets the sample fall down) and then it moves down to grasp it again.

Possible Reasons and Solutions: The light barrier at the magazine (resp. at the magnet) does still detect a sample, so B-ACS assumes that it could not grasp the sample out of the magazine (the magnet) and retries.

Check the following:

- Does the sensor work (use LED indicator at the housing and at the connector panel of the new electronics)?
- How far is the range where a sample is detected?
- Use the diagnostic command **OM** (see section [6.8](#)) to find the error.

Technical background: The sensor signals SIGMA_INNER and SIGMA_OUTER are wired using connector #6 at the connector panel.

The sensor signal SIGSH is wired using connector #5.

Special Tools

8

Special Tools for B-ACS

8.1

Table 8.1. Tools for mounting the Automatic Sample Changer

Part Number	Part Name
14667	Open End Wrench 13/17
14478	Allen Key Wrench 1.5 mm CU-BE
10500	Allen Key Wrench Set (with 1.5, 2, 2.5, 3, 4, 5, 6, 8, and 10 mm wrenches)
17744	Allen Key Wrench with handle 5 mm
H5042	B-ACS Grease-Box for Vertical Assembly (light-brown color)
H5043	B-ACS Grease-Box for Horizontal Assembly (clear-white color)

Operator Maintenance

9

Greasing the Horizontal Arm

9.1

The horizontal arm should be lubricated bi-annually (at least) with B-ACS grease P/N H5043 (has a clear-white color) to allow for smooth operation.

Greasing the Vertical Cylinder

9.2

The moving parts of the vertical cylinder should be lubricated bi-annually (at least) with B-ACS grease P/N H5042 (has a light brown color) to allow for smooth up and down movement.

Arm Adjustment

9.3

The arm should be adjusted initially, and rechecked periodically to ensure that the samples are being properly grasped by the pincher. Refer to chapter 4, "**Settings and Adjustments**".

Cabinet Adjustment

9.4

The cabinet will need adjusting if the sample, when approaching the magazine belt, is not centered perfectly in the sample holder of the magazine belt. If the inward position of the vertical cylinder is not correct, then refer to the chapter 4, "**Settings and Adjustments**". If the spinner tip edge gets too close to the sample holder (less than 5 mm) move the cabinet downwards on the column (refer to chapter 4, "**Settings and Adjustments**"). The correct distance between the spinner top edge and the magazine belt should be approximately 5 mm.

Vertical Cylinder

9.5

The vertical position of the vertical cylinder is factory set and does not need adjusting. The horizontal position can be adjusted by loosening the two screws under the bottom support bracket of the vertical cylinder (refer to chapter 4, "**Settings and Adjustments**").

Magazine Belt Tension Adjustment

9.6

The adjustment mechanism under the right carousel wheel serves for setting the tension of the magazine belt. The tension should be increased only when the belt filled with samples hangs more than 5 to 8 mm under the wheel line on the strip between the two wheels. Excessive tension will damage belt and wheel bearings.

Pneumatic Cylinder Setting

9.7

The speed of both vertical and horizontal cylinder can be varied by regulating the outlet air flows of the cylinder supply connections. Refer to chapter 4, section 4, "***Pneumatic Cylinder Settings***" for details.

Cleaning the Inside of the Vertical Cylinder

9.8

When an „Upward Motion Failed“ or „Downward Motion Failed“ error message occurs, it may be necessary to clean the inside of the Vertical Cylinder. This is accomplished by: turning the sample changer off, disconnecting the sensor and hydraulic lines to the vertical cylinder, marking the current position of the cylinder with i.e. a pencil, removing the four screws and cover plate located just above the pincher, and sliding the cylinder out. To clean, wipe the inside of the cylinder with a clean cloth and alcohol. Apply vertical grease P/N H5042 (light brown color) to the cylinder and replace the cylinder, cover and screws and return the cylinder to its original position (that you marked earlier) before tightening. Once you have tightened the screws plug in the sensor and hydraulic lines (for the vertical cylinder) and turn on the sample changer.

Cleaning the Magazine Light Barrier

9.9

Once a year the magazine light barrier should be cleaned with warm water and a damp lint-free cotton cloth or towel.

Technical Data

10

Equipment Identification

10.1

Table 10.1. B-ACS Equipment Identification

Part Number	Description	Part Number	Description
H1080	B-ACS 60 Sample Changer	H800	B-ACS 120 Sample Changer
H91080	B-ACS 60/300 Sample Changer	H13800	B-ACS 120/300 Sample Changer
H131080	B-ACS 60/300 Sample Changer SAG Anti-vibration	H15800	B-ACS 120/300 Sample Changer SAG Anti-vibration
H9874	B-ACS 60 Sample Changer 400US+	H9877	B-ACS 120 Sample Changer 400US+
H141080	B-ACS 60/400 Sample Changer SAG Anti-vibration	H16800	B-ACS 120/400 Sample Changer SAG Anti-vibration
H9875	B-ACS 60 Sample Changer 500US+	H9878	B-ACS 120 Sample Changer 500US+
H41080	B-ACS 60/500 Sample Changer SAG	H6800	B-ACS 120/500 Sample Changer SAG
H31080	B-ACS 60/500 Sample Changer Magnex	H3800	B-ACS 120/500 Sample Changer Magnex
H9876	B-ACS 60 Sample Changer 600US+	H9879	B-ACS 120 Sample Changer 600US+
H11080	B-ACS 60/600 Sample Changer OXF	H1800	B-ACS 120/600 Sample Changer
H21080	B-ACS 60/600 Sample Changer Magnex	H8800	B-ACS 120/600 Sample Changer Magnex
H5895	B-ACS 60/600 Sample Changer SAG	H4800	B-ACS 120/600 Sample Changer SAG
H51080	B-ACS 60/700 Sample Changer SAG	H9800	B-ACS 120/700 Sample Changer SAG
H101080	B-ACS 60/750-800SB Sample Changer BAM		
H111080	B-ACS 60/800US2 Sample Changer BAM		
H151080	B-ACS 60/800 Sample Changer Magnex		
H61080	B-ACS 60 Sample Changer SAG D330	H10800	B-ACS 120 Sample Changer SAG D330
H71080	B-ACS 60 Sample Changer SAG D340	H11800	B-ACS 120 Sample Changer SAG D340
H81080	B-ACS 60 Sample Changer SAG D350	H12800	B-ACS 120 Sample Changer SAG D350
H121080	B-ACS 60/D360 Sample Changer WB	H14800	B-ACS 120/D360 Sample Changer WB

Technical Data

Power Supply Requirements

10.2

110/230V ~, 50/60 Hz

Current carrying capacity: 0.5 A

Fuse Protection

10.3

2 x 0.4 AT (slow blow fuse) at the Mains plug.

2 x 1.25 AT or 1 x 2.5 AT (slow blow fuse, inside the B-ACS housing at the power supply unit, depending on the power supply unit you have).

Air Requirements

10.4

3.5-4.5 bar (50-64 psi)

The air source must be **clean, dry and oil-free**.

Alternatively, nitrogen may be used.

Circuit Diagrams

11

List of B-ACS Circuit Diagrams

11.1

"Circuit Block Diagram"

"Internal Connections Diagram"

"CPU Board Diagram H25"

"CPU Board Diagram H10022"

"LC Display Board H178"

"Mounting the Light Barrier Cabinet on the Cabinet Assembly"

"Rear Side of the Light Barrier Cabinet"

"Location of the Position Switch on the Light Barrier Cabinet"

"Light Barrier Magazine Optic"

"Light Barrier at the Magazine"

"Connections for Operation"

"Power Supply Box Wiring Diagram"

Circuit Diagrams

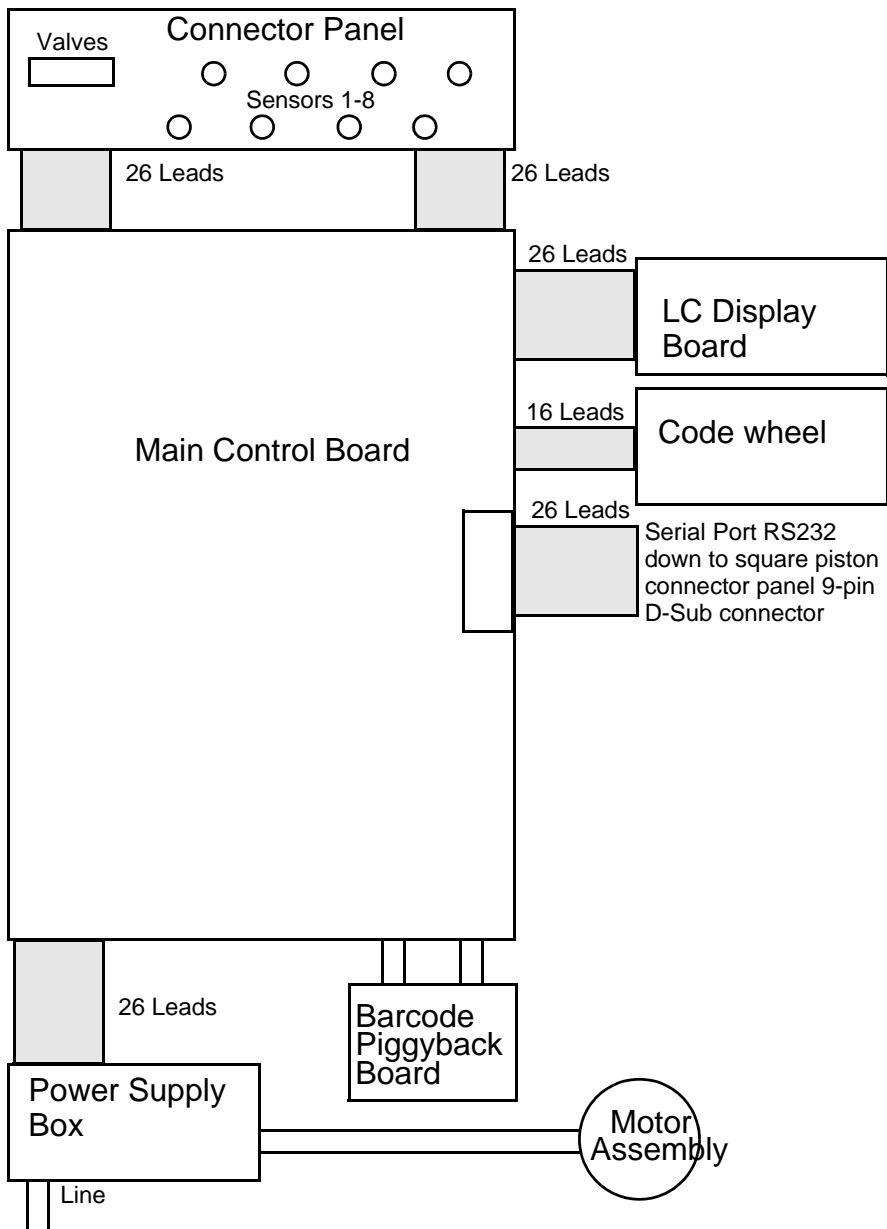

Figure 11.1. Circuit Block Diagram

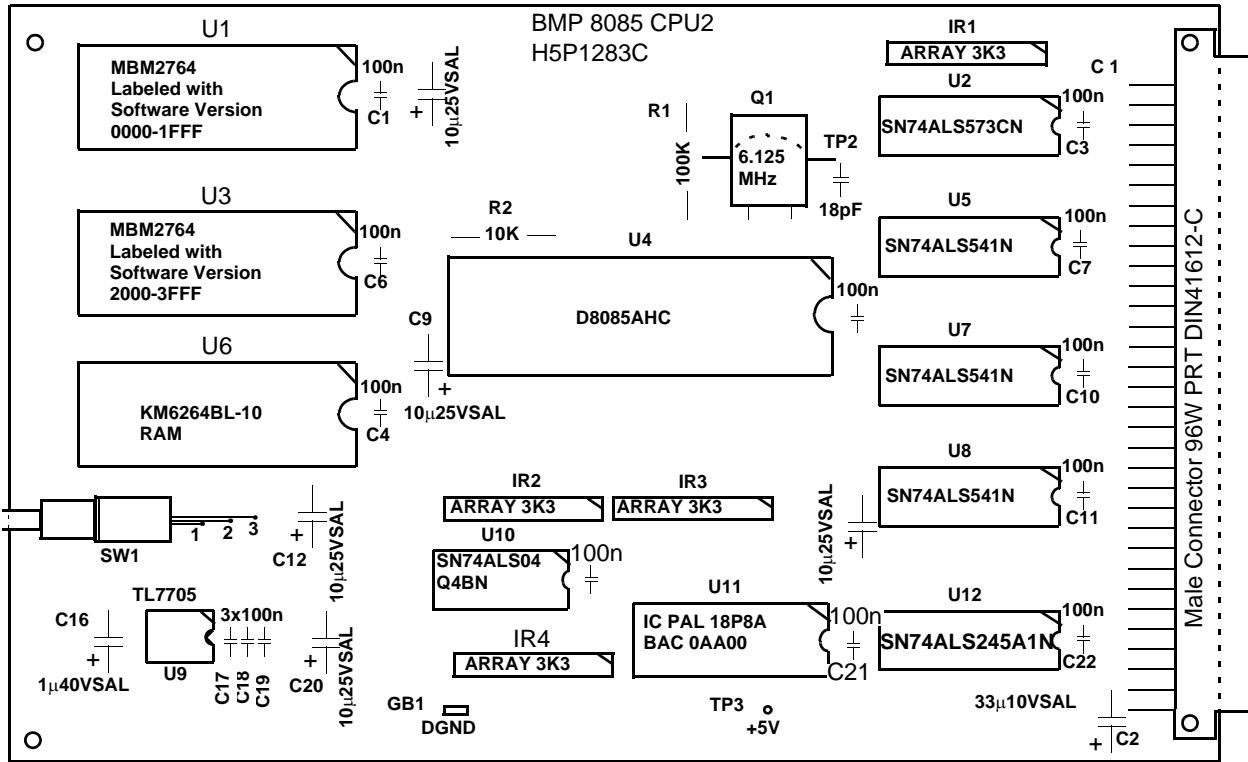

Figure 11.3. CPU Board Diagram H25

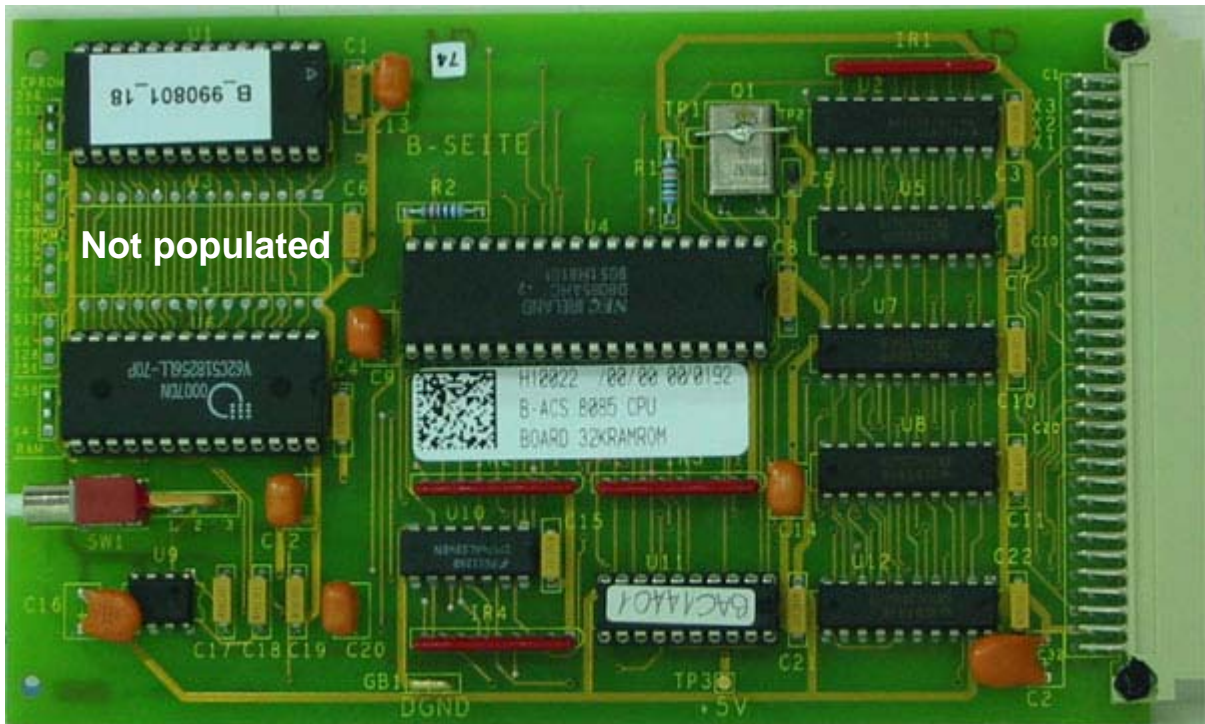

Figure 11.4. CPU Board Diagram H10022

B-ACS Interface Board Diagram

11.3

LC-Display Board

11.3.1

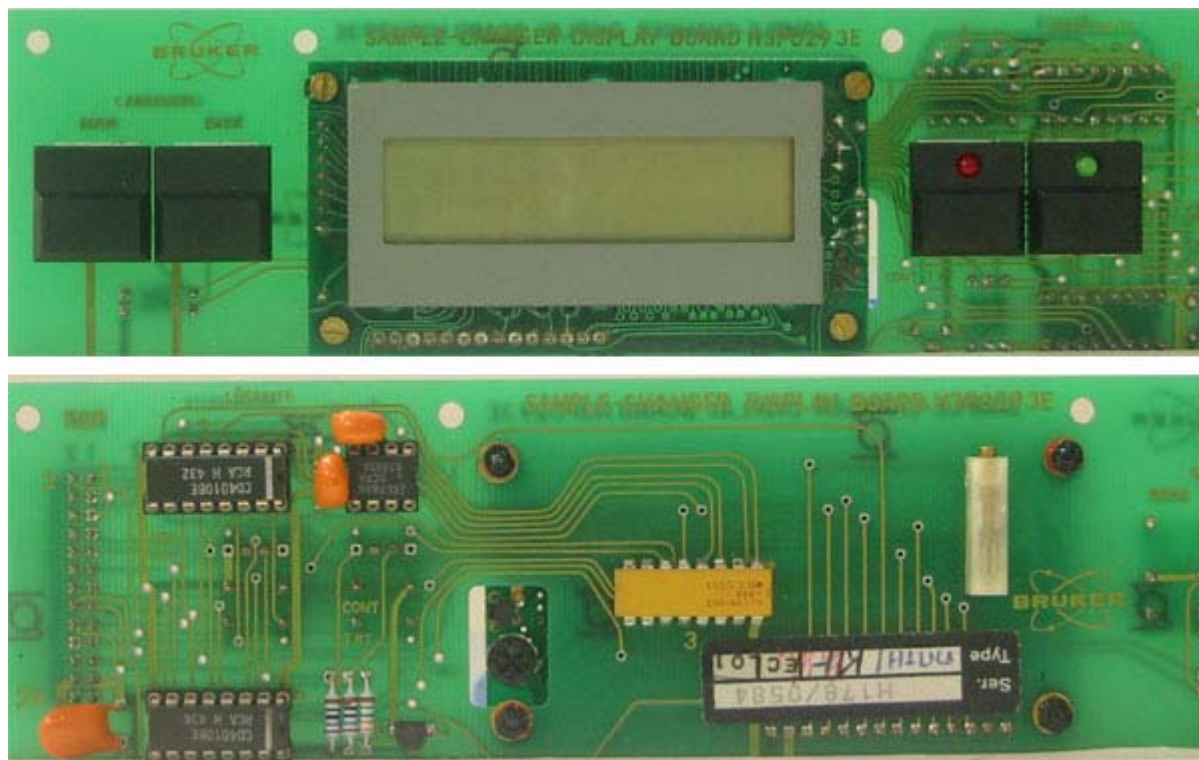

Figure 11.5. LC Display Board H178

Mounting the Light Barrier Cabinet on the Magazine

11.3.2

Mounting Instructions

Remove the rear panel of the cabinet assembly. Remove the rear panel of the light barrier cabinet. Fasten the light barrier cabinet onto the top of the Magazine Cabinet Assembly.

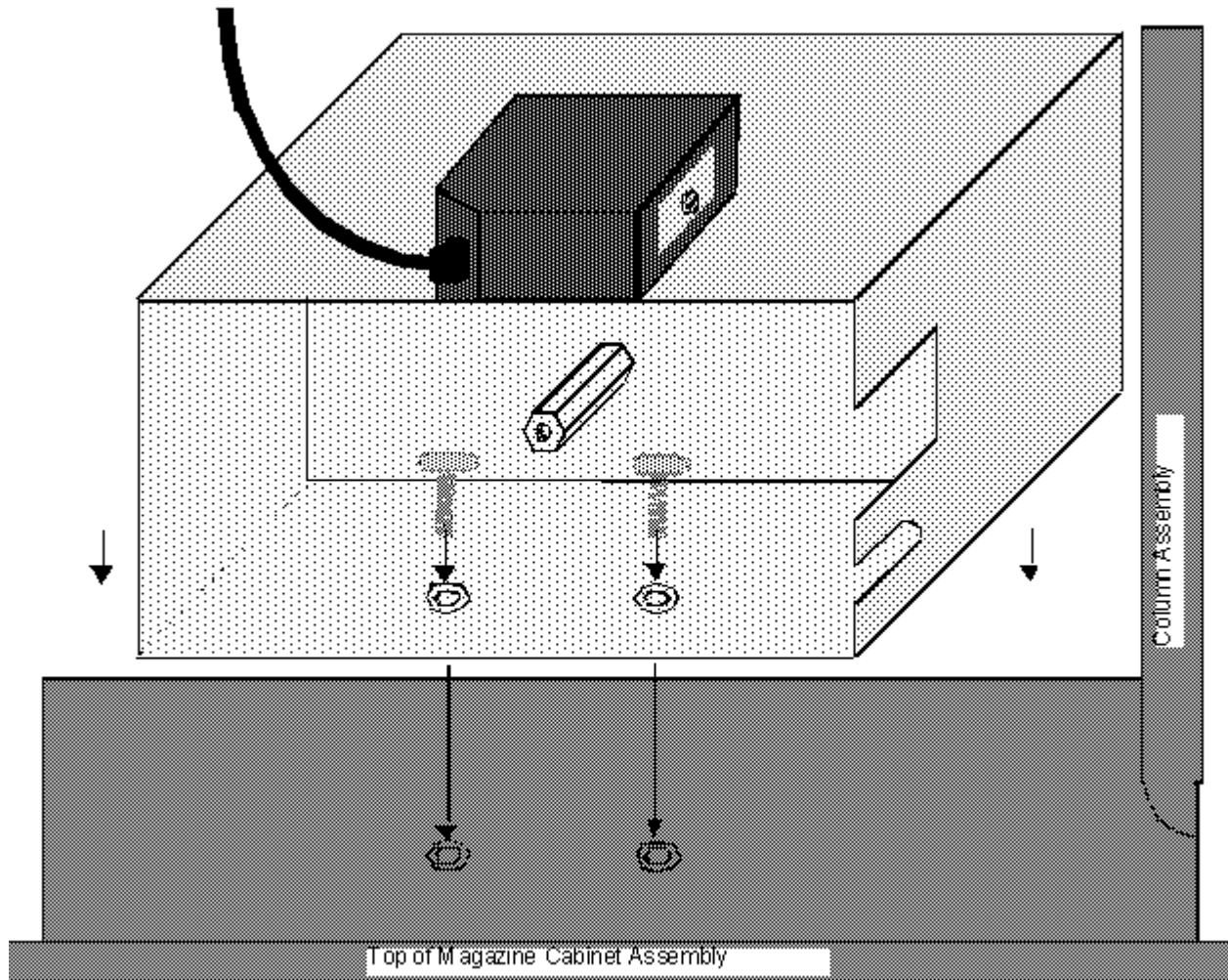

Figure 11.6. Mounting the Light Barrier Cabinet on the Cabinet Assembly

Place the position switch cables through the opening at the top of the cabinet as illustrated in **Figure 3.6**. Connect the two cables (No. 4 and No. 6) to the Sensor Connector Board as follows:

Position Switch (cable 4)	Plug No. 4	POSIG
Light Barrier at Magazine (cable 6)	Plug No. 6	LIGHT BARR MAGAZINE

On the back of the light barrier cabinet there are two plug connections, the top one is for the B-ACS 60 light barrier optic cable and the bottom one is for the B-ACS 120 light barrier optic cable.

When you are using a B-ACS 120 you must install a second light barrier optic at a right angle to the first as illustrated in. The B-ACS 120 optic is secured with a screw on top of the light barrier cabinet. Plug the cable from the B-ACS 120 light barrier optic into the bottom plug connector at the back of the light barrier case.

Three optic sensors within the optics, indicate whether the inside (M60) or outside (M120) position of the magazine belt is occupied.

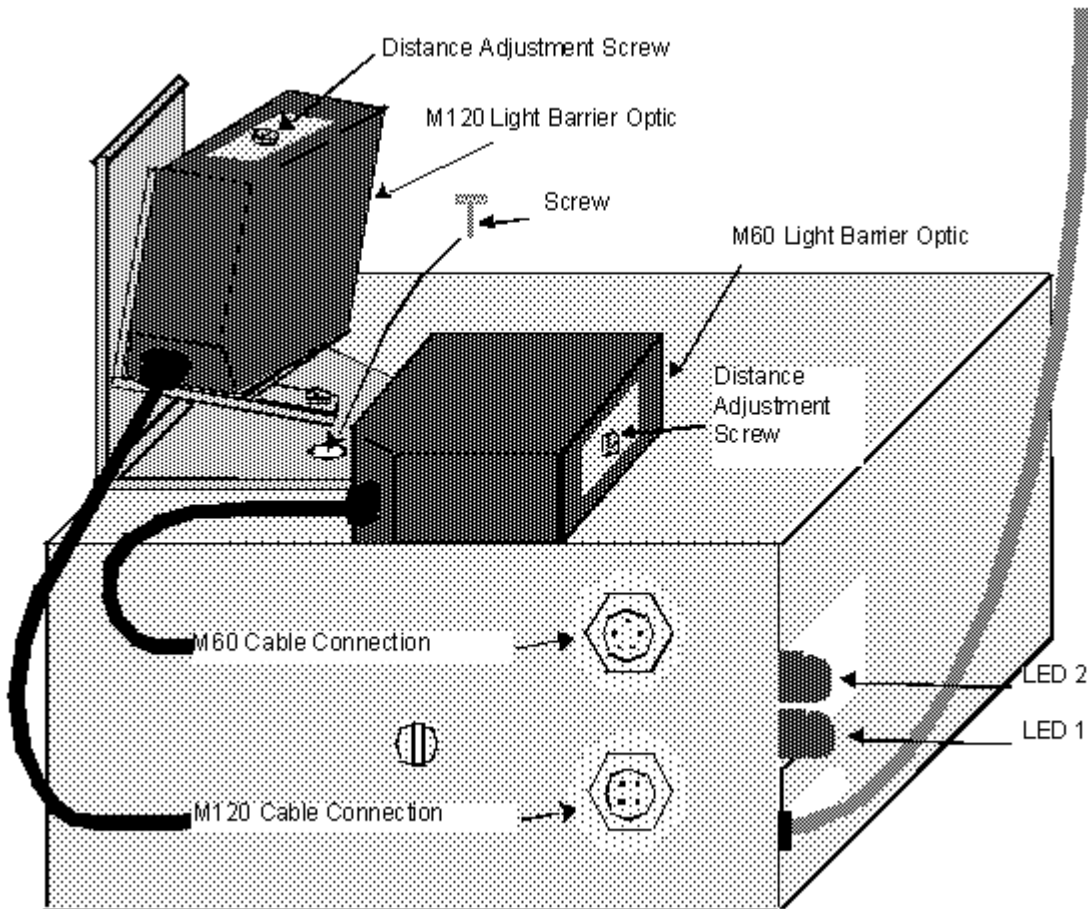

Figure 11.7. Rear Side of the Light Barrier Cabinet

Adjusting the Light Barrier Cabinet and Optics

11.3.3

Position Switch

The position of a sample on the magazine belt is adjusted with the position switch located at the bottom of the Optic. This adjustment will ensure that the pneumatic arm reaches the exact position repeatedly when the magazine belt moves forwards or backwards.

To make the adjustment turn the screw at the bottom of the switch until the pincher on the pneumatic arm is in the middle of the sample position on the magazine belt.

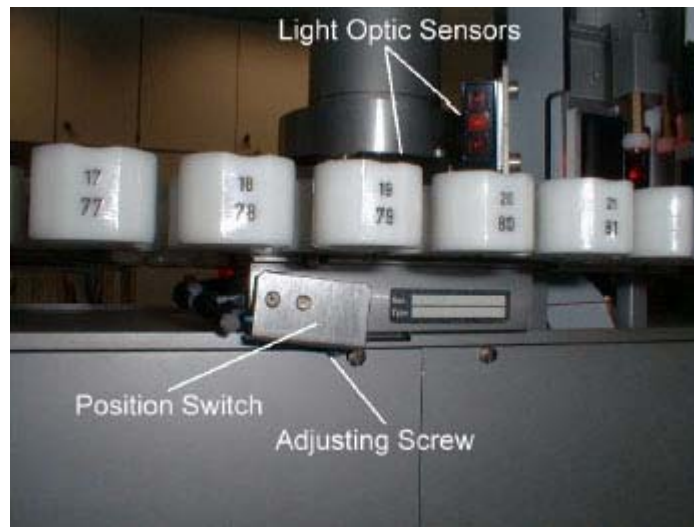

Figure 11.8. Location of the Position Switch on the Light Barrier Cabinet

Adjusting the M60 Light Barrier Optic

The adjustment of the reflex key for the detection of a sample at the inside position of the magazine belt is made through a distance adjustment screw on the side of the sensor optic. The range of the optics view should be between the middle and the outside of the magazine belt position.

You must ensure that the M60 optic detects a sample only in the inside magazine belt position, not the outside position, and likewise that the M120 optic detects a sample only in the outside position, not the inside.

The Light Barrier Magazine Board is located on the rear side of the rear panel of the light barrier cabinet. The M60 Optic cable ([Figure 11.6.](#)) is connected to this board through the upper connector on the rear panel of the light barrier cabinet.

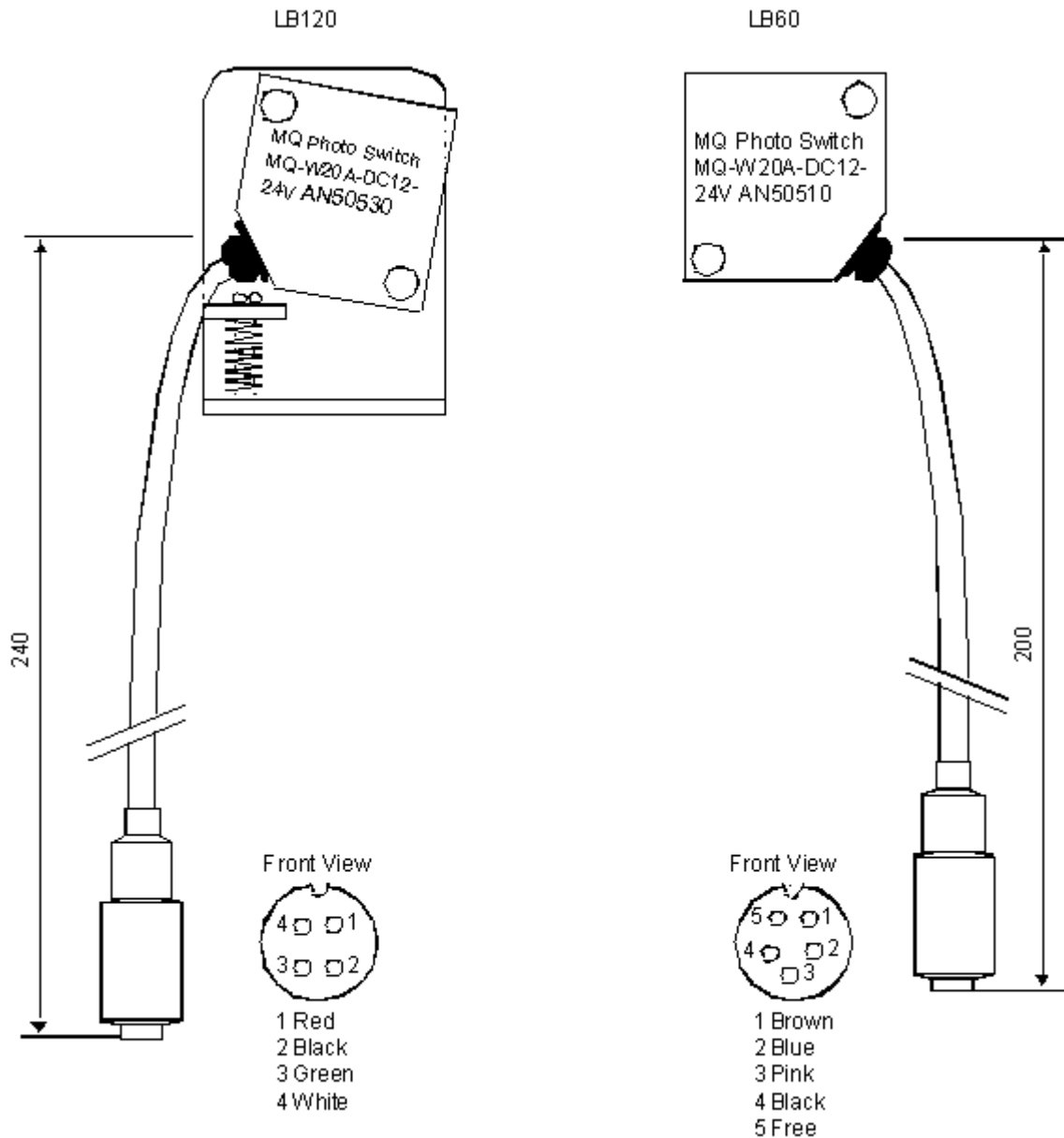

Figure 11.9. Light Barrier Magazine Optic

Adjusting the M120 Optic

The adjustment of the reflex key for the detection of a sample in the outside position of the magazine belt is made through a distance adjustment screw on the side of the sensor optic. With this adjustment you must reach two objectives:

1. The detection of a sample in the outside magazine position.
2. A negative detection of a sample in the inside magazine position, that is, the optic must not read the inside position on the magazine, only the outside.

With the adjustment of the distance, an increase in the aperture of the background for reflected surfaces is reached. The range of the optics view should be between the middle and the outside of the magazine belt position.

The M120 optic is connected to the lower connection (4 Pol.) on the back of the light barrier cabinet.

Mechanical Adjustment Procedures

1. Adjustment of the angle of inclination (tilt):

The magazine belt position should be unoccupied.

The distance adjustment screw is set on maximum „FAR“.

With a reflective background a reduction of the distance adjustment is possible. The distance adjustment screw is turned counter clockwise to „NEAR“ until the display „OPE“ is no longer activated (this provide an increase in the aperture of the background).

The optic is first adjusted as far as possible to the bottom, until the magazine belt is detected, then turned back gradually until the belt can no longer be detected.

You must ensure that the M120 optic detects a sample only in the outside magazine belt position, not the inside position.

2. Adjustment of the distance:

The magazine belt position should be occupied.

The distance adjustment screw is set on minimum „NEAR“.

Turn the distance adjustment screw clockwise to „FAR“ until the display is activated.



Note: Excessive dust or dirt at the lens surface of the optics reduces the optics recognition performance. Keep these surfaces clean.

Adjustment Instructions for the B-ACS Magazine Light Barrier

11.3.4

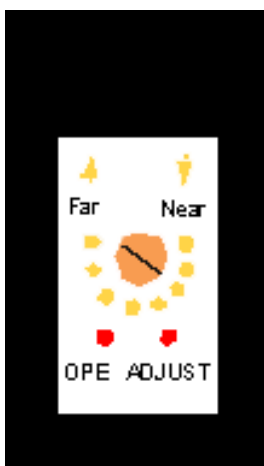

Default Adjustment for New Devices

Inner light barrier: Adjustment at about the 6-7 o'clock position (arrow points down slightly to the left).

Outer light barrier: Distance exactly to the middle between „Near“ & „Far“, and then one measure point to „Near“.

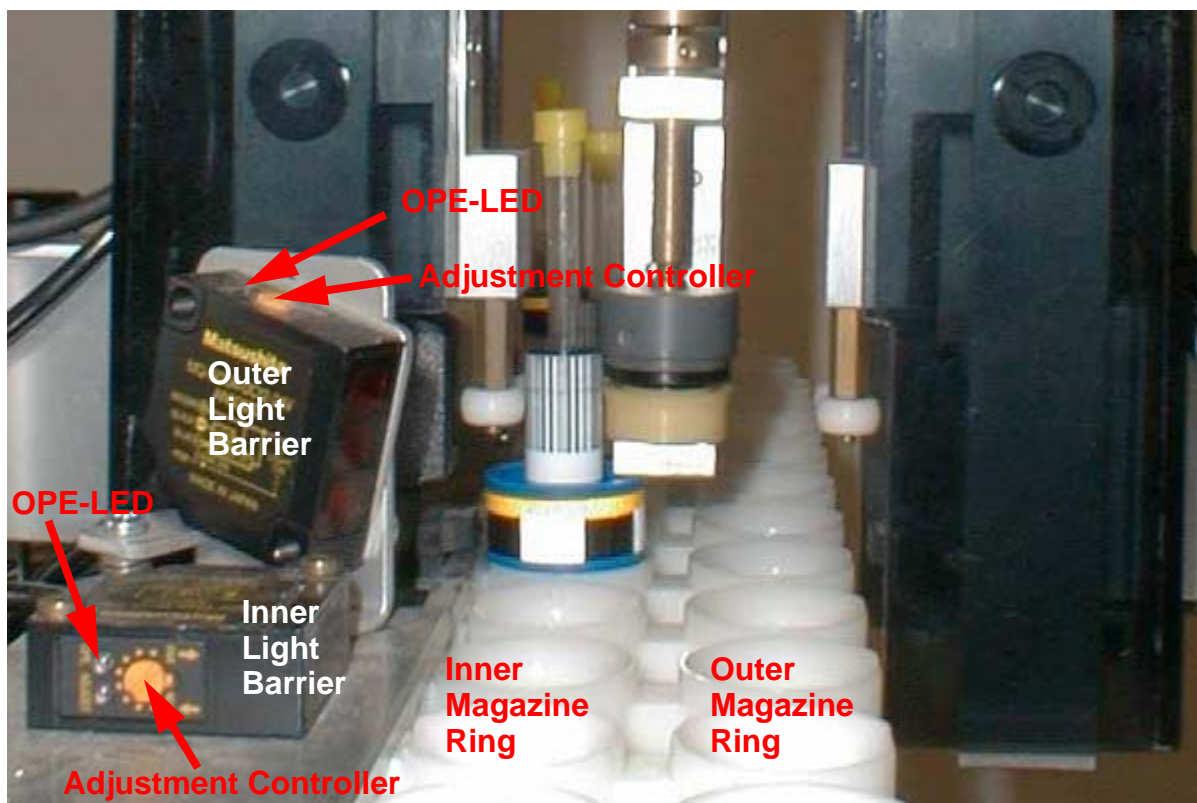

Figure 11.10. Light Barrier at the Magazine

If this adjustment is not suitable, please try the following:

1. Inner Magazine Ring

- Put a sample into the OUTER magazine ring and turn the adjustment controller of the INNER light barrier clockwise, until the sample is detected (OPE-LED sensor lights).
- Now turn the adjustment controller of the INNER magazine counter-clockwise, until the sample detection vanishes.
- Turn the controller between this position and the stop position “Near”.

2. Outer Magazine Ring

- Put a sample into the OUTER magazine ring and turn the angular adjustment controller of the OUTER light barrier to position “Near”. The OPE-LED should now be out.
- Turn the controller to the position “Far” until the sample is detected (until the LED lights). **Remember this position!**
- Remove the sample.
- Hold your hand about 5 cm from the outer magazine ring. Turn the controller towards the “Far” position until your hand is detected, then it back until the hand is no longer detected. **Remember this position!**
- Adjust the controller to exactly between these positions.

Note: This procedure avoids the problem of manual intervention around the magazine area being detected as a sample.

3. Now check that both light barriers are working correctly. Use the LED's at the sensor block.

- The upper LED lights, when no sample is detected on the inner ring.
- The lower LED lights, when no sample is detected on the outer ring.

Check with:

- With no sample present.
- With a sample in the outer magazine ring.
- With a sample in the inner magazine ring.
- With samples in the inner and outer magazine rings.

Check if the device works correctly with the inner light barrier:

- Check once with the white color of the spinner before the LED, once with black color.

In some cases a sample may be detected in the inner ring, even though there is only a sample in the outer ring. In this case a light reflection may cause this error. Readjust the light barrier to correct the problem

B-ACS RS232C Serial Link

11.4

In its standard configuration the B-ACS sample changer is able to handle 60 or 120 samples, and is controlled via a RS232C serial link. The sample changer software defines the transmission mode of the RS232 channel as follows:

7 data bits		7 data bits
parity „marked“	or	parity „none“
1 stop bit		2 stop bits

System Parameters

11.4.1

The following system parameters have to be adjusted or taken in consideration:

1. Transmission baud rate for RS232.

The standard value is 9600 baud, i.e. position 9. Factory settings: S1 = „C“, S2 = „9“.

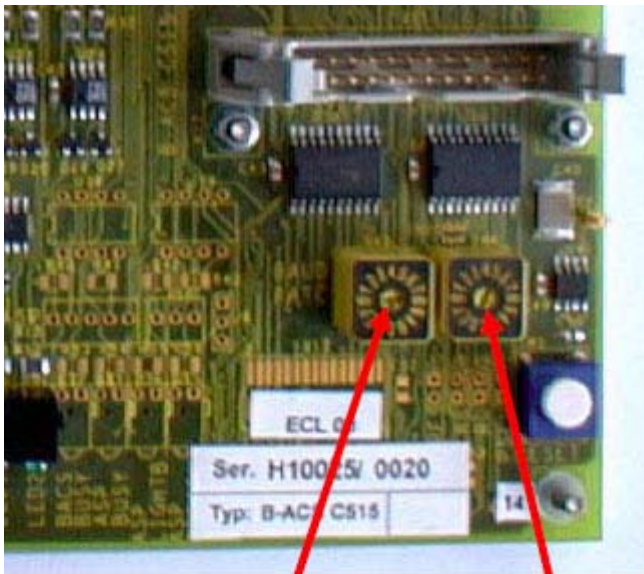

Hex Switch
Debug
(default *C*)

Hex Switch
Command
(default *9*)

Hex Switches

Debug Switch		Command Switch	
Baud Rate	Position	Baud Rate	Position
50	0	50	0
75	1	75	1
110	2	110	2
150	3	150	3
300	4	300	4
600	5	600	5
1200	6	1200	6
2400	7	2400	7
4800	8	4800	8
9600	9	9600	9 (default)
19200	A	19200	A
38400	B		
57600	C (default)		

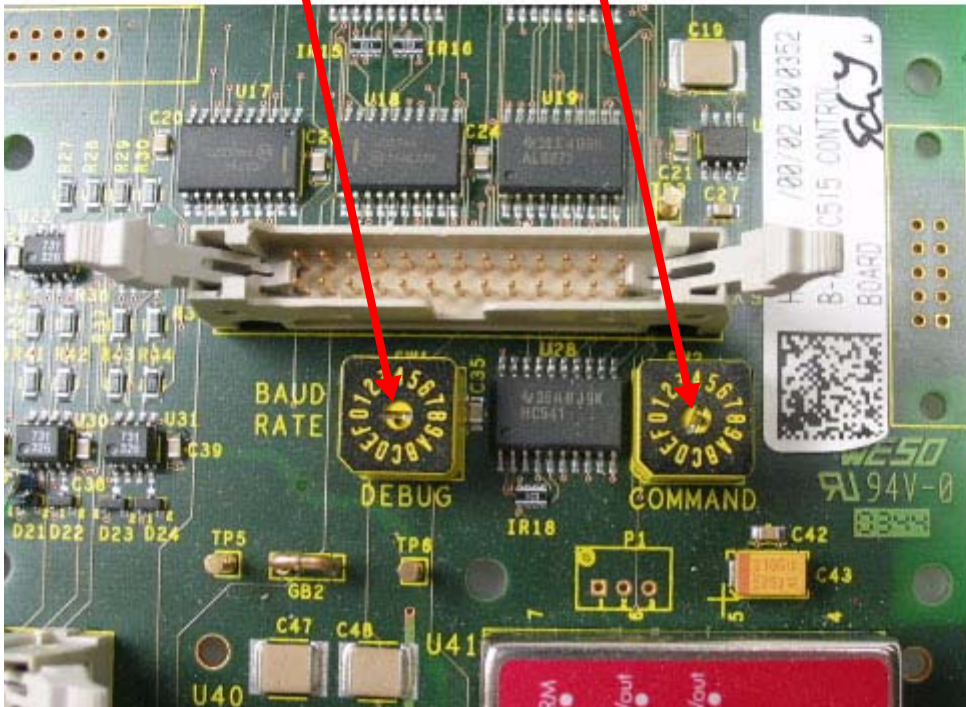

Figure 11.11.Main Control Board Hex Switches

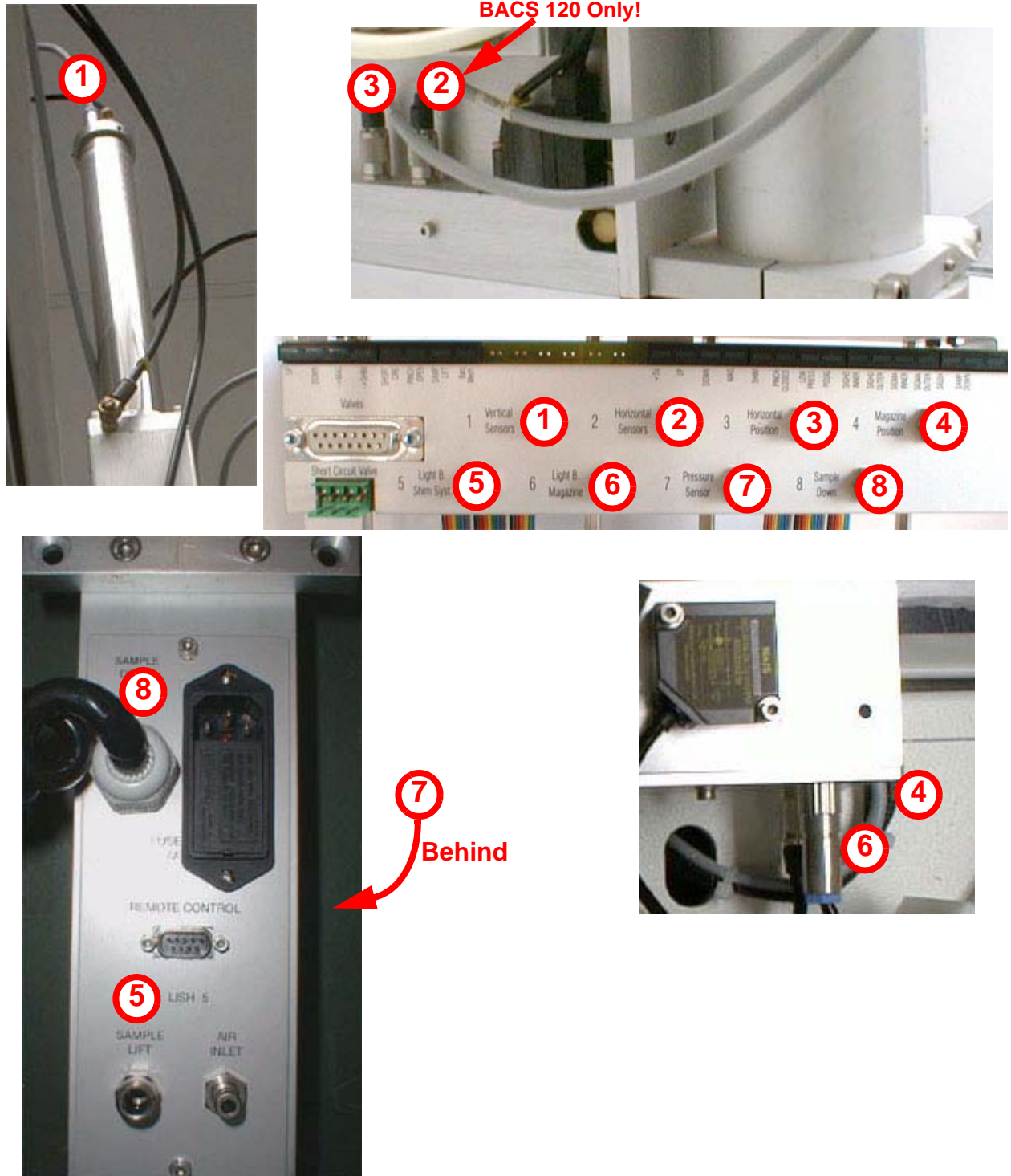

Figure 11.12. Connections for Operation

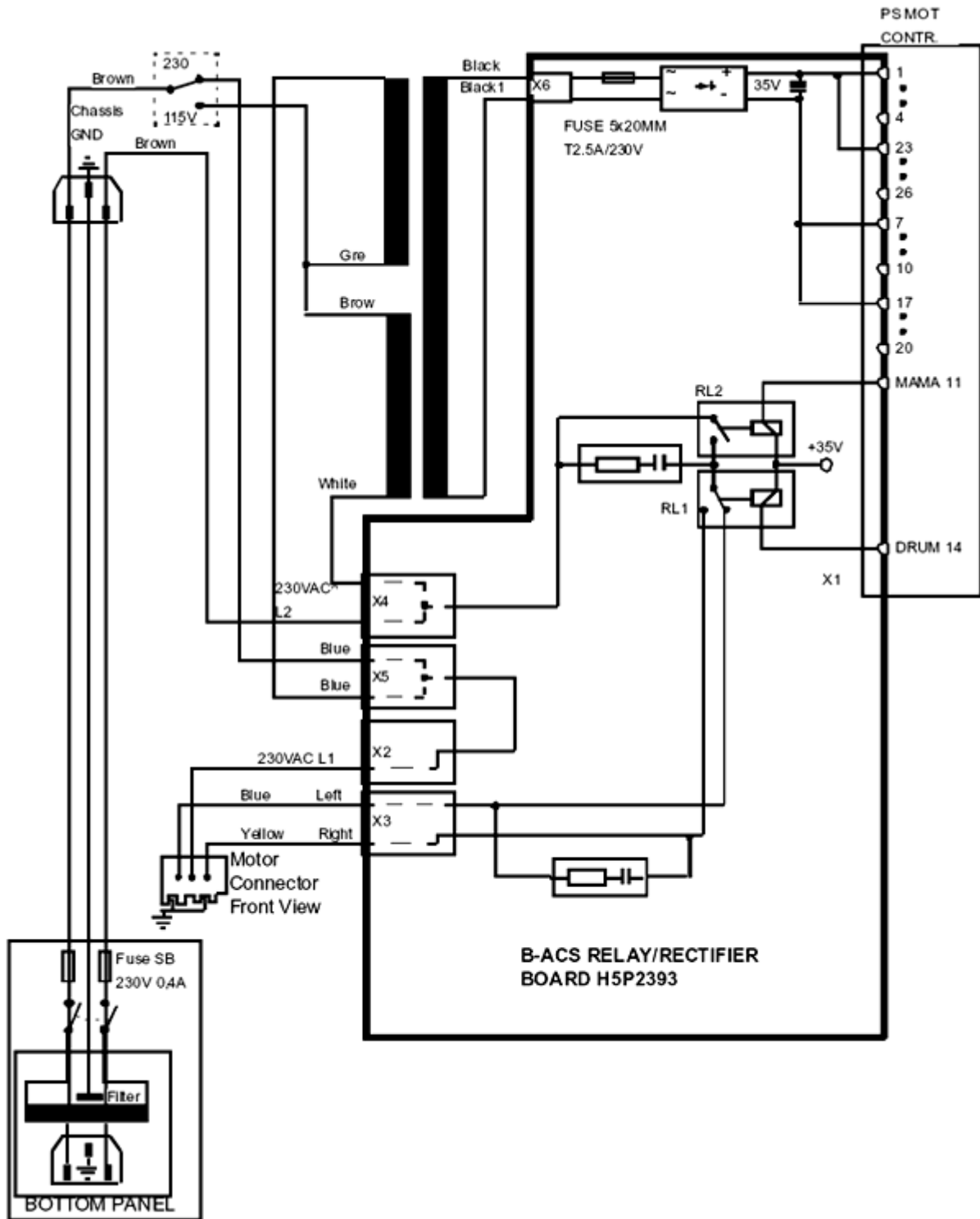

Figure 11.13. Power Supply Box Wiring Diagram

Barcode Reader Option

12

General

12.1

This chapter deals with the installation and operation of the following barcode reader options for the B-ACS 60 or 120:

- The standard Vertical Barcode Reader (section [12.2](#))
- Rotating Collar Barcode Reader (section [12.3](#)).



Vertical Barcode Reader

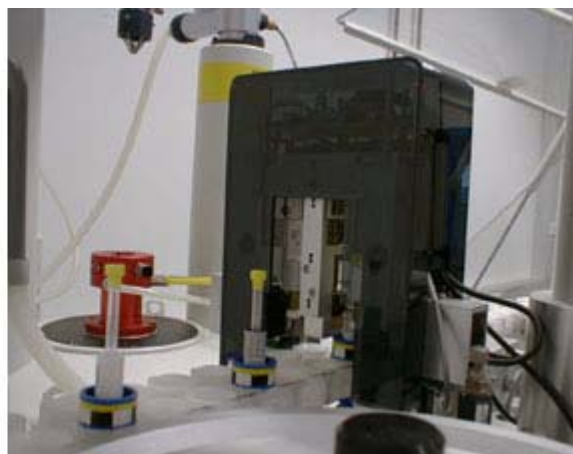

Rotating Collar Barcode Reader

Figure 12.1. Barcode Reader Units

The Standard Vertical Barcode Reader

12.2

The B-ACS Barcode Reader Vertical is available as a kit and can be ordered using the following part numbers:

- H9781 B-ACS 60 Barcode Reader Option Vertical
- H10112 B-ACS 120 Barcode Reader Option Vertical
- H10113 Set Barcode Collar Vertical Barcode (100 pieces)

The kits consist of a barcode reader mounted on a bracket (holder), the B-ACS Vertical Barcode Detection Board and the necessary cables needed to connect the reader(s) to the board.



Ensure that the power for the sample changer is off by pressing (or turning on newer models) the emergency stop button).

Preparing the Sample Changer and Barcode Reader Unit

1. Remove the outer cover of the barcode reader unit (loosen the black thumb screws on top of the cover).
2. Remove the rear panel of the sample changer cabinet.
3. Remove the metal support bracket located in the center of the rear of the cabinet, and slide the barcode detection cable (flat cable) of the reader unit through the rectangle slot on the top of the rear of the sample changer cabinet.

Mounting the barcode Reader Unit on the Cabinet

Mount the barcode reader unit to the top of the cabinet as shown in the following picture. Fasten the reader to the cabinet using the four Allen screws provided, but tighten the screws slightly, allowing for some movement of the reader unit for later adjustment.

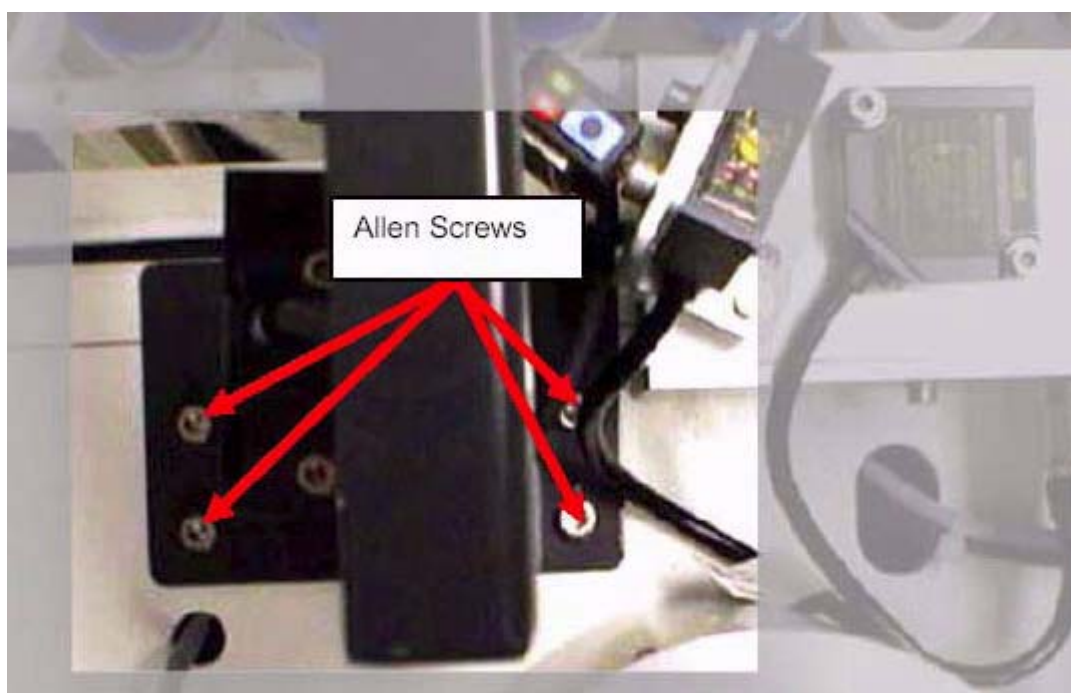

Figure 12.2. Placing the Barcode Reader Unit on the Cabinet

Installing the Barcode Detection Board

Open the front of the sample changer cabinet and mount the B-ACS barcode detection board on the top of the control board in the electronic housing. The board is held in place with two nuts as indicated in **Figure 12.3**.

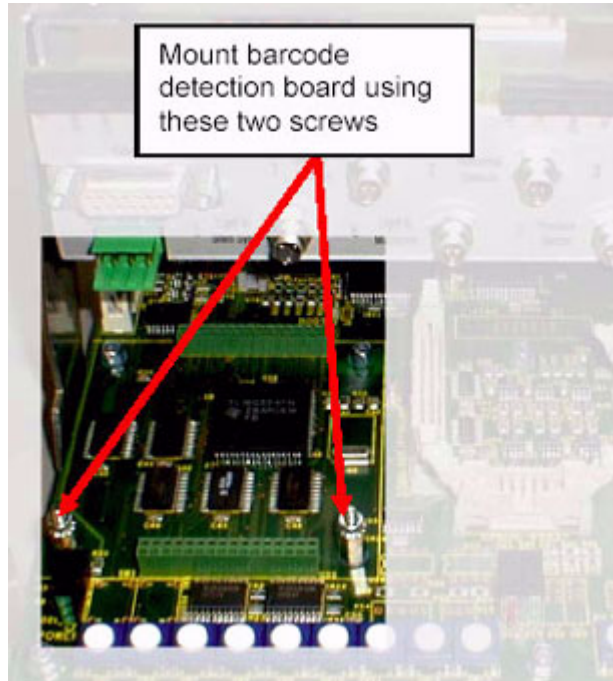

Figure 12.3. Mounting the Barcode Detection Board

Connect the 8-pin and RJ45 cables from the barcode reader and the reflective light sensors to the M60 plugs on the barcode detection board. If you are using the B-ACS 120, connect the M120 plugs as well. The cables and board are clearly marked to avoid confusion.

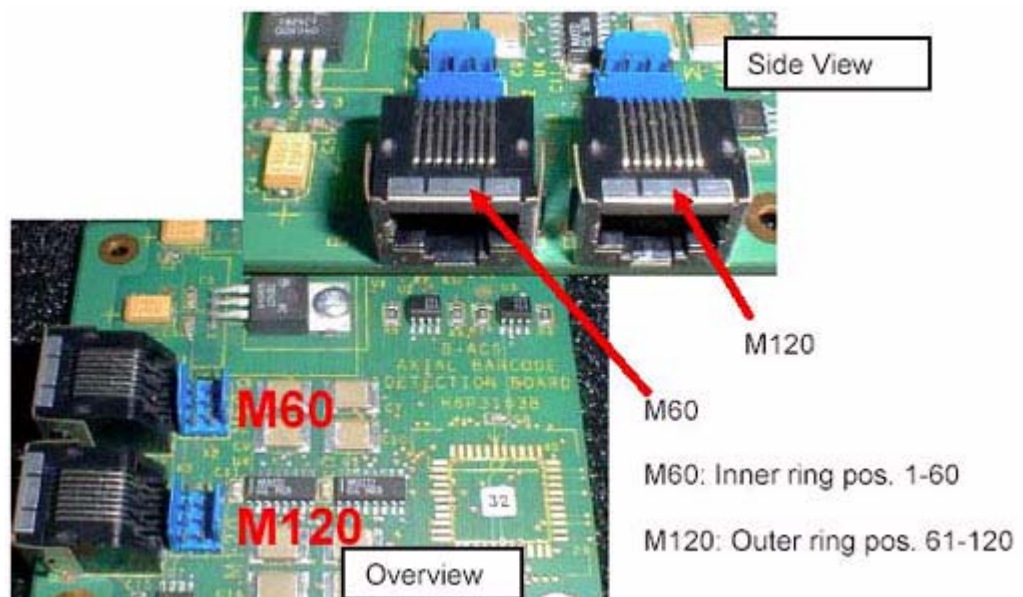

Figure 12.4. Cable Connectors

Putting the Barcode Reader Into Operation

12.2.2

Close the front panel of the sample changer, reconnect the power supply cable to the sample changer, and turn the sample changer on. Wait for the initialization to finish before continuing with the adjustment.

Prepare samples by placing a barcode collar from the set P/N H10113 on a sample. Insert the samples into the carousel belt positions near the barcode reader.

Move a sample tube with a barcode to the read position on the barcode reader by rotating the belt with the appropriate keyboard command. Type the following sample changer commands on the host computer keyboard:

<u>Instruction</u>	<u>Command</u>
Diagnostic Mode:	ESC . <ENTER>
Enter Barcode Length:	BD 4 <ENTER>
Begin Barcode Reader Test:	BT <ENTER>

The barcode reader should begin to read the barcode on the sample.

Adjusting the Threshold of the Reflex Sensors

12.2.3

On the side of the barcode reader unit are two reflex sensors. The green LED on top of the reflex sensor remains on and indicates that the unit is operational. Before the barcode reader unit can be used the threshold value must be set:

- With a sample on the carriage in the read position push the “Set” button on top of the reflex sensor once. The display will blink with the current value of reflective light and the text “SET”. Remove the sample from the carriage and push the “Set” button a second time.
- The threshold value will then blink 3 times. The sensor will then display the value of the currently reflected light intensity. When the sensor is operating correctly the orange LED will light when a sample is present, and will be off when no sample is present.
- Perform this step on both the inner and outer reflex sensors if using a B-ACS 120 sample changer.

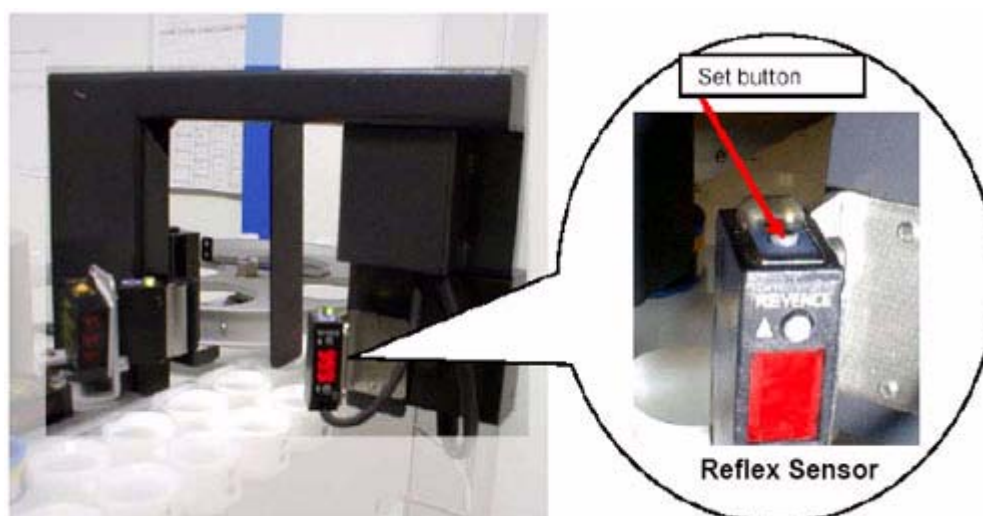

Figure 12.5. Adjusting the Reflex Sensors

Rotating Collar Barcode Reader (old version)

12.3

This sections deals with the installation and operation of the barcode reader option for the B-ACS 60 or 120.

Required parts (refer to **Figure 12.6**):

- barcode Detection Board
- barcode Detection Cable
- barcode Reader Unit (B-ACS 60 or B-ACS 120)
- barcode Pressure Reducer with Manometer and Pneumatic Hose (0)
- Additional Pneumatic Hose (0)

B-ACS 60 Barcode Reader Unit

B-ACS 120Barcode Reader Unit

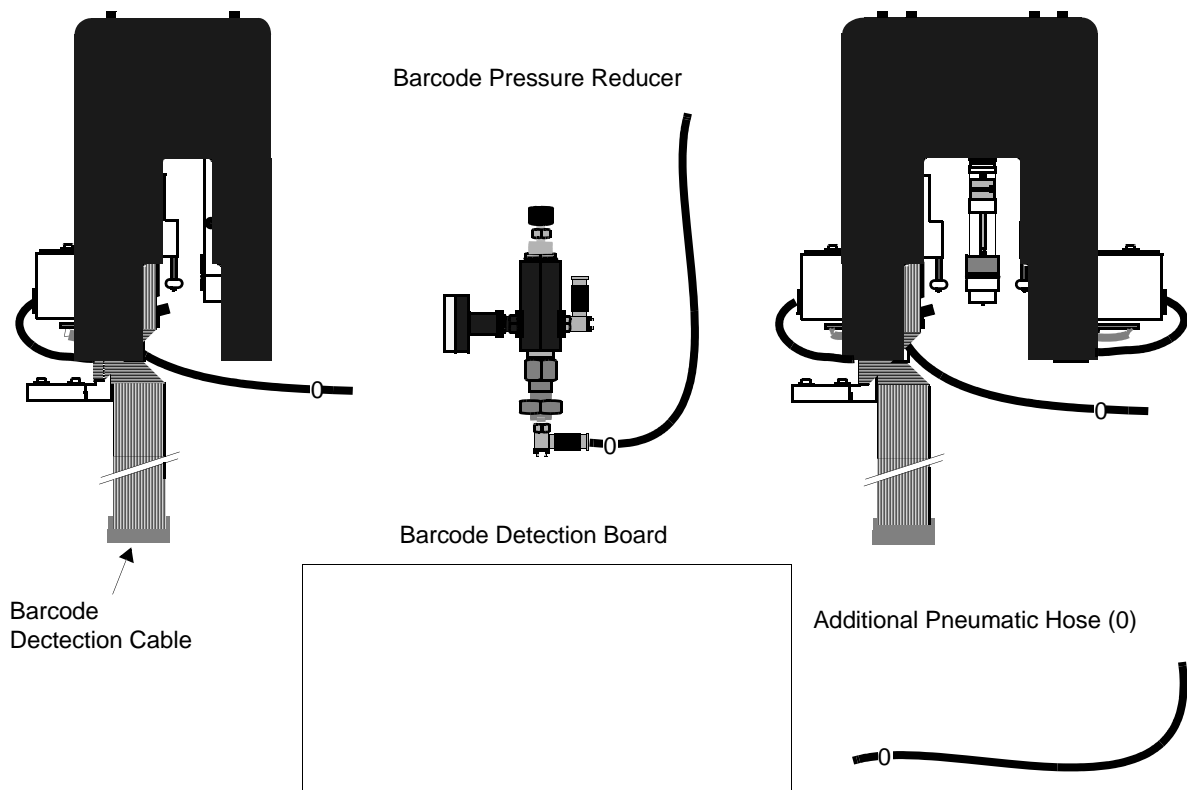

Figure 12.6. Parts Required for Installation of the Barcode Reader



WARNING: Disconnect the Sample Changer from its power supply before proceeding.

Installing the Barcode Detection Board

Insert the barcode detection board into the free slot of the electronic assembly inside the automatic sample changer (second slot from the left).

Preparing the Sample Changer and Barcode Reader Unit

Remove the outer cover of the Barcode Reader Unit (loosen the black thumb screws on top of the cover).

Remove the rear panel of the Sample Changer Cabinet.

Remove the metal support bracket located in the center of the rear of the cabinet, and slide the Barcode Detection Cable (flat cable) of the Reader Unit through the rectangle slot on the top of the rear of the sample changer cabinet.

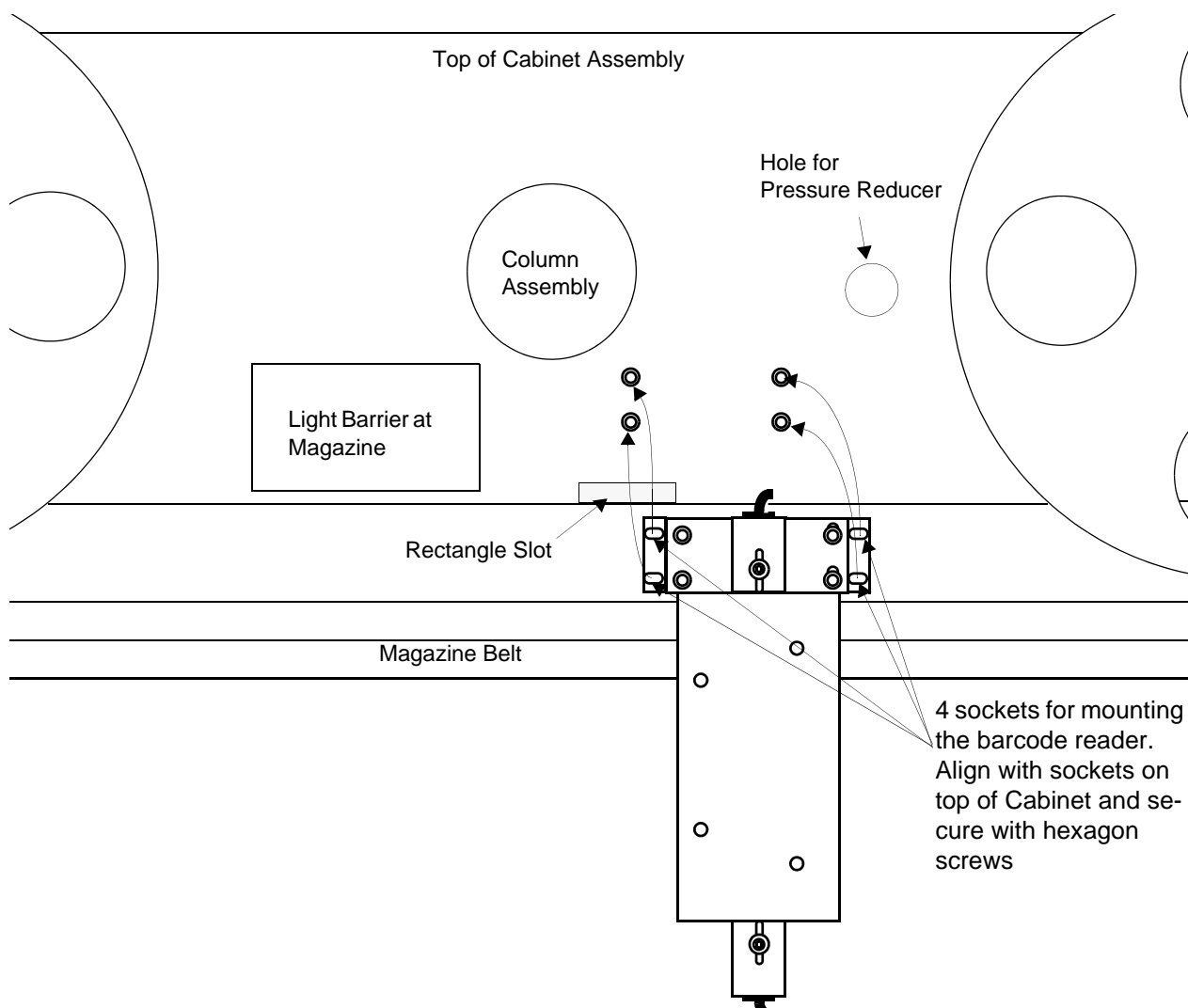

Figure 12.7. Placing the Barcode Reader Unit on the Cabinet

Mounting the Barcode Reader Unit on the Cabinet

Mount the Barcode Reader Unit over the cabinet and sample belt carousel, aligning the four hexagon socket head cap screws over the holes in the top of the cabinet (**Figure 12.7**). Tighten the screws slightly, allowing for some movement of the reader unit for later adjustment.

Adjust the reader unit to ensure a uniform contact of the wheels on the barcode sleeve (see x). The sample position between the guide wheels must be checked carefully. Move the Unit forwards or backwards, then left or right to adjust the position.

Connect the end of the barcode detection cable to the barcode detection board.

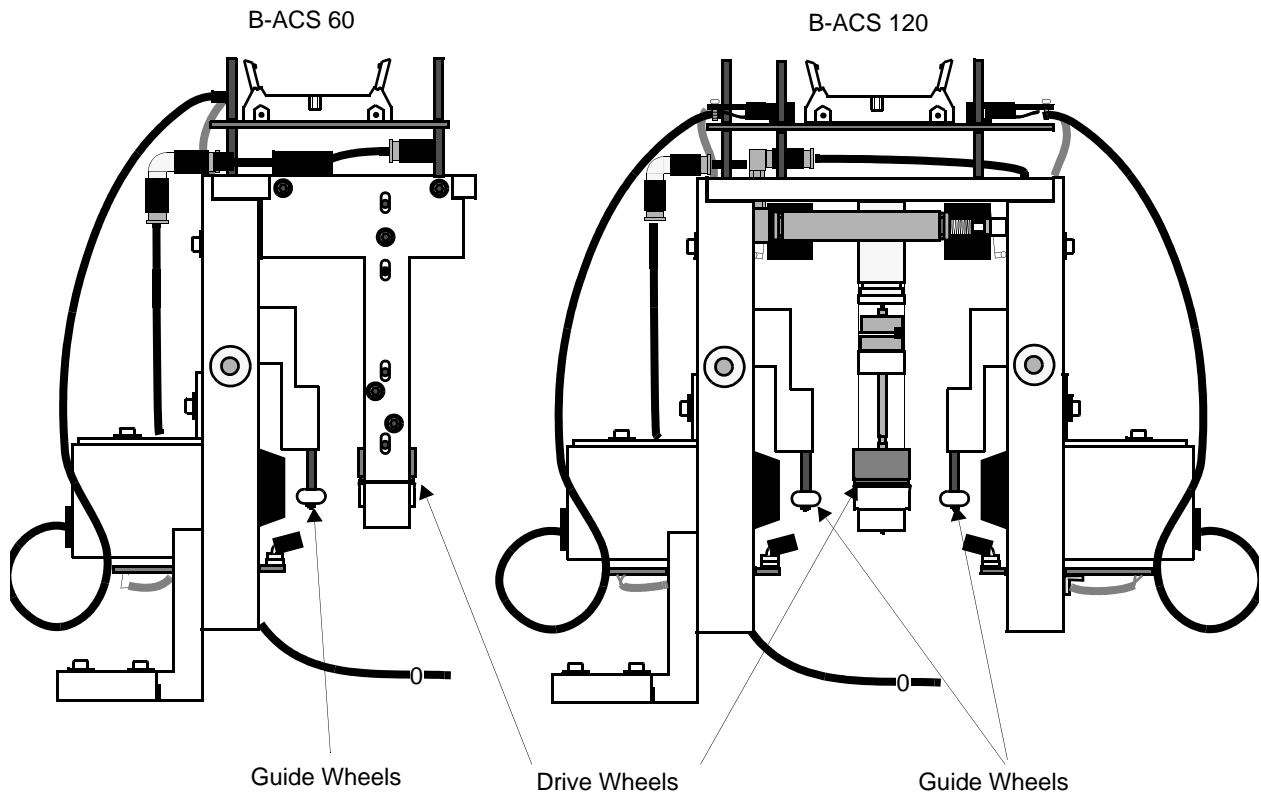

Figure 12.8. Location of the Guide and Drive Wheels

Mounting the Barcode Pressure Reducer

1. Mount the barcode pressure reducer (with manometer) by placing it in the round hole provided at the top of the cabinet (refer to (**Figure 12.2**) and **Figure 12.9**). Secure the unit with the hexagon nut. Place the upper pneumatic hose connector with hose onto the lower end of the pressure reducer and screw it on tightly.
2. Connect the lower pneumatic hose (#0) from the bottom of the pressure reducer to the pneumatic connector (position 0) on the valves and motor control board.
3. Connect the upper pneumatic hose (#0) from the reader unit to the upper pneumatic hose connector on the pressure reducer.

Barcode Reader Option

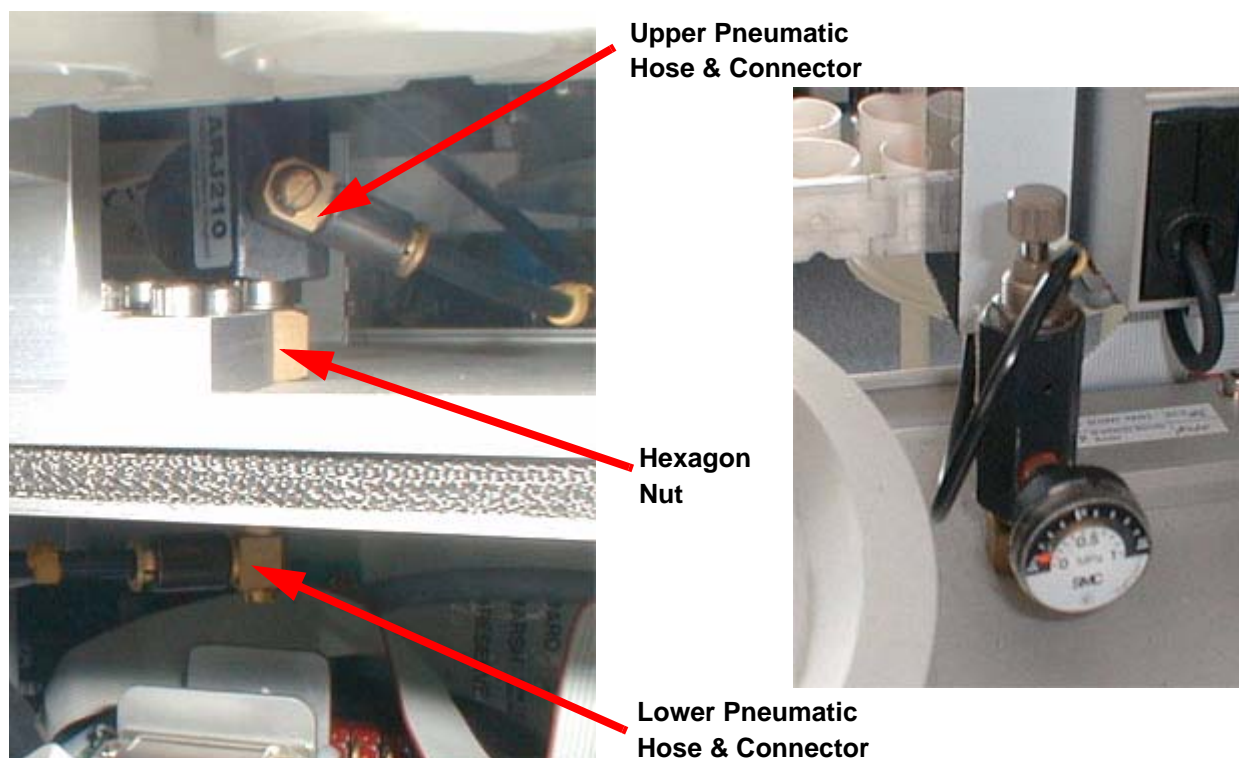

Figure 12.9. Barcode Pressure Reducer with Manometer

Putting the Barcode Reader Into Operation

12.3.2

Reconnect the power supply cable to the sample changer and turn the sample changer on.

Prepare samples by printing and placing a barcode label on each sample as indicated in the Barcode Printer manual. Insert the samples into the carousel belt positions near the Barcode Reader.

Adjusting the Air Pressure of the Barcode Reader

To adjust the air pressure of the barcode reader, run the following tests:

Move a sample tube with a barcode to the read position on the barcode reader by rotating the belt with the appropriate keyboard command.

Type the following sample changer commands on the host computer keyboard.

<u>Instruction</u>	<u>Command</u>
Diagnostic Mode:	ESC . <ENTER>
Enter Barcode Length:	BD 4 <ENTER>
Begin Barcode Reader Test:	BT <ENTER>

The Barcode Reader should begin to read the barcode on the sample.

Adjust the air pressure to approximately 4 bar (or until the sample spinner rotates freely) by turning the adjusting screw on top of the pressure reducer (**Figure 12.9**).

Note: If the RESET button is pushed you must re-enter the barcode length. To abort the test at any time, press CONTINUE.

Centering the Samples in the Barcode Reader

Center the samples between the guide and drive wheels by moving the Reader Unit towards or away from the column, then right or left. Once the samples are centered, tighten the hexagon screws holding the Reader Unit.

Adjusting the Scanner Optics on the Barcode Reader

With the samples still in the read position, adjust the scanner optics as follows:

If the barcode reader is not in the test mode, repeat the *ESC*, *BD 12*, and *BT* commands as mentioned above.

Loosen the screw on top of Scanner Optic Unit (if you have a B-ACS 120, the unit closest to the sample changer column) and adjust the optics by moving the unit forwards or backwards and up or down (**Figure 12.10.**). The distance between the label of the sample and the barcode reader optic is optimal when LED 2 on the barcode detection board flashes at regular intervals and LED 1 flickers. When the optimal distance has been obtained tighten the screw on top of the Scanner Optic Unit.

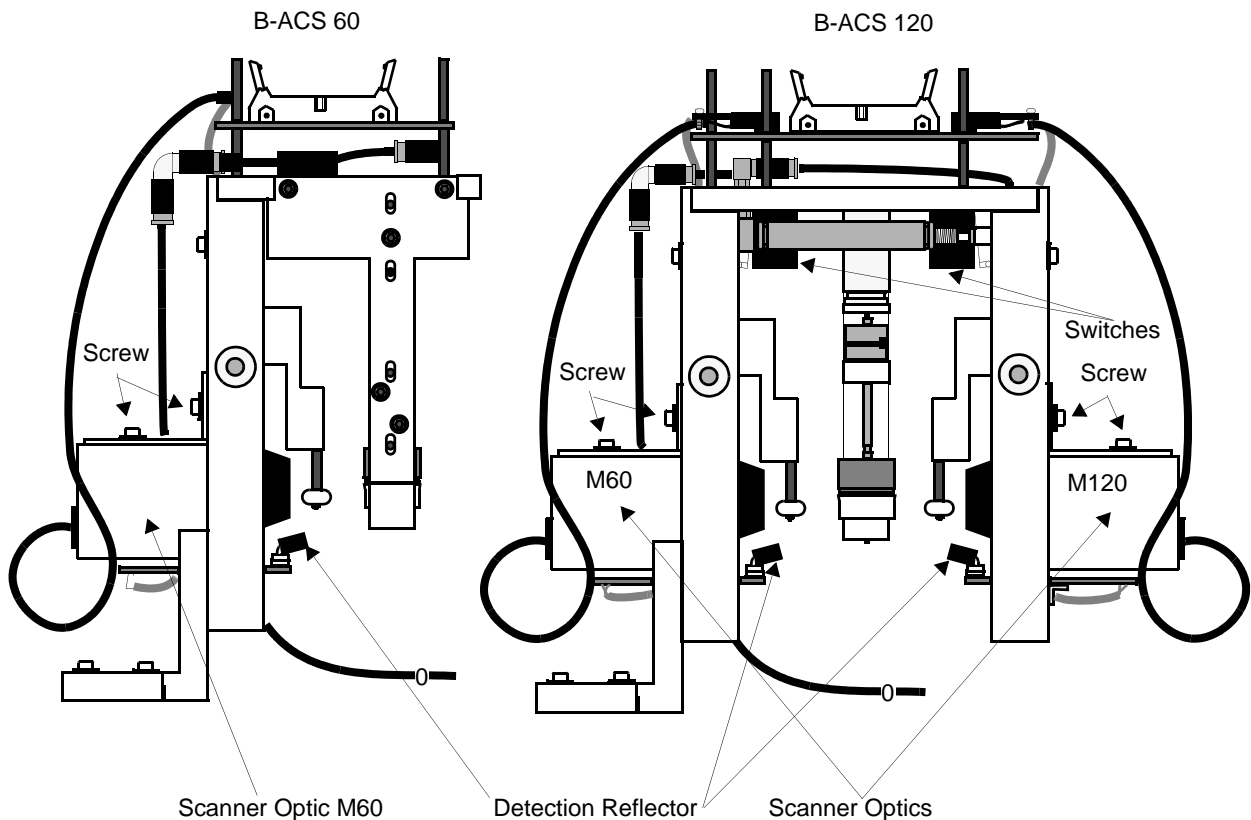

Figure 12.10. Location of the Scanner Optics

If you have a B-ACS 120 change the test to Channel B by pushing the ">," or "<" key on the front panel of the Sample Changer Cabinet and repeat the above step for the outer Scanner Optic Unit.

Barcode Reader Option

Note for B-ACS 120 Owners: A spinner in the outer position of the carousel should not be able to be detected by the inner spinner detector and vice-versa. If this should be the case then decrease the sensitivity of the spinner detection reflector by using the trim pod on the Barcode Adapter board.

Final Step

Once you have completed the adjustments, replace the Barcode Reader Unit cover and the back panel of the cabinet. This completes the installation of the Barcode Reader.

Test points on the Adapter Boards

12.3.3

M120

TP1:	LIGHT BARRIER SIGNAL M60
TP2: +5V	LIGHT BARRIER SUPPLY LB M60
TP3:	BARCODE SIGNAL M60
TP4:	LIGHT BARRIER SIGNAL M120
TP5: +5V	LIGHT BARRIER SUPPLY LB M120
TP6:	BARCODE SIGNAL M120

M60

TP1:	LIGHT BARRIER SIGNAL M60
TP2: +5V	LIGHT BARRIER SUPPLY LB M60
TP3:	BARCODE SIGNAL M60

Communication Protocols for the Thermo-printer V3.1

12.3.4

The DIP switch settings for setting the parameters are located on the rear of the printer (refer to the printer description)

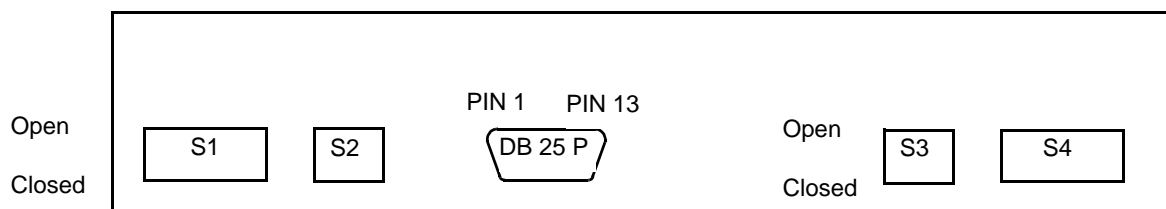

Figure 12.11. Rear Side of Label Printer

Table 12.1. Serial Interface Switch Positions

Serial Interface Switch Position

Switch S1	V24 input and output data are inverted, 2 stop bits, 7 or 8 data bits, no parity. S1.1 = Closed S1.2 = Closed S1.3 = Open S1.4 = Open S1.5 = Closed S1.6 = Closed S1.7 = Open S1.8 = Depends on the computer used.
Switch S2	Baud Rate = 9600 bauds S2 = 7
Switch S3	Automatic Form Feed until TOF, print speed and without XON-XOFF protocol. S3.1 = Closed S3.2 = Open S3.3 = Open S3.4 = Closed
Switch S4	Preset the delay time to 1400 msec, the label set to 39mm and with label synchronization. S4.1 = Open S4.2 = Open S4.3 = Open S4.4 = Closed S4.5 - S4.8 = Closed

DIP Switch Setting Overview for the F&O Label Printer

12.3.5

Table 12.2. Label Printer Connected to ASPECT and Station

Switch 1:	<table border="1" style="display: inline-table; border-collapse: collapse;"> <tr> <td style="width: 20px; height: 20px;"></td> <td style="width: 20px; height: 20px;"></td> <td style="width: 20px; height: 20px; text-align: center;">X</td> <td style="width: 20px; height: 20px; text-align: center;">X</td> <td style="width: 20px; height: 20px;"></td> <td style="width: 20px; height: 20px;"></td> <td style="width: 20px; height: 20px; text-align: center;">X</td> <td style="width: 20px; height: 20px;"></td> </tr> <tr> <td style="width: 20px; height: 20px; text-align: center;">X</td> <td style="width: 20px; height: 20px; text-align: center;">X</td> <td style="width: 20px; height: 20px;"></td> <td style="width: 20px; height: 20px;"></td> <td style="width: 20px; height: 20px; text-align: center;">X</td> <td style="width: 20px; height: 20px; text-align: center;">X</td> <td style="width: 20px; height: 20px;"></td> <td style="width: 20px; height: 20px; text-align: center;">X</td> </tr> </table>			X	X			X		X	X			X	X		X	Open Closed
		X	X			X												
X	X			X	X		X											
	1 2 3 4 5 6 7 8																	

Table 12.3. Label Printer Connected to IBM-PC

Switch 1:	<table border="1" style="display: inline-table; border-collapse: collapse;"> <tr> <td style="width: 20px; height: 20px;"></td> <td style="width: 20px; height: 20px;"></td> <td style="width: 20px; height: 20px; text-align: center;">X</td> <td style="width: 20px; height: 20px; text-align: center;">X</td> <td style="width: 20px; height: 20px;"></td> <td style="width: 20px; height: 20px;"></td> <td style="width: 20px; height: 20px; text-align: center;">X</td> <td style="width: 20px; height: 20px; text-align: center;">X</td> </tr> <tr> <td style="width: 20px; height: 20px; text-align: center;">X</td> <td style="width: 20px; height: 20px; text-align: center;">X</td> <td style="width: 20px; height: 20px;"></td> <td style="width: 20px; height: 20px;"></td> <td style="width: 20px; height: 20px; text-align: center;">X</td> <td style="width: 20px; height: 20px; text-align: center;">X</td> <td style="width: 20px; height: 20px;"></td> <td style="width: 20px; height: 20px;"></td> </tr> </table>			X	X			X	X	X	X			X	X			Open Closed
		X	X			X	X											
X	X			X	X													
	1 2 3 4 5 6 7 8																	

Barcode Reader Option

Switch 2:

f
7

 Rotary Switch
For
Baud Rate

Switch 3:

	X	X	
X			X

 Open
Closed

1 2 3 4

Switch 4:

X	X	X					
			X	X	X	X	X

 Open
Closed

1 2 3 4 5 6 7 8

Label Handling

12.3.6

When placing the barcode label onto the collar of the sample, make sure the label is fastened correctly. The label should be fixed parallel on the collar, with no overhang and no fold over.

To remove the label from the collar, lay the collar for a short time in methanol or a similar solvent.

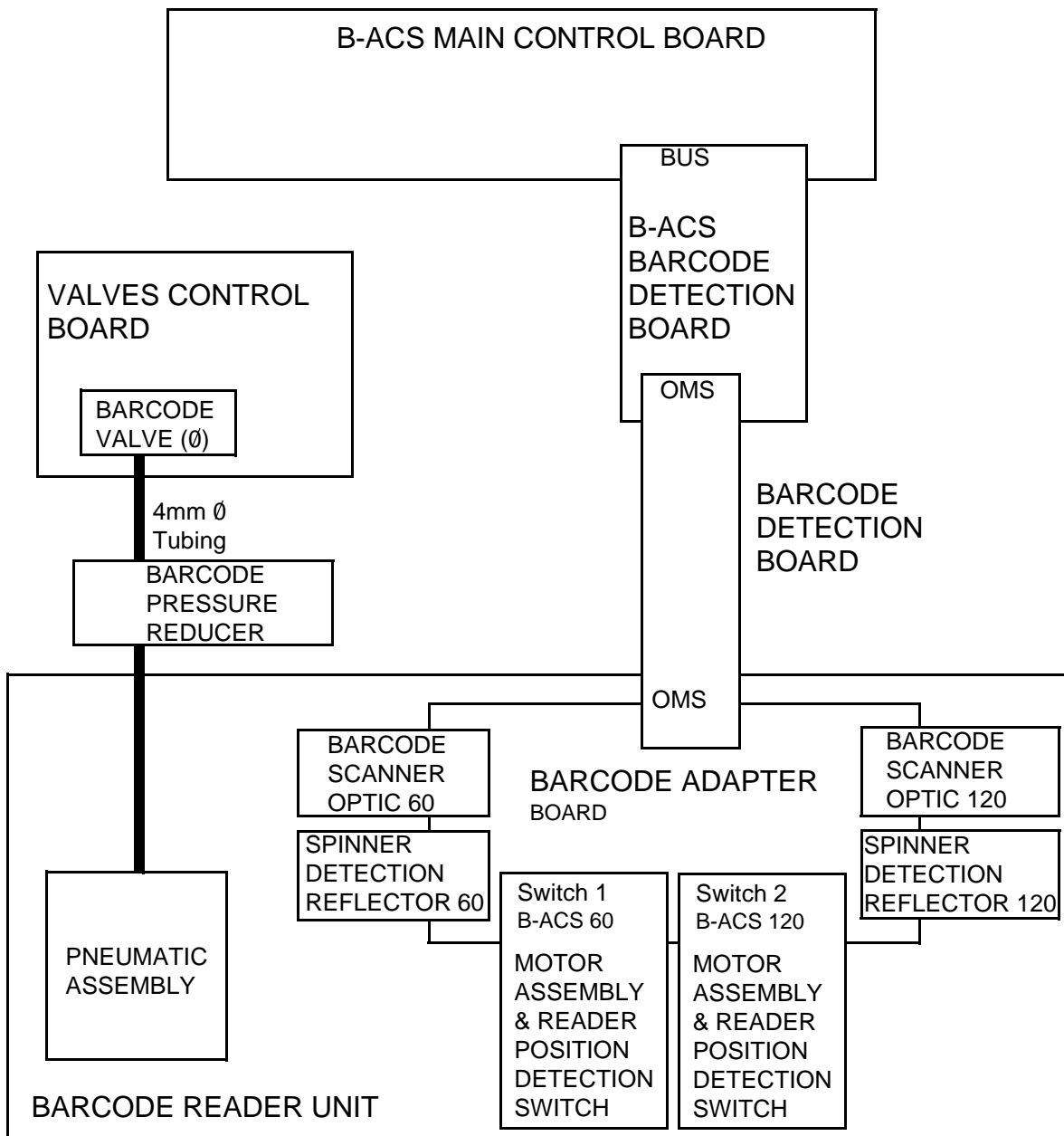

Figure 12.12. Barcode Reader Block Diagram

Barcode Reader Option

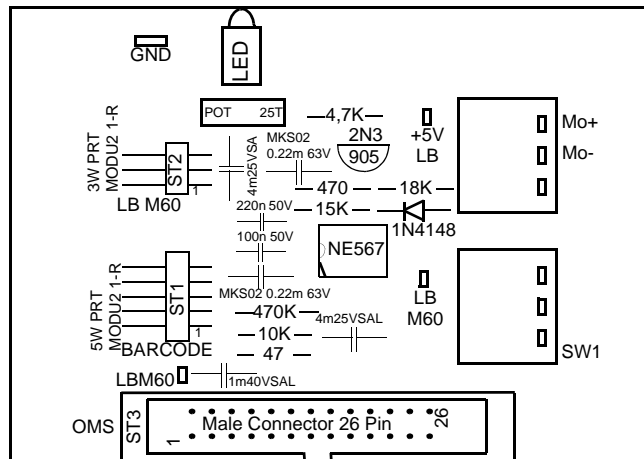

Figure 12.13. Barcode Adapter Board Component Layout B-ACS 60

Trimpot for adjusting sample detection distance
LED indicator lights if a sample is detected
LED Indicator
Trimpot for outer ring magazine

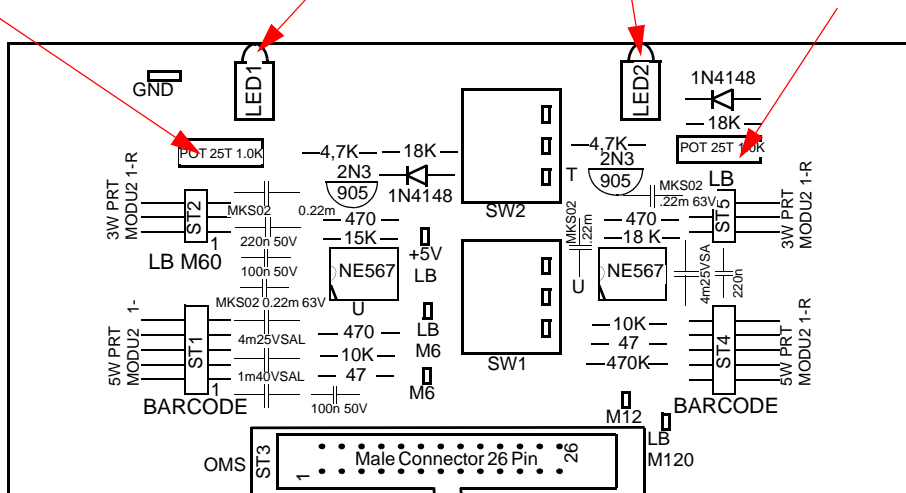

Figure 12.14. Barcode Adapter Board Component Layout B-ACS 120

Sample Heater Option

13

General

13.1

The B-ACS Sample Heater 120C is used in connection with the Bruker Automatic Sample Changer (B-ACS 60, B-ACS 120) for NMR Spectrometers.

Using the B-ACS sample heater it is possible to preheat NMR probes to a range of +30°C and +120°C depending upon the ambient temperature.

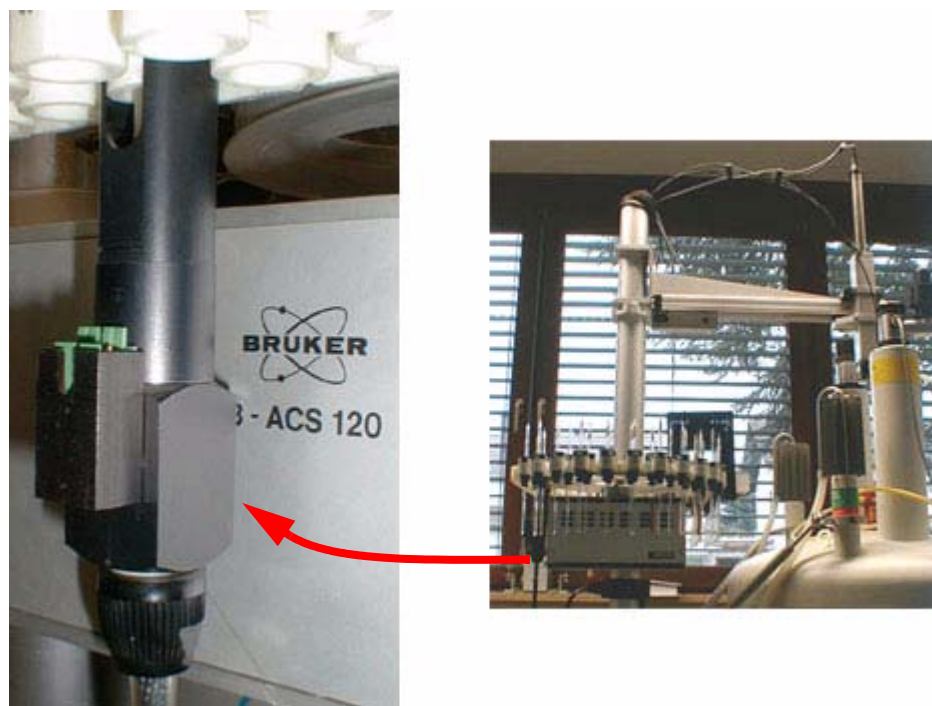

Figure 13.1. The B-ACS Sample Heater 120C

Before installing the sample heater, the points must be observed:

1. New B-ACS Light Barrier Magazine must be present.

The new Sample Changer must have a new version of the Light Barrier Magazine. If this is not the case, it must be exchanged for our new one, because the Magazine belt will not turn with the Sample Heater using the old Light Barrier.

Therefore if you are using the old version B-ACS 60 Part No. H1082, or the old version B-ACS 120 Part No. H655, you will need to replace it with the new version B-ACS 60 / Part No. H1402, or the B-ACS 120 Part No. H1403.

In addition, a sliding ring for transmission from the DC power supply, must be placed directly under the cabinet (see **Figure 13.2**).

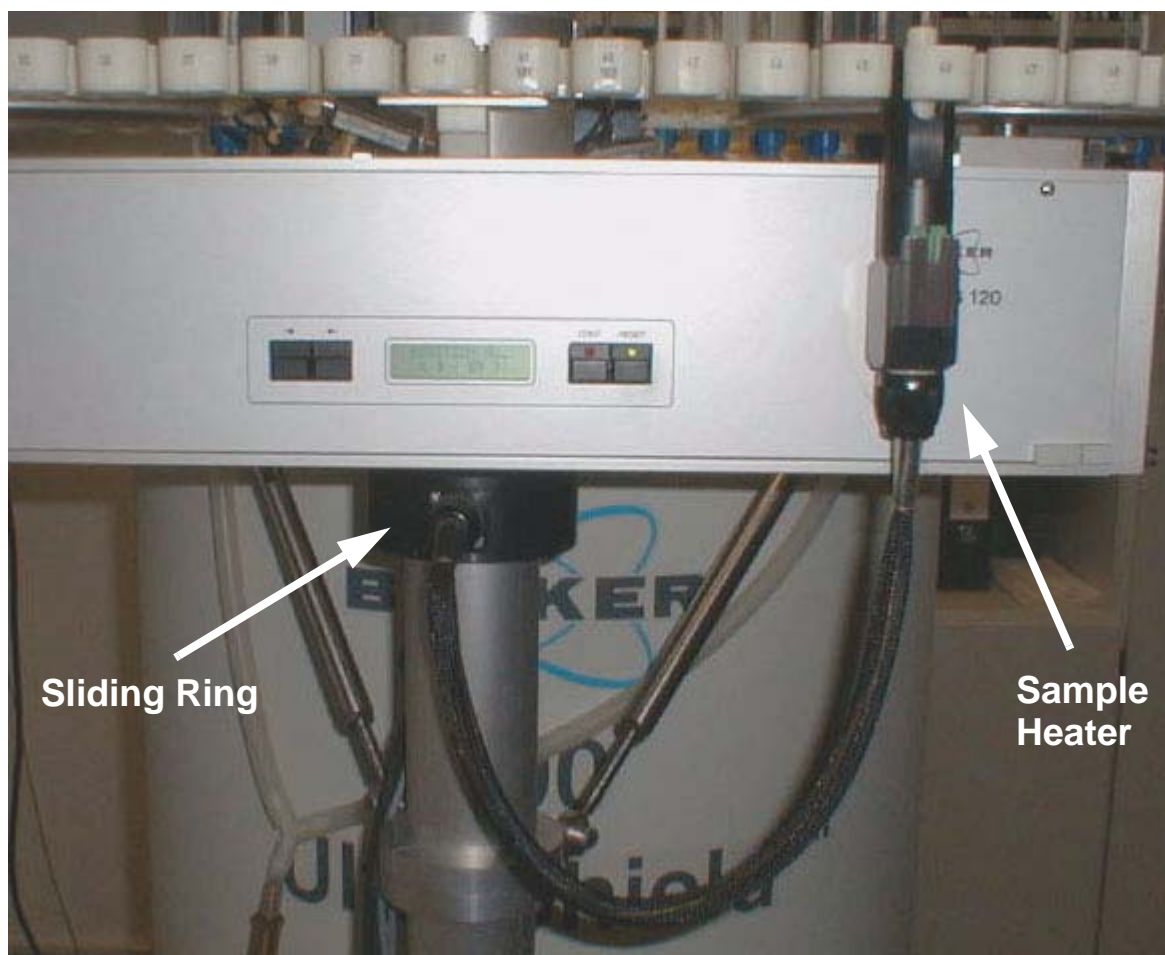

Figure 13.2. The B-ACS Sample Heater Mounted on the Cabinet Assembly

2. For operation of Sample Heaters the following units must be present:

- B-ACS Heater Power Supply Cpl. Part No. H1491 for DC-supply.
- B-ACS Sample Heater(s) 120C Part No. H1385 (**Figure 13.2.**).

Table 13.1. B-ACS Heater Supply Kit

Part Number	Description
H1455	B-ACS Heater Power Supply (Figure 13.6.) or (Figure 13.7.)
H5806	B-ACS Heater Supply 2 (Figure 13.4.)
H5886	B-ACS Sliding Ring (Figure 13.2.)
H1496	Cable RD 6P10000
3000	Cable RD ST Netz

Warning: Extreme Temperatures

13.3

The sample warmer located on the magazine belt reaches extreme temperatures: **Warning:** Do not insert your fingers into the sample warmer. When the sample warmer is operating it can reach temperatures exceeding 70°C (figure 3.1).

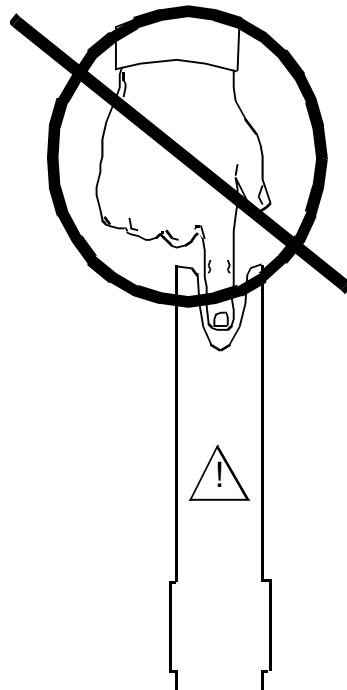

Warning! Extreme Temperature!
Do not put your finger into the sample warmer!

Figure 13.3. Extreme Temperature Warning

To install the sample heater, the following procedures must be performed:
Snap the Sample Heaters directly onto the Magazine Belt.



Note: When using the B-ACS 120 Sample Changer, use the inside chain positions for installation of the heaters. The outside positions, next to the positions used for the heaters, can not be used for samples as this would result in the PWR24 cables being disturbed.

Connect the heaters together using PWR24 cable (Part No. H1484), the first heater to the second, the second heater to the third, and so on forming a chain as illustrated in **Figure 13.4.**

The B-ACS Heater Supply 2 (**Figure 13.4.**) has a fixed pin inside to signify a busy position.

If you are installing the maximum number of heaters (30), then the Heater Supply 2 (Part/No. H5806) should be positioned in the middle, leaving 15 samples on each side of the supply chain.

Connect the Power Supply (Part/No. H1455) to the sliding ring (Part/No. H5886) under the cabinet using the enclosed cable (**Figure 13.2.**).

Connect the sliding ring (Part/No. H5886) to the Heater Supply 2 (**Figure 13.2.**).

The Power Supply, should be placed a minimum of 2 meters away from the magnet.

After switching on the power supply, the green LED in front of the Heater Supply should be on. The adjustment of the nominal temperature is accomplished by using the milled knob on the lower position of the heater.

The desired temperature (look on the knob) is selected by aligning the required scale value with the white marker on the heater.

The red LED displays the heater condition.

During the heating cycle the red LED should be on.

After reaching the selected temperature, the red LED should turn off.

LED ON signifies heating cycle.

LED OFF signifies that the nominal temperature has been reached

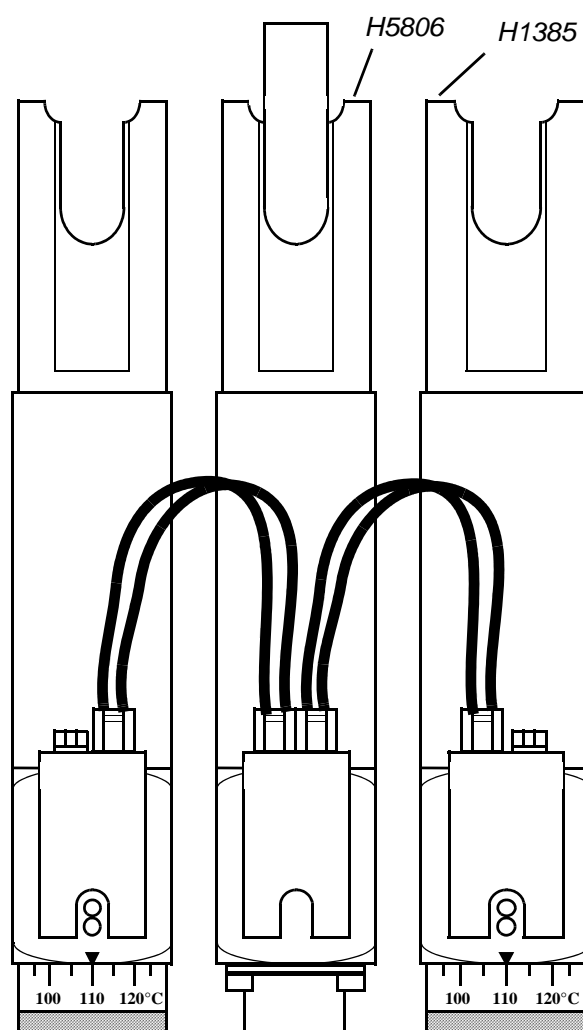

Figure 13.4. B-ACS Sample Heater

Start-up

13.6

The B-ACS Sample Heater 120C operates between **+30°C and 120°C**. After switching on the power supply, the green LED in front of the sample heater is on.

The adjustment of nominal temperature is accomplished using the middle knob on the lower position of the heater.

The red LED displays the heater condition.

Test conditions

13.6.1

- Sample tube 10 mm
- Filled with oil to a height of 65 mm
- Temperature measured with digital thermometer

Table 13.2. Test measure

Position of tuning knob	Oil temperature reached
30°C	30°C
60°C	59°C
90°C	92°C
120°C	122°C

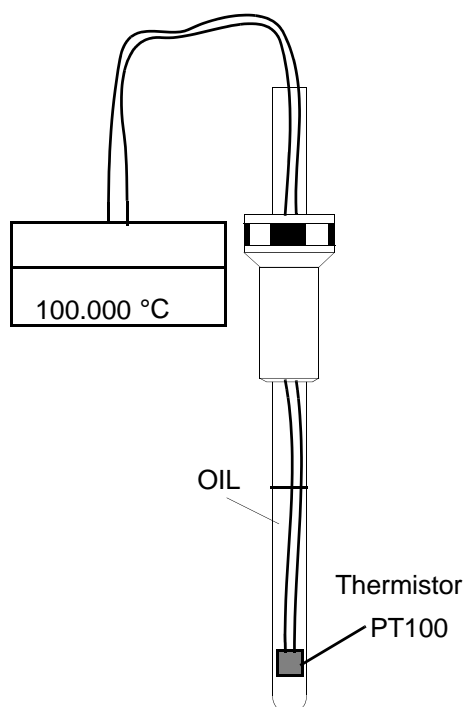

Figure 13.5. Test Measure

B-ACS Heater Power Supply

13.7

The B-ACS Heater Power Supply (Part No. H1455) is used in connection with the B-ACS Sample Heater 120C (Part No. H1385).

The Unit used up to series No.34, contains two PK100 (Part No.14514) modules from Vero, each 22-26V / 5A, so the Power Supply will run at a maximum of 10A (**Figure 13.6.**).

The Unit at series No. 35 contains one PK240 (Part/No.16524) module from Vero 22-26V/10A (**Figure 13.7.**).

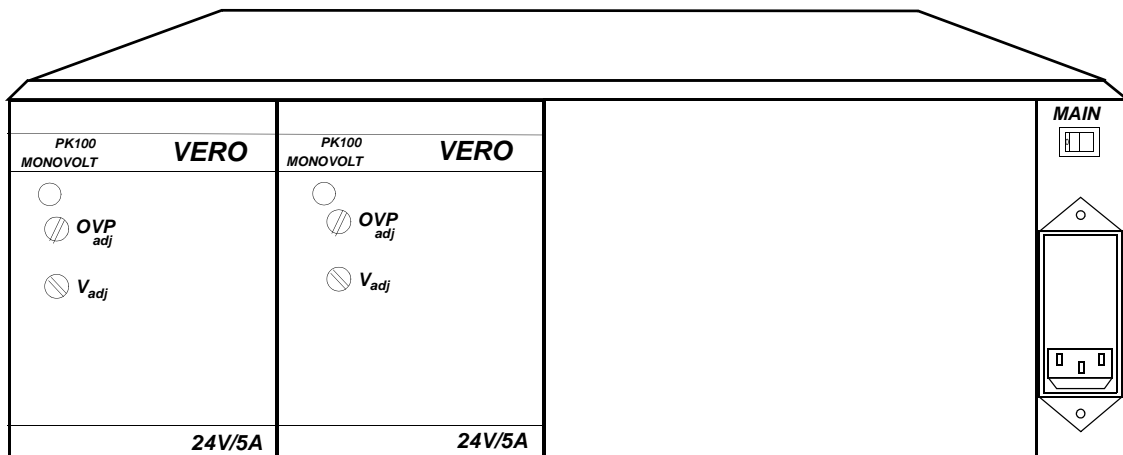

Figure 13.6. Heater Supply (used until Serial No. 34)

Take out one of the two power Modules (PK100) and perform the following steps with the remaining one.

Adjustment Of The Over-voltage Protection (OVP)

To adjust the OVP the sense lines must be connected over a 100 Ω / 10Watt Resistor and the over voltage protection measured directly on the output voltage connector.

Adjust the OVP using the external pot on the front panel of the Power Supply named OVP_{adj}.

Here the OVP = 30V.

Adjustment Of The Output Voltage (Vout)

With parallel operation, each output voltage must be adjusted as closely as possible to the same value, due to the equal current distribution in the units.

Connect the +Sense (Pin G) to the +UA (Pin A) and the -Sense (Pin E) to the -UA (Pin C) on the Burndy Connector located on the rear panel power supply.

Adjust the output voltage using the external pot on the front panel of the Power Supply, named V_{adj}.

Here the UA = 26V.

Sample Heater Option

Replace the power module that you removed previously and remove the module that has been adjusted. Repeat the steps listed above on the second module that is now present in the unit.



Do not shorten the sense lines, as this may cause damage to the power supply.

This adjustment is normally not required as the unit has already been correctly set by the manufacturer.

Connectors on the PK100 Supply Module

13.7.3

Table 13.3. H15 connector

PIN	FUNCTION
4,6	+UA
12,14	-UA
10	-Sensor
8	+Sensor
24	230VAC
26	230VAC Phase
32	Protected Earth

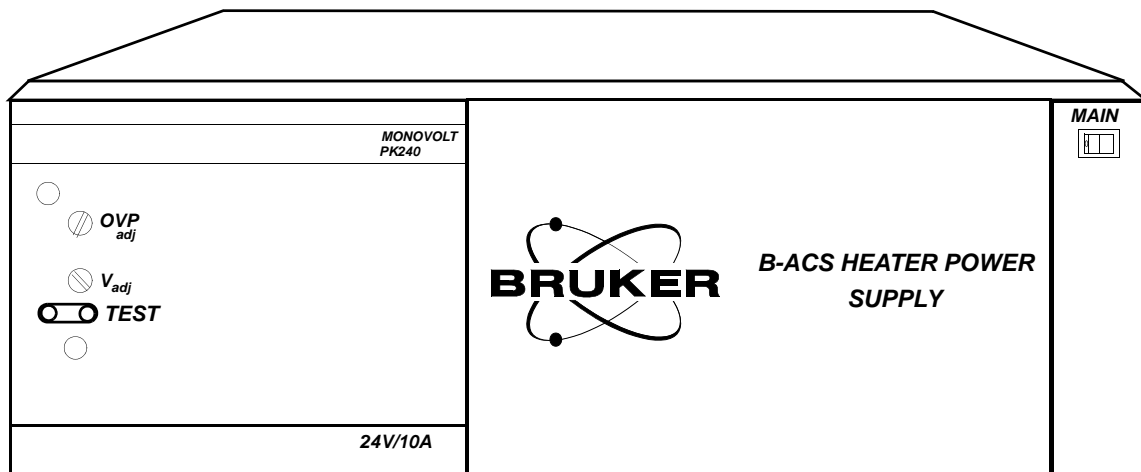

Figure 13.7. Heater Supply (after Serial No. 35)

Adjustment Of The Over Voltage Protection (OVP)

To adjust the OVP the sense lines must be connected over a 100 Ω / 10Watt Resistor and the over voltage protection measured directly on the output voltage connector or on the front-panel connector named TEST.

Adjust the OVP using the external pot on the front panel of the Power Supply, named OVP_{adj}.

Here the OVP = 30V.

Adjustment Of The Output Voltage (Vout)

Connect the +Sense (Pin G) to the +UA (Pin A) and the -Sense (Pin E) to the -UA (Pin C) on the Burndy Connector located on rear panel power supply.

Adjust the output voltage using the external pot on the front panel of the Power Supply, named V_{adj}.

Here the UA = 26V.

Sample Heater Option



Do not shorten the sense lines, as this may cause damage to the power supply.

This adjustment is normally not required as the unit has already been correctly set by the manufacturer.

Connector on PK240 Supply Module

13.7.6

Table 13.4. H15+2HA connector

PIN	FUNCTION
I	+UA
II	-UA
14	+Sensor
16	-Sensor
22	Ext. ON/OFF
24	Power fail-signal Q
28	230VAC
30	230VAC Phase
32	Protected Earth

Pin Assignment Rear Panel

13.7.7

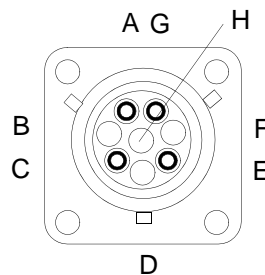

Figure 13.8. Burndy Connector B-ACS Heater Power Supply

Table 13.5. Burndy Connector B-ACS Heater Power Supply

PIN	FUNCTION	COLOR
A	+UA (26V)	brown/red
B	-----	
C	-UA (GND)	yellow
D	-----	
E	- SENS	yellow
F	-----	
G	+SENS	brown/red
H	-----	

Electrical characteristics**13.7.8**

Input Voltage 230V/50-60Hz

Fuses in main filter 2x1.6A/250V time lag

Output Voltage 22-26V/10A

500 MHz and 600 MHz SAG Magnets

A

Introduction

A.1

This is a supplement to the BRUKER Automatic Control Systems installation manual - mounting instructions (chapter 4) for the mounting of a sample changer on a 500 MHz Magnet with Vibration Dampers (figure B.1).



Figure A.1. 500 MHz Magnet

Mounting Instructions

A.2

Preparation

A.2.1

Prepare the light barrier assembly, cabinet and column assembly as described in chapter 4 of this installation manual.

Ensure that you have all of the parts required to mount the B-ACS sample changer to the 500 MHz magnet, as shown in figure B.2.

Connect the adjustable arm assemblies (figure B.2) to the round column part just below the cabinet (figure B.6), and tighten them loosely. (Note: the larger two segment ring is the column end of the assembly).

Figure A.2. Parts Required for Assembly on 500 MHz Magnet

(Viewed from Above)

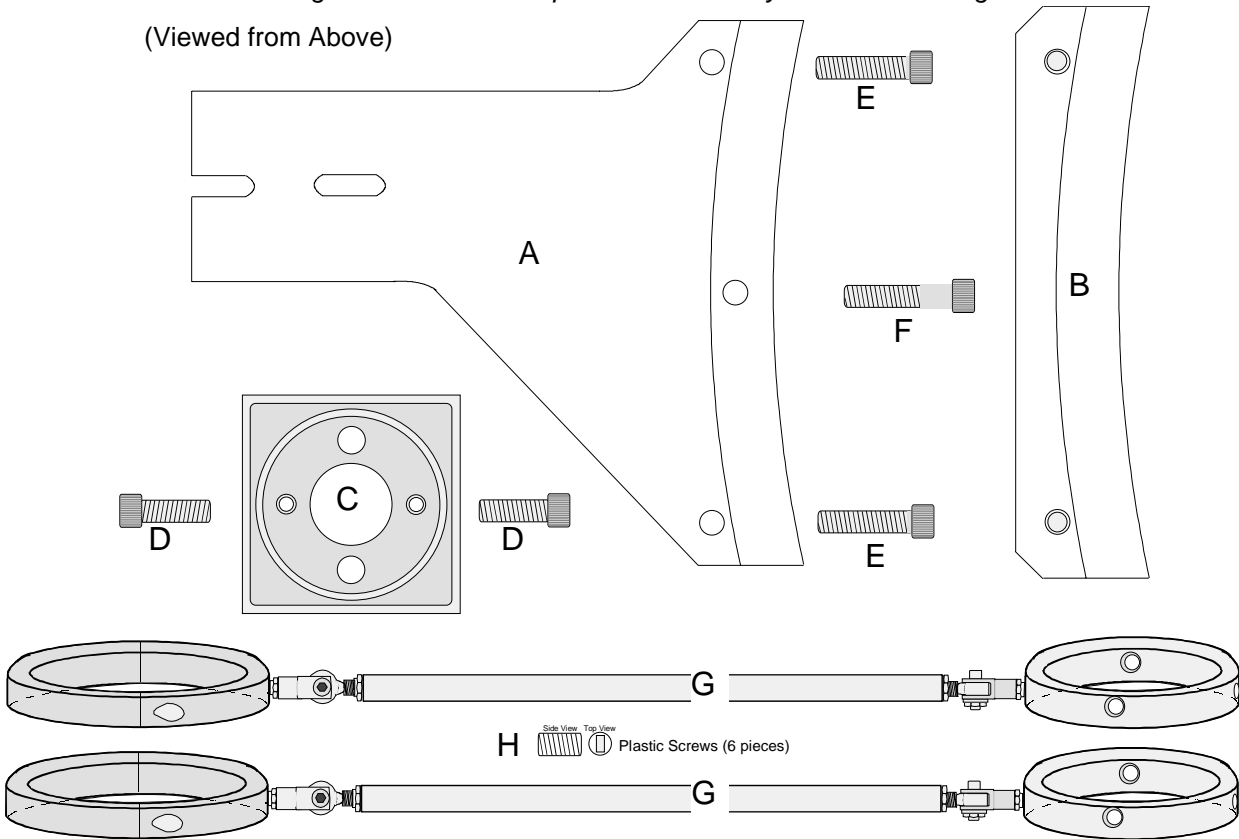

Part Requirements:

Item	Quantity	Description
A	1	Base Plate
B	1	Upper Support Bracket
C	1	Column Support Bracket
D	2	Machine Screws 3.3 cm
E	2	Machine Screws 4.3 cm
F	1	Machine Screw 4.7 cm
G	2	Adjustable Arm Assembly
H	6	Plastic Screw

Mounting the Base Plate

A.2.2

Remove the holding screw from the front of the magnet as shown in figure B.3. Place the base plate under the rim of the magnet and fasten it to the magnet, using the 4.7 cm machine screw (refer to figure B.4). Do not tighten the screw completely, allow some movement for adjustments.

Place the upper support bracket on top of the base plate as shown in figure B.4. Secure it using the two 4.3 cm machine screws. Tighten these two screws and the screw holding the base plate securely.

Mount the column support bracket with the bottom side down (as shown in figure B.4), using the two 3.3 cm machine screws. Tighten the screws hand tight, allowing some free play for later adjustments.

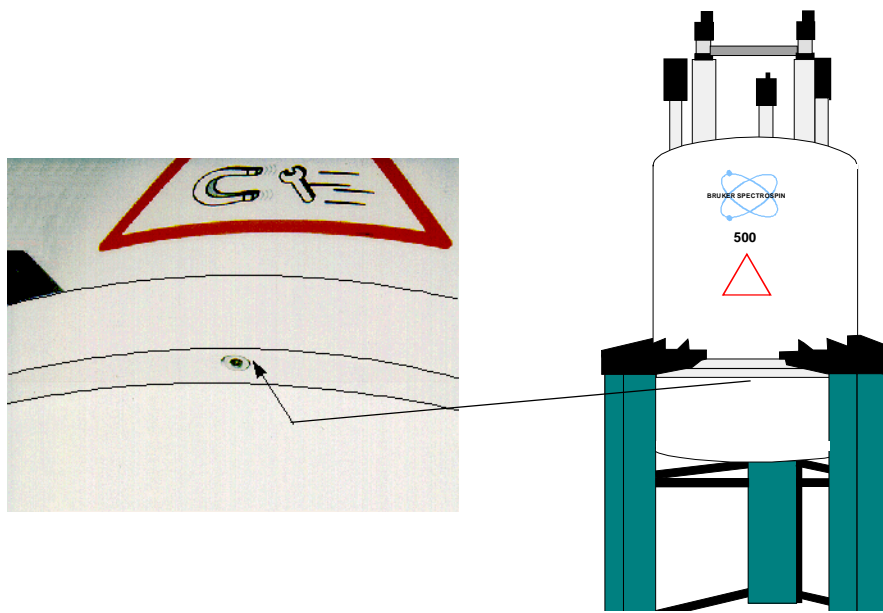

Figure A.3. Holding Screw on the Magnet

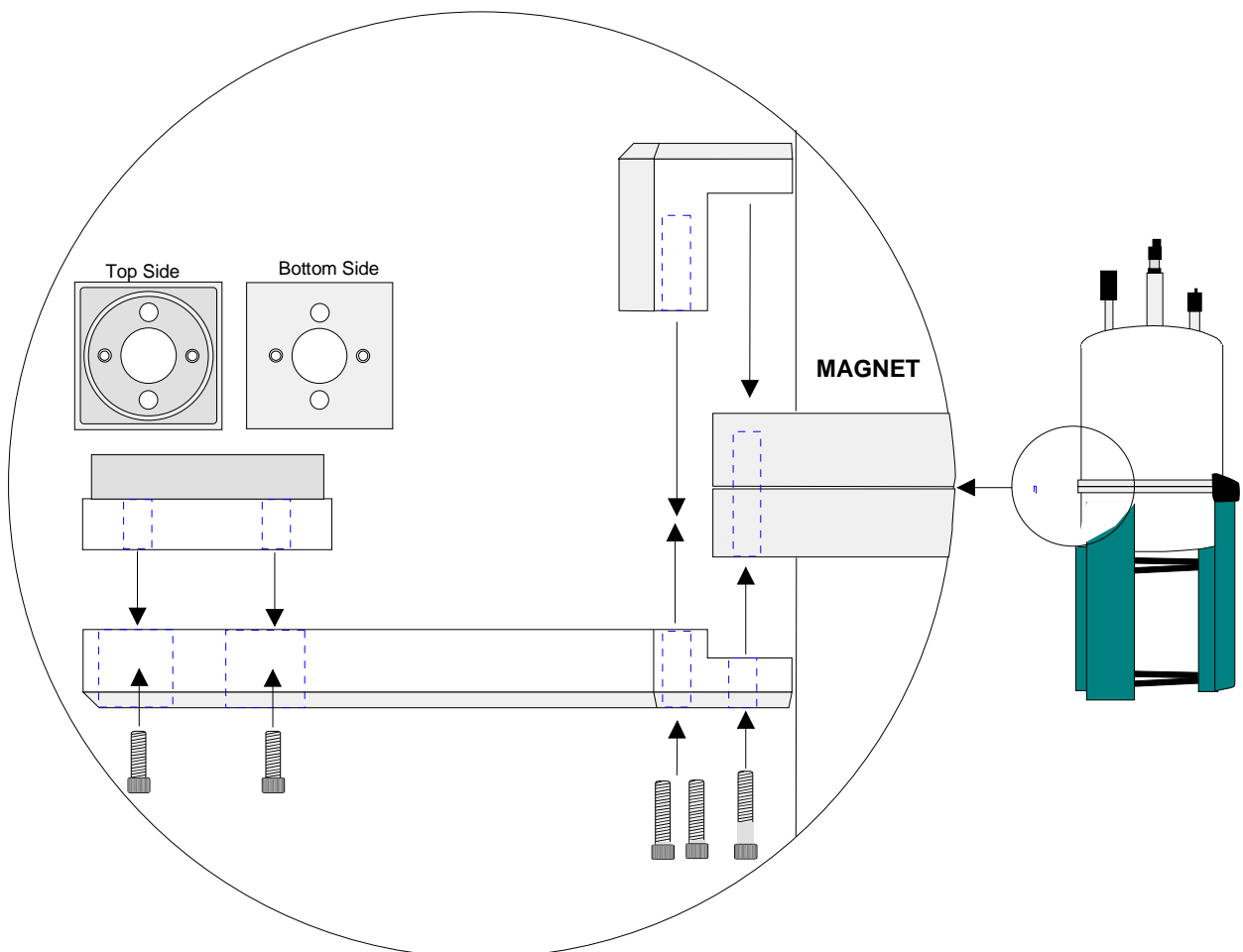

Figure A.4. Mounting the Base Plate and Supports

Place the column assembly with the attached cabinet onto the column support bracket so that the square column piece is perpendicular to the center of the magnet (see the following figure).

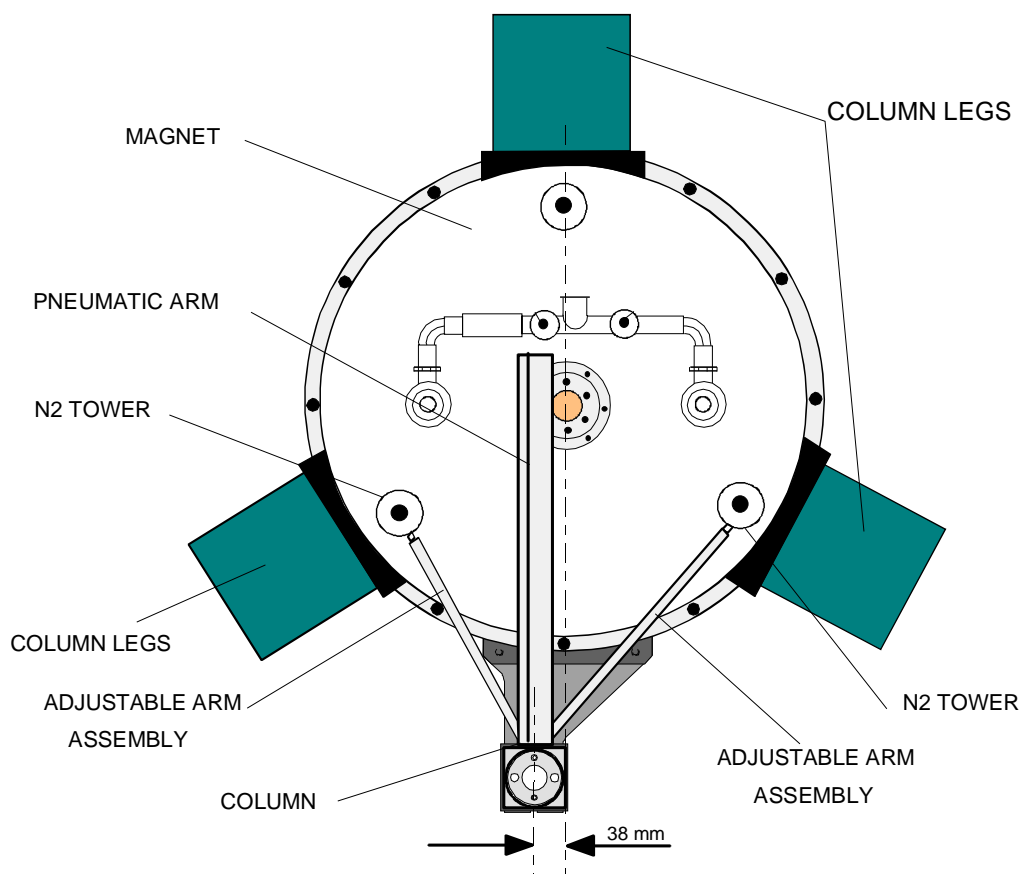

Figure A.5. Top View of the 500 MHz Magnet with Sample Changer

Place the magnet end (the smaller ring) of the adjustable arm assemblies over the N2 towers as shown in figures B.5, B.6 and B.8. Align the arms so they are as horizontally level as possible, ensuring that the arms do not touch the magnet.

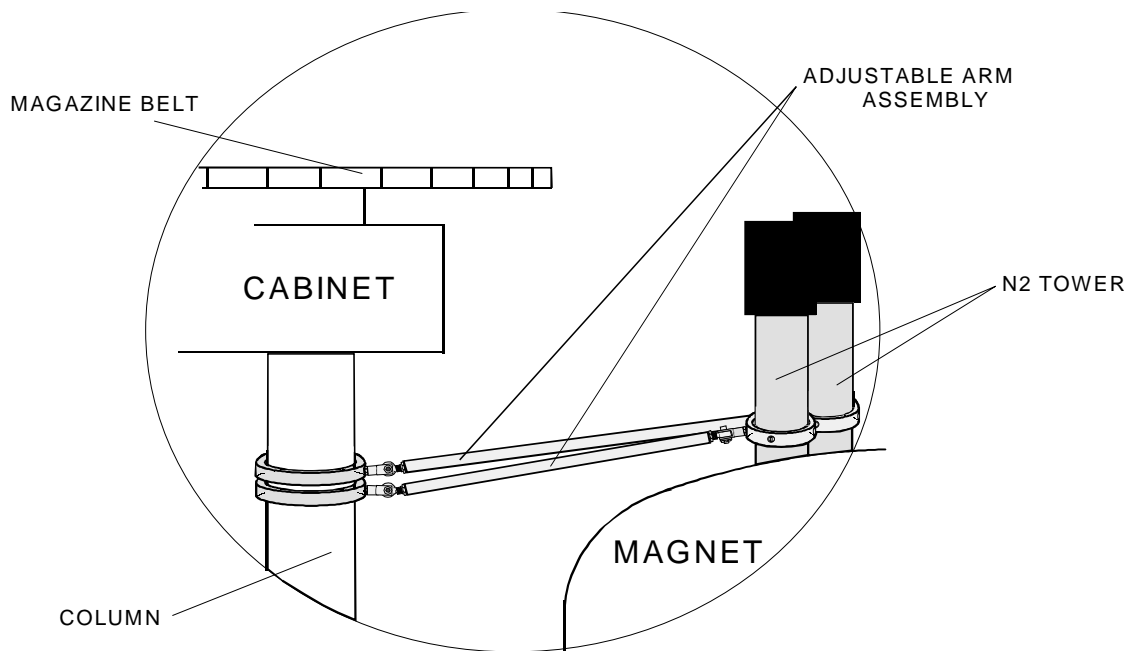

Figure A.6. Base Plate and Adjustable Arm Assembly

Final Adjustments

A.2.4

Move the column assembly until it is approximately horizontally and vertically level by intermittently turning the adjustable arm assembly rods and the column support bracket forwards or backwards (**Figure A.8**). Tighten the adjustable arm assembly (both ends) and the two screws holding the column support bracket.

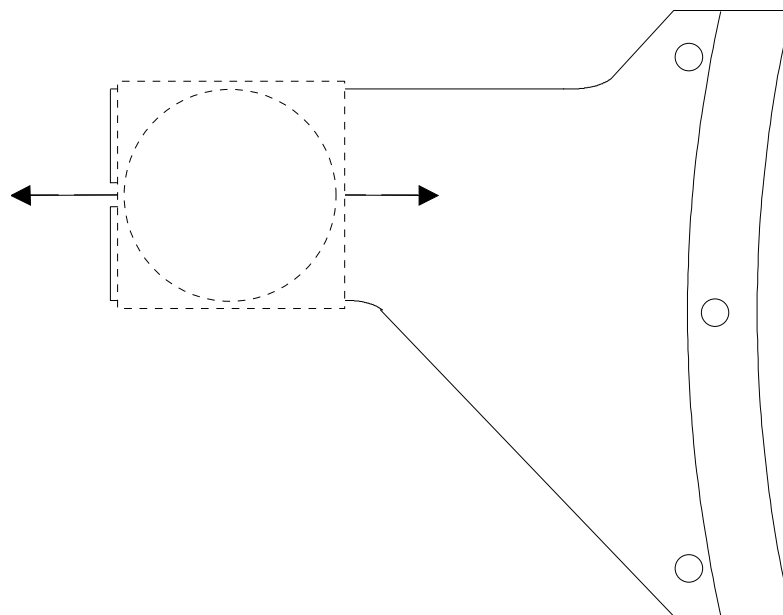
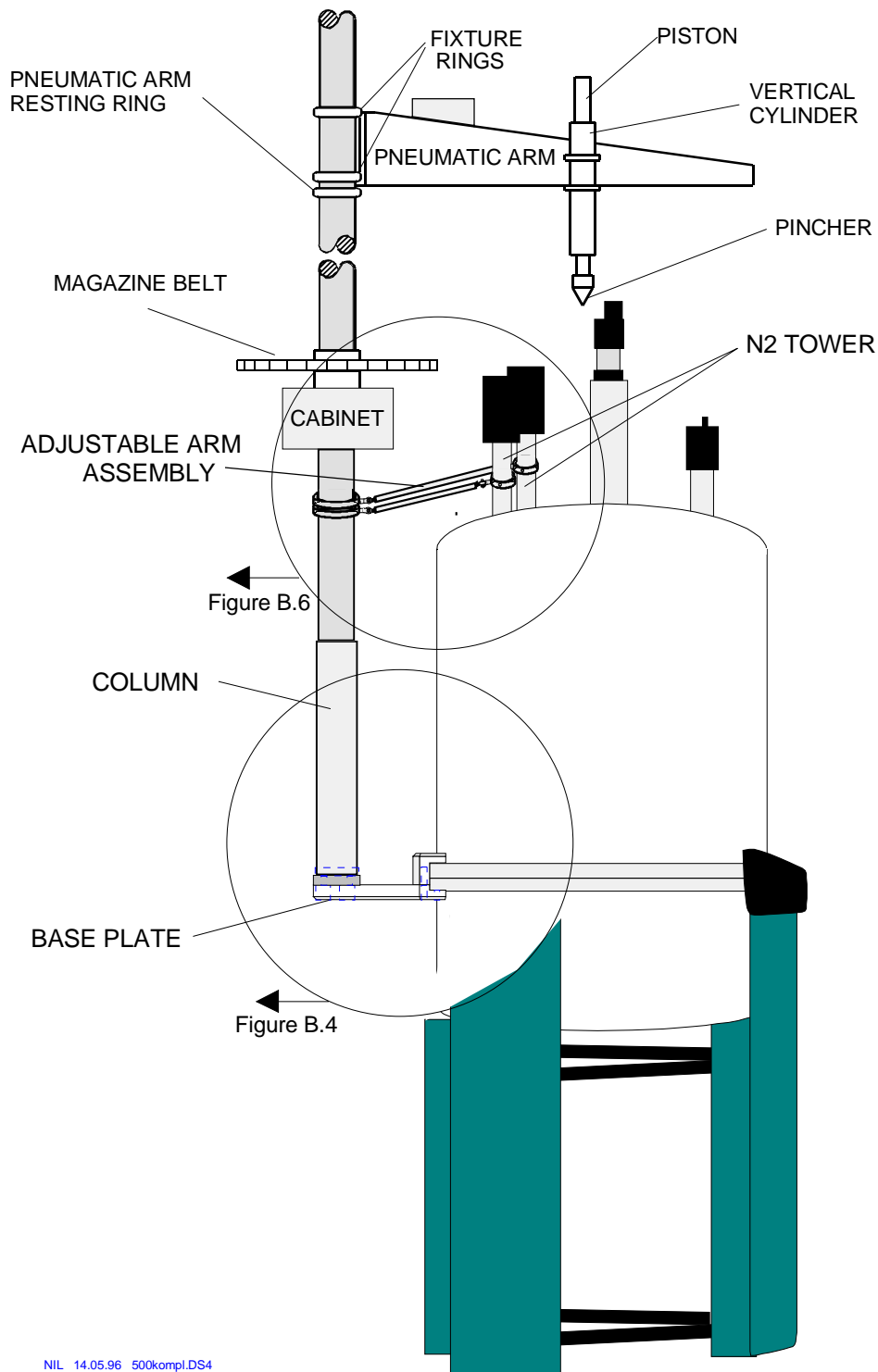

Figure A.7. Adjustment Possibilities for the Column Assembly

Recheck the horizontal and vertical level using a water level. Adjust the adjustable arm assemblies and/or the column support bracket on the base plate as needed (repeat until the column is horizontally and vertically level).

Check once again that all of the screws and the adjustable arm assemblies are tight.



NIL 14.05.96 500kompl.DS4

Figure A.8. Overview of the Sample Changer on a SAG Magnet

Sequence for Mounting & Adjusting B-ACS

B

Sequence for Mounting & Adjusting B-ACS

B.1

Mounting order for the B-ACS (short version for experienced service engineers).

1. Mount the base plate of the magnet as shown in [Figure 3.1.](#)
2. Remove the rear panel of the B-ACS cabinet.
3. Insert the round column into the cabinet.
4. Fix the round column so that the side opening is in the middle of the cabinet and is pointed to the rear side of B-ACS (towards the magnet).
5. If the customer has ordered a sample heater option (refer to the chapter ["Sample Heater Option" on page 139](#)), then place the sliding ring at the round column below the cabinet. Watch the orientation! The rotating element must be on top to prevent the cables from becoming tangled.
6. Insert the clamp cover of square column over the round column. Likewise insert the square clamp over the square column as shown in [Figure 3.6.](#)
7. Pull all the cables from the square column, upwards through the inside of the round column, and out the side opening of the round column, which is now inside the cabinet.
8. Mount the round column inside the square column as follows:
 - a. Measure the distance from the laboratory floor or magnet base plate to the upper surface of the Bruker Sample Transfer (BST). If you are using the old shim system, first mount the light barrier assembly as shown in the section ["Connecting the Light Barrier Assembly" on page 16.](#)
 - b. Insert the round column into the square column. Rotate the square column so that the emergency stop faces the sample changer's front side (B-ACS display is on the front side. If mounting lugs are present for the adjustable arm assembly (see [Figure 3.11.](#)) they should not be oriented towards the magnet).
 - c. Insert the 4 vertical locking mechanisms into the square column (refer to [Figure 3.6.](#)).
 - d. Adjust the height of the cabinet. The cabinet must be 2 cm below the upper surface of the BST (with the light barrier assembly mounted) as shown in [Figure 3.10.](#)

- e. Tighten the 4 vertical locking mechanisms screws.
9. Fasten the square clamp to the top of the square column. Place the clamp cover above the square clamp.
 10. Remove the mounting lugs for the N2-Towers from the upper adjustable arm assembly and mount them to the N2 towers of the magnet. Mount the rest of adjustable arm assembly on the column below the cabinet. The sample changer has a small offset to the left hand side of the base plate that ensures that the horizontal cylinder is centered correctly (refer to **Figure A.7.**).

Before mounting, loosen the locknut and lengthen the adjustable arm assembly by about 3 cm (on the left side) and about 5 cm (on the right side)

11. Place the whole sample changer on the base plate and fasten the adjustable arm assembly to the lugs mounted on the N2-Towers (refer to **Figure 3.8.**).
12. If present, mount the lower adjustable arm assembly to the magnet as shown in **Figure 3.11.**
13. Slide the pneumatic arm resting ring (see **Figure 3.9.**) over the top of the round column piece and let it rest on the top of the cabinet (don't tighten it). The key slot must face upwards.
14. Move the vertical cylinder of the factory mounted horizontal & vertical arm assembly to its outward end position (position above the magnet) and downwards.
15. Place the pneumatic arm assembly over the top of the column, sliding the two fixture rings downwards. Adjust the height, whereas the fingers of the closed pincer are about 2 cm above the upper surface of the BST (including the optionally mounted light barrier assembly when using the old BST's).
16. Move the resting ring upwards and insert the bolt into the key slot. Rotate the resting ring to its left or right end position marked by the bolt. Fasten it in this position.
17. Align the whole B-ACS assembly using the adjustable arm assembly and the elongated hole in the base plate:
 - a. The round column must be absolutely vertical. Check both orientations using a water level!
 - b. The B-ACS is mounted with a small offset to the left hand side to ensure that the pincer is centered correctly above the BST (refer to **Figure A.7.**).
 - c. Tighten all the screws at the base plate and the fixing rings of the horizontal unit EXCEPT the lock nuts at the adjustable arm assembly (which need to stay loose for fine adjustments later on).
18. Remove the black flexible rubber sleeve from the top of the round column. Pull all the cables into the round column. Place the black flexible rubber sleeve back on top of the round column. Connect all the pneumatic hoses and electrical cables to the pneumatics & electronics as shown in the following figures: **Figure 3.9.**, **Figure 3.13.**, **Figure 3.14.**, **Figure 11.2.** and **Figure 11.12.**

Turn the Power on.

19. Check if the horizontal unit is horizontally level using a water level!

20. Start the RS Test or use the manual control buttons on the main control board or on the front panel to switch to manual control mode.
21. Place a dummy sample in the pincer.
22. Make the following fine adjustments:
 - a. Horizontal Unit: Is the sample picked up centrally from the magazine? When not move the horizontal carriage as shown in **Figure 4.5.**
 - b. Place a dummy sample into the pincer above the BST. Is the sample inserted into the BST centrally? When not correct the length of the adjustable arm assemblies. The round column **MUST** remain absolutely vertical!
 - c. Rotate the cabinet. Check the sample insertion into the outer magazine ring.
23. Adjust the lift air needle valve. A dummy sample hovering in the lift air stream must stay still and should not be spinning around. Turn the lift off and on. The sample should not “shoot” out of the BST. The middle part of the spinner must be located as exactly as possible between the middle of the light barrier.
24. Test the lift needle valve setting by letting B-ACS take a sample out of the BST and place it back into the carousel magazine. The sample should fall down into the magazine about 2-3 mm if the vertical cylinder has reached its lower position. Otherwise change the vertical position of the cabinet.
25. Now tighten the adjustable arm assembly lock nuts **carefully** without changing their length.
26. Check points 22-24 once again!
27. Close the rear panel of the cabinet
28. Mount the Sample Down Detection Unit as described in the corresponding manual.
29. Turn on the power for the B-ACS. The sample changer is now ready for use!

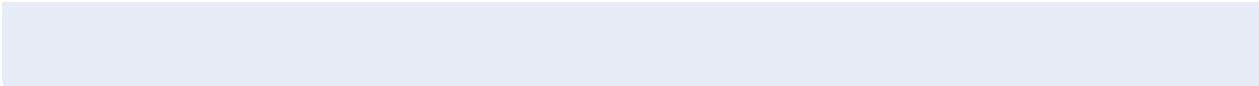

Figures

1	Introduction	11
2	Safety Considerations	13
Figure 2.1.	Extreme Temperature Warning	14
3	Mounting Instructions	15
Figure 3.1.	Location of Adjustable Arm Assemblies	15
Figure 3.2.	Other Anchoring Methods for B-ACS	16
Figure 3.3.	Magnet with BOSS Shim System Already Mounted	17
Figure 3.4.	Light Barrier for the Shim System	17
Figure 3.5.	Front view of the Automatic Sample Changer	18
Figure 3.6.	Column Assembly	20
Figure 3.7.	Adjustable Arm Assembly for Magnets without N2 Tower	21
Figure 3.8.	Adjustable Arm Assembly for Magnets with N2 Tower	21
Figure 3.9.	Arrangement of Pneumatic Arm Assembly	22
Figure 3.10.	Position of the Pneumatic Arm on the Column	23
Figure 3.11.	Adjustable Arm Assembly for Bottom of B-ACS	24
Figure 3.12.	Mounting Sample Changer to Magnet with Vibration Dampers	24
Figure 3.13.	Rear View of the Automatic Sample Changer	25
Figure 3.14.	Partial Front View of Column and Cabinet	26
Figure 3.15.	Pneumatic Connections to Magnet and Console.	27
Figure 3.16.	Cable and Pneumatic Hose Connection Panel	28
4	Settings and Adjustments	31
Figure 4.1.	Cabinet View Showing Main Components	32
Figure 4.2.	Security Switch	33
Figure 4.3.	Sample in Pincher on Top of Shim System	34
Figure 4.4.	Sample in Pincher on Tip of Magazine Belt	36
Figure 4.5.	Mounting the Vertical Cylinder	37
Figure 4.6.	Top View of the Right Wheel and Tension Adjusting Mechanism.	40
Figure 4.7.	Outlet Needle Valves on the Cylinder Supply Connections ...	41
Figure 4.8.	ORIGA Horizontal Cylinder Pneumatic Setting	41
5	Operating Instructions	43
Figure 5.1.	Front Panel of the Automatic Sample Changer	43
6	Software Commands	47
Figure 6.1.	The CCU Extension	48

7	List of Errors	77
8	Special Tools	103
9	Operator Maintenance	105
10	Technical Data	107
11	Circuit Diagrams	109
	Figure 11.1. Circuit Block Diagram	110
	Figure 11.2. Internal Connections Diagram	111
	Figure 11.3. CPU Board Diagram H25	112
	Figure 11.4. CPU Board Diagram H10022	113
	Figure 11.5. LC Display Board H178	114
	Figure 11.6. Mounting the Light Barrier Cabinet on the Cabinet Assembly	115
	Figure 11.7. Rear Side of the Light Barrier Cabinet	116
	Figure 11.8. Location of the Position Switch on the Light Barrier Cabinet	117
	Figure 11.9. Light Barrier Magazine Optic	118
	Figure 11.10. Light Barrier at the Magazine	120
	Figure 11.11. Main Control Board Hex Switches	122
	Figure 11.12. Connections for Operation	123
	Figure 11.13. Power Supply Box Wiring Diagram	124
12	Barcode Reader Option	125
	Figure 12.1. Barcode Reader Units	125
	Figure 12.2. Placing the Barcode Reader Unit on the Cabinet	126
	Figure 12.3. Mounting the Barcode Detection Board	127
	Figure 12.4. Cable Connectors	127
	Figure 12.5. Adjusting the Reflex Sensors	128
	Figure 12.6. Parts Required for Installation of the Barcode Reader	129
	Figure 12.7. Placing the Barcode Reader Unit on the Cabinet	130
	Figure 12.8. Location of the Guide and Drive Wheels	131
	Figure 12.9. Barcode Pressure Reducer with Manometer	132
	Figure 12.10. Location of the Scanner Optics	133
	Figure 12.11. Rear Side of Label Printer	134
	Figure 12.12. Barcode Reader Block Diagram	137
	Figure 12.13. Barcode Adapter Board Component Layout B-ACS 60	138
	Figure 12.14. Barcode Adapter Board Component Layout B-ACS 120	138
13	Sample Heater Option	139
	Figure 13.1. The B-ACS Sample Heater 120C	139
	Figure 13.2. The B-ACS Sample Heater Mounted on the Cabinet Assembly	140
	Figure 13.3. Extreme Temperature Warning	141
	Figure 13.4. B-ACS Sample Heater	143
	Figure 13.5. Test Measure	144

Figure 13.6. Heater Supply (used until Serial No. 34) 145
 Figure 13.7. Heater Supply (after Serial No. 35) 147
 Figure 13.8. Burndy Connector B-ACS Heater Power Supply 148

A 500 MHz and 600 MHz SAG Magnets 151

Figure A.1. 500 MHz Magnet 151
 Figure A.2. Parts Required for Assembly on 500 MHz Magnet 152
 Figure A.3. Holding Screw on the Magnet 153
 Figure A.4. Mounting the Base Plate and Supports 153
 Figure A.5. Top View of the 500 MHz Magnet with Sample Changer 154
 Figure A.6. Base Plate and Adjustable Arm Assembly 155
 Figure A.7. Adjustment Possibilities for the Column Assembly 155
 Figure A.8. Overview of the Sample Changer on a SAG Magnet 156

B Sequence for Mounting & Adjusting B-ACS 157

Tables

1	Introduction	11
2	Safety Considerations	13
3	Mounting Instructions	15
4	Settings and Adjustments	31
5	Operating Instructions	43
6	Software Commands	47
7	List of Errors	77
Table 7.1.	Sensor Signal Table	90
8	Special Tools	103
Table 8.1.	Tools for mounting the Automatic Sample Changer	103
9	Operator Maintenance	105
10	Technical Data	107
Table 10.1.	B-ACS Equipment Identification	107
11	Circuit Diagrams	109
12	Barcode Reader Option	125
Table 12.1.	Serial Interface Switch Positions	135
Table 12.2.	Label Printer Connected to ASPECT and Station	135
Table 12.3.	Label Printer Connected to IBM-PC	135
13	Sample Heater Option	139
Table 13.1.	B-ACS Heater Supply Kit	141
Table 13.2.	Test measure	144
Table 13.3.	H15 connector	146
Table 13.4.	H15+2HA connector	148
Table 13.5.	Burndy Connector B-ACS Heater Power Supply	149

<i>A</i>	<i>500 MHz and 600 MHz SAG Magnets</i>	151
<i>B</i>	<i>Sequence for Mounting & Adjusting B-ACS</i>	157

Index

Numerics

230V main power cable.....	28
230V power cable	28

A

active dampers.....	15
Adapter Boards	134
adjustable arm assemblies.....	15, 20, 35, 38
Adjusting the PK100 parallel	145
Adjusting the PK240.....	147
Air Pressure	132

B

B-ACS SAMPLE HEATER 120C	139
Bar Code Detection Board	129
bar code detection board	127, 131
Bar Code Detection Board Installation	127, 130
Bar Code Detection Cable	126, 129 – 130
bar code length	133
Bar Code Pressure Reducer with Manometer	129
Bar Code Pressure Reducer, Mounting of	131
Bar Code Reader Mounting the Reader Unit on the Cabinet.....	126, 131
Bar Code Reader Unit.....	126, 129 – 131
Bar Code Reader, Adjusting air pressure	132
Bar Code Reader, Adjusting the Scanner Optics.....	133
Bar Code Reader, Centering Samples.....	133
Bar Code Reader, Putting into operation	128, 132
base plate.....	19
belt magazine.....	44
BOSS 1	16, 28
BOSS 2	16, 28
BSMS.....	28

C

Cabinet and Magazine Belt Adjustment	35
cabinet resting ring.....	18
Cable and Pneumatic Connection Panel	28
Cable and Pneumatic Hose Connection Panel	28, 31
carrousel belt.....	128, 132
Channel B	133
column assembly	21
Communication Protocols	134

compressed air supply	26
Connection Panel.....	28
CONT	43
CONTINUE	133
cylindrical collar.....	18
 D	
DC power supply.....	140
DIP switch settings.....	134
dummy sample.....	33
 E	
exhaust outlet.....	40
 F	
Final Setup	41
Fine Adjustment Procedures.....	37
Fitting Samples into the sample magazine	44
fixture rings.....	22
front panel	43
Front Panel Controls	43
 H	
Heater Power Supply Kpl.	141
Heater Supply 2	142
host computer	43
 L	
LCD DISPLAY	43
LCD display	44
Light Barrier Cabinet, Adjustment Procedures.....	116
Light Barrier Cabinet, Mounting on the Magazine	114
light barrier cylinder.....	16
Light Barrier Magazine	140
LISH 5	28
 M	
Magazine Belt, Manual Motion (Control) of.....	45
MAGAZINE MOTION	43
magnet lifting lugs	20
magnetic valves	40
Mains Connection	28
mains connector.....	32
Manometer	129
Mechanical Settings	31

N

needle valve	26
needle valves	40

O

one-way valve	26
Optics, Adjustment of	116
ORIGA horizontal cylinder.....	40
OVERVOLTAGE PROTECTION	147

P

perpendicularity of the column	38
Pin assignment rear panel	148
pincher	23
PK100 Supply Module connectors	146
Pneumatic Arm Adjustment.....	33
pneumatic arm assembly	22
pneumatic arm resting ring.....	22 – 23
pneumatic connector plate	23
pneumatic hose connector	131
pneumatic hoses	25
Position Switch.....	116
Power Supply	142
pressure reducer	131
PWR24 cable	142

R

READY waiting loop.....	44
RESET	43 – 44
RESET button	133
RS232 cable.....	43
RS232 connector	28
RS232C Serial Link.....	121

S

SAMPLE HEATER	139
Sample Heater Connector on PK240 Supply Module	148
Sample Heater electrical characteristics	149
Sample Heater Installation	142
Sample Heater Operating instructions	142
Sample Heater sliding ring	140
Sample Heater Start-up	143
Sample Heater Testconditions	143
Sample Heater, Installation	142
Scanner Optic Unit.....	133
Sensor Connector Assembly.....	25
Serial Interface Switch Position.....	135
Settings at the Magazine.....	39

Settings at the Magnet	38
Shim System	28
shim system	23
Shim Systems	16
SLCB board.....	28
sliding ring (P/N H5886)	142
speed of both the vertical and horizontal cylinder	40
spinner detection reflector	134
square clamp.....	19
Starting the B-ACS 60 or 120.....	44
System Parameters.....	121

T

Testmeasure	144
Testpoints on the Adapter Boards.....	134
TMC legs.....	15

V

Vibration Dampers	22, 24
-------------------------	--------

W

wide bore magnets.....	22
------------------------	----



Notes: