

BLAX2500

RF Power Amplifier 10-130MHz Operating & Service Manual

Version 001

BRUKER

In case of NMR application :

The information in this manual may be altered without notice.

BRUKER accepts no responsibility for actions taken as a result of use of this manual. BRUKER accepts no liability for any mistakes contained in the manual, leading to coincidental damage, whether during installation or operation of the instrument. Unauthorised reproduction of manual contents, without written permission from the publishers, or translation into another language, either in full or in part, is forbidden.

In case of MRI application :

Compliance with its contents is a preliminary condition for correct unit operation as well as for the safety of the patient and the operator.

The manufacturer may not be held responsible for the safety, reliability and specifications of the unit if :

- assembly, extensions, adjustments and repairs are not performed by the manufacturer or by personnel authorised by the manufacturer.
- the electrical installation of the premises does not comply with locally applicable requirements.
- the unit is not used in compliance with the instructions for use.

This manual describes the units as they are at the time of printing.

On request, the manufacturer shall supply circuit diagrams, lists of components, descriptions, calibrating instructions and any other information for use by qualified personnel of the user, in charge of repairing the parts of the unit which have been stated by the manufacturer to be "repairable". Such supply shall in no event constitute permission to modify or repair the units or approval of the same.

All rights reserved for the units, circuits, processes and appellations mentioned herein.

This unit is not designed for any type of use which is not specifically described in this manual. Such use may be hazardous.

This manual was written by

OTT Charles

© March 5, 1999: Bruker SA

Wissembourg, France

Manual P/N: Z31499

DWG-Nr: 1202001

Contents

	Contents	3
	Index	5
1	General information.....	7
1.1	Introduction	7
2	Safety.....	9
2.1	Labels	9
	Dangerous Area	9
	Name Plate	9
3	Installation.....	11
3.1	Initial Inspection	11
	Mechanical Check	11
	Claim for Damage	11
	Reshipment and Repackaging Requirements	11
	Auxiliary Kit	11
3.2	Installation Requirements	12
	Bench Operation	12
	Cooling and Ventilation	12
3.3	Power Requirements	13
3.4	System Check	13
3.5	Initial Turn On Procedure	13
4	BLAX2500 Operation.....	15
4.1	Front Panel	15
	Indicators	15
	Connectors	16
	Interface Connector RS485	16
4.2	Rear Panel	18
	Rear panel supply connector	18
5	Technical description.....	19
5.1	System Overview	19
5.2	Theory of Operation	21
	RF Path	21
	Control Board	22
	SBS Bus Controller	22
	Supply Status Board	22
	Fan Status Board	23

Contents

	Status Led Board	23
6	<i>Specifications</i>	25
6.1	General specifications	25
	<i>Figures</i>	27
	<i>Tables</i>	29

Index

General information

1

Introduction

1.1

The BLAX2500 Pulse Power Amplifier is a broadband linear pulse power amplifier specifically designed for Nuclear Magnetic Resonance and Magnetic Resonance Imaging (NMR/MRI) applications from 0,5 to 3 Teslas Systems.

The BLAX2500 is a class AB linear amplifier with a full 2500 W peak power rating over the frequency range 10 - 130 MHz, and realised by employing N-CHANNEL MOS BROADBAND RF POWER FETs of the latest generation. The unit can provide full power for any combination of pulse width up to 10 ms and duty cycle up to 10 %.

The internal protection circuitry will allow a large power range in the limit of the maximum duty cycle and the maximum pulse width, to maintain a power average of 250 W. For decoupling applications, 100 W CW is also available.

The electronic protection circuitry has been designed to protect against :

- Excessive power output level (overdrive)
- Excessive pulse repetition rate (over duty-cycle protection)
- Excessive pulse duration (over pulse- width)
- More than 50 % reflected RF power (mismatch ≥ 6)

The amplifier is powered by an external switched power supply assembly, housed in a 19" rack cabinet.

Labels

2.1

Labels are provided to alert operating and service personnel to conditions that may cause personal injury or damage to the equipment from misuse or abuse. Please read the labels and understand their meaning.

Dangerous Area

2.1.1

WARNING ! High Voltage.

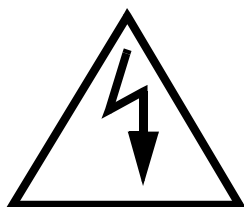

Name Plate

2.1.2

The BLAX2500 can be identified by a name plate at the front panel of the unit which has information as follows :

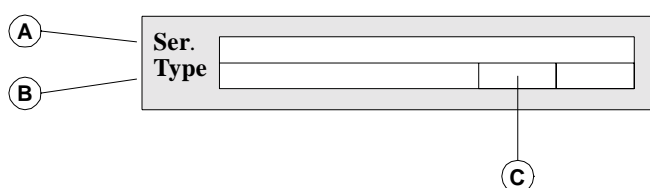

- **(A) Ser.**
This line contains an assembly number which identifies the Part and the Serial number of the product.
- **(B) Type**
This line contains the designation of the product.
- **(C) Revision**
This cell indicates the revision number which identifies the product configuration. The initial revision is 00.

Installation

3

Initial Inspection

3.1

Mechanical Check

3.1.1

If damage of the shipping carton is evident, request the carrier's agent be present when the instrument is unpacked. Check the equipment for damage and inspect the cabinet and panel surfaces for dents and scratches.

Claim for Damage

3.1.2

If the unit is mechanically damaged or fails to meet specifications upon receipt, notify BRUKER or our representative immediately. Retain the shipping carton and packing material for the carriers inspection as well as for subsequent use in returning the unit if necessary.

Reshipment and Repackaging Requirements

3.1.3

Whenever possible, the original carton and packing material should be used for reshipment. If the original packing material is not available, wrap the instrument in heavy paper or plastic. Use a strong shipping container. If a cardboard is used, it should be at least 200 lbs. test material.

Use shock absorbing material around all sides of the instrument to provide a firm cushion and to prevent movement inside the container wall on each side. Protect the front panel by means of cardboard spacers inserted between the front panel and the shipping carton. Make sure that the instrument cannot move in the container during shipping. Seal the carton with a good grade of shipping tape and mark the container :

" FRAGILE ELECTRONIC INSTRUMENT."

Auxiliary Kit

3.1.4

The BLAX2500 is shipped with an accessories kit containing following items :

- Manual
- Line Cord
- Switched Power Supply in separate carton

The BLAX2500 P/N : W1345051 with the POWER SUPPLY P/N : W1345013 is commercialised under the BRUKER Part Number P/N : W1303352

Installation

Installation Requirements

3.2

No special precautions are necessary. Mount the equipment in an area which is relatively free of vibration, and has sufficient room for cable connections.

Bench Operation

3.2.1

The units can be placed onto a secure flat surface.

Cooling and Ventilation

3.2.2

No specific cooling or ventilation is required. It should, however, be in an environment which conforms the 0° - 50 °C (32 °F - 158 °F) specification, and in an area that does not obstruct the free flow into and out of the unit.

Power Requirements**3.3**

The BLAX2500 is designed to be powered by means of an additional switched power supply (BRUKER Part Number P/N : W1345013).

The connection to this power supply is realised via a 500mm cable fitted with a 15 pins DIN 41612-H ERNI female connector, and coming out from the rear panel of the amplifier.

This switched power supply provides all the voltages necessary to the BLAX2500. (5 x 32 V ; + 15 V ; - 15 V ; + 5 V ; GND)

System Check**3.4**

Before applying power for the first time the following items should be checked :

- The AC input voltage from the Power Supply must be compatible with 176 to 264 VAC range.
- An external blanking (gating) pulse must be supplied to the amplifier in order for the unit to function. Ensure that this pulse is of proper level and logic polarity.
- The BLAX2500 has a nominal input level of + 4 dBm. Ensure that the system drivers are operating at these levels.

Initial Turn On Procedure**3.5**

The following list describes how to turn on the BLAX2500 and what should be seen as this occurs.

Before starting this procedure, make sure that you have properly followed instructions in the "System Check" Section.

1. Connect the amplifier to the power supply and turn the circuit breaker, to ON.
2. Observe the indicators on the front panel of the power supply :
 - The five channels + 28 V ON LEDS will illuminate
 - The + 15 V; - 15 V, and + 5 V ON LEDS will illuminate
3. Observe the indicators on the front panel of the amplifier :
 - The + 28 V, + 15 V, - 15 V, + 5 V ON LEDS will illuminate
4. System is now fully operational

BLAX2500 Operation

4

Front Panel

4.1

The BLAX2500 front panel is provided with 12 indicators for status monitoring, 3 connectors, and 1 interface connector.

Indicators

4.1.1

Normal operation is indicated when following LED's are on :

+ 28 V ON	Indicates that the 5 x 32 V supplies are applied
+ 15 V ON	Indicates that the + 15 V supply is applied
- 15 V ON	Indicates that the - 15 V supply is applied
+ 5 V ON	Indicates that the + 5 V supply is applied

following LED's,

Overdrive	Indicates when the power limit has been reached
Duty Cycle	Indicates when the duty cycle limit has been reached
Pulse Width	Indicates when the pulse width limit has been reached
Mismatch	Indicates when the max. reflected power limit has been reached
RF Power FLT	Lights ON when one of the above limits has been reached
Overheat	Indicates that the thermistor located on the RF heat-sink has sensed excessive heatsink temperature. All gating is removed from the amplifier until the unit cools. The function is self-resetting and no maintenance is needed
X ON	Lights on when RF Power is present
Multipulse ON	Indicates when the unit is in Multipulse Mode. If duty cycle limit is reached, duty cycle LED lights ON, but not the RF Power Fault LED, and the unit still being gated.

X in	RF in SMA type connector (female) Nominal + 4 dBm drive to the BLAX2500 to deliver full power
X2500	RF OUT N type connector (female)
BLANKING	BNC type connector (female). TTL logic, 5 V = blanking ON, 0 V = blanking OFF When BLANKING signal is at TTL level high (5 V), no gating is applied to the amplifier stages, and no RF Power is possible. When BLANKING signal is at TTL level low (0 V), the amplifier stages are gated, and RF Power is possible

The Control I/O interface connection is a 15 pin, D shape sub-miniature type connector mounted on the SBS BUS Controller.

SBS BUS = Serial Bruker Spectrospin Bus

The next table shows the pinout of the master and slave connector.

Pin 1	Shield
Pin 2	Transmit data line +
Pin 3	Wake up line /WUP
Pin 4	Receive data line +
Pin 5	NC
Pin 6	GND
Pin 7	GND
Pin 8	GND
Pin 9	Transmit data line -
Pin 10	NC
Pin 11	Receive data line -
Pin 12	NC
Pin 13	VRS (+ 12 V)
Pin 14	VRS (+ 12 V)
Pin 15	VRS (+ 12 V)

Figure 4.1. BLAX2500 Front Panel

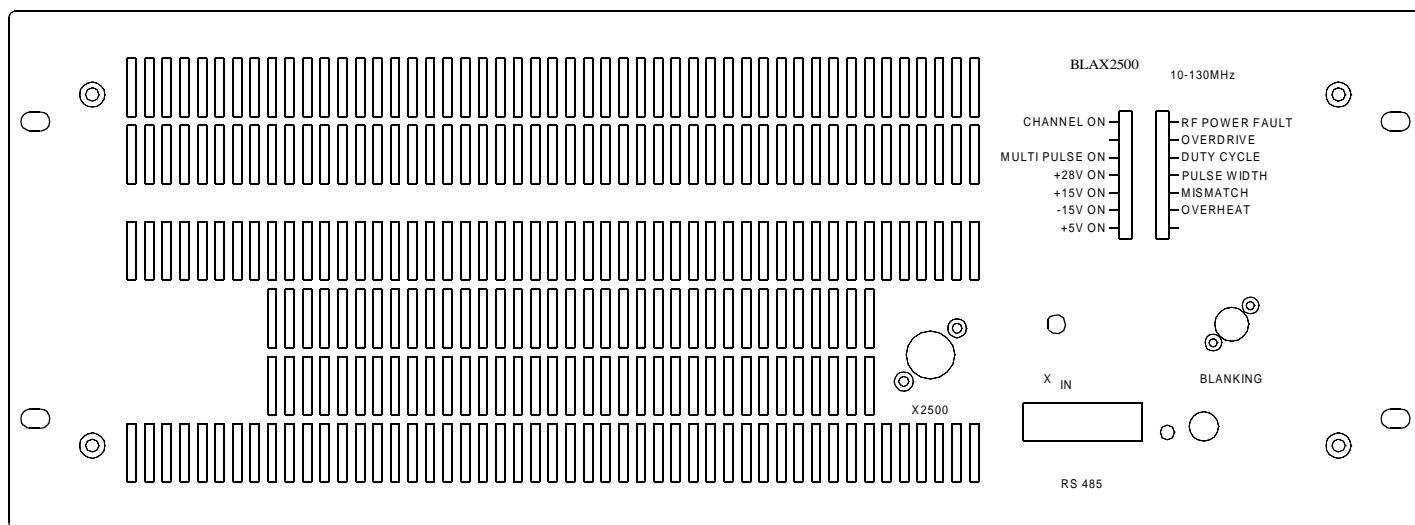

Rear Panel

4.2

The rear Panel of the BLAX2500 Amplifier is free of elements in exception of a 500mm cable fitted with a 15 pin DIN 41612-H ERNI female connector, coming out from the rear panel of the amplifier.

Rear panel supply connector

4.2.1

Table 4.1. DIN 41612-H ERNI Pin assignment

Pin z4	+ 5 V
Pin z8	+ 15 V
Pin z12	- 15 V
Pin z16	+ 32 V
Pin z20	+ 32 V
Pin z24	+ 32 V
Pin z28	+ 32 V
Pin z32	+ 32 V
Pin d6	not connected
Pin d10	DGND
Pin d14	PGND
Pin d18	PGND
Pin d22	PGND
Pin d26	PGND
Pin d30	PGND



Note

DGND = Digital Ground for ± 15 V and + 5 V

PGND = Power Ground for 5 x 32 V

Technical description

5

System Overview

5.1

The BLAX2500 amplifier requires the additional Bruker Power Supply P/N : W1345013, to provide a nominal 66 dB of class AB linear gain in the 10 - 130 MHz frequency range.

The RF section of the system consists of a linear module BLMX2500 mounted around a single, self-contained Push and Pull fan assemblies, heatsink.

A linear class A / AB driver using switches and bias voltage gatings, delivers the RF input power to the four Power Amplifiers, through a Power Splitter/Combiner acting as a 4 ways in-phase splitter.

The driver is located on the bottom of the heatsink assembly, and the power splitter on the lateral left side.

Four class AB power amplifiers, located on the top of the heatsink are combined by mean of a Power Splitter/combiner acting as a 4 ways in-phase Combiner located on the lateral right side of the heatsink.

The output of the combiner is connected to a bi-directional Coupler mounted on the front panel of the amplifier.

The entire system is tied together by the control board and the SBS bus Controller processing information from the amplifier, providing protection from excessive peak power ; duty cycle and pulse width for average power; maximum reflected power ; and heatsink overtemperature.

The peak power protection (overdrive), maximum duty cycle and pulse width, as the maximum reflected power protection (mismatch) can be disabled by jumpers.

Circuits such, Fan Status board, Supply Status board and LED's Status board, completes the amplifier assembly.

Technical description

Figure 5.1. BLAX2500 System Block Diagram

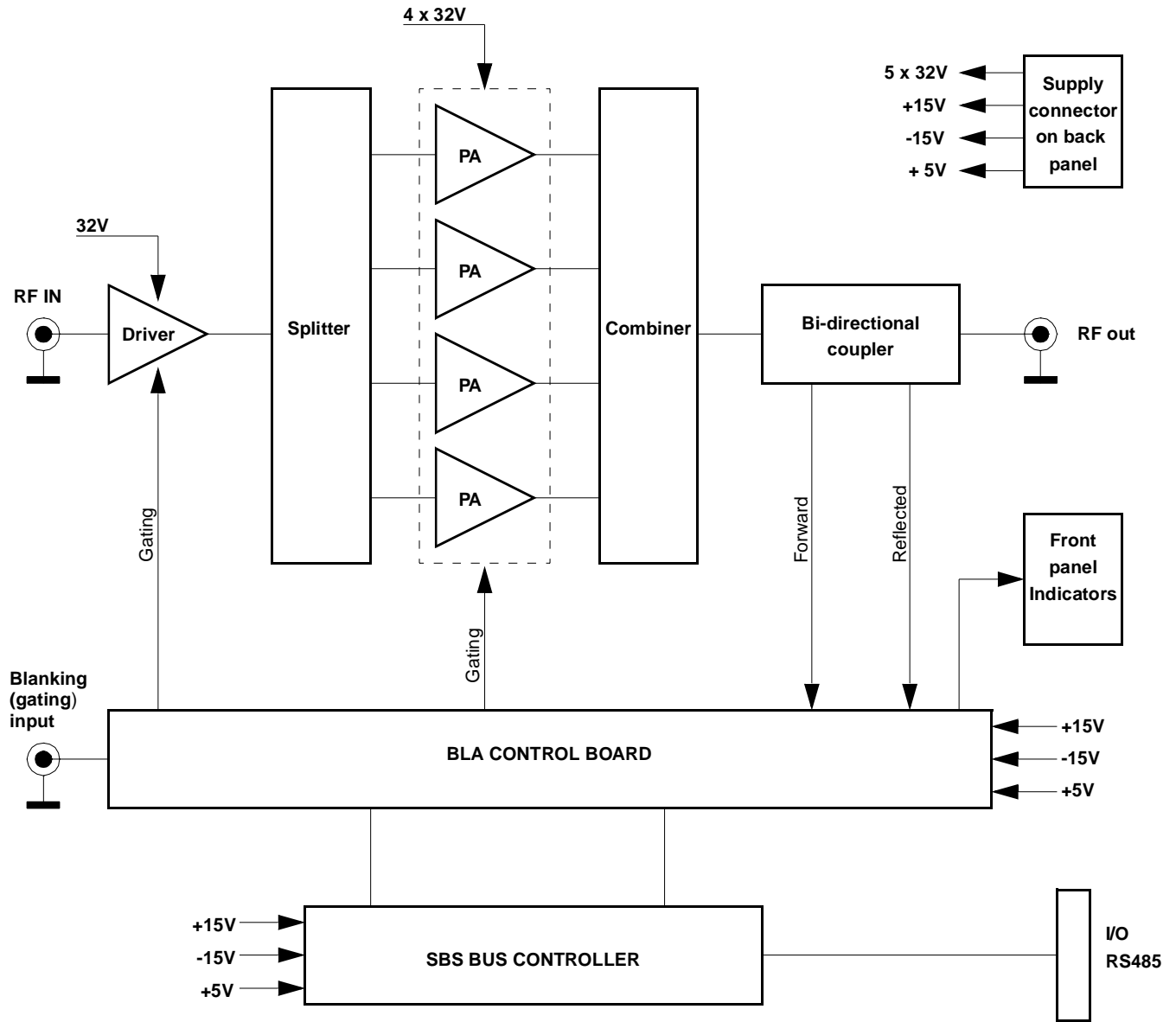

Theory of Operation**5.2**

RF Path**5.2.1**

The BLAX2500 amplifier consists of a Class A/AB driver amplifier and a Class AB power amplifier. A nominal input power level of + 4 dBm produces a rated linear output power of 2000 W peak for 10 % duty cycle at 10 ms pulse width maximum. The unit is also capable of longer pulses for lower average power, up to CW at 100 W.

RF Driver

In the first section of this driver, the input RF signal is fed through an 3 dB attenuator to a hybrid amplifier followed, via an AsGa RF Switch, by a Class A FET amplifier, to built a nominal 23 dB gain block.

This section requires a control board conditioned gating signal to control the operation of the switching element.

The second section of the driver consists in a dual Push-Pull configuration driven by Class A amplifiers at the input, and with Class AB amplifiers at the output. The output amplifiers requires a control board conditioned gating signal to control the bias voltage on the gates of the FETs. The input- output gain of this section is at nominal 27 dB.

The entire RF driver has a nominal 50 dB of gain, and is capable of developing as much as 250 W linear power, and operates off + 32 VDC.

RF Splitter

The RF Splitter on the left side of the BLMX2500 acts as an 4 ways in-phase splitter between the output of the RF driver and the inputs of the 4 power amplifiers PA. All the wiring around this splitter are made with 50R coaxial cables mounted on SMA connectors.

RF Power Amplifier

Each of the four PA includes two FET transistors pairs mounted on a single flange. The circuitry around each transistor pair consists of complementary input and output transformers and baluns and operates the devices in push-pull. The four PA requires a control board conditioned gating signal in order to control the bias gate voltage on the gates of the FETs.

The four PA operates off + 32 VDC and are followed by an in-phase combiner.

RF Combiner

The RF Combiner on the right side of the BLMX2500 acts as an 4 ways in-phase combiner between the outputs of the four PA and the input of the bi-directional coupler mounted on the front panel of the BLAX2500 amplifier. All wiring around this combiner are made with 50R coaxial cables mounted on SMA and N connectors.

RF Coupler

The bi-directional coupler on the front panel provides an approximate 1 V peak DC signal for full output power from the envelope.

The bi-directional coupler also provides peak DC signal for reflected power.

Both signals, forward and reflected, are analysed by the control board for monitoring and protection setting.

Control Board

5.2.2

The BLA Control Board consists of circuitry to monitor the output characteristics of the amplifier as determined from the DC peak detections from the bi-directional coupler, and to condition the input blanking (gating) signal and deliver it to the above mentioned RF Paths.

The monitoring circuitry also serves to process the information from the detections and protect the amplifier from overstress in peak power, average power versus duty cycle and pulse width, so as reflected power. These four functions can be defeated using Jumpers JP1, JP3, JP2 and JP4.

The control board also monitors the RF Path heatsink temperature to protect against thermal overstress, this function can not be defeated.

Information from supply and fan status board also being analysed by the control board.

If one of the above overstresses, or faults on power supply or fans, appears, the gating signal is disabled, and the status led board on the front panel displays the fault.

SBS Bus Controller

5.2.3

The SBS Bus Controller, via the RS485 connector, could read all the information given by the control board as described before, read information about forward and reflected power, information of identifications of the amplifier (Bruker Board Identification System = BBIS).

The SBS Bus controller, via the RS485 connector, also could minimize absolute ratings for pulse width, duty cycle and peak power limitations.

⇒ **Warning: the operating of the SBS Bus Controller needs the exploitation of a Spectrometer Management Software such as BRUKER XWIN - NMR in addition of the ACB (Amplifier Control Board)**

Supply Status Board

5.2.4

This board gives the information of the status of the power supply.

A defect on one or more of the supplies is read by the control board, and in case of, the gating signal is disabled while the defect is visualized on the front panel led display.

Fan Status Board

5.2.5

The fan status board gives information of the status of the two push and pull fan assemblies. A defect on the fans is read by the control board, the gating signal is disabled, and the "overheat" led of the front panel Status led display lights ON.

Status Led Board

5.2.6

The Status Led Board, on the front panel of the amplifier, displays overstress functions, supplies status, and so on, as described in **"Front Panel" on page 15** and **"Control Board" on page 22**

Specifications

6

General specifications

6.1

Table 6.1. BLAX2500 Specifications

Frequency range	10 - 130 MHz
Linear Gain	66 dB typical
Gain Flatness	± 3 dB
Peak Pulse Power	2500 W
CW Power (limited)	100 W max.
Linear Output Power	2000 W @ 1 dB Comp. typical
Linearity	± 1 dB to 2000 W
Amplifier biasing	Class AB Operation
Input/output Impedance	50 Ohms
RF Rise Time	< 200 ns, 10 - 90 % peak power
RF Fall Time	< 50 ns, 90 - 10 % peak power
Blanking Delay Time	< 1 microsecond typ.
Output Noise Power	< - 101 dBm / Hz unblanked Thermal Noise (- 174 dBm / Hz) blanked
Pulse Width (limited)	10 ms @ 2000 W (up CW at 100 W)
Duty Cycle (limited)	10% @ 2000 W (up to 100 % at 100 W)
Amplitude Droop	< 6 % @ 2000 W for 5 ms pulse width
Phase Variation	< 5 degrees for 10 ms pulse width
Constant Internal Protection	Supplies faults & Overtemperature
Defeatable Internal Protection	Forward Power : peak & CW power pulse width duty cycle Reflected Power : peak & CW power
Front Panel Indicators	Amplifier Status Led Board
Front Panel Interfaces	I/O 15-pin subminiature type D connector Additional blanking input BNC connector

Specifications

Table 6.1. BLAX2500 Specifications

Rear Panel Interface	15 - pin DIN 41612-H ERNI female connector (power supply connection)
Cooling System	Forced- air cooling (from front to rear)
Size	7" H x 19" rack cabinet x 23" D (17,8 x 48,3 x 58 cm)
Weight	29 kg
Supply	<p>Additional 176-264 VAC single phase switched power supply Bruker part number W1345013 var.10, delivers :</p> <p>5 x + 32 V / 40 A pulse current 1 x ± 15V /1,5 A, 1 x 5 V / 5 A on the rear panel mounted 15-pin DIN 41612-H ERNI connector.</p> <p>A front panel circuit breaker turns the AC Line ON/OFF A status led board, on the front panel, indicates the power supplies condition</p> <p>Size : 5",25 H x 19" rack cabinet x 20",5 D (13,35 x 48,3 x 52 cm)</p> <p>Weight : 21,5 kg</p>

Figures

1	General information	7
2	Safety	9
3	Installation	11
4	BLAX2500 Operation	15
	Figure 4.1. BLAX2500 Front Panel	17
5	Technical description	19
	Figure 5.1. BLAX2500 System Block Diagram	20
6	Specifications	25

Tables

1	General information	7
2	Safety	9
3	Installation	11
4	BLAX2500 Operation	15
Table 4.1.	DIN 41612-H ERNI Pin assignement	18
5	Technical description	19
6	Specifications	25
Table 6.1.	BLAX2500 Specifications	25

