

BSMS/2

**BSMS/2 Mainframe
Technical Manual**

Version 001

Bruker

The information in this manual may be altered without notice.

BRUKER accepts no responsibility for actions taken as a result of use of this manual. BRUKER accepts no liability for any mistakes contained in the manual, leading to coincidental damage, whether during installation or operation of the instrument. Unauthorised reproduction of manual contents, without written permission from the publishers, or translation into another language, either in full or in part, is forbidden.

This manual was written by

Robert Schmid

© December 1999: Bruker AG

CH-8117 Faellanden

P/N: Z31476

DWG-Nr: 1179 001

Contents

1	General Description	5
1.1	Introduction	5
1.2	Caution	5
1.3	Troubleshooting	5
2	BSMS/2 Chassis and Buses	7
2.1	Introduction	7
2.2	Installation	8
2.3	VMEBus and USERBus	9
2.4	Technical Data	10
3	Power Supply Modules	11
3.1	Introduction	11
3.2	Installation	14
3.3	Troubleshooting	16
3.4	Replacement of a Power Supply Board	17
3.5	Fuses	19
3.6	Technical Data	21
4	Central Processing Board CPU	23
4.1	Introduction	23
4.2	Installation	25
4.3	CPU Controller Section	25
4.4	CPU Peripheral Section	25
4.5	Technical Data	27
5	BSMS Keyboard KBC	29
5.1	Introduction	29
5.2	Installation	33
5.3	Keyboard Controller Board	33
5.4	Keyboard Display Board	33
5.5	Technical Data	34
6	Buses and Wiring	35
6.1	Line Modul (DC-Fan)	35
6.2	Chassis wiring	36
6.3	User Bus wiring	37
7	BVT	43
7.1	BVT and BVT-Supply	43
7.2	Assembling Instructions	43
8	Schemata	47
8.1	Power supply PSB1 place plan	47

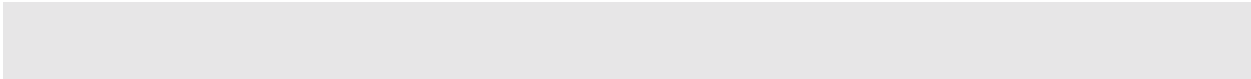

8.2	Power Supply PSB2 place plan	48
8.3	Variant Scheme PSB1 / PSB2	49

General Description

Introduction

1.1

This manual describes the basic system of the BSMS/2 (**B**ruker **S**mart **M**agnet control **S**ystem). The mainframe is a modular system providing slots for functional boards to be plugged in.

The BSMS consists of the following hardware:

1. One chassis with VME- and User-Bus and line module.
2. Two power supply modules.
3. One CPU.
4. One BSMS keyboard (optional).
5. Optional BSMS/2 function boards (e.g., SCB, SLCB,...).

The chassis and buses, power supply modules, CPU, and keyboard are discussed in this manual. The optional BSMS/2 function boards are discussed in additional manuals (e.g., Shim Manual, Sample and Level Manual,...).

Caution

1.2

When turning on the mains switch, the load can cause an excessive start-up current, which saturates the transformer. The primary current will then exceed the fuse value. To prevent this from happening, a negative temperature coefficient resistor (NTC) is introduced in the primary path. The NTC limits the primary current in the start-up phase, but once the unit is in the normal “on” condition, the NTC is warmed up and does not limit the current.

N.B.: Turning the mains switch off and on repeatedly will blow the mains fuse.

Troubleshooting

1.3

All voltages can be checked via the corresponding LED's on the front of the boards, visible from the front of the BSMS/2 chassis (see Corresponding operation indicator LED's on page 20). Note, however, that the LED's only indicate whether power is present or not. For troubleshooting the power supply modules please see Troubleshooting on page 16.

An error on the CPU or BSMS keyboard is indicated by an error message on the BSMS keyboard and by the error LED on the CPU. The error message has the format: *E: “Error number” CPU_ or KBC_ “Error Text” press ‘STD BY’*. For example, *E:1 KBC_ RS timeout. press ‘STD BY’*.

General Description

The following steps may be helpful in troubleshooting such an error:

1. Refer to the installation guide and verify that the installation was done correctly.
2. Check the power supplies to verify that all the power LED's (green) are lit. The ready LED on the CPU should either be lit or blinking. The ready LED's on the BSMS/2 function boards should be lit. If this is not the case check the power supply modules (see Troubleshooting on page 16).
3. Start the BSMS/2 Service Tool (*[bsms]* in UNIX).
4. In the service tool submenus *[6] 'board functions CPU...'* and *[C] 'board functions Keyboard...'* there are functions for debugging the CPU and keyboard, respectively.

BSMS/2 Chassis and Buses 2

Introduction

2.1

The BSMS/2 (Bruker Smart Magnet control System / 2) chassis consists of two 19"-racks called front - and back rack. These are shown in Figure 1. The front rack has 16 slots (shown in Figure 2) for boards the size of extended Eurocards. These boards are plugged on to the backplane, which contains two bus systems: a standard VMEBus and a dedicated USERBus (shown in Figure 3). The front rack can house 14 boards with VME-Bus interfaces and 2 boards with USER-Bus connections only. The back rack houses the power supplies and the pneumatic module.

Above the front rack there is the line module which contains:

1. The mains switch with line filter and fuses.
2. Five fans to actively cool the BSMS/2.

Figure 1: Front and Back Racks in the BSMS/2

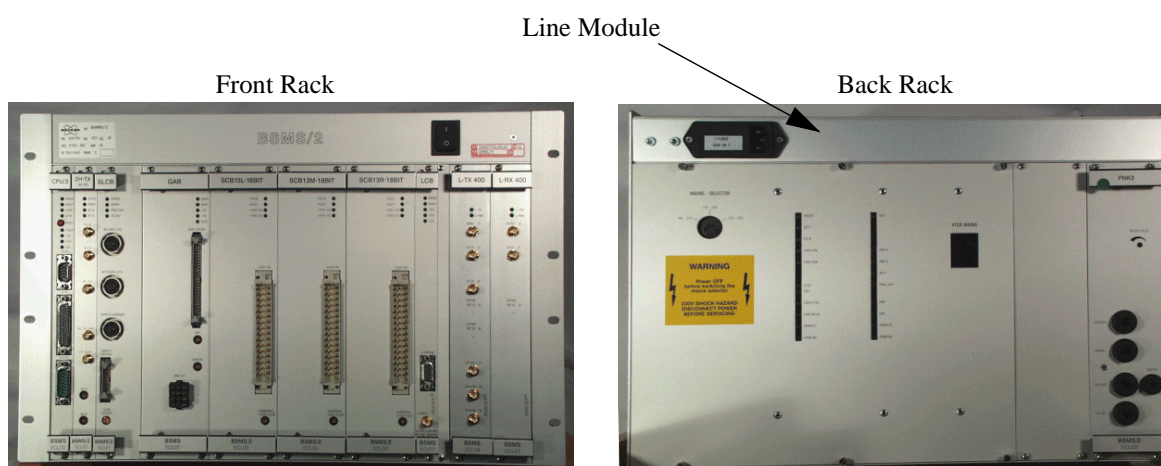

BSMS/2 Chassis and Buses

Figure 2: Slots in the BSMS/2 (Front View)

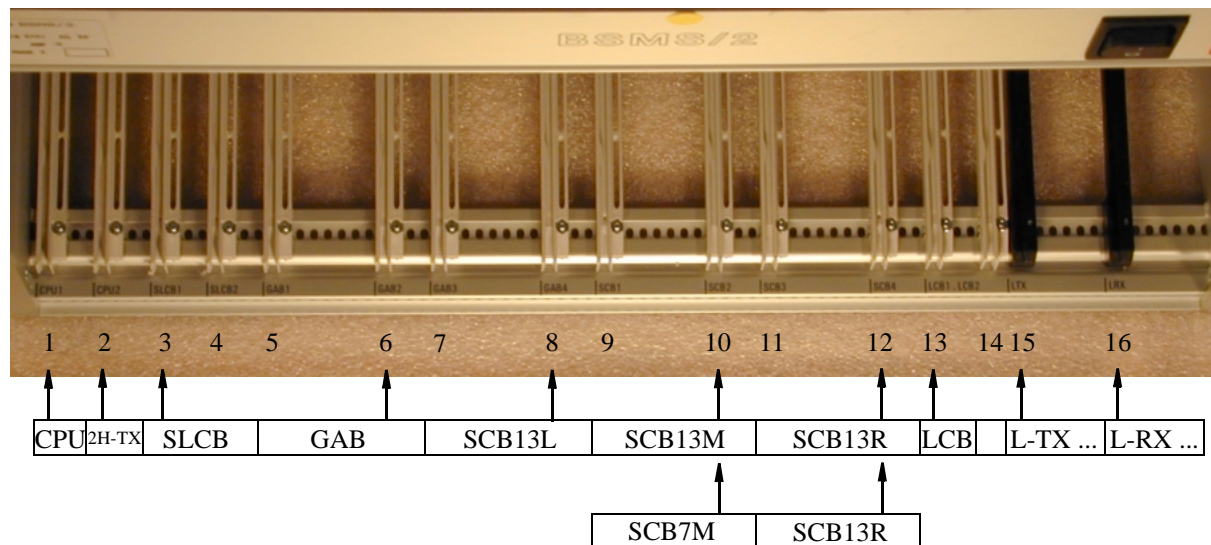

Installation

2.2

There are no special requirements for installation.

Figure 3: Backplane of the BSMS/2 (Front View)

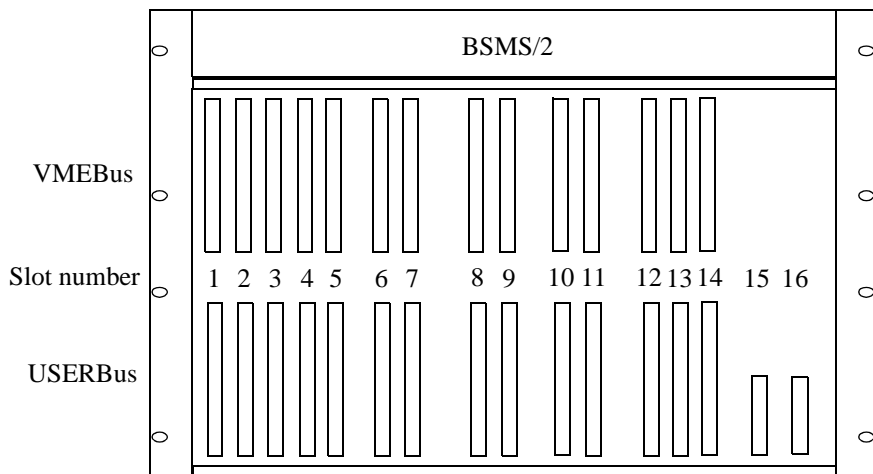

VMEBus

2.3.1

The VMEBus is a 14 slot A16/A24 D16 board corresponding to the VME standard.

USERBus

2.3.2

The USERBus is designed to route all function specific signals and power supplies to the appropriate boards or modules. It contains the frame ground point of the BSMS. The DGND, AGND and GND24 are connected via an inductor (L1) to the frame ground (for DGND, AGND, and GND24, see also Overview of the Power Supplies (Part One) on page 12).

BSMS/2 Chassis and Buses

Technical Data

2.4

Table 1. Technical Data of the BSMS/2 Chassis

BSMS/2 Chassis				
General	Height	310	mm	Dimensions for the chassis.
	Width	485	mm	
	Depth	482	mm	
	Weight	32	kg	For chassis equipped with 1×CPU, 1×SLCB, 2×SCB, 1×LCB, 1×L-TX, 1×L-RX, PSB1, PSB2 and 1×PNK - module.
Front Rack	Board height	233.35	mm	
	Board length	220	mm	
Back Rack	Board height	277.8	mm	
	Board length	160	mm	

Table 2. Technical Data of the Line Module

Line Module			
Mains Fuse	5	A	time lag

Mains - Selector



Power Supply Modules

Introduction

3.1

The power requirements of the BSMS/2 are met by two modules PSB1 and PSB2 in the back rack. The transformer is fixed on the left wall of the rack. Wiring has been reduced to a minimum.

The mains power is switched by the mains switch, located in the line modul. With the mains selector it is possible to set primary inputs of transformer on 195-215 VAC, 210-230 VAC, or 220-245 VAC. (see Primary Voltage Selection Switch on page 14).

PSB1 and PSB2 are supplied directly from the secondary side of the transformer which generates 20 galvanically isolated voltages. PSB1 and PSB2 provide their DC outputs via J18 and J19 directly to the backplane.

Grounding:

The power supply is constructed so that the different BSMS/2 function elements (SCB, SLCB, LCB,...) have individual, electrically separate power sources. These have to be connected at designated positions (see Overview of the Power Supplies (Part One) on page 12), thus allowing the different grounds to be joined together.

Figure 4: Power Supply Modules in the BSMS/2 (Back View)

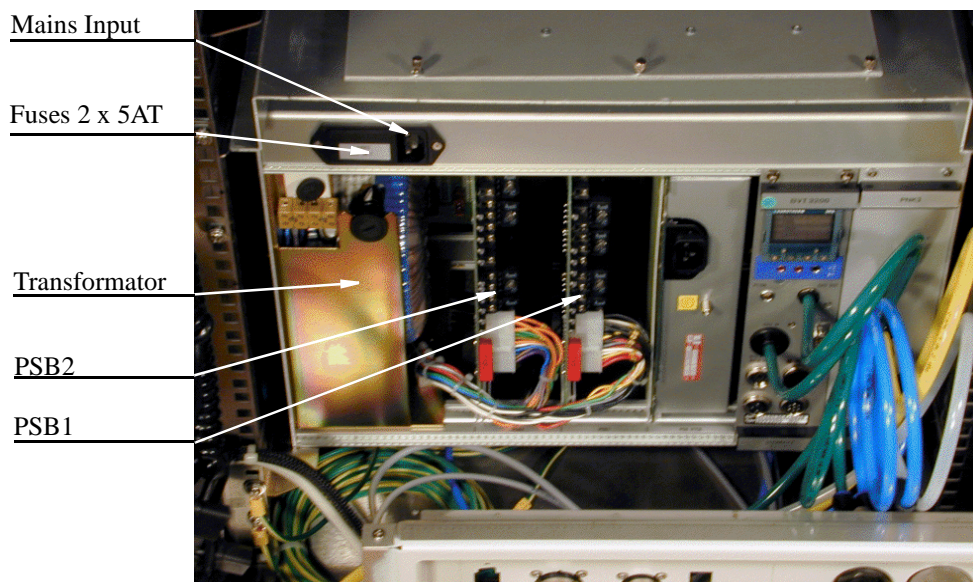

Power Supply Modules

Figure 5: Overview of the Power Supplies (Part One)

Part One

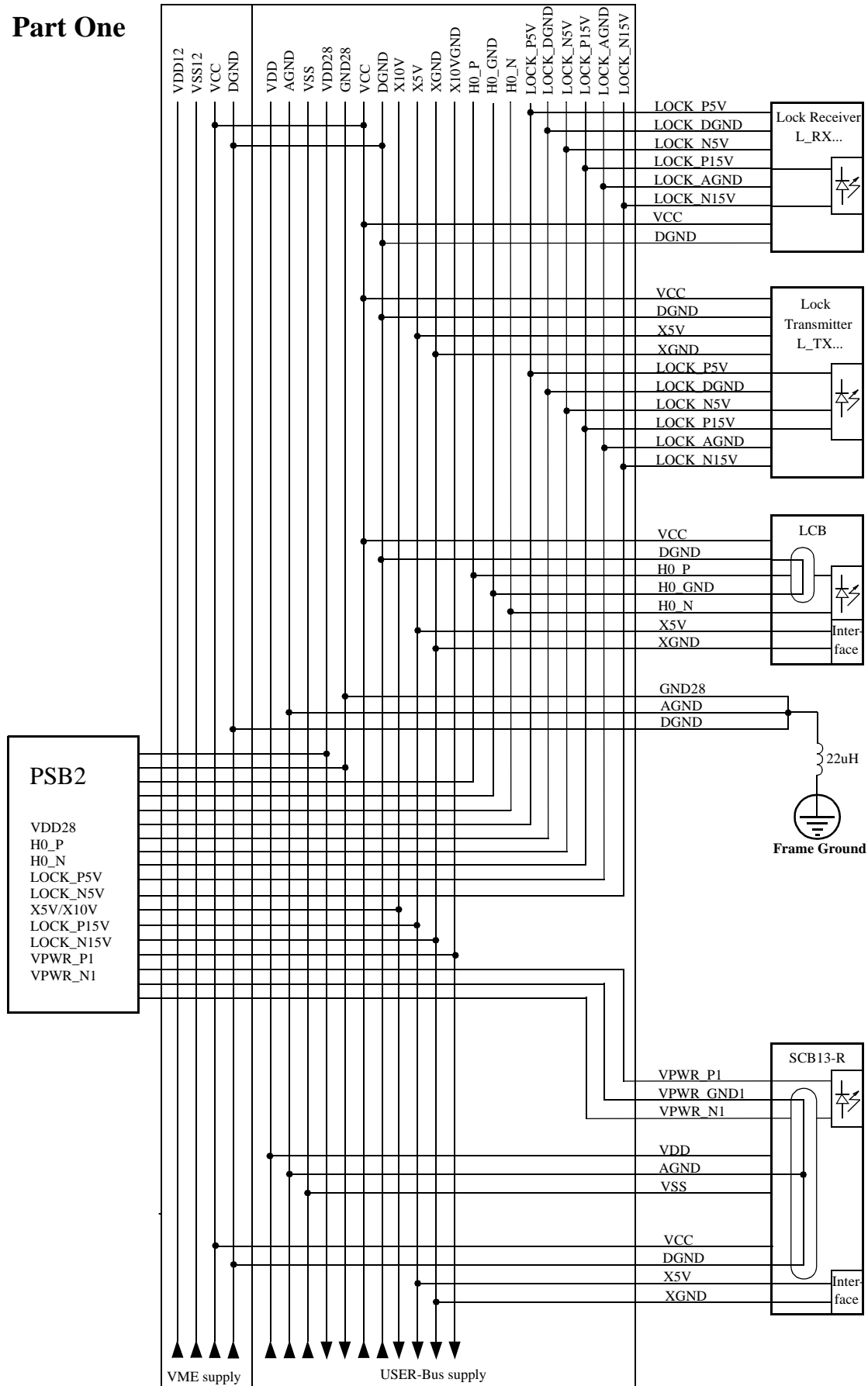
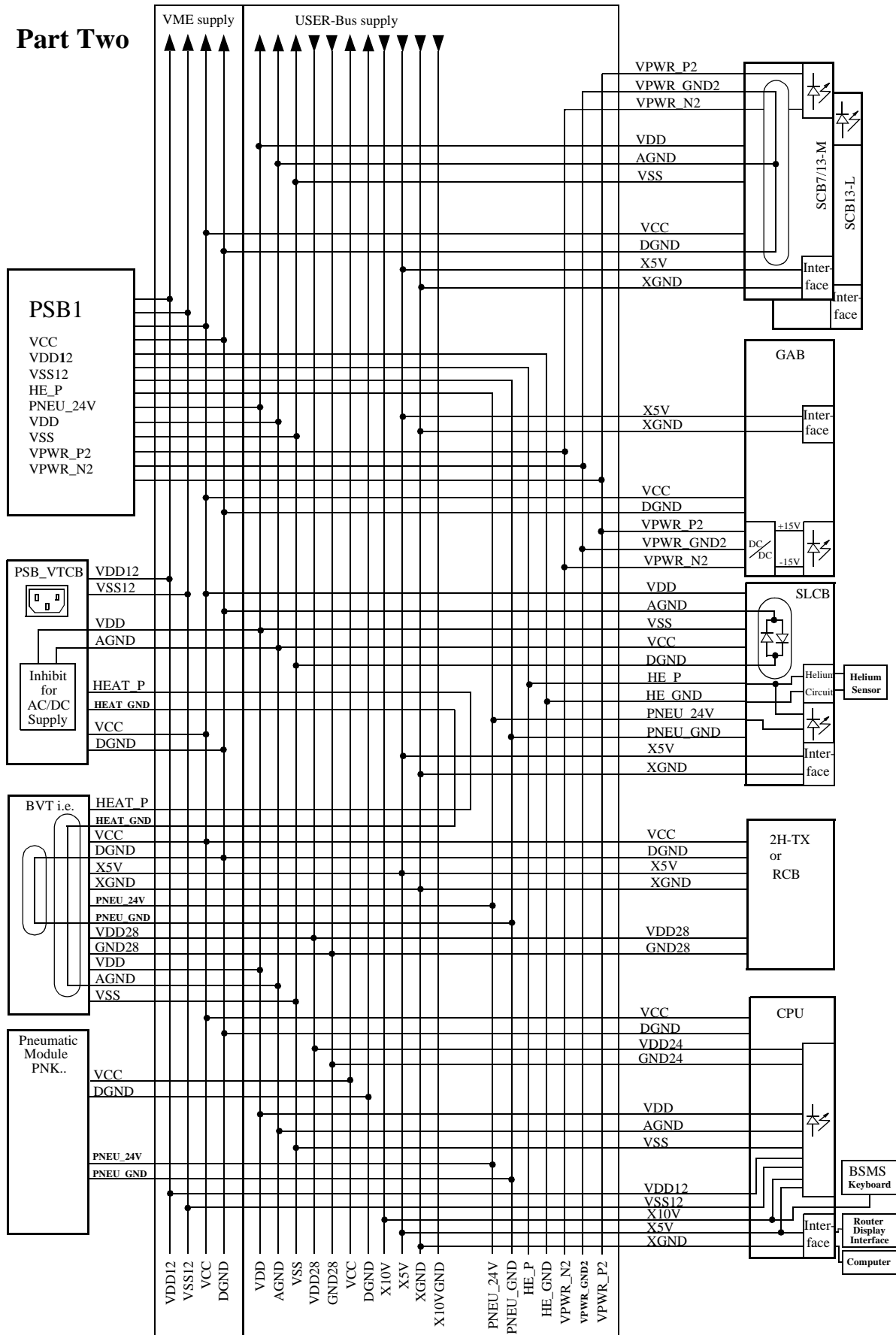

Figure 6: Overview of the Power Supplies (Part Two)



To install the power supply modules please follow the guide below, making sure to do each step in the order given.

Make sure that the mains cable is disconnected !

1. Check that the primary voltage selection switch is in the optimal position (see the sticker on the back side of the power supply module):

To avoid excessive power dissipation in the power modules, the primary voltage can be adapted by the primary voltage selection switch (shown in Figure 7). Use a coin or a screwdriver to access the switch. Generally, the primary voltage selection switch should be set to the matching range; however, if the mains power is weak, the next lower range should be chosen despite the greater power dissipation in the power supply modules.

For Example:

230 V stable mains power \Rightarrow 220-245VAC position.

230 V unstable mains power \Rightarrow 210-230VAC position.

Figure 7: Primary Voltage Selection Switch

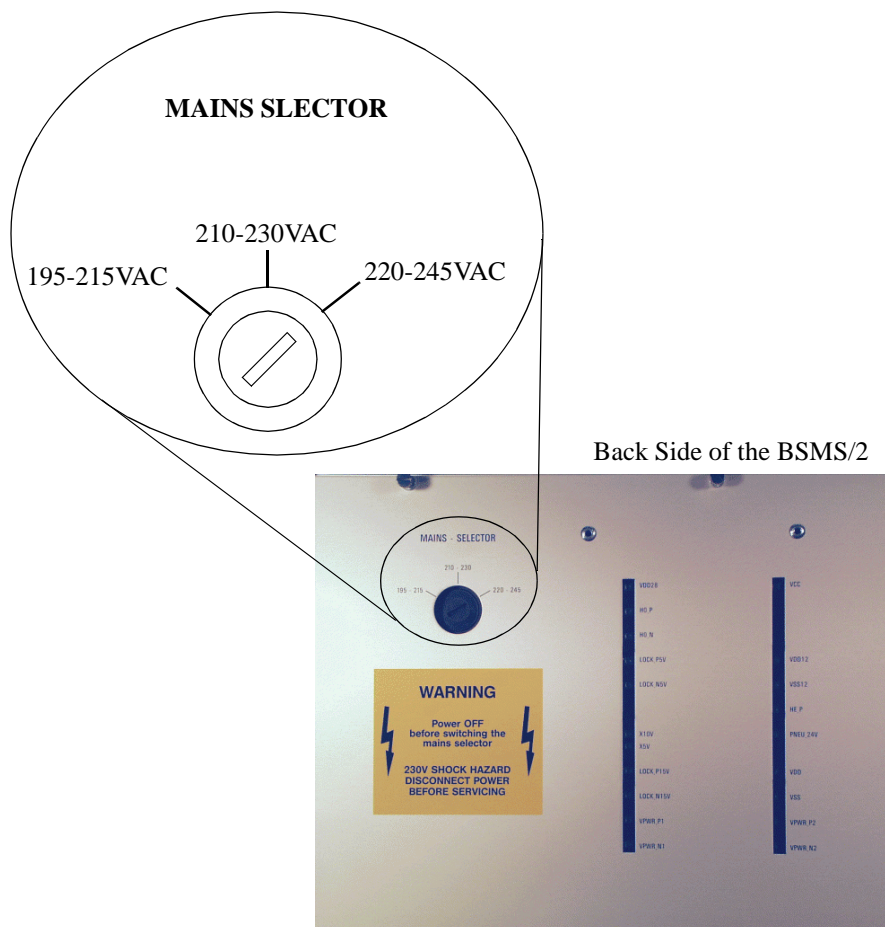
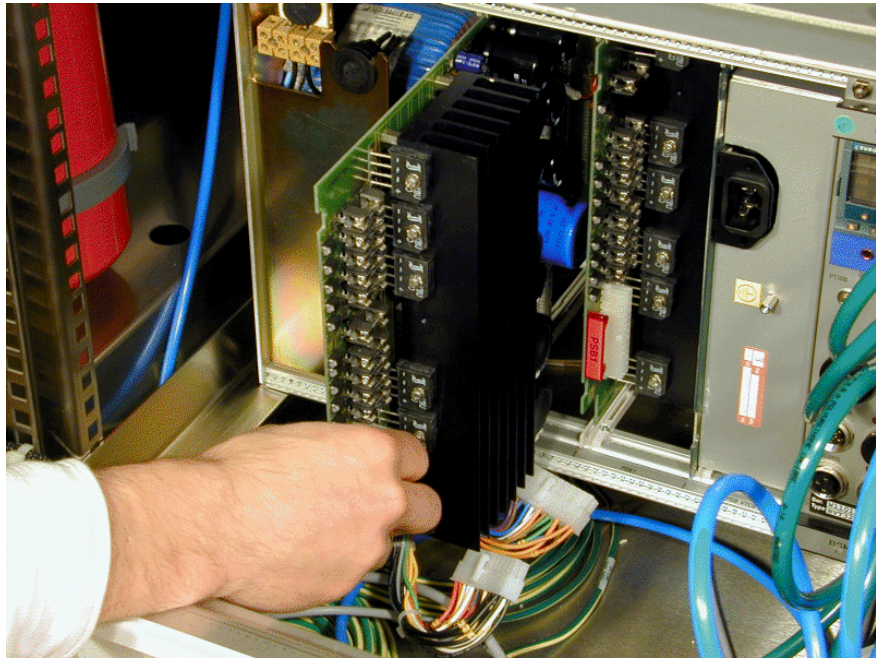

Figure 8: PSB replacement



2. Insert the power supply modules into the rack from the rear (PSB1 right, PSB2 left) and connect them with the AC-plugs.
3. Re-mount the cover plate.
4. Insert the BSMS/2 CPU into SLOT 1 (far left of front rack). Connect the BSMS keyboard to the CPU.
5. Plug in the mains cable and turn on the BSMS/2.
6. All voltage LED's on the power supply modules and on the CPU should now be lit and the BSMS keyboard should run (the display should read '*Stand By*').
7. In case of a problem, switch off the power supply and check the fuses (see also Troubleshooting on page 16).

1. First check if one of the PSB LED's is not lit. If so, look at the two fans above the power supply modules. If one of them doesn't run, that could be the cause for an overheat protection of voltage regulator. In this case the fuse doesn't have to be blown. (For fan replacement see Figure 8)
2. Switch the BSMS/2 off and disconnect the mains power cable.
3. Verify that the primary voltage selection switch on the power supply module is in the correct position (see Installation on page 14).
4. Open the cover plate and replace the fuse corresponding to the LED that doesn't light. (For further information see Fuses 3.4)
5. Now connect the mains power cable, turn on the mains switch and see if the LED lights.
6. If the same fault occurs again plug out all modules in the front and back rack on which the defective supply is used (see Figure 5 and 6). Replace the fuse (Step 1 to 4). Switch on the mains and if still a LED doesn't light the defect is located on this PSB. Otherwise plug in the first module and switch on the mains switch. Check the LED's and continue with the next module until a module causes the DC interruption. The defective part is located and has to be replaced by the BRUKER Troubleshooter.
7. Change a fan.

Figure 9: Fan replacement 1

Disconnect all cables on front side of the BSMS/2 and pull it out of the cabinet.

remove Line Module screws

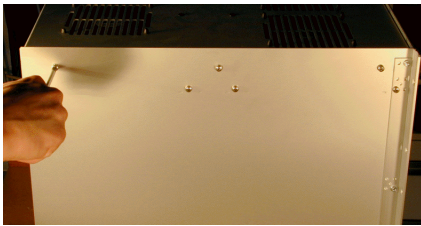

solder out the two wires

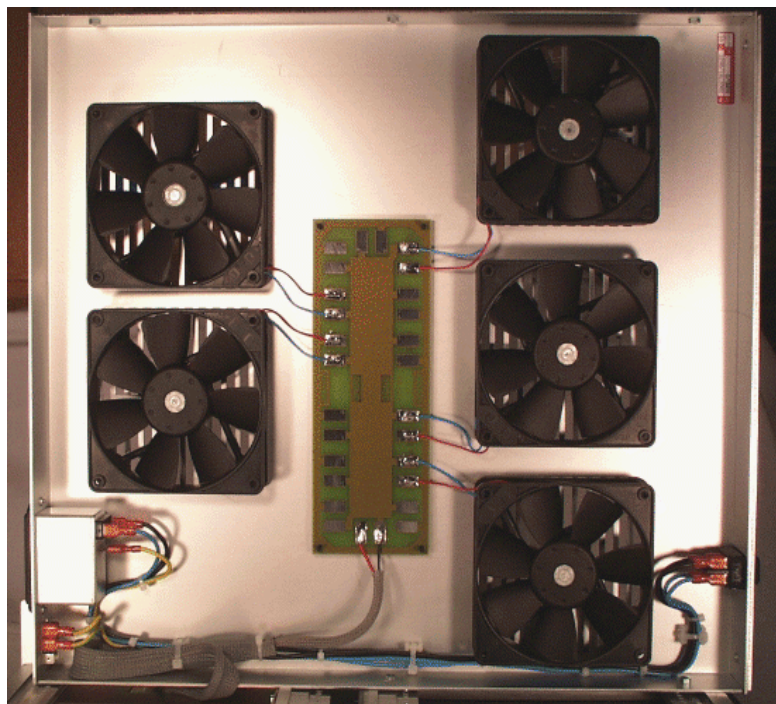
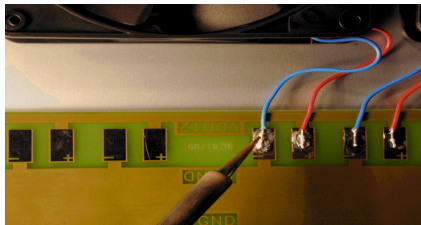
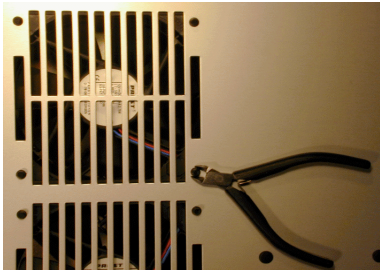
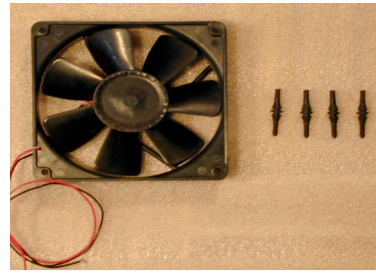

Figure 10: Fan replacement 2

cut fan rubber fittings



get a fan repair set



fix the rubber fittings

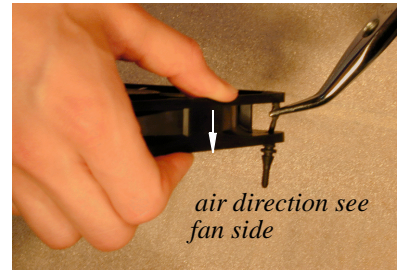

fan with rubber fittings

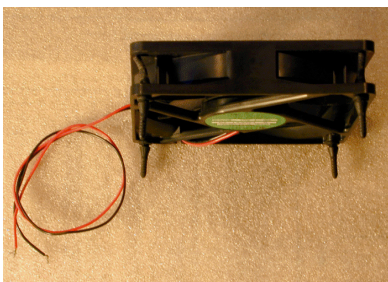

place the fan wire side to the solderpads

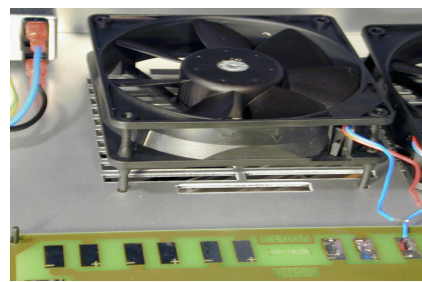

solder the wires red => +
black or blue => -

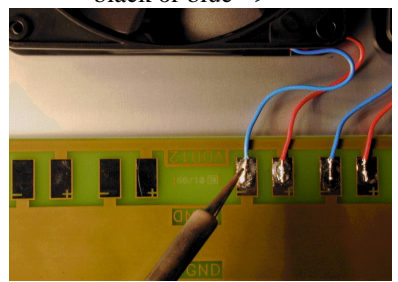

pull rubber fittings till they snap in

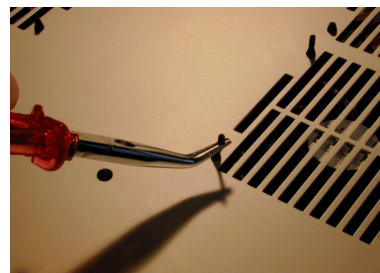

cut the rubber fittings

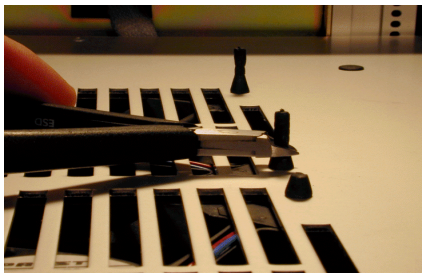

fix the line module screws

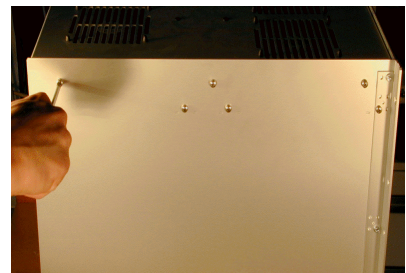

Replacement of a Power Supply Board

3.4

Power Supply Modules

Figure 11: Replacement step by step

Loosen the four screws and remove the cooling air channel.

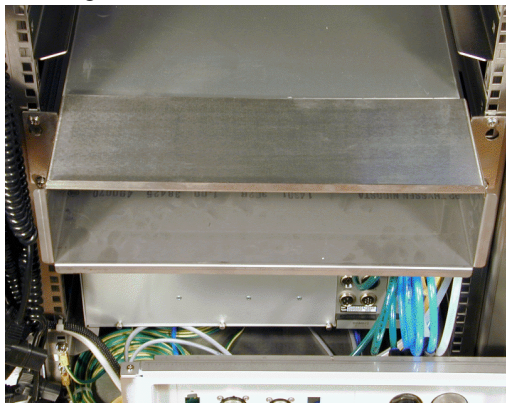

Remove all eight screws of the BSMS/2 rack.



Pull the BSMS/2 approximately 15cm (6 inch) out of the cabinet.

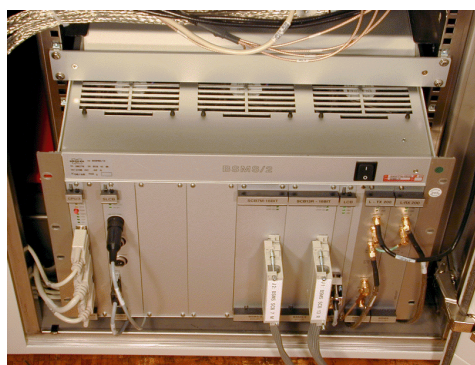

Make shure that the mains switch is turned off and the mains cable is plugged out !
Then remove the back panel.

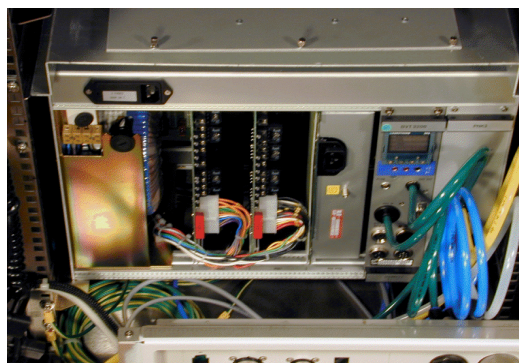

Disconnect the two AC-connectors.

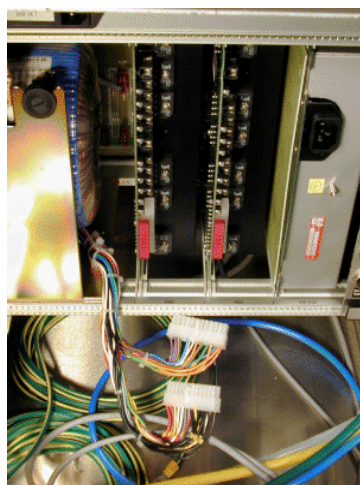

Exchange the defective power supply module.

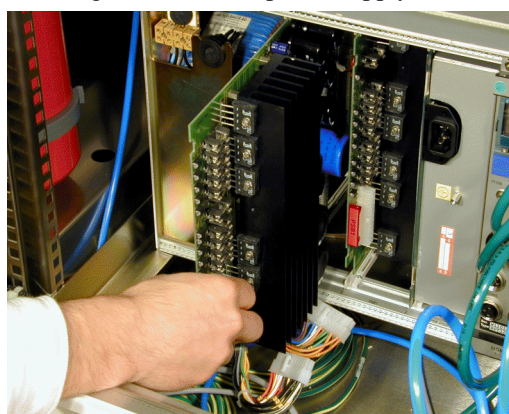

Open the backpanel of the BSMS/2. The fuses are located on each PSB behind the corresponding LED's. To exchange a fuse, it is not necessary to plug out the PSB. The DC-supply names are printed on the backpanel. For ratings of the fuses refer to Figure 11.

Figure 12: Fuse replacement

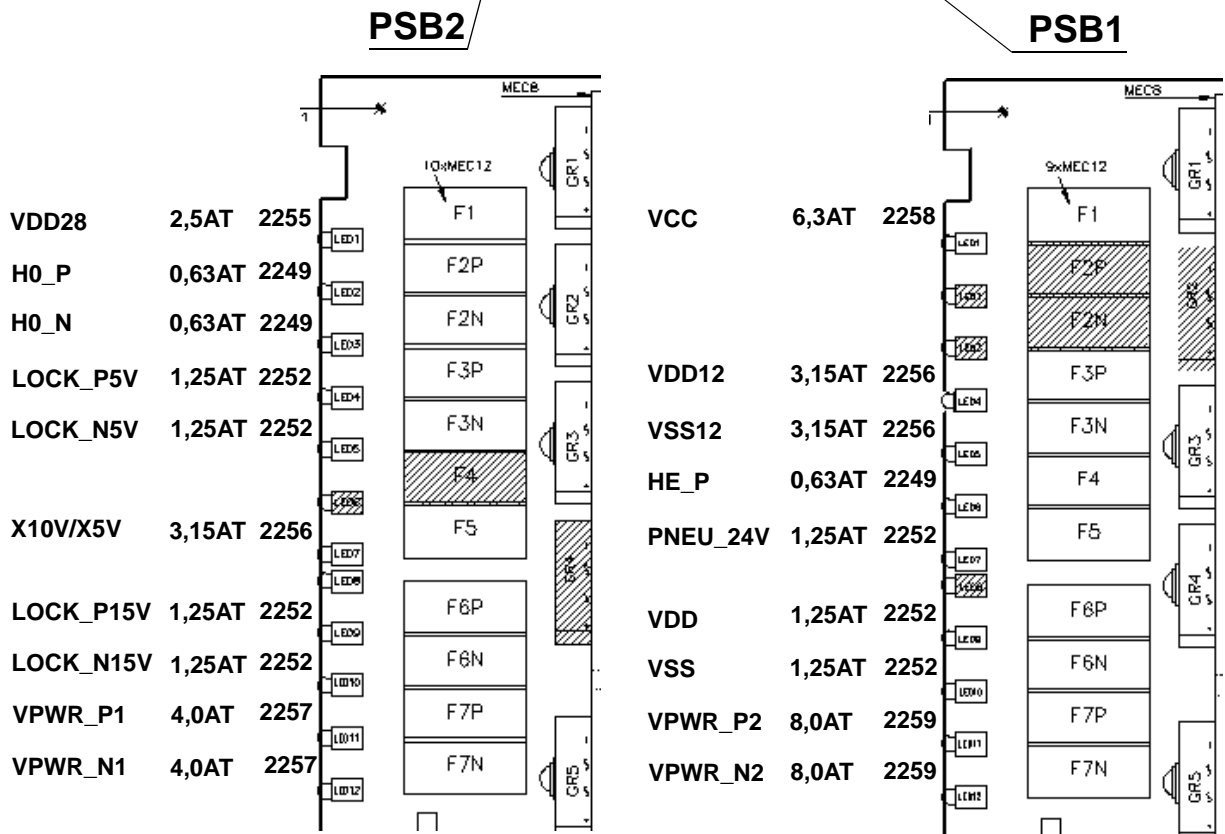
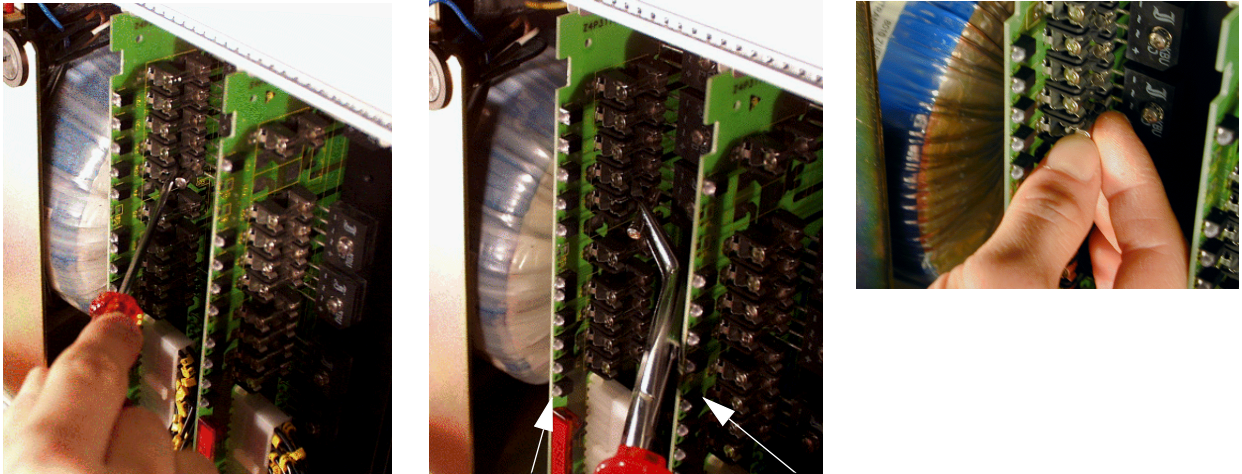

Power Supply Modules

Table 3. Corresponding operation indicator LED's

Power Supply Board	PSB Voltage (LED)	Operation Indicator (LED)
PSB1	HE_P	SLCB (HE_30V)
PSB1	VDD	CPU (+/-15V)
PSB1	VSS	CPU (+/-15V)
PSB2	X10V & X5V	CPU (X5V)
PSB1	PNEU_24V	SLCB (PNEU_24V)
PSB2	VDD28	CPU (VDD24)
PSB1	VDD12	CPU (+/-12V)
PSB2	VSS12	CPU (+/-12V)
PSB2	H0_P	LCB (+15V, +5V)
PSB2	H0_N	LCB (-15V)
PSB2	LOCK_P15V	L-RX (+/- 15V, L-PWR), L-TX (L-PWR)
PSB2	LOCK_N15V	L-RX (+/- 15V, L-PWR)
PSB2	LOCK_P5V	L-TX (+/- 5V)
PSB2	LOCK_N5V	L-TX (+/- 5V, L-PWR)
PSB1	VCC	READY and ERROR LED's on all boards. If none are lit, VCC is defective.
PSB2	VPWR_N1	SCB R in SLOT 12 (VPWR_VSS)
PSB2	VPWR_P1	SCB R in SLOT 12 (VPWR_VDD)
PSB1	VPWR_P2	GAB, SCB L, M in SLOT 6, 8, 10 (VPWR_VDD)
PSB1	VPWR_N2	GAB, SCB L, M in SLOT 6, 8, 10 (VPWR_VSS)

Regulated and non-regulated voltages are shown in Table 4 and Table 5, respectively. The following notes are applicable to both tables.

1. Voltages were measured with a true RMS DVM. The voltage ripple was determined with an oscilloscope and so gives an approximate value.
2. The rated load was simulated by a resistor.

Table 4. Regulated Voltages

Voltage Name	Reference point	Voltage at rated load	Current at rated load	Voltage ripple
VCC	DGND	5 +/- 0.1 V	5.0 A	20 mV
VDD12	DGND	12 +/- 0.7 V	2.5 A	30 mV
VSS12	DGND	-12 +/- 0.7 V	2.5 A	30 mV
H0_P	H0_GND	29.5 +/- 1.8 V	0.5 A	20 mV
H0_N	H0_GND	-29.5 +/- 1.8 V	0.5 A	20 mV
LOCK_P15V	LOCK_AGND	15 +/- 0.6 V	1.0 A	20 mV
LOCK_N15V	LOCK_AGND	-15 +/- 0.6 V	1.0 A	20 mV
LOCK_P5V	LOCK_DGND	5 +/- 0.25 V	1.0 A	20 mV
LOCK_N5V	LOCK_DGND	-5 +/- 0.25 V	1.0 A	20 mV
VDD	AGND	15 +/- 0.6 V	1.0 A	20 mV
VSS	AGND	-15 +/- 0.6 V	1.0 A	20 mV
VDD28	VDD28	27.8 +/- 1.1V	2.0 A	20mV
X5V	XGND	5 +/- 0.3 V	1.0 A	20 mV

Power Supply Modules

Table 5. Non-Regulated Voltages

(Mains voltage: 230 VAC, Primary Voltage Selection Switch Position: 220-245)

Voltage Name	Reference point	Voltage at rated load	Current at rated load	Voltage ripple (mV)
VPWR_P1	VPWR_GND1	20 - 24 V	3.5 A	800
VPWR_N1	VPWR_GND1	20 - 24 V	3.5 A	800
VPWR_P2	VPWR_GND2	20 - 25 V	6.0 A	1000
VPWR-N2	VPWR_GND2	20 - 25 V	6.0 A	1000
HE_P	HE_GND	35 - 42 V	0.4 A	1000
PNEU_24V	PNEU_GND	21 - 27 V	1.0 A	1500
X10V	X10VGND	8.5 - 11.5 V	1.5 A	800

Central Processing Board CPU

Introduction

4.1

The CPU/3 is a BSMS/2 subsystem. It plays a central role in the overall operation of the BSMS/2. First, it relates all messages from the computer or BSMS keyboard to the corresponding board (i.e., it serves as the master of the VMEbus). Second, it manages all functions in which more than one board are involved (i. e., autoshim,...).

The CPU is always located in the left-most slot 1 of the BSMS front rack as shown in Figure 13.

Figure 13: BSMS/2 CPU/3

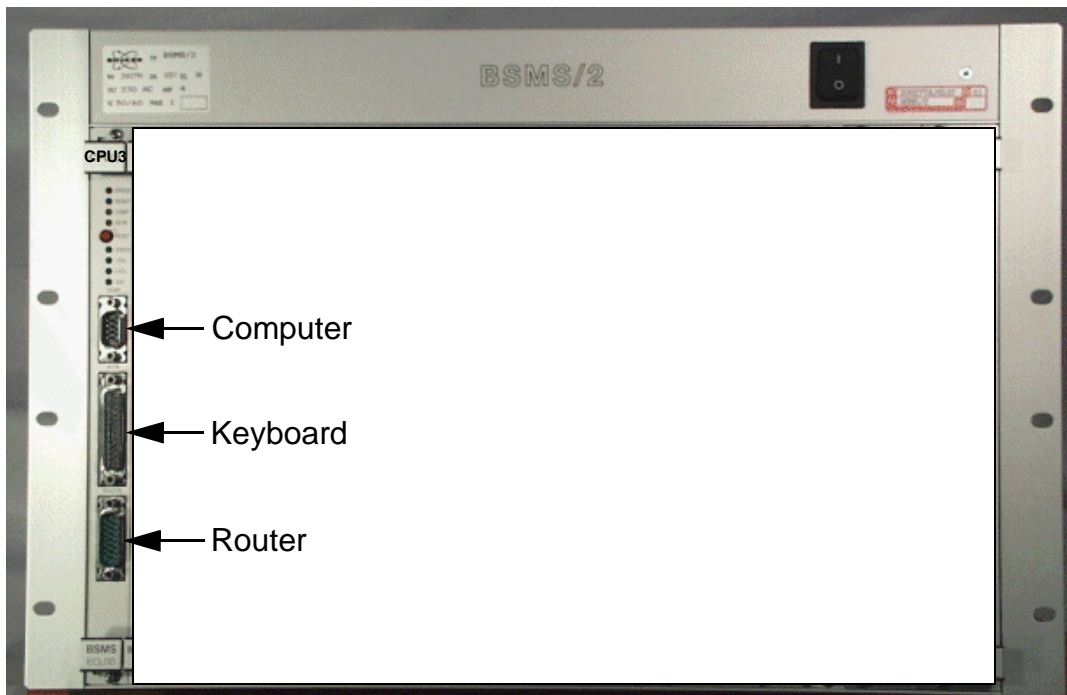

Central Processing Board CPU

Figure 14: CPU Block Diagram

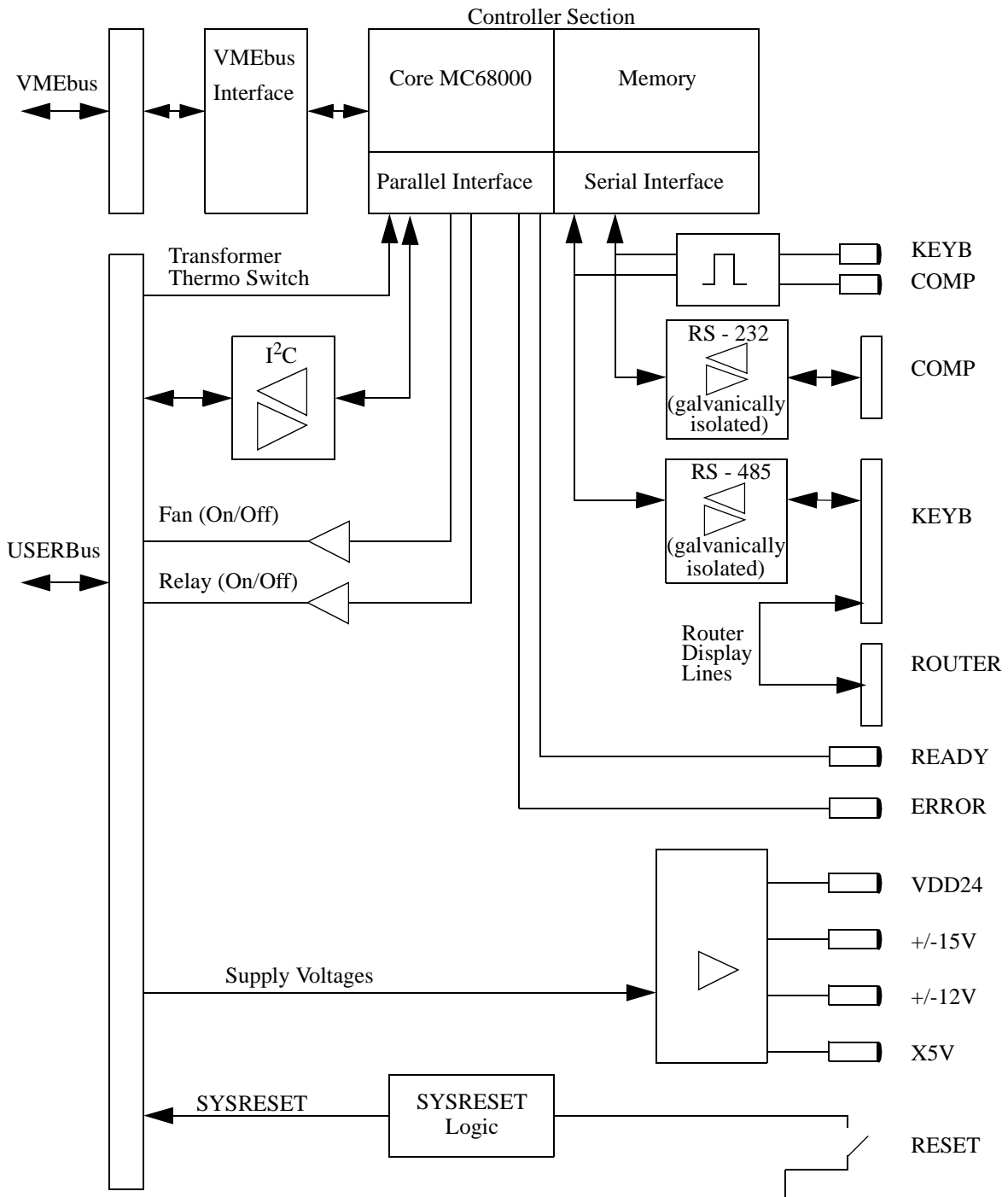

To install the CPU please follow the guide below, making sure to do each step in the order given. No hardware adjustments are necessary for the CPU! However, PLEASE NOTE that if you exchange the CPU, stored parameters for all boards will be lost. Thus, adjustments and configurations for all boards will need to be redone. So if you replace a board do it by the helpful SERVICE features of the BSMS Tool 2.0 and later. Doing this, the whole configuration will be saved on the computer and then reloaded to the new CPU (see BSMS Service Tool: Service).

1. Insert the CPU into SLOT 1 of the BSMS. Tighten the restraining screws.
2. Connect the RS232 cable (standard 9 pin connector cable 1:1, 22885). Also connect the BSMS keyboard and router display cable (22887, 22886), if appropriate.
3. Switch on the BSMS. After one second, check that all green LED's except the COMP and KEYB on the front of the CPU are lit or blinking. No error LED's should be lit.
4. Check the software version with the BSMS Service Tool and download the new software if necessary.

CPU Controller Section**4.3**

The Controller Section on the BSMS/2 CPU/3 consists of the single chip microcontroller MC68306. The MC68306 is an integrated processor containing an MC68EC000 core and parallel and serial interfaces. The VMEbus interface on the BSMS/2 CPU/3 is realised with a programmable device and some ABT drivers.

Apart from the memory needed to run the firmware on the CPU there is a part of memory which enables the whole BSMS/2 configuration to be saved non-volatile. The application software runs on a real time operating system and can be downloaded via the serial link to the computer (see BSMS/2 Service Tool Manual).

CPU Peripheral Section**4.4**

The Peripheral Section handles all the BSMS/2 special interfaces on the CPU/3.

The following functions are supported:

1. One galvanically isolated RS232 interface for the serial link with the computer.
2. One galvanically isolated RS485 interface for the serial link with the BSMS keyboard.
3. A display of the traffic from the RS232 and RS485.
4. One I²C interface for global use in the BSMS.
5. A display of the supply voltages for the keyboard and VMEbus, and of the general purpose supply voltages.
6. System reset logic and source for the global hardware reset (SYSRESET). A reset on the CPU automatically resets all the boards but not vice versa. Only the BSMS keyboard cannot be reset. Instead, it displays an error message and after a few seconds boots automatically.

Central Processing Board CPU

7. Supervision of the transformer temperature. The thermoswitch of the BSMS transformer is monitored by the CPU. Should the transformer overheat, an alarm sounds and an error message appears on the BSMS keyboard.
8. Different options such as fan control and programmable relay control.

Table 6. Technical Data of the CPU Controller Section

CPU Controller Section					
			BSMS CPU/3		
Features	Processor		MC68306	Type	
	Clock		16	MHz	
	SRAM		1	MB	
	EPROM		256	kByte	boot PROM
	EEPROM		-	kByte	non-volatile memory
	FLASH		1	MB	non-volatile memory
	Timer		1	Units	
	Real Time Clock		-	Units	
	VMEbus interface		A24/A16, D8/D16	Type	
	Option I/O		-	TTL	General purpose I/O under software control
	Expansion Port		2	Units	General purpose port for CPU expansion

Central Processing Board CPU

BSMS Keyboard KBC

Introduction

5.1

The BSMS keyboard is a special input/output device which allows the user quick and easy access to the spectrometer parameters that are controlled by the BSMS/2. This chapter describes only technical details of the keyboard. General instructions for the use of the BSMS keyboard may be found in the BSMS User's Manual.

Within the BSMS keyboard are the keyboard controller board and the keyboard display board. The keyboard controller board controls the keyboard display board, on which are placed the keys, LED's, and alphanumeric display. The router display is generally controlled by the router display controller; however, all router display functions can be operated from the keyboard controller board. This is particularly useful for the display test.

BSMS Keyboard KBC

Figure 15: Layout of the BSMS Keyboard (Version BOSS)

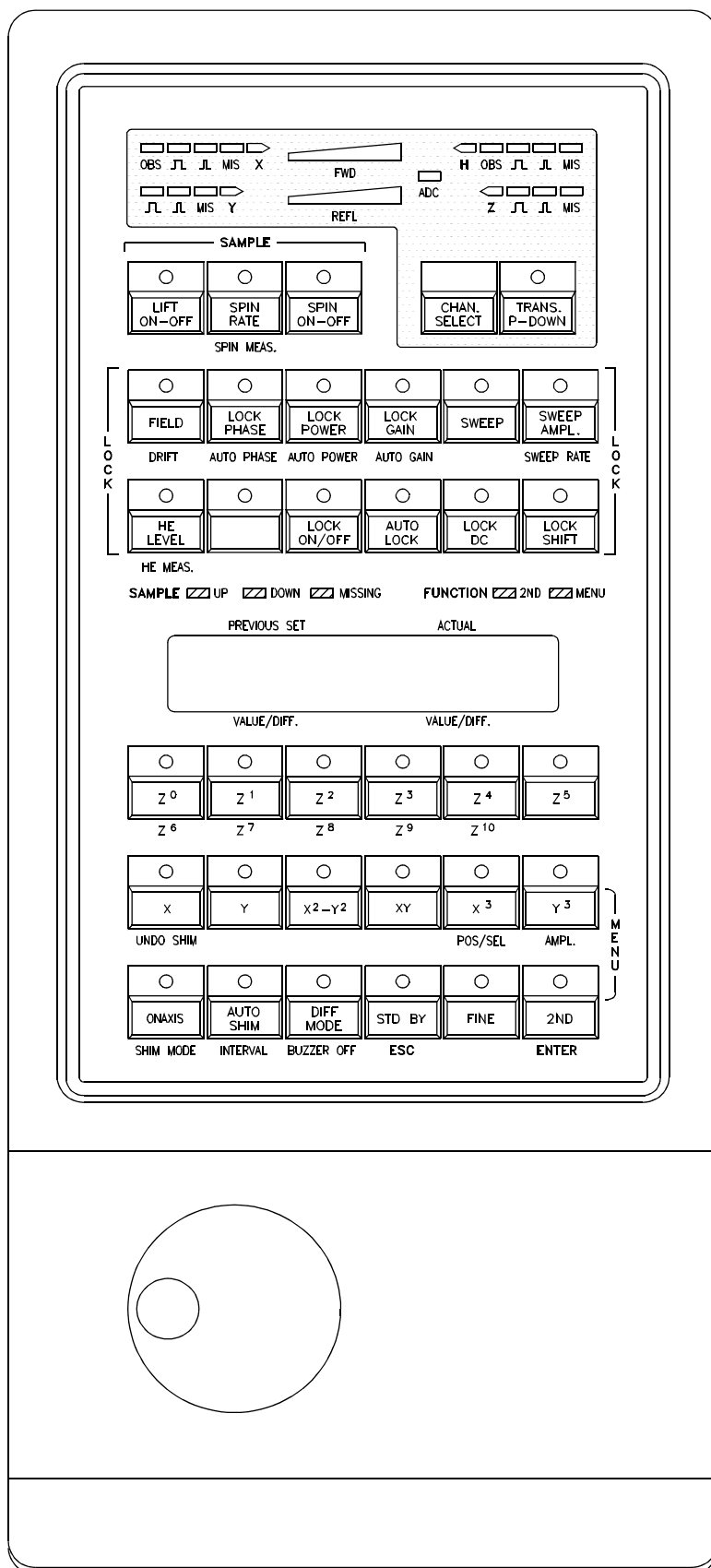
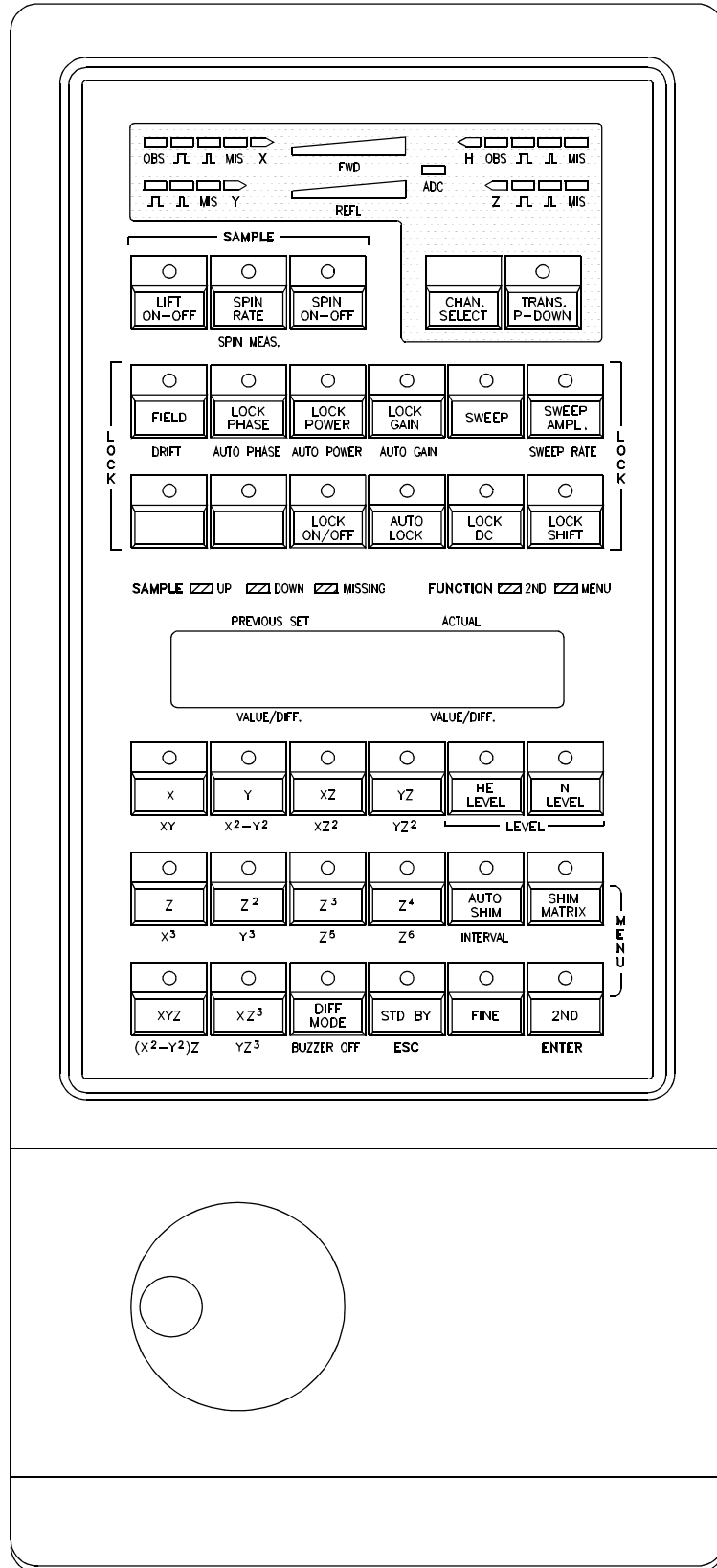
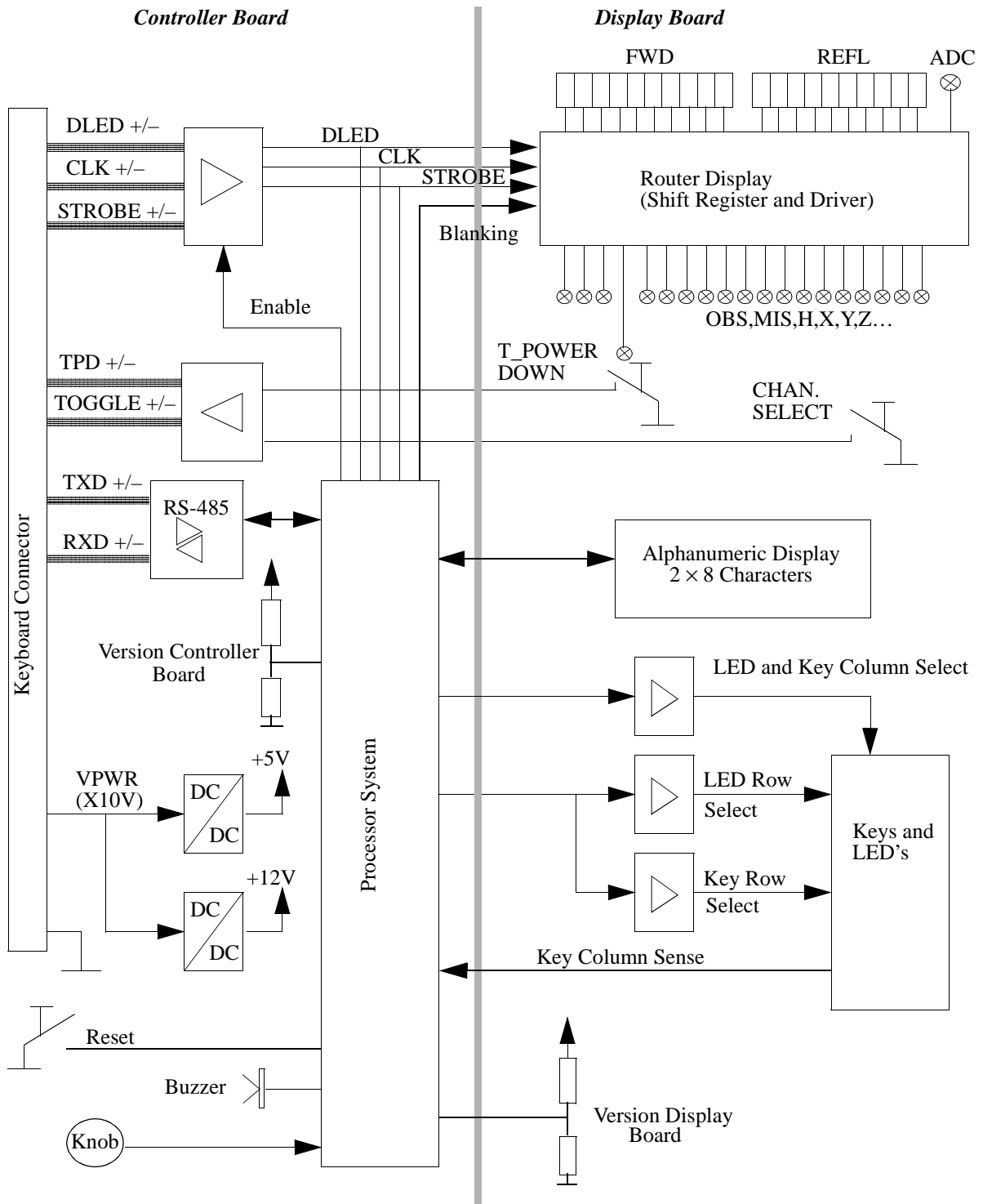

Figure 16: Layout of the BSMS Keyboard (Version HR-20)



BSMS Keyboard KBC

Figure 17: BSMS Keyboard Block Diagram



To install the keyboard please follow the guide below, making sure to do each step in the order given. No hardware adjustments are necessary for the BSMS keyboard!

1. Connect the BSMS keyboard to the CPU using a standard 25 pin cable (22887).
2. Switch on the BSMS. Check that the messages '**Booting**' and afterwards '**Connecting...**' appear on the keyboard display. After approximately one second, also verify that the green KEYB LED on the CPU is blinking. No error LED's on the CPU should be lit and no error message from the keyboard (KBC) should appear on the display.
3. Check the software version with the BSMS Service Tool and download the new software if necessary.

Keyboard Controller Board

The keyboard controller board is located in the bottom of the BSMS keyboard. It is a processor system built around a 80C535 micro-controller. The application software runs on a real time operating system and can be downloaded via the serial link with the CPU (see BSMS Service Tool Manual). The control knob and the keyboard display board are connected to the keyboard controller board.

Keyboard Display Board

All keys, LED's with drivers, and the 2 × 8 alphanumeric display of the BSMS keyboard are placed on the keyboard display board. It is connected with the keyboard controller board by a 64 wire flat cable.

Table 7. Technical Data of the BSMS Keyboard

BSMS Keyboard				
Power Supply	Input Voltage	9...11	V	
	Input Current	240	mA	In Standby Mode
		1.2	A	Displaytest
Serial Link	Level	RS485 (differential)		
	Baudrate	9600	Baud	
	Data Bit	8		
	Parity	none		
	Stop Bit	1		
	Start Bit	1		

Buses and Wiring

Line Modul (DC-Fan)

6.1

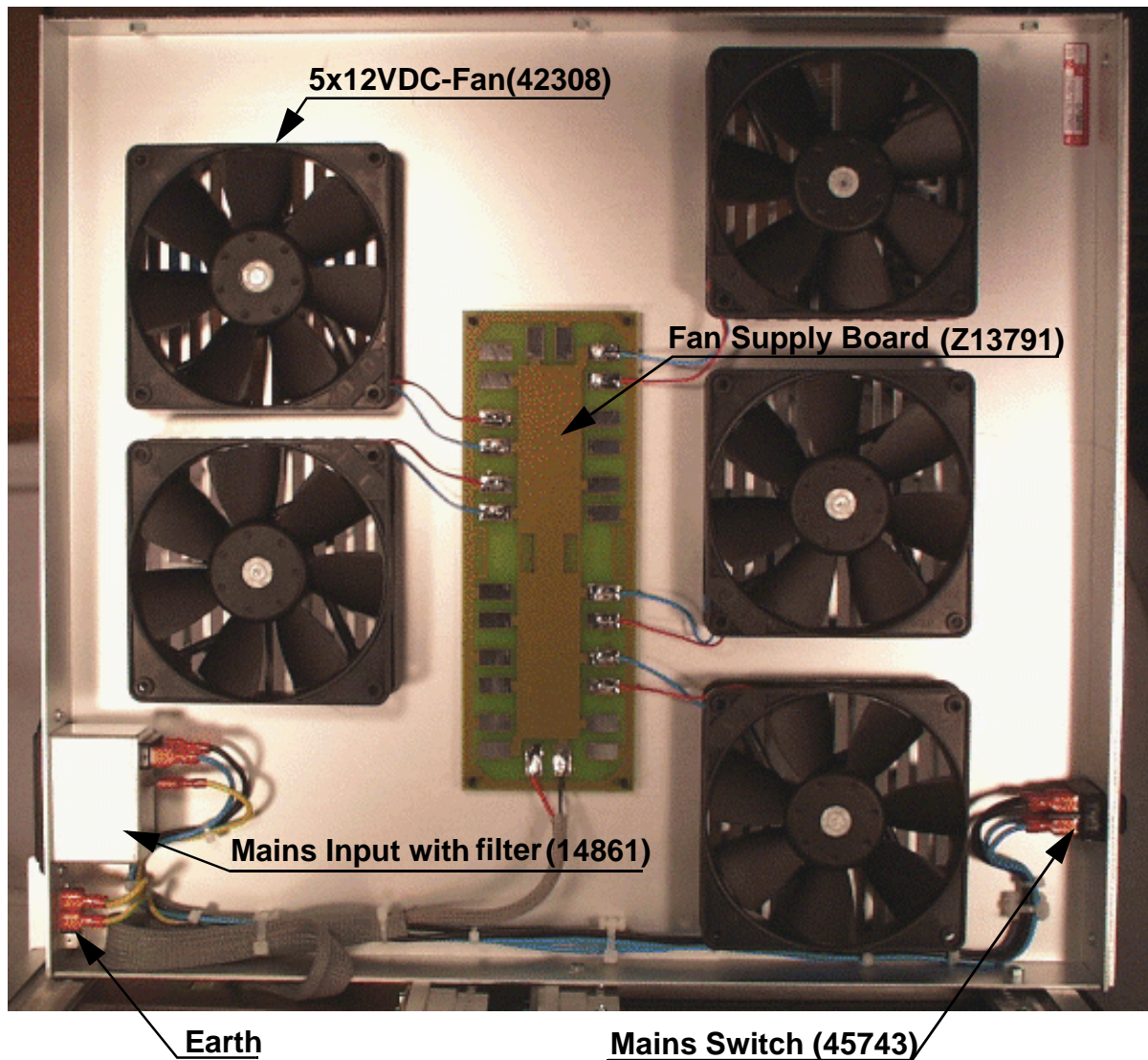

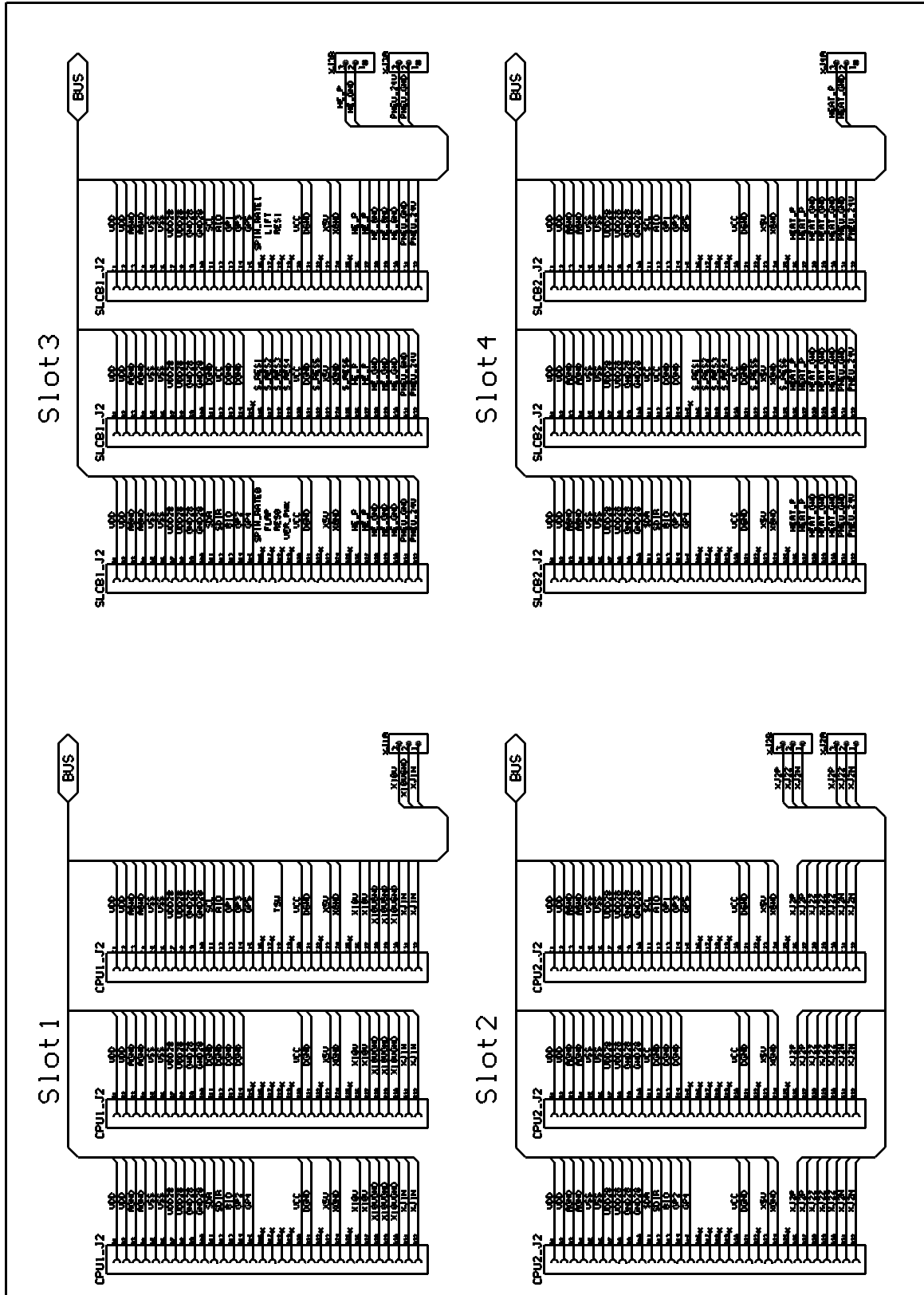

Buses and Wiring

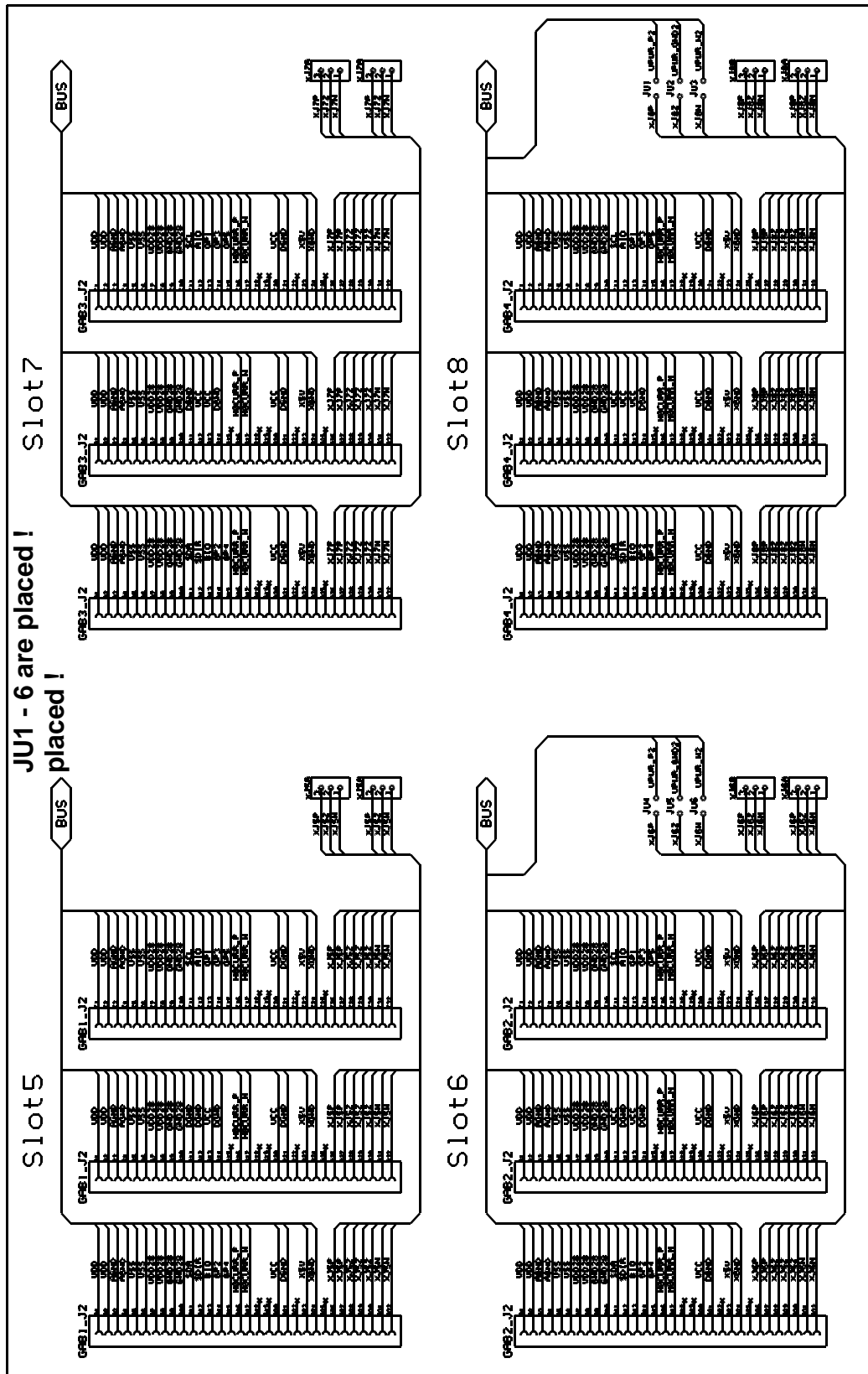

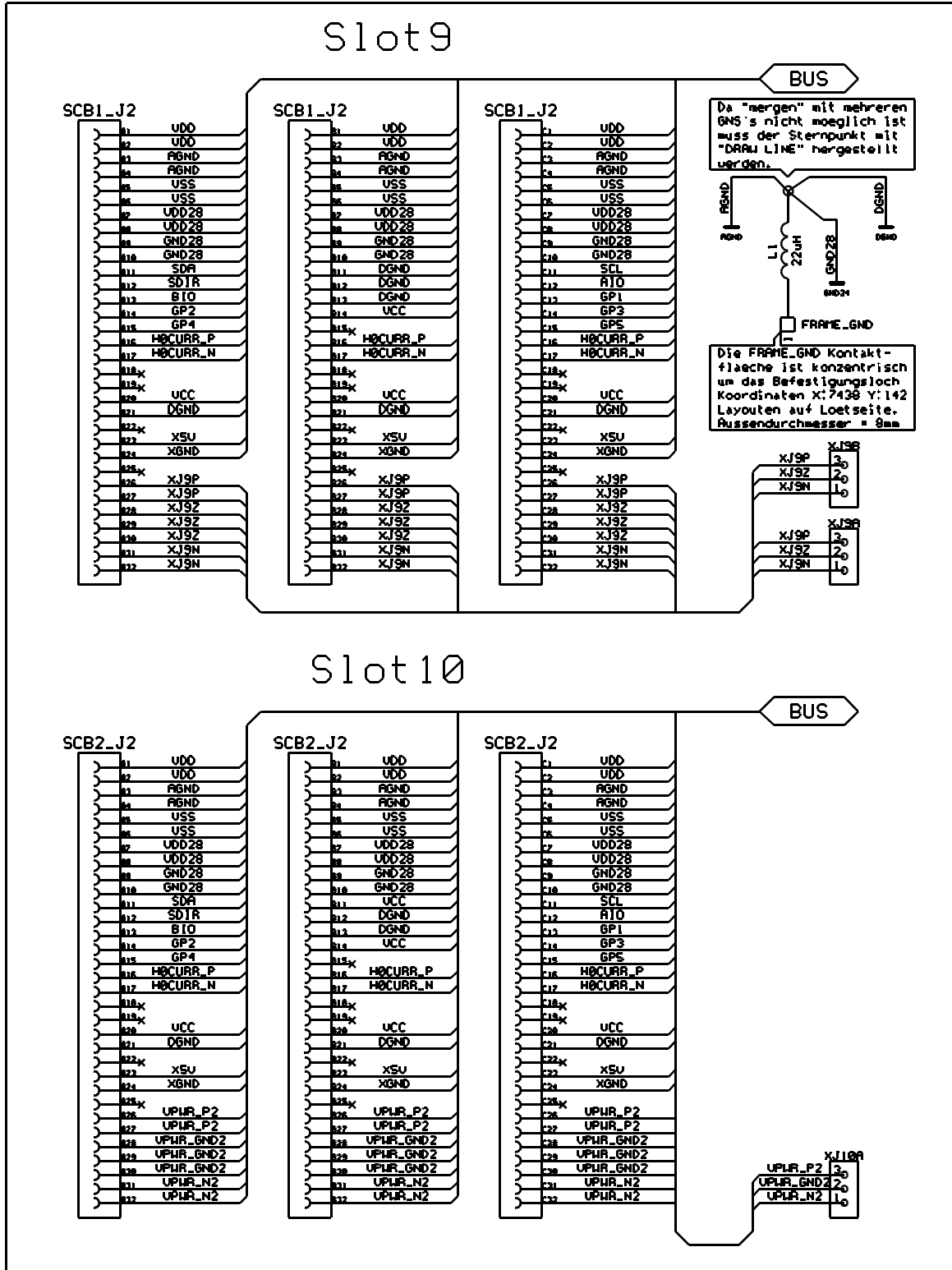

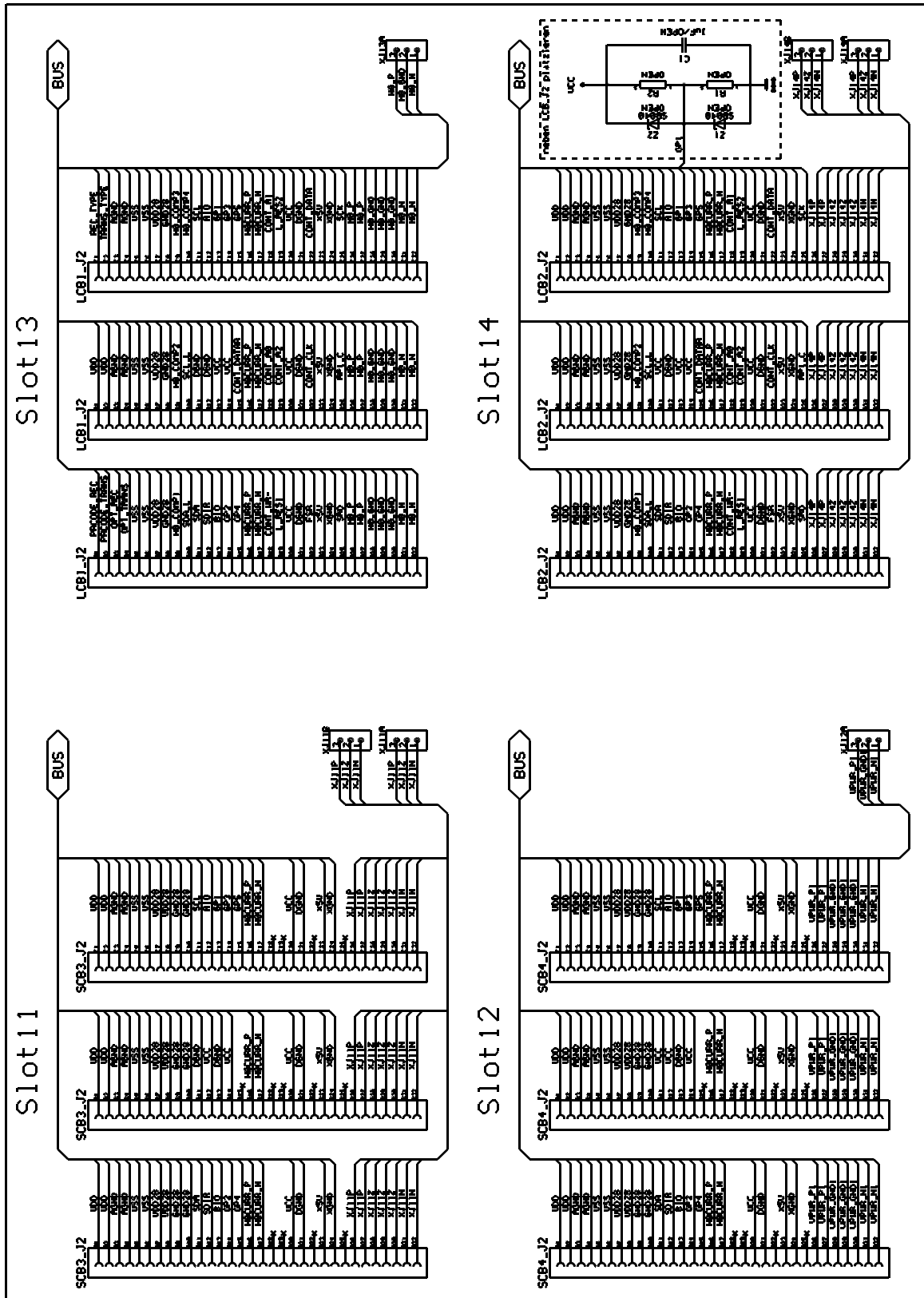

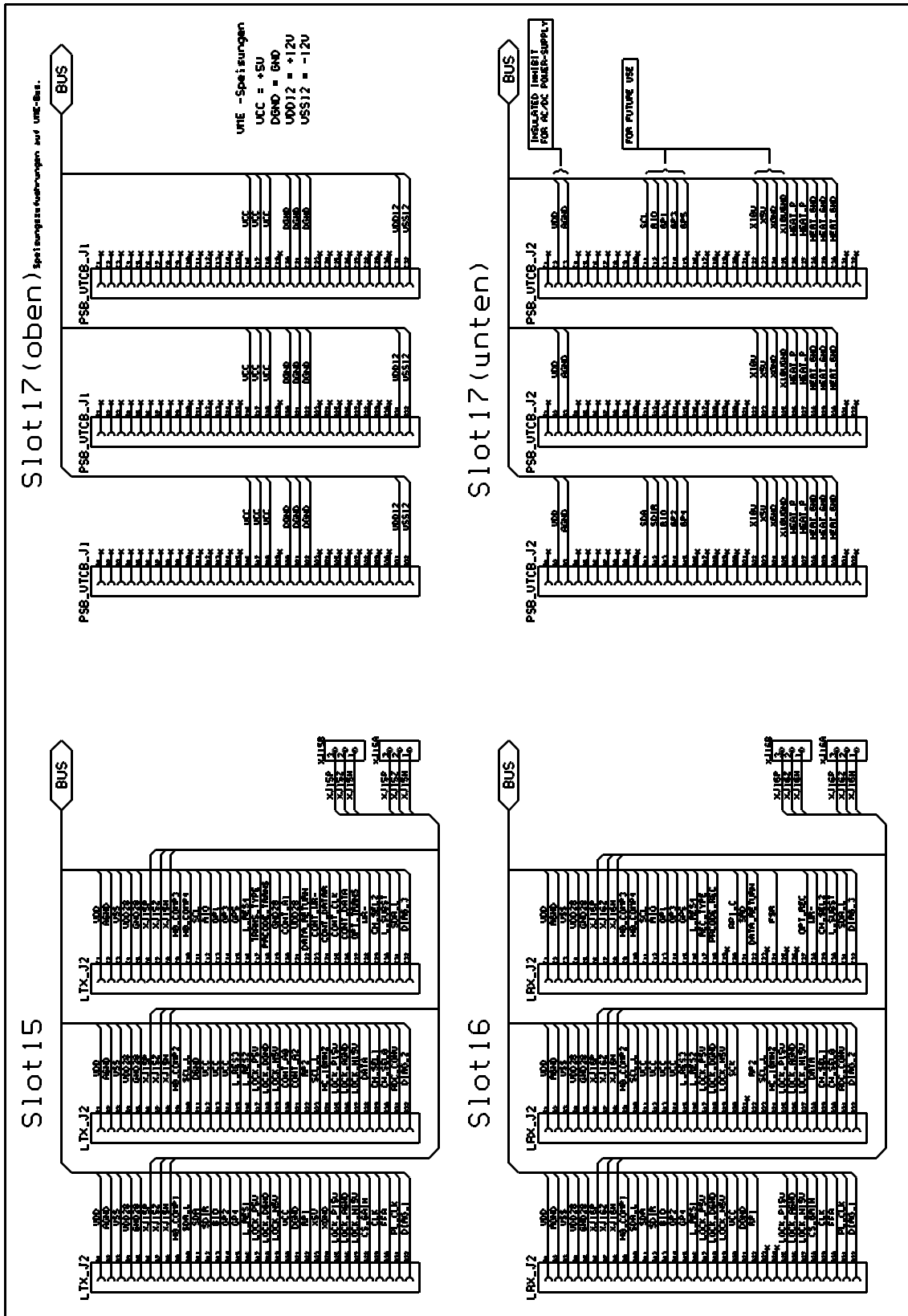

BVT

BVT and BVT-Supply

7.1

The BVT needs an additional supply Board, the BSMS/2 PS BD BVT3200 400VA (Z002840).

The following pictures show how to install these two modules into a BSMS/2 rack.

Assembling Instructions

7.2

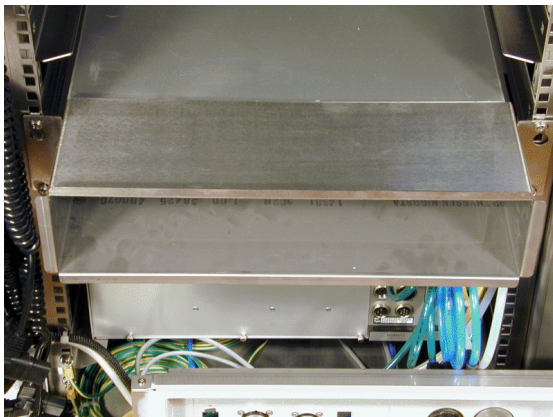

Loosen the four screws and remove the cooling air channel

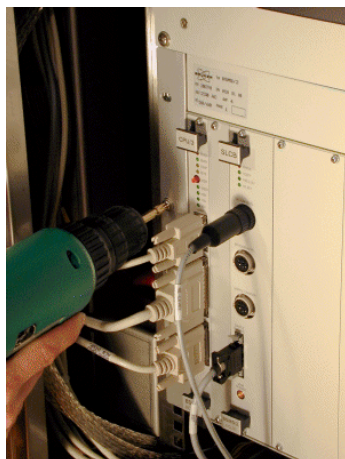

Remove all eight screws of the BSMS/2 rack.

BVT

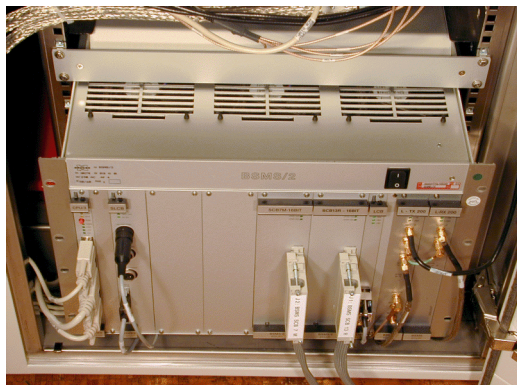

Pull the BSMS/2 approximately 15cm (6 inch) out of the cabinet.



Make sure that the mains switch is turned off and the mains cable is plugged out !
Then remove the back panel.

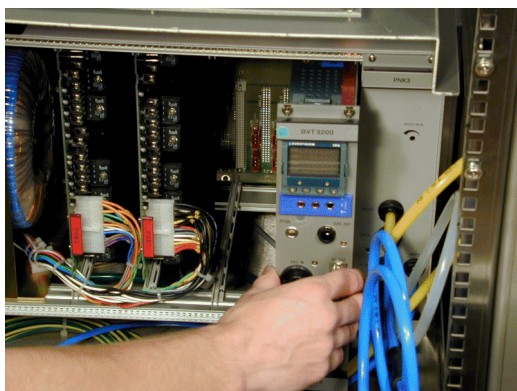

Plug in the BVT and fix the screws.

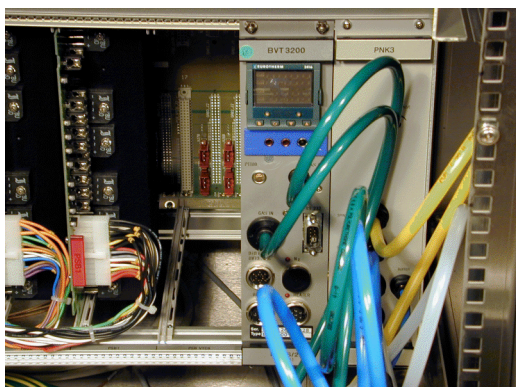

The BVT connected with the air tubes.

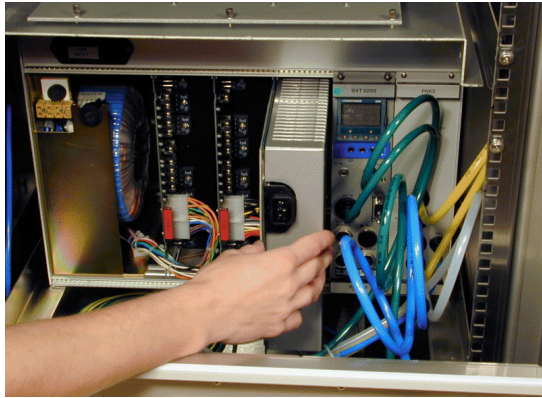

Plug in the BVT - Supply

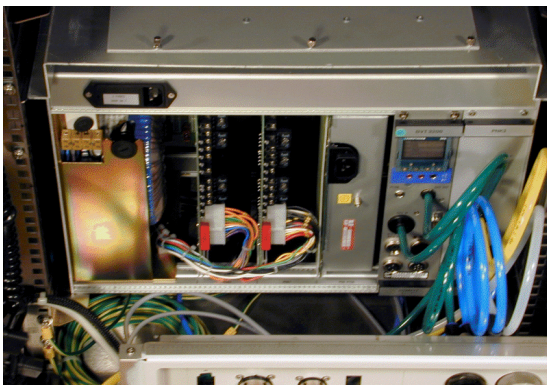

BSMS/2 ready to mount the back pannel



Connect the mains cables.

Note: For cables to or from the BVT see VTU User Manual

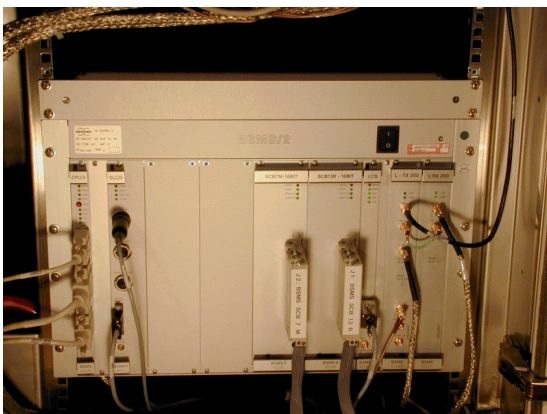

The BSMS/2 rack is pushed back an fixed to the cabinet.

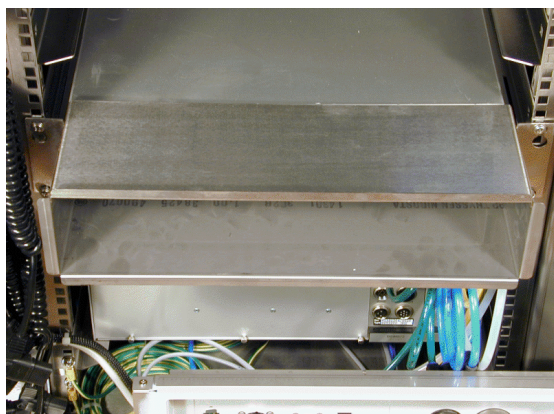

Attach the cooling air channel and tighten the screws

Schemata

Power supply PSB1 place plan

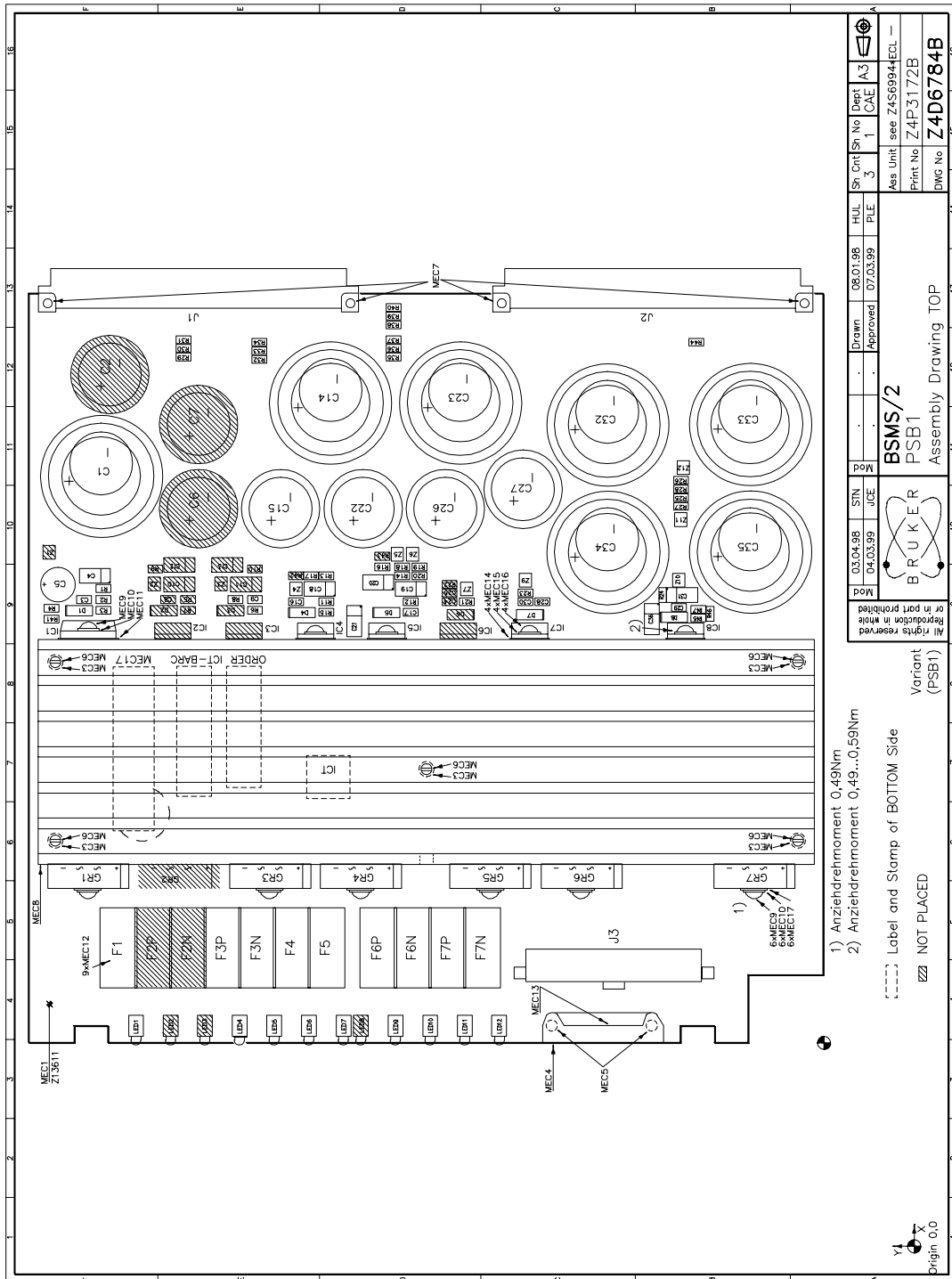

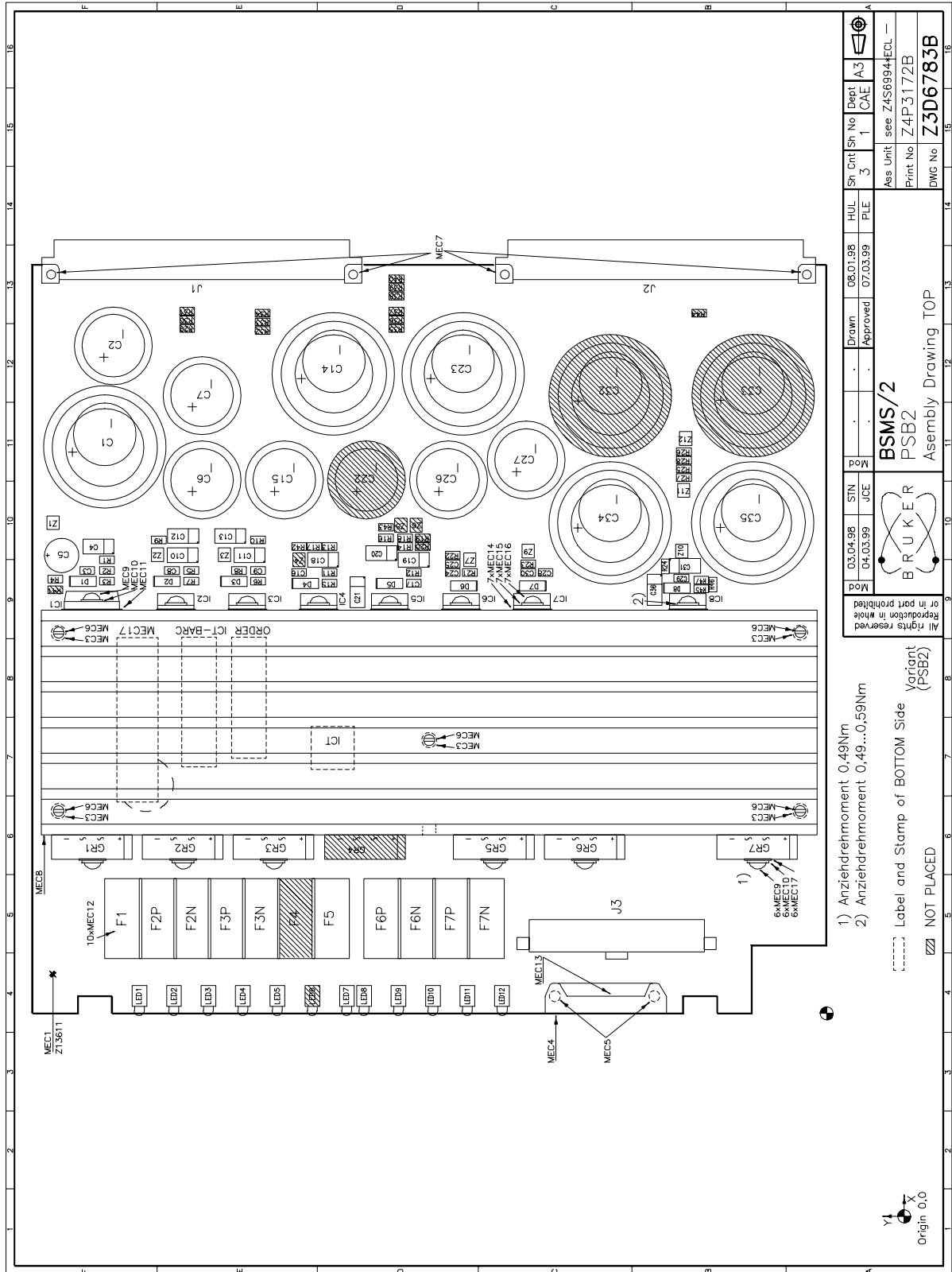

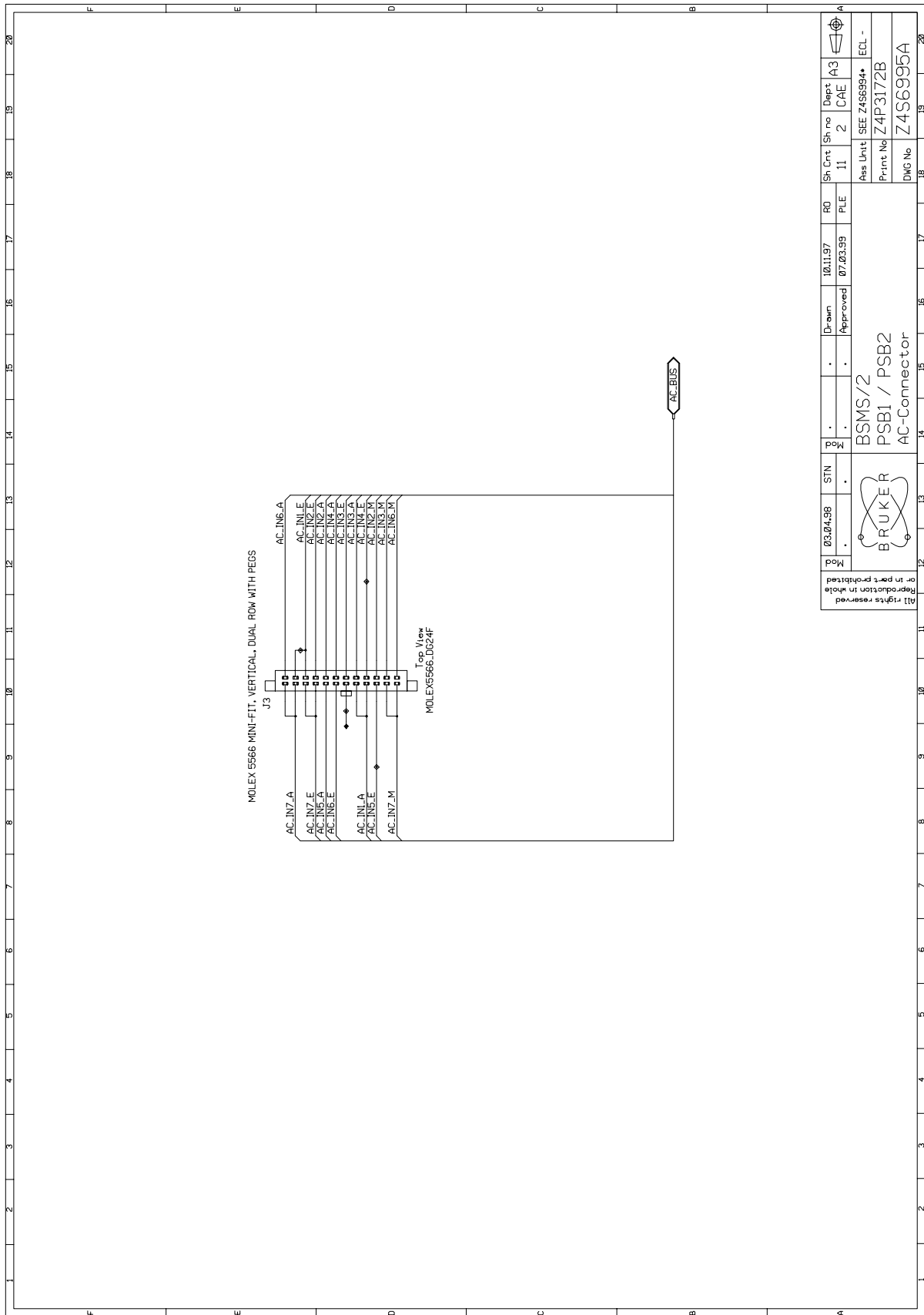

Mod	03,04,98	STN	.	Drawn	10.11.97	RO	Sh.Cnt	Sh.no	Dept
				Approved	07.03.99	PLE	11	2	CAE
BSMS/2 PSB1 / PSB2 AC-Connector									
BRUKER									
Ass Unit SEE Z456954* Print No Z4P3172B									
DWG No Z456995A									

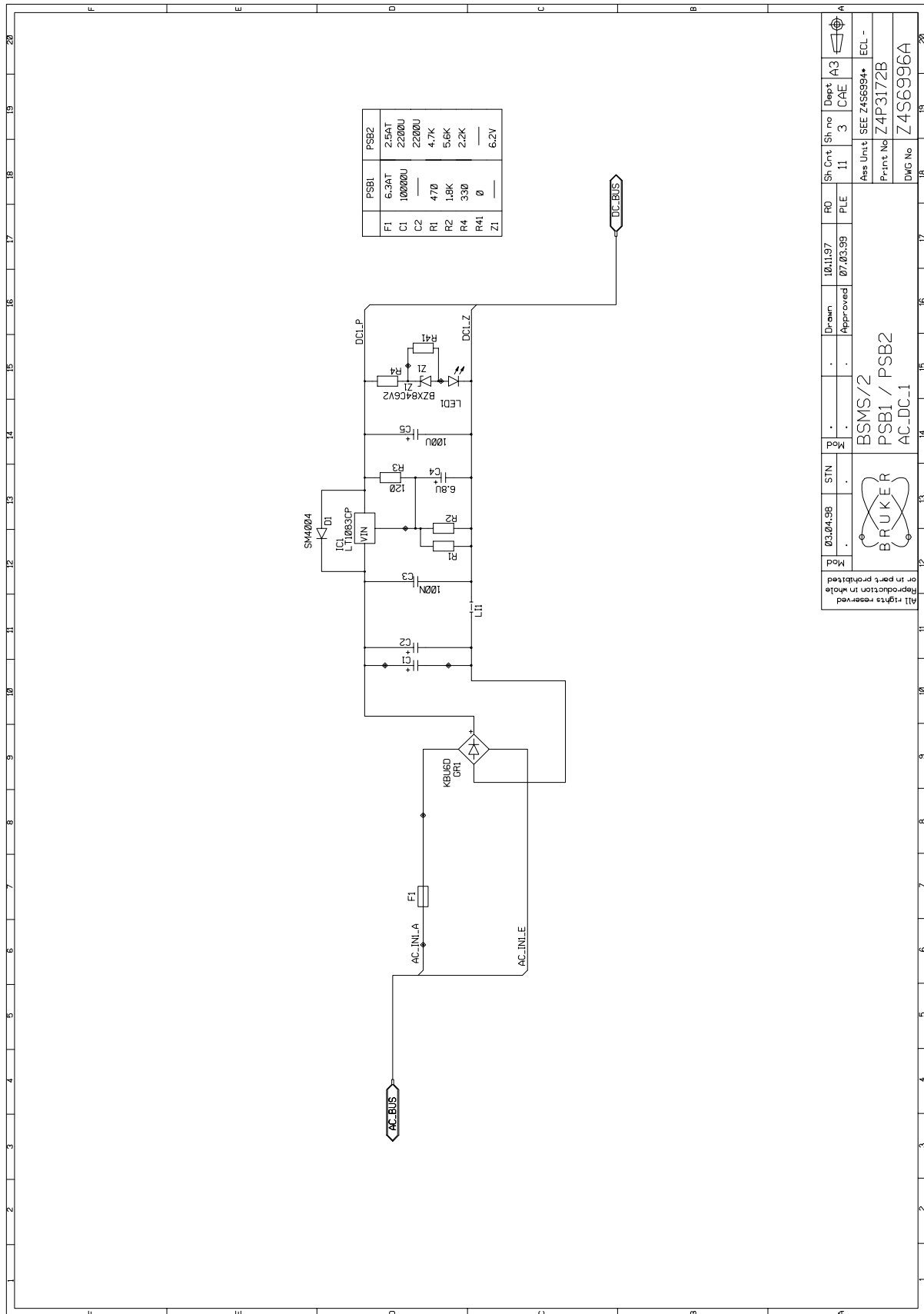

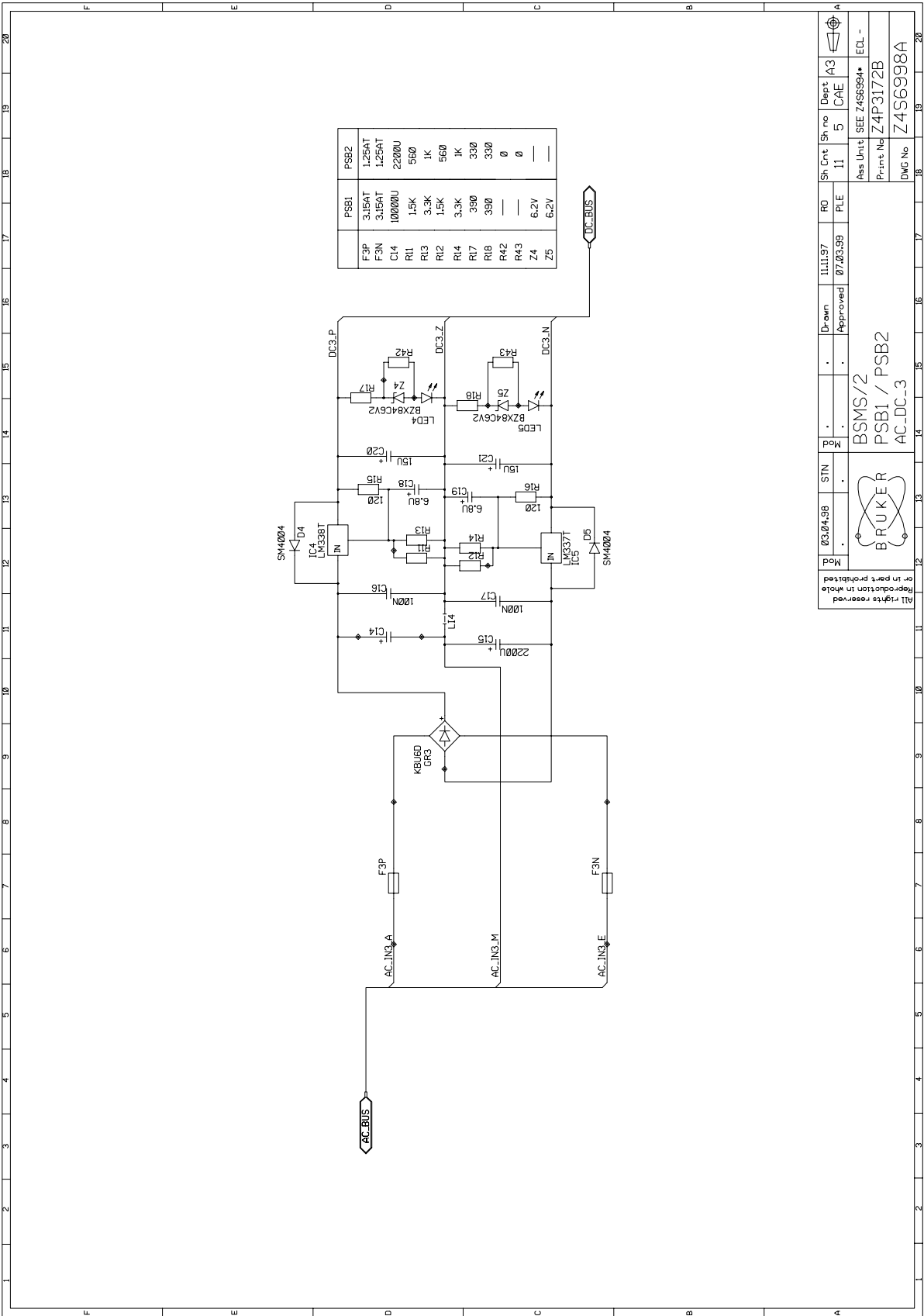

Mod 030438 STN Drawn 11.11.97 RO Sh Cnt 11 Sh no 5 Dept A3
 Approved 07.03.99 PLE
 Mod BSM5/2
 PSB1 / PSB2
 AC-DC-3
 Ass Unit SEE Z456994
 Print No Z4P3172B
 DWG No Z456998A

BRUKER

All rights reserved
 Reproduction in whole
 or in part prohibited

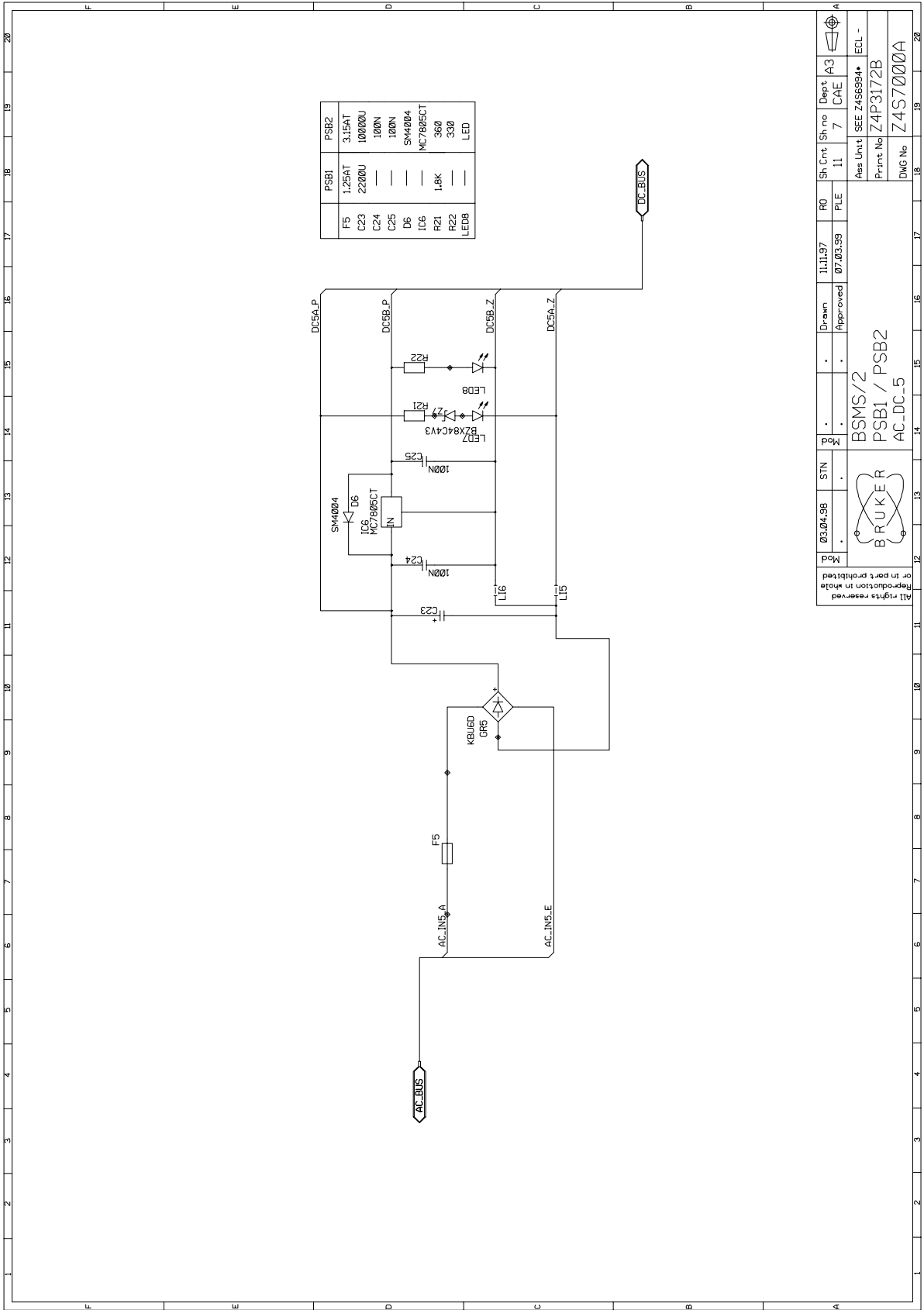

03.04.98	STN	Mod	07.03.99	Drawn	11.11.97	R0	Sh. Cnt	Sh. no	Dept	A3
				Approved		FILE	11	7	CAE	
BRUKER			BSMS/2			SEE Z4S6984*			ECL -	
AC-DC-5			PSB1 / PSB2			Z4P3172B			Print No	
AC-DC-5			AC-DC-5			Z4S7000A			DWG No	

Schemata

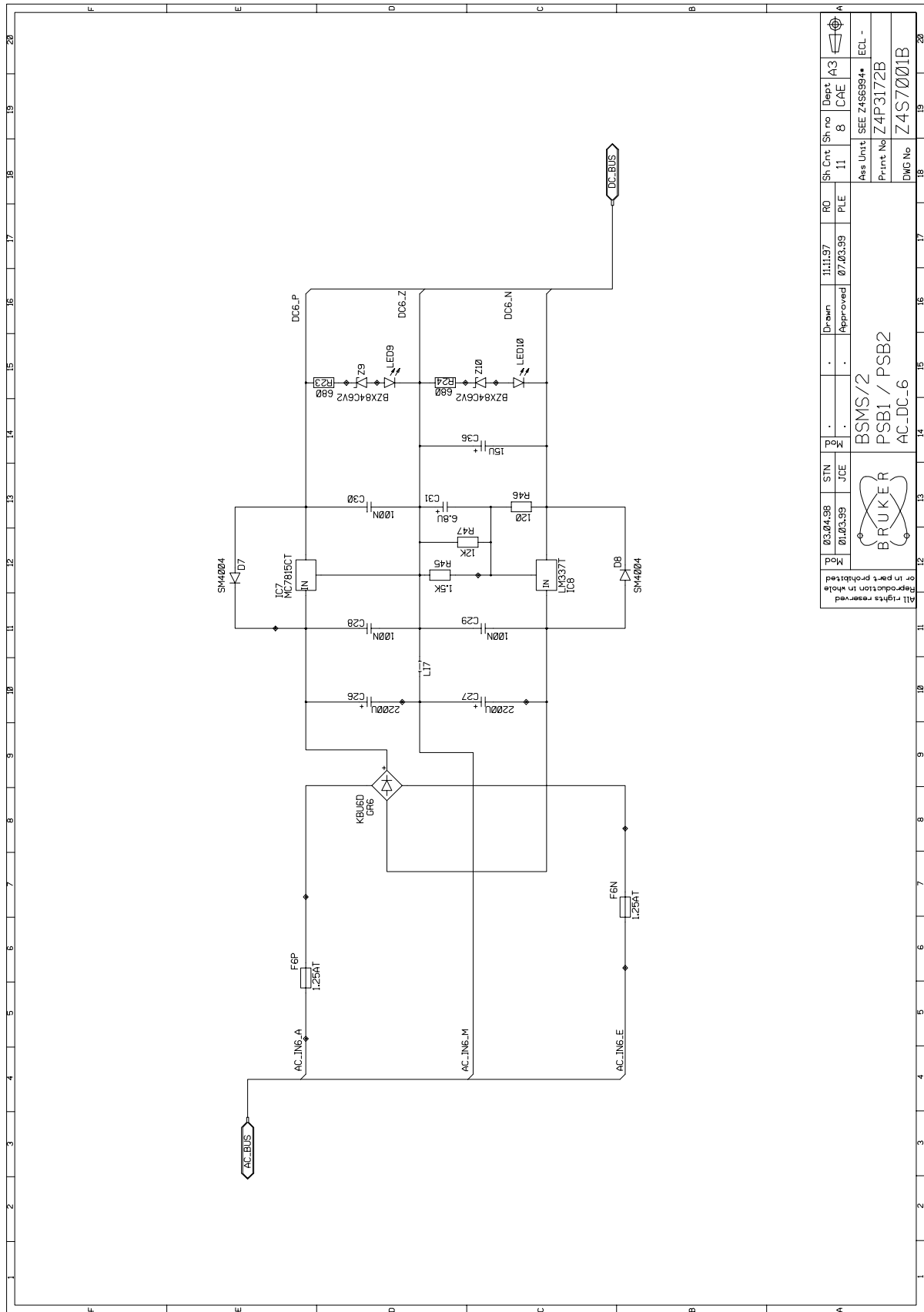

03.04.98	STN	11.11.97	RO	Sh. Cnt	Sh. no	Dept	Ass Unit	Print No	DWG No	
01.03.99	JCE	07.03.99	PLE	11	8	C/AE	SEE Z456994	Z4P3172B	Z4S7001B	
							BSMS/2 PSB1 / PSB2 AC_DC_6			
All rights reserved Reproduction in whole or in part prohibited										

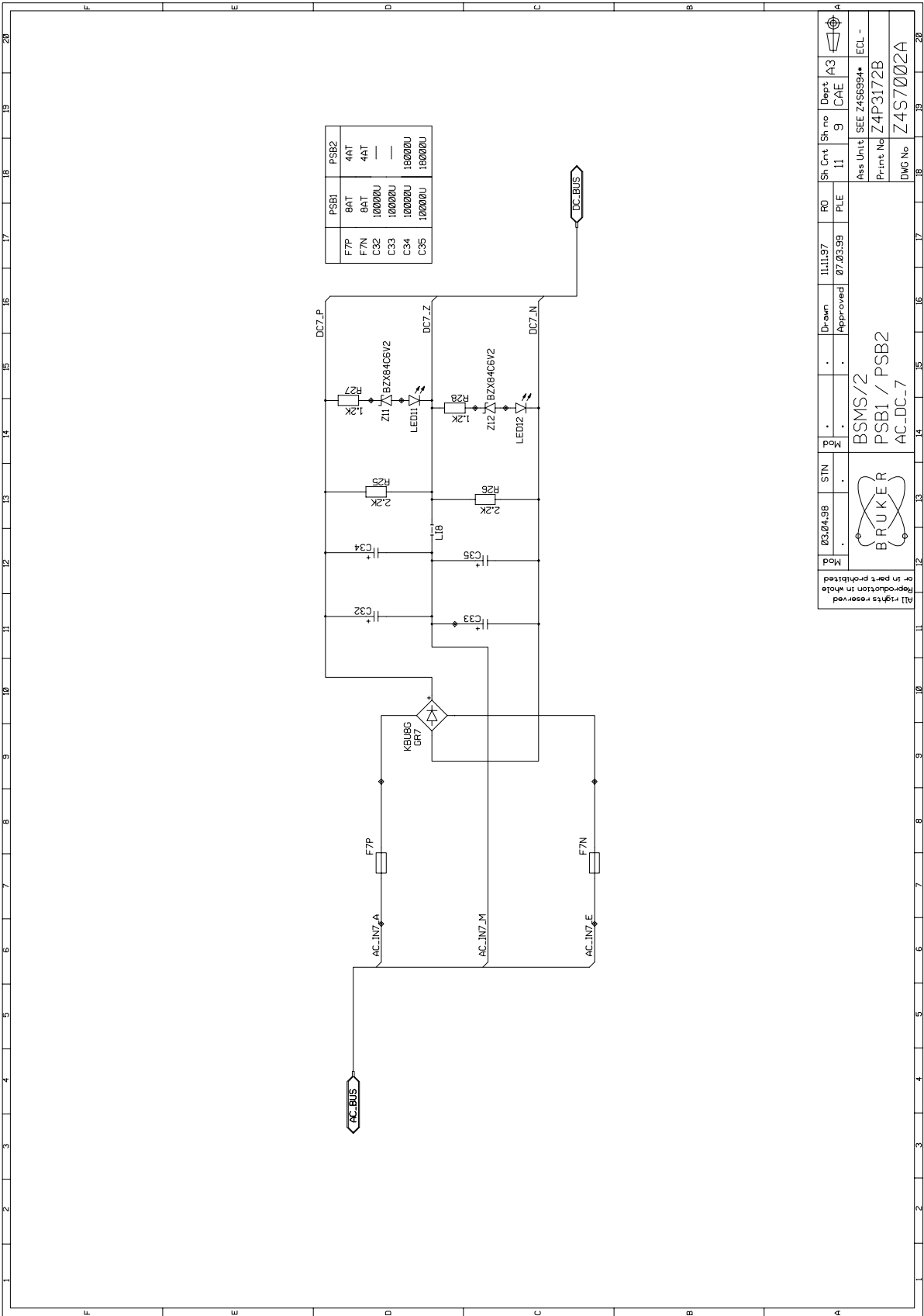

	PSB1	PSB2
F7P	8AT	4AT
F7N	8AT	4AT
C32	100000U	—
C33	100000U	—
C34	100000U	100000U
C35	100000U	100000U

Mod 03,074,9B STN Drawn 11.11.97 RO Sh Cnt Sh no Dept A3
 Approved 07.03.99 PLE 11 9 CAE
 Mod BSM5/2
 BRUKER PSB1 / PSB2 Ass Unit! SEE Z456994* ECL -
 AC-DC-7 Print No Z4P3172B
 DWG No Z4S7002A

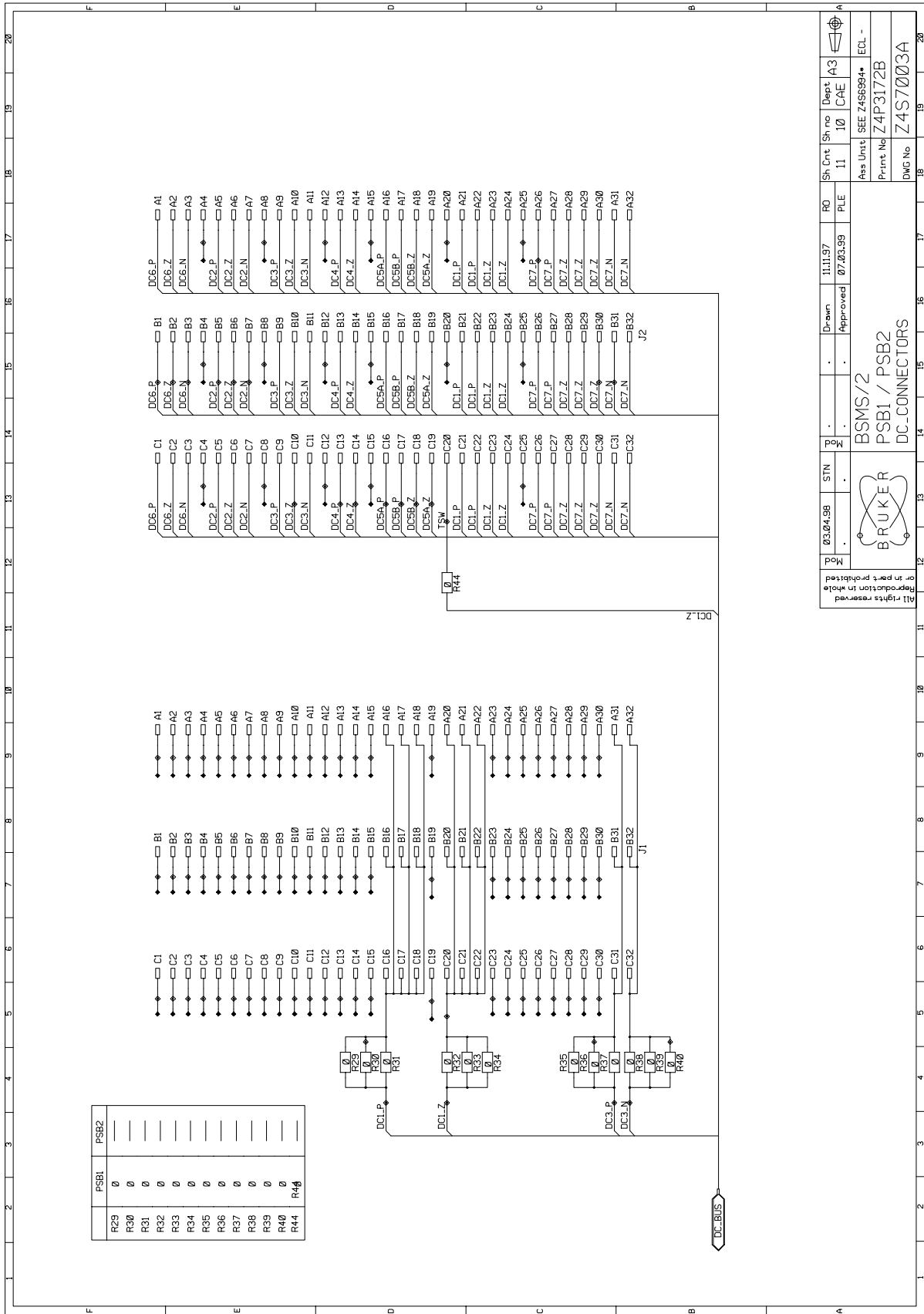

234567891011121314151617181920

FEDCBA

Basic MEC

Pos	Cat. No	Count	Part Name	Value	Note
MEC1	Z13611	1	PCB	Z4P3172B	
MEC3	Z95532	5	BFEL DISTBOLZ M3X10 AIG MSNI		
MEC4	8776	1	GEH ZUB KARTENGRIFF ROT		
MEC5	Z95666	2	BFEL LINSCHR KR M2,5X6 V2A		
MEC6	Z9572	5	BFEL LINSCHR KR M3X6 V2A		
MEC7	Z9648	4	BFEL RUHRRIEPE 2,5X0,3X3,5 MS		
MEC8	Z13627	1	BSMS/2 KUEHLKOEPPER PSB		
MEC9	Z9575	7	BFEL LINSCHR KR M3X12 V2A		
MEC10	Z9581	7	BFEL FAECHERSCHEIBE M3 V2A		
MEC11	1841	1	TRANS ZUB WAERMELEITTS. T0218		
MEC17	11187	6	BFEL USCHEIBE M3 V2A		

Variant PSB1

MEC12	45277	9	SICHTHALTER 5X20 SMD		
MEC13	Z13628	1	SCHILD PL WS PSB1		
MEC14	Z1486	4	TRANS ZUB WAERMELEITTS. T0220		
MEC15	7348	4	TRANS ZUB ISOLBUCHSE FUER M3		
MEC16	Z9572	4	BFEL LINSCHR KR M3X6 V2A		

Variant PSB2

MEC12	45277	10	SICHTHALTER 5X20 SMD		
MEC13	Z13629	1	SCHILD PL WS PSB2		
MEC14	Z1486	7	TRANS ZUB WAERMELEITTS. T0220		
MEC15	7348	7	TRANS ZUB ISOLBUCHSE FUER M3		
MEC16	Z9572	7	BFEL LINSCHR KR M3X6 V2A		

LABEL_SER
 SERIEN/TEIL/NR
 2774

LABEL_ICT
 ICT-BARC
 ICT-BARCODE

STAMP_ORDER
 ORDER
 ORDER-NUMBER

STAMP_MAN
 MAN
 MANUFACTURER CODE

STAMP_ICT
 ICT
 ICT-STAMP

Mtd	Ø3.04.98	STN	JCE	FAL	Drown	12.11.97	RO	Sh. Cnt	Sh. no	Dept	A3
	Ø1.03.99				Approved	15.07.99	PLE	11	11	CAE	
BSMS/2											
PSB1 / PSB2											
Mechanical Parts											
Ass Unit SEE Z4S6994* ECL - Print No Z4P3172B DWG No Z4S7004C											

FIDUCIAL
 FIDU1

FIDUCIAL
 FIDU2

