

BLAX1000

Amplifier 30-325MHz Technical Manual

Version 002

BRUKER

The information in this manual may be altered without notice.

BRUKER accepts no responsibility for actions taken as a result of use of this manual. BRUKER accepts no liability for any mistakes contained in the manual, leading to coincidental damage, whether during installation or operation of the instrument. Unauthorised reproduction of manual contents, without written permission from the publishers, or translation into another language, either in full or in part, is forbidden.

This manual was written by

OTT Charles

© June 9, 1998: Sadis Bruker Spectrospin

Wissembourg, France

Manual P/N: Z31440

DWG-Nr: 1150002

Contents

	Contents	3
	Index	5
1	General description	7
1.1	Introduction	7
1.2	Description of the Unit	7
1.3	Characteristics	7
1.4	Wiring	8
2	BLAX1000 Amplifier 30-325MHz	9
3	BLAX1010 Option HR.....	11
4	BLMX1000 RF Amplifier Module 30-325MHz	13
5	BDCX46 Coupler	39
6	BDCX40 Coupler	43
7	BLA Control Board 2	47
8	BLA Control Board Extension	67
9	BLA SBS Bus Controller	73
10	Status Led Board	85
11	Fan Status Board	91
12	Supply Status Driver	95
13	Power Supply Terminal.....	99
14	Specifications	103
14.1	Common Characteristics	103
14.2	RF Pulsed Amplifier BLAX1000 / 30-325 MHz specifications ..	

Contents

14.3	104	
	Power Supply specifications	105
	Figures	107
	Tables	109

Index

W

W4B132166 A.....	15
W4B132167 A.....	19
W4B132169 A.....	10
W4B132170 A.....	14
W4B132215.....	30
W4B132485.....	12
W4D131693 A.....	57
W4D132154.....	70
W4L131378.....	87
W4L131402 B.....	48
W4L131403 B.....	49
W4L131508.....	24
W4L131837.....	78
W4L132050 A.....	93
W4L132139 A.....	97
W4L132153 A.....	69
W4L132168 A.....	27
W4L132215.....	32
W4S131378.....	86
W4S131402 B.....	50
W4S131403 B.....	51
W4S131404 B.....	52
W4S131405 B.....	53
W4S131406 B.....	54
W4S131407 B.....	55
W4S131408 B.....	56
W4S131508.....	23
W4S131716 A.....	44
W4S131837 F.....	74
W4S131838 F.....	75
W4S131839 F.....	76
W4S131840 F.....	77
W4S132050 A.....	92
W4S132118.....	40
W4S132135.....	34
W4S132136.....	36
W4S132139 A.....	96
W4S132141.....	100
W4S132153 B.....	68
W4S132166 A.....	16
W4S132167 A.....	20
W4S132168 A.....	26
W4S132215.....	31
W4W131557.....	83
W4W131580.....	89
W4W131582.....	65

W4W132256 66

General description

1

Introduction

1.1

The linear amplifier BLMX1000 / 30-325MHz (P/N:W1345029) is intended to equip the BRUKER Solid NMR spectrometers type AVANCE DSX 750MHz and DSX 800MHz.

This amplifier is built in the same way as the BLAX1000 / 6-243MHz, only the power module RF BLMX (P/N:W1345154) is different.

The amplifier is furthermore fitted with a high resolution output X300 in the basis version.

Description of the Unit

1.2

The amplifier is mounted in a rack 19" x 4U x 580mm and is fitted with following sub-assemblies:

1. An RF power module	BLMX1000	W1345154
2. A coupler	BDCX46	W1346041
3. A coupler	BDCX40	W1346018
4. A control board	BLA CONTROL	W1301861
5. A controller	SBS BUS CONTROLLER	H5245
6. A status display	STATUS BOARD	W1301877
7. A power supply control board	SUPPLY STATUS BOARD	W1346052
8. A fan control board	FAN STATUS BOARD	W1301934
9. A HR control board	BLA CONTROL EXT.	W1346066
10. A High Resolution RF relay	X100 / X300	30452

A power supply 4KW (P/N:W1345013) will be added to the BLAX1000 amplifier (P/N:W1345029).

Amplifier BLAX1000 / 30-325MHz + Power Supply 4KW : P/N:W1303178.

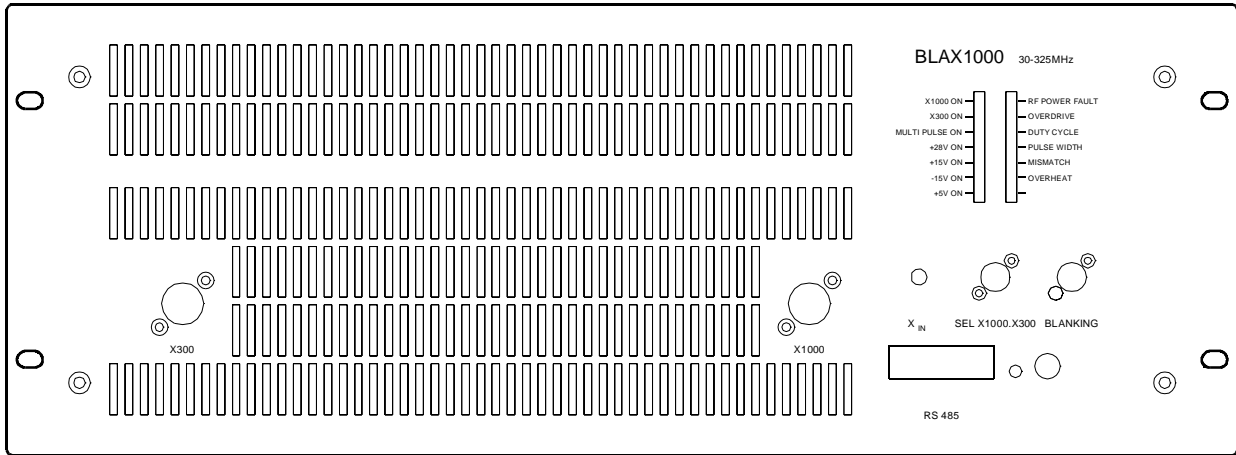
Characteristics

1.3

The characteristics and RF specifications of this amplifier are described in the chapter ("**Specifications**" on page 103), below an excerpt :

Frequency range	30 to 325MHz
Linear gain X1000 / X300	64dB \pm 1dB / 55dB \pm 1dB
Gain flatness X1000 / X300	\pm 3dB / \pm 3dB
Minimum pulse output power X1000	1000W to 200Mhz; 700W to 325MHz
Minimum pulse output power X300	250W full range
Pulse width max. X1000 / X300	100ms at nominal power 1000/300
Duty cycle max. X1000 / X300	5% at nominal power 1000/300

Figure 1.1. Front panel wiring



***BLAX1000 Amplifier
30-325MHz***

2

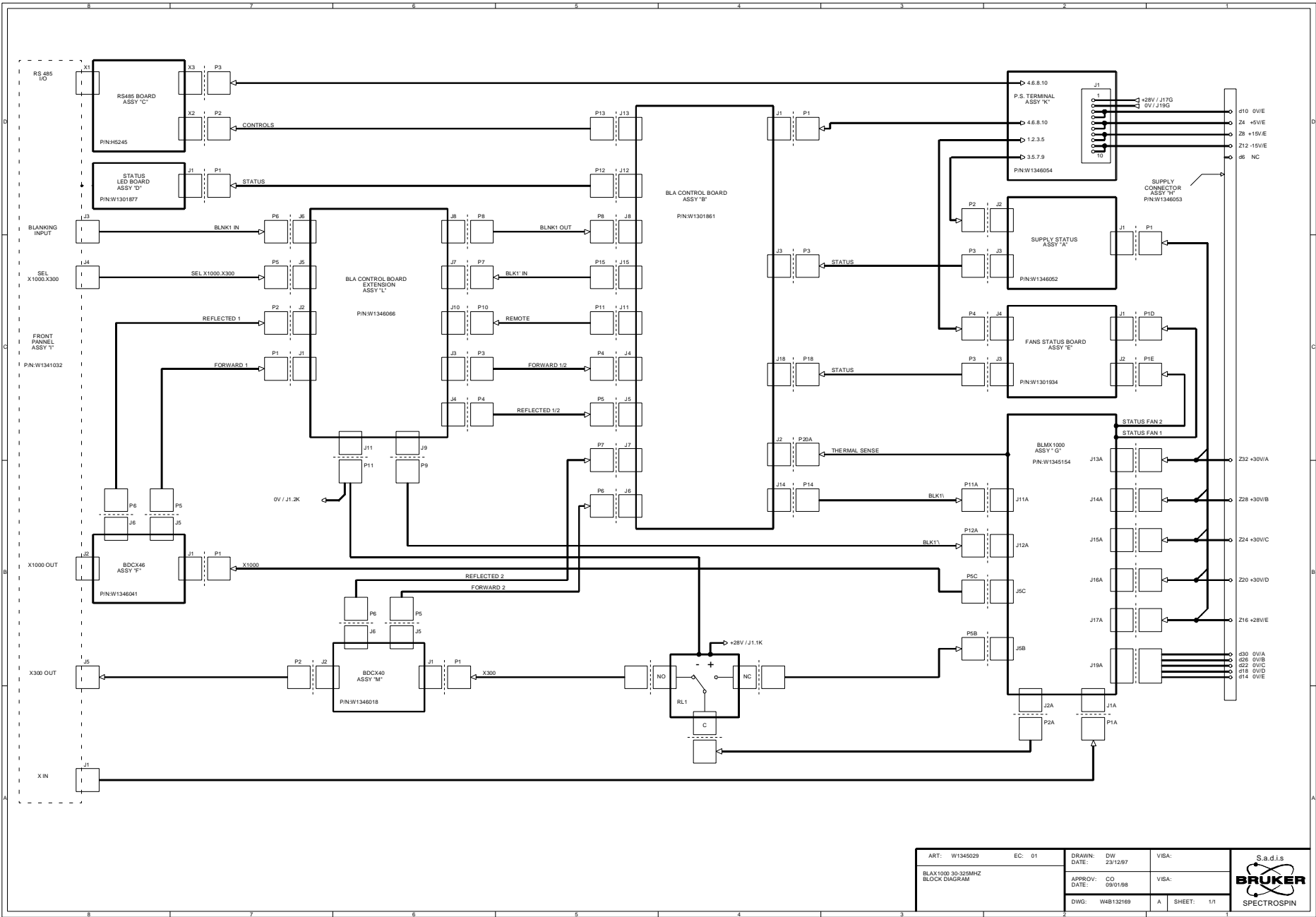


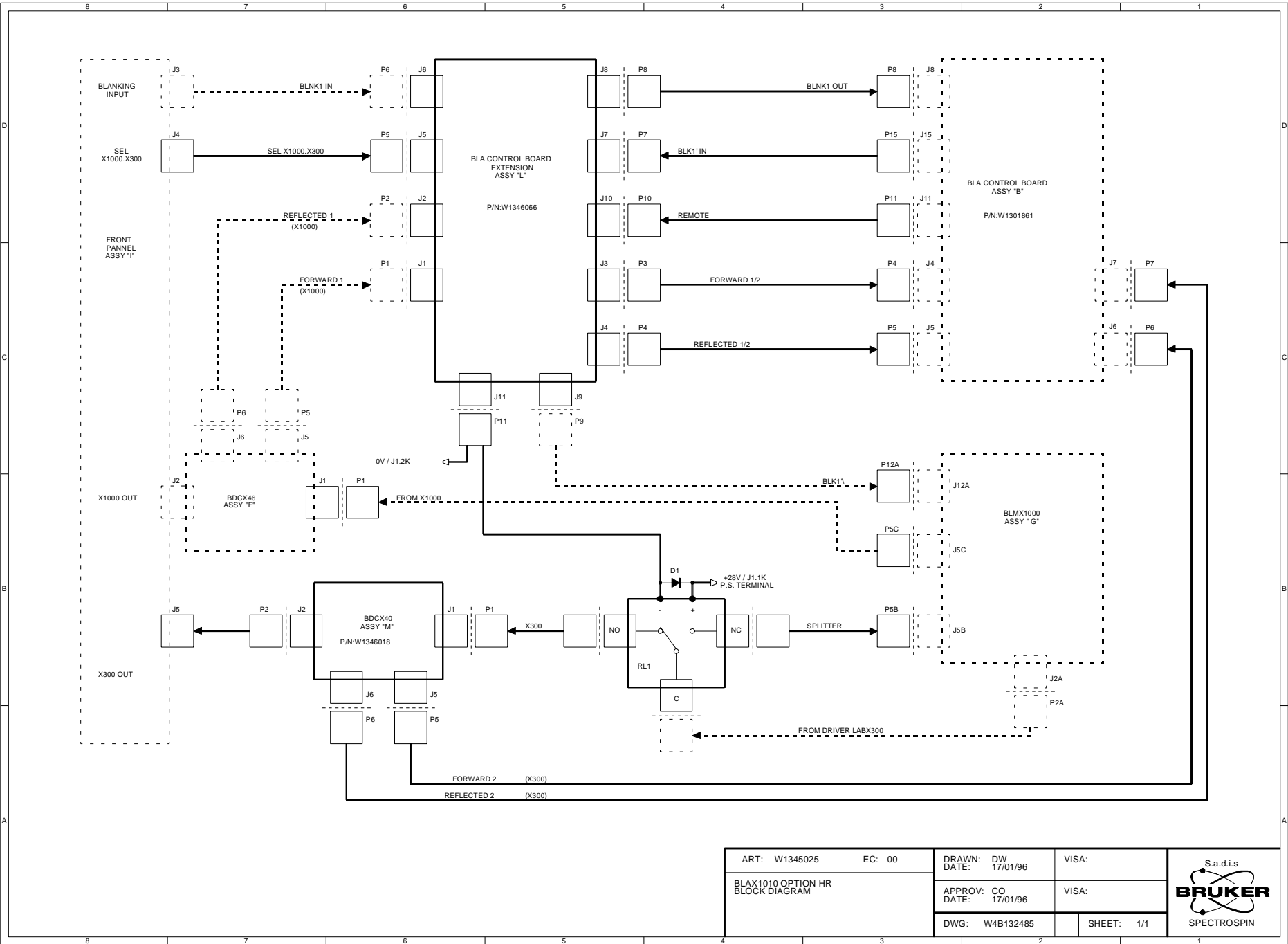
Figure 2.1. BLAX1000 Amplifier 30-325MHz Block Diagram

ART: W1345029	EC: 01	DRAWN: DW 23/12/97	VISA:	
BLAX1000 30-325MHZ BLOCK DIAGRAM		APPROV: CO 09/01/98	VISA:	
		DWG: W48132169	A SHEET: 1/1	

BLAX1010OptionHR

3

Figure 3.1. BLAX1010 Block Diagram



12 (111)

BRUKER

Technical Manual Version 002

ART: W1345025	EC: 00	DRAWN: DW DATE: 17/01/96	VISA:
BLAX1010 OPTION HR BLOCK DIAGRAM		APPROV: CO DATE: 17/01/96	VISA:
		DWG: W4B132485	SHEET: 1/1



***BLMX1000 RF
Amplifier Module 30-
325MHz***

4

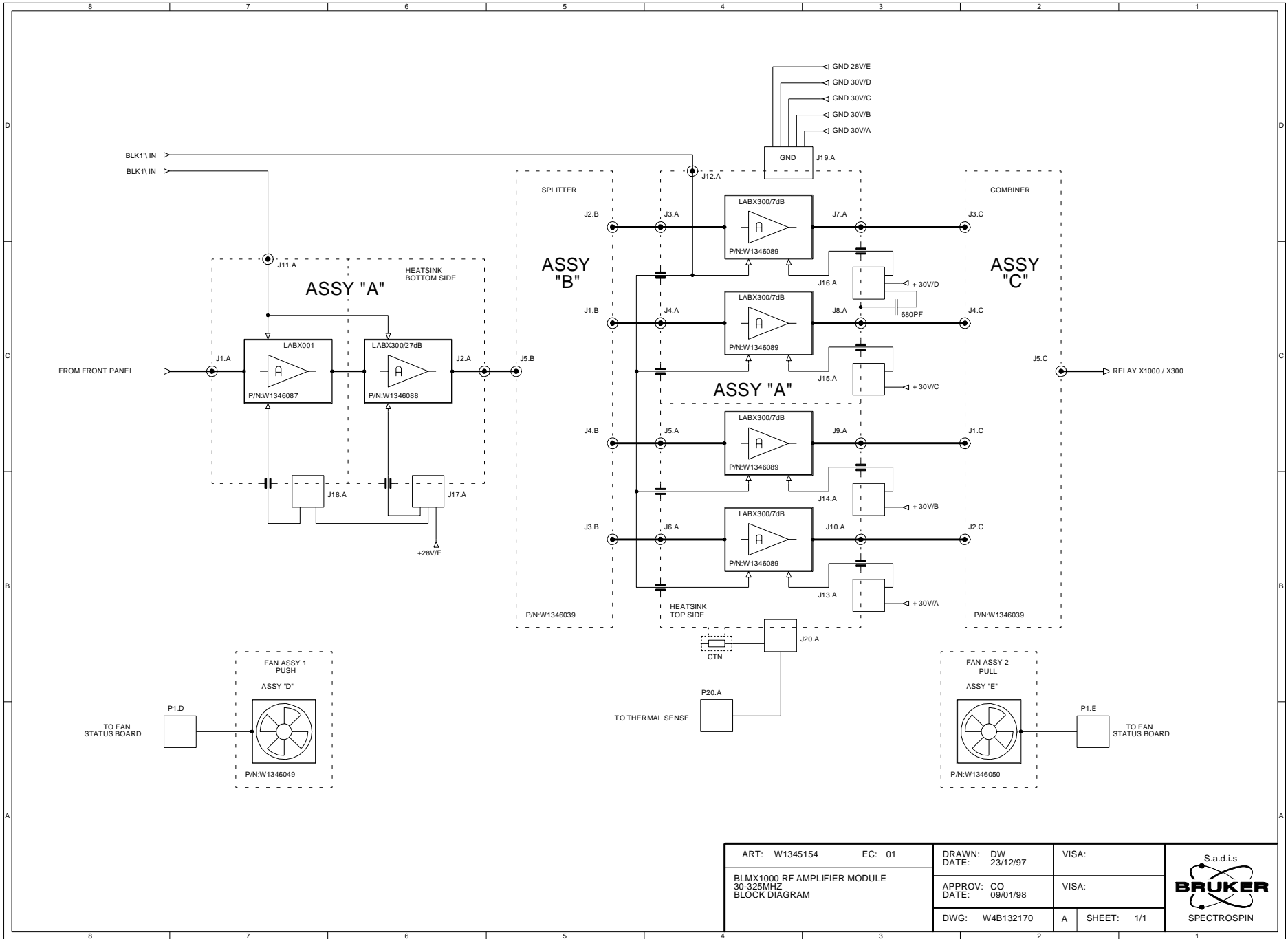


Figure 4.1. BLMX1000 RF Amplifier Module 30-325MHZ Block Diagram

ART: W1345154	EC: 01	DRAWN: DW DATE: 23/12/97	VISA:
BLMX1000 RF AMPLIFIER MODULE 30-325MHZ BLOCK DIAGRAM		APPROV: CO DATE: 09/01/98	VISA:
DWG: W4B132170	A	SHEET: 1/1	



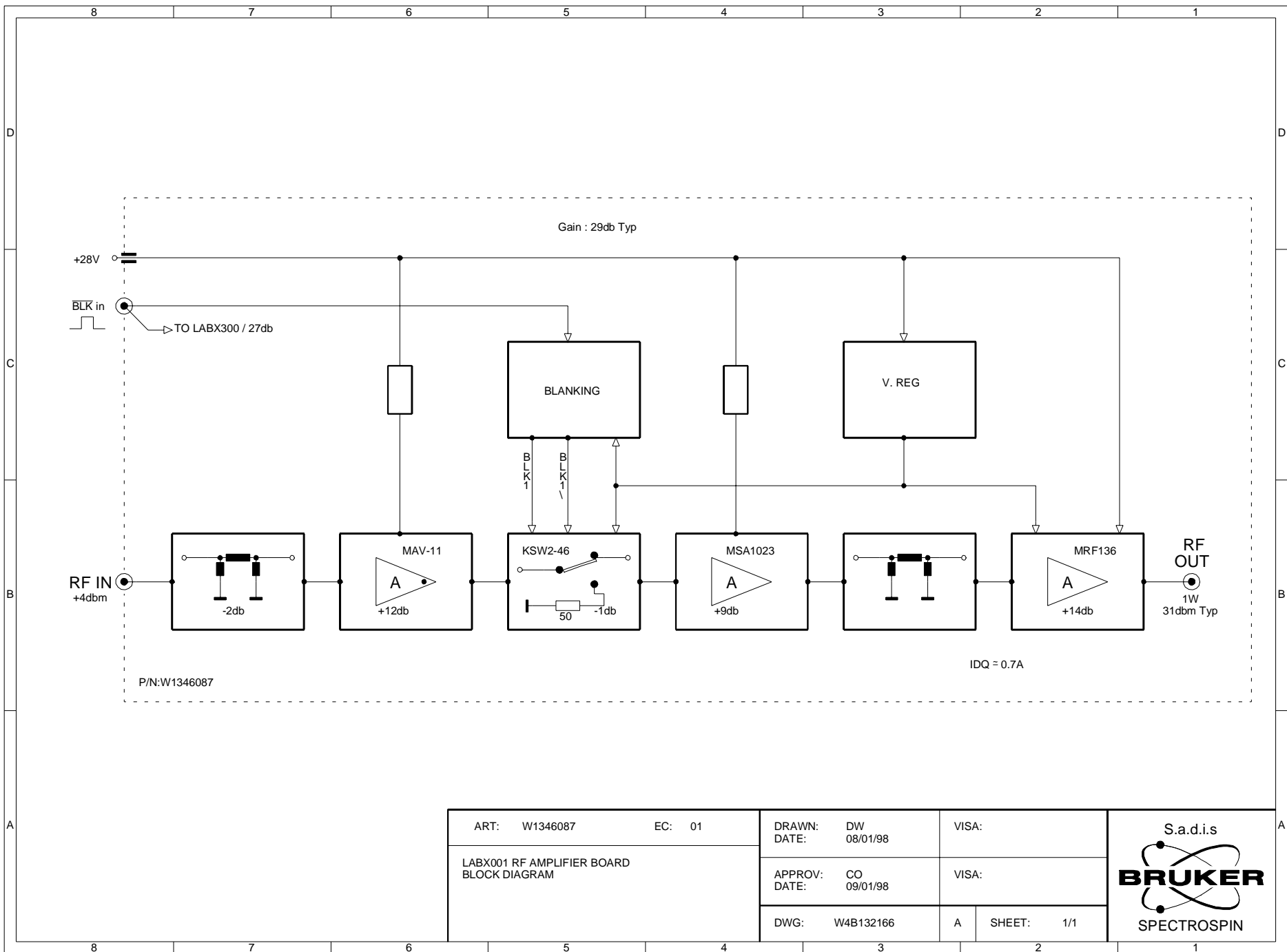


Figure 4.2. LABX001 RF Amplifier Board 30-325MHZ Block Diagram

ART: W1346087	EC: 01	DRAWN: DW	VISA:	
LABX001 RF AMPLIFIER BOARD BLOCK DIAGRAM		DATE: 08/01/98	DATE: 09/01/98	
DWG: W4B132166	A	SHEET: 1/1		

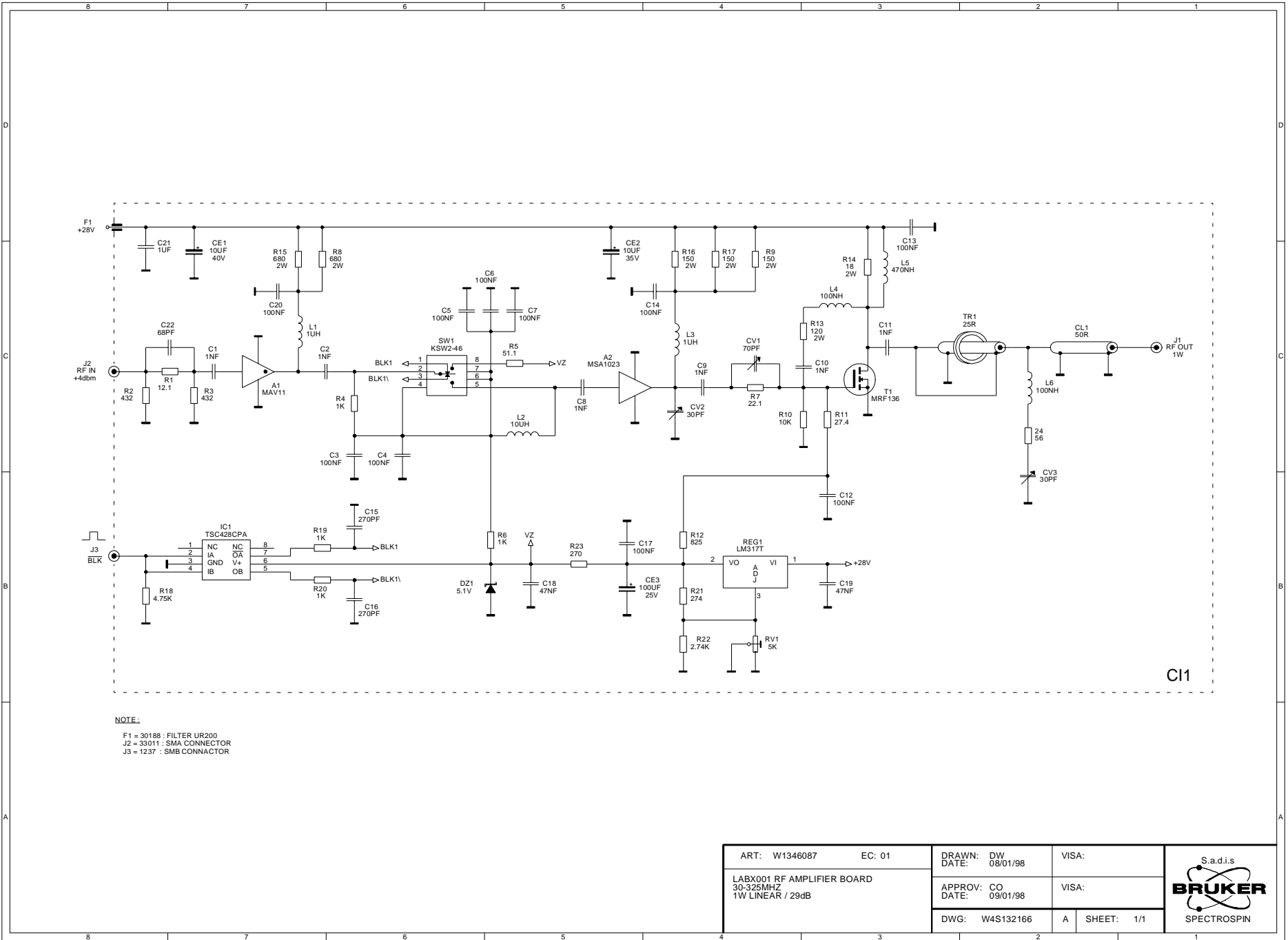


Figure 4.3. LABX001 RF Amplifier Board 30-325MHz Schematic

ART: W1346087	EC: 01	DRAWN: DW DATE: 08/01/98	VISA:	
LABX001 RF AMPLIFIER BOARD 30-325MHZ 1W LINEAR / 29dB		APPROV: CO DATE: 09/01/98	VISA:	
		DWG: W4S132166	A SHEET: 1/1	

Value Table

Part:W1346087 Drawing:W4S132166A		Copy In Part:	Draw:
Desc:CIRCUIT AMPLI RF LABX001		ECL:1	Modified:27/03/97 By:CO
Value Tab			
Pos.	Component	Local Description	
A01	31201	IC 11/HF MAV-11	
A02	56344	AMPLI RF SILICOM BOITI.2302LFL	
C01	30424	COND CMS CDR14 1N 50V 20%	
C02	30424	COND CMS CDR14 1N 50V 20%	
C03	8493	COND CMS 1206 100N 50V 20% X7R	
C04	8493	COND CMS 1206 100N 50V 20% X7R	
C05	8493	COND CMS 1206 100N 50V 20% X7R	
C06	8493	COND CMS 1206 100N 50V 20% X7R	
C07	8493	COND CMS 1206 100N 50V 20% X7R	
C08	30424	COND CMS CDR14 1N 50V 20%	
C09	30424	COND CMS CDR14 1N 50V 20%	
C10	30424	COND CMS CDR14 1N 50V 20%	
C11	30424	COND CMS CDR14 1N 50V 20%	
C12	8493	COND CMS 1206 100N 50V 20% X7R	
C13	8493	COND CMS 1206 100N 50V 20% X7R	
C14	8493	COND CMS 1206 100N 50V 20% X7R	
C15	30417	COND CMS CDR14 270P 200V 20%	
C16	30417	COND CMS CDR14 270P 200V 20%	
C17	8493	COND CMS 1206 100N 50V 20% X7R	
C18	30197	COND CMS 2220 47N 100V SPT695E	
C19	30197	COND CMS 2220 47N 100V SPT695E	
C20	8493	COND CMS 1206 100N 50V 20% X7R	
C21	53242	COND CERM 1U 100V 10% X7R	
C22	30410	COND CMS CDR14 68P 500V 20%	
CE01	56066	COND CHIMI TANTAL 10U 40V AX	
CE02	3746	COND CHIMI RAD 10U 35V 5X7 R5	
CE03	1980	COND CHIMI RAD 100U 25V 6.3X11	
CI01	W1356246	CI BLMX001 PREAMPLI	
CV01	12097	COND VAR PLTSC 5.5-65P 240V	
CV02	3204	COND VAR PLSTC 2-27P 250V D7.5	
CV03	3204	COND VAR PLSTC 2-27P 250V D7.5	
DZ01	30731	DIODE Z BZX85C 5.1V 1.3W	
IC01	56292	IC 428/DRV TSC428CPA DIP8	
ICSU01	4285	IC SUPPORT DIL8 TULIPE	
J01	1242	CN COAX SMB F C SRT 2.6/50 1TR	
L01	30139	SELF 1UH 0.88A	
L02	30155	SELF 10UH 0.14A	
L03	30139	SELF 1UH 0.88A	
L04	30142	SELF 0.10UH 1.38A	
L05	30136	SELF 0.47UH 1.37A	
L06	30142	SELF 0.10UH 1.38A	
R01	20712	RES CMS 12.1 1% 0.25W 1206	
R02	56311	RES CMS 432 1% 0.25W 1206	
R03	56311	RES CMS 432 1% 0.25W 1206	
R04	8888	RES MET 1K 1% 0.5W 50PPM	
R05	20765	RES CMS 51.1 1% 0.25W 1206	
R06	8888	RES MET 1K 1% 0.5W 50PPM	
R07	990	RES MET 22.1 1% 0.6W 50PPM	
R08	6099	RES ACA 680 5% 2W	
R09	2699	RES ACA 150 5% 2W	
R10	1022	RES MET 10K 1% 0.6W 50PPM	
R11	991	RES MET 27.4 1% 0.6W 50PPM	
R12	1009	RES MET 825 1% 0.6W 50PPM	
R13	2698	RES ACA 120 5% 2W	

BLMX1000 RF Amplifier Module 30-325MHz

```

-----+-----
| Part:W1346087 Drawing:W4S132166A          Copy In Part:          Draw:          |
| Desc:CIRCUIT AMPLI RF LABX001            ECL:1          Modified:27/03/97    By:CO      |
+-- Value Tab -----+-----
| Pos.          Component          Local Description          |
| R14           2619                RES CCA 18 5% 2W          |
| R15           6099                RES ACA 680 5% 2W        |
| R16           2699                RES ACA 150 5% 2W        |
| R17           2699                RES ACA 150 5% 2W        |
| R18           1018                RES MET 4.75K 1% 0.6W 50PPM |
| R19           8888                RES MET 1K 1% 0.5W 50PPM  |
| R20           8888                RES MET 1K 1% 0.5W 50PPM  |
| R21           1003                RES MET 274 1% 0.6W 50PPM |
| R22           1015                RES MET 2.74K 1% 0.6W 50PPM |
| R23           20729               RES CMS 270 1% 0.25W 1206 |
| R24           31606               RES CCA 56 5% 1W          |
| REG01         452                 IC 317/VREG LM317T TO220   |
| RV01          34809               RES AJUST 5K 0.5W 25T V    |
| SW01          16192               DIODE PIN SW ASGA CMS DC-5GHZ |
| T01           30043               TRANS MRF136 NFET 211-07 28V |
| TR01          W1356385            TRSFO TORE 25R 1X3SP 90MM  |
+-----+-----

```

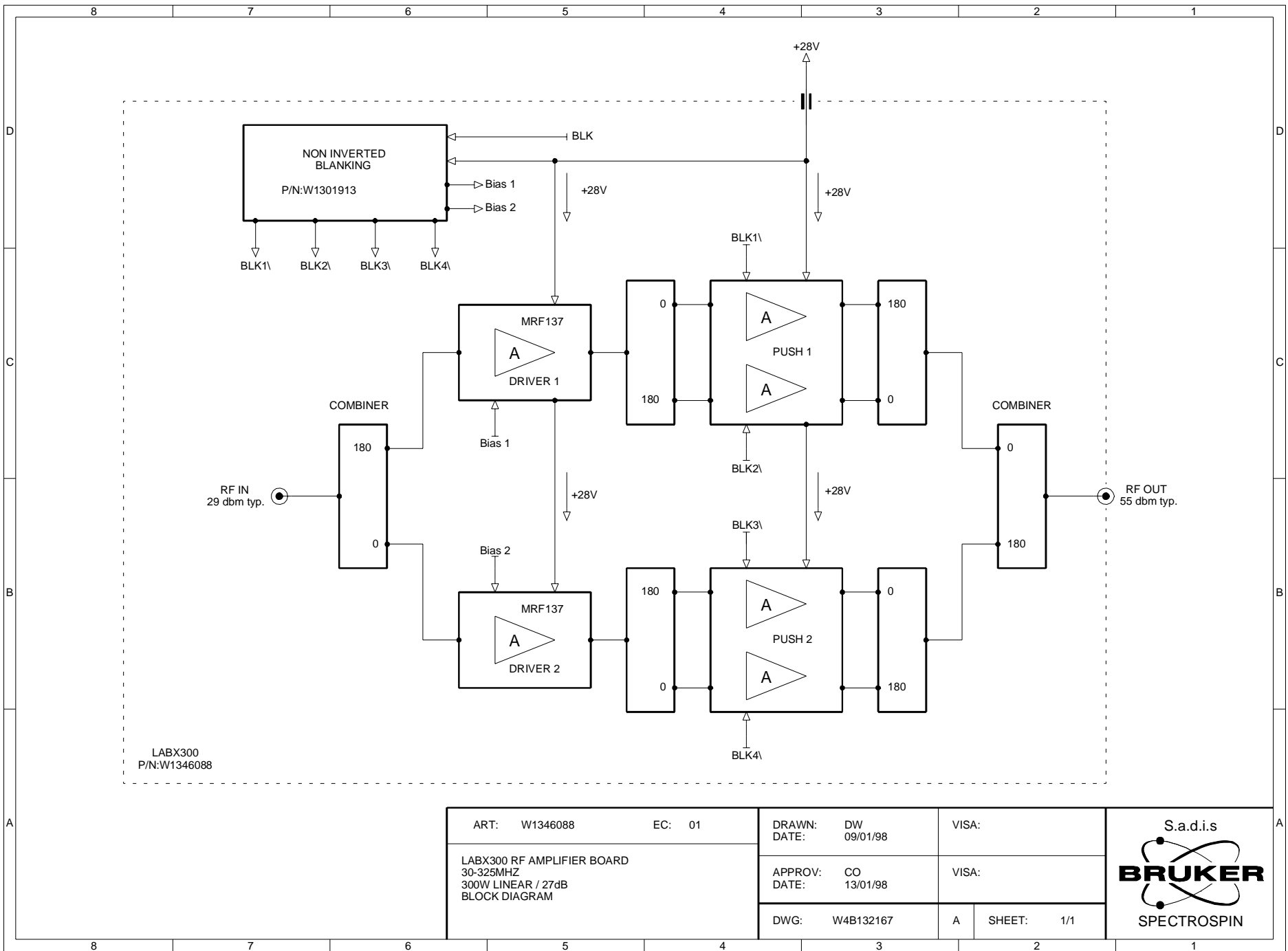
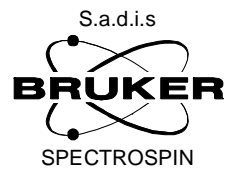
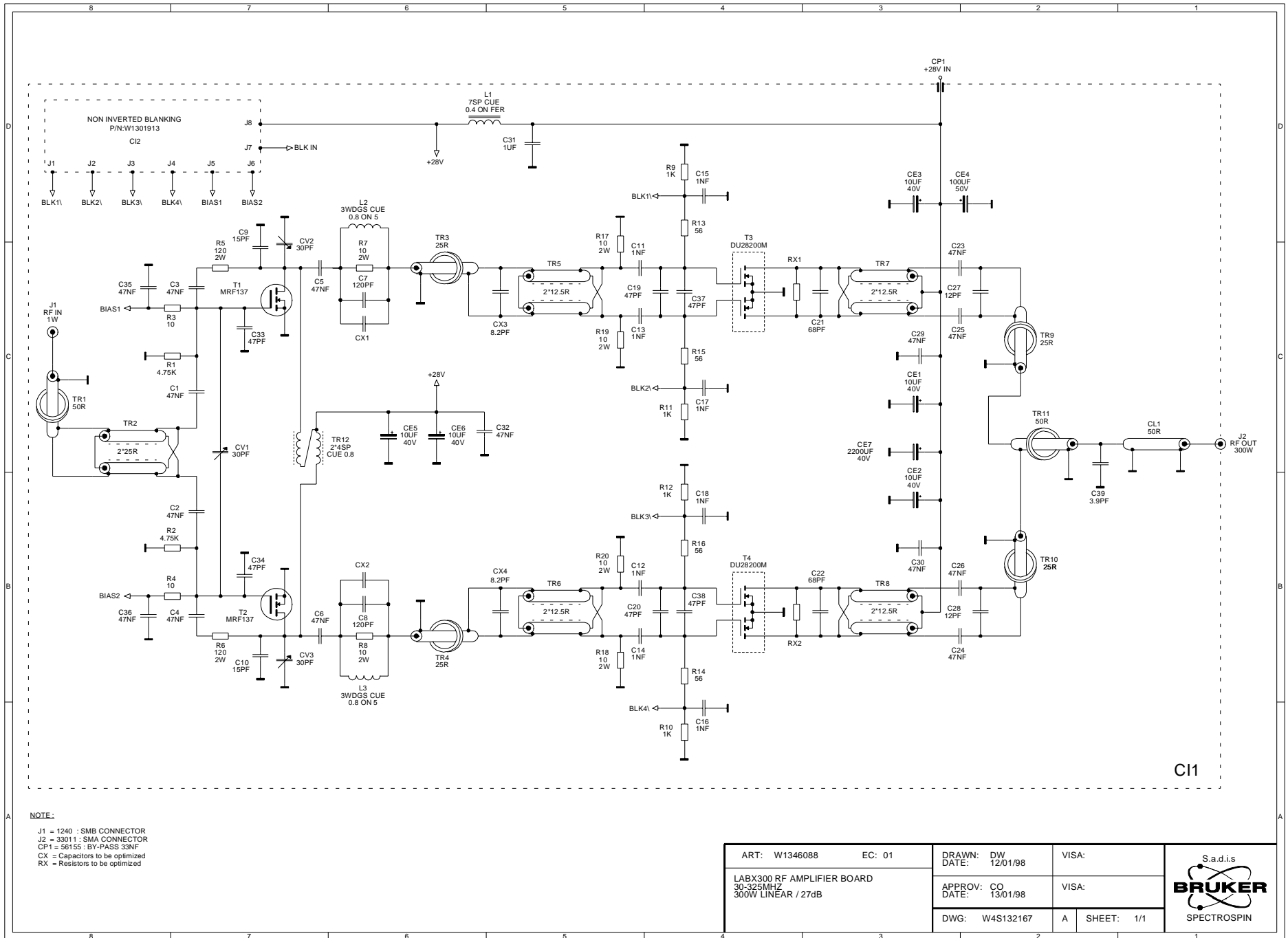


Figure 4.4. LABX300 RF Amplifier Board 30-325MHZ / 27dB Block Diagram





NOTE:

- J1 = 1240 : SMB CONNECTOR
- J2 = 33011 : SMA CONNECTOR
- CP1 = 56155 : BY-PASS 33NF
- CX = Capacitors to be optimized
- RX = Resistors to be optimized

ART: W1346088	EC: 01	DRAWN: DW DATE: 12/01/98	VISA:	
LABX300 RF AMPLIFIER BOARD 30-325MHZ 300W LINEAR / 27dB		APPROV: CO DATE: 13/01/98	VISA:	
		DWG: W4S132167	A SHEET: 1/1	

Figure 4.5. LABX300 RF Amplifier Board 30-325MHZ / 27dB Schematic

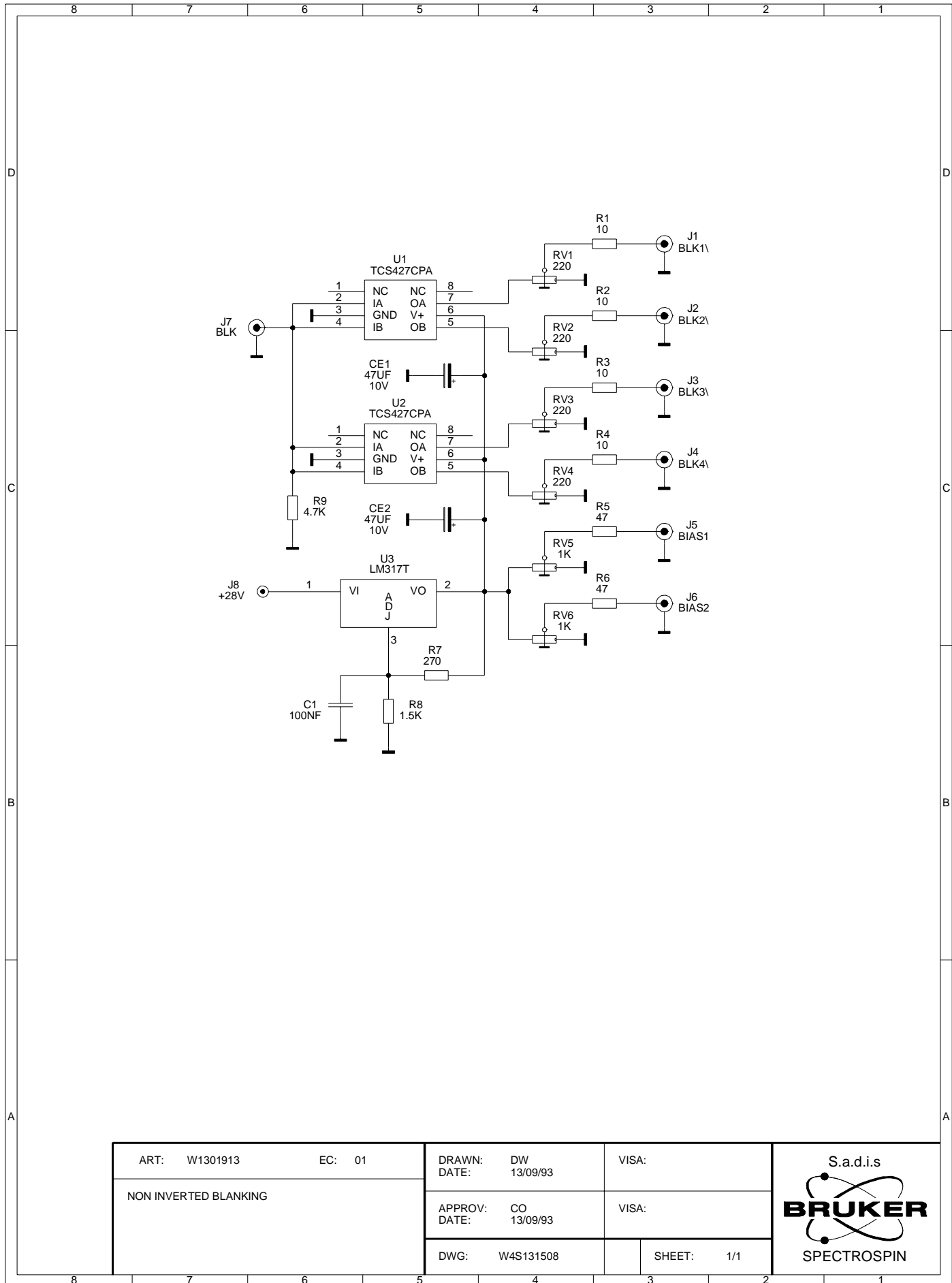
Value Table

Part:W1346088 Drawing:W4S132167A		Copy In Part:		Draw:
Desc:CIRCUIT AMPLI RF LABX300		ECL:1	Modified:02/04/97	By:CO
Value Tab				
Pos.	Component	Local Description		
C01	30197	COND CMS 2220 47N 100V SPT695E		
C02	30197	COND CMS 2220 47N 100V SPT695E		
C03	30197	COND CMS 2220 47N 100V SPT695E		
C04	30197	COND CMS 2220 47N 100V SPT695E		
C05	30197	COND CMS 2220 47N 100V SPT695E		
C06	30197	COND CMS 2220 47N 100V SPT695E		
C07	30413	COND CMS CDR14 120P 300V 20%		
C08	30413	COND CMS CDR14 120P 300V 20%		
C09	30402	COND CMS CDR14 15P 500V 20%		
C10	30402	COND CMS CDR14 15P 500V 20%		
C11	30424	COND CMS CDR14 1N 50V 20%		
C12	30424	COND CMS CDR14 1N 50V 20%		
C13	30424	COND CMS CDR14 1N 50V 20%		
C14	30424	COND CMS CDR14 1N 50V 20%		
C15	30424	COND CMS CDR14 1N 50V 20%		
C16	30424	COND CMS CDR14 1N 50V 20%		
C17	30424	COND CMS CDR14 1N 50V 20%		
C18	30424	COND CMS CDR14 1N 50V 20%		
C19	30408	COND CMS CDR14 47P 500V 20%		
C20	30408	COND CMS CDR14 47P 500V 20%		
C21	30410	COND CMS CDR14 68P 500V 20%		
C22	30410	COND CMS CDR14 68P 500V 20%		
C23	30197	COND CMS 2220 47N 100V SPT695E		
C24	30197	COND CMS 2220 47N 100V SPT695E		
C25	30197	COND CMS 2220 47N 100V SPT695E		
C26	30197	COND CMS 2220 47N 100V SPT695E		
C27	30401	COND CMS CDR14 12P 500V 20%		
C28	30401	COND CMS CDR14 12P 500V 20%		
C29	30197	COND CMS 2220 47N 100V SPT695E		
C30	30197	COND CMS 2220 47N 100V SPT695E		
C31	53242	COND CERM 1U 100V 10% X7R		
C32	30197	COND CMS 2220 47N 100V SPT695E		
C33	30408	COND CMS CDR14 47P 500V 20%		
C34	30408	COND CMS CDR14 47P 500V 20%		
C35	30424	COND CMS CDR14 1N 50V 20%		
C36	30424	COND CMS CDR14 1N 50V 20%		
C37	30408	COND CMS CDR14 47P 500V 20%		
C38	30408	COND CMS CDR14 47P 500V 20%		
C39	30395	COND CMS CDR14 3.9P 500V 0.25P		
CE01	56066	COND CHIMI TANTAL 10U 40V AX		
CE02	56066	COND CHIMI TANTAL 10U 40V AX		
CE03	56066	COND CHIMI TANTAL 10U 40V AX		
CE04	1985	COND CHIMI RAD 100U 50V 8X11.5		
CE05	56066	COND CHIMI TANTAL 10U 40V AX		
CE06	56066	COND CHIMI TANTAL 10U 40V AX		
CE07	374	COND CHIMI AX 2200U 40V 18X30		
CI01	W1340011	CI LABX300 AMPLIFICATEUR		
CI02	W1301913	BLANKING NON INVERSE		
CV01	3204	COND VAR PLSTC 2-27P 250V D7.5		
CV02	3204	COND VAR PLSTC 2-27P 250V D7.5		
CV03	3204	COND VAR PLSTC 2-27P 250V D7.5		
CX03	30399	COND CMS CDR14 8.2P 500V 0.25P		
CX04	30399	COND CMS CDR14 8.2P 500V 0.25P		
J01	1240	CN COAX SMB M C PRT		

BLMX1000 RF Amplifier Module 30-325MHz

Part:W1346088 Drawing:W4S132167A		Copy In Part:	Draw:
Desc:CIRCUIT AMPLI RF LABX300		ECL:1	Modified:02/04/97 By:CO
Value	Tab		
Pos.	Component	Local Description	
L01	W1356381	SELF 7SP/FERRITE D5MM CUE D0.4	
L02	W1356378	SELF 3SP/D5MM CUE D0.8MM	
L03	W1356378	SELF 3SP/D5MM CUE D0.8MM	
R01	1018	RES MET 4.75K 1% 0.6W 50PPM	
R02	1018	RES MET 4.75K 1% 0.6W 50PPM	
R03	2591	RES CCA 10 5% 1W	
R04	2591	RES CCA 10 5% 1W	
R05	2698	RES ACA 120 5% 2W	
R06	2698	RES ACA 120 5% 2W	
R07	6090	RES ACA 10 5% 2W	
R08	6090	RES ACA 10 5% 2W	
R09	1010	RES MET 1K 1% 0.6W 50PPM	
R10	1010	RES MET 1K 1% 0.6W 50PPM	
R11	1010	RES MET 1K 1% 0.6W 50PPM	
R12	1010	RES MET 1K 1% 0.6W 50PPM	
R13	31606	RES CCA 56 5% 1W	
R14	31606	RES CCA 56 5% 1W	
R15	31606	RES CCA 56 5% 1W	
R16	31606	RES CCA 56 5% 1W	
R17	6090	RES ACA 10 5% 2W	
R18	6090	RES ACA 10 5% 2W	
R19	6090	RES ACA 10 5% 2W	
R20	6090	RES ACA 10 5% 2W	
T01	30044	TRANS MRF137 NFET 211-07 28V	
T02	30044	TRANS MRF137 NFET 211-07 28V	
T03	56514	TRANS DU28200 HF MOSFET 200W175	
T04	56514	TRANS DU28200 HF MOSFET 200W175	
TR01	W1356644	TRSFO TORE 50R 1X3SP 115MM	
TR02	W1356555	TRSFO TORE 25R 2X2SP 80MM	
TR03	W1356556	TRSFO TORE 25R 1X3SP 115MM	
TR04	W1356556	TRSFO TORE 25R 1X3SP 115MM	
TR05	W1356557	TRSFO TORE 12.5R 2X2SP 80MM	
TR06	W1356557	TRSFO TORE 12.5R 2X2SP 80MM	
TR07	W1356558	TRSFO TORE 12.5R 2X3SP 135MM	
TR08	W1356558	TRSFO TORE 12.5R 2X3SP 135MM	
TR09	W1356559	TRSFO TORE 25R 1X5SP 190MM	
TR10	W1356559	TRSFO TORE 25R 1X5SP 190MM	
TR11	W1356352	TRSFO TORE 50R 1X4SP 250MM	
TR12	W1356377	TRSFO TORE 2X4SP CUE D0.8MM	

Figure 4.6. Non Inverted Blanking Schematic



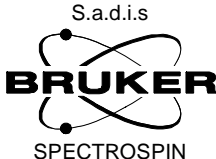
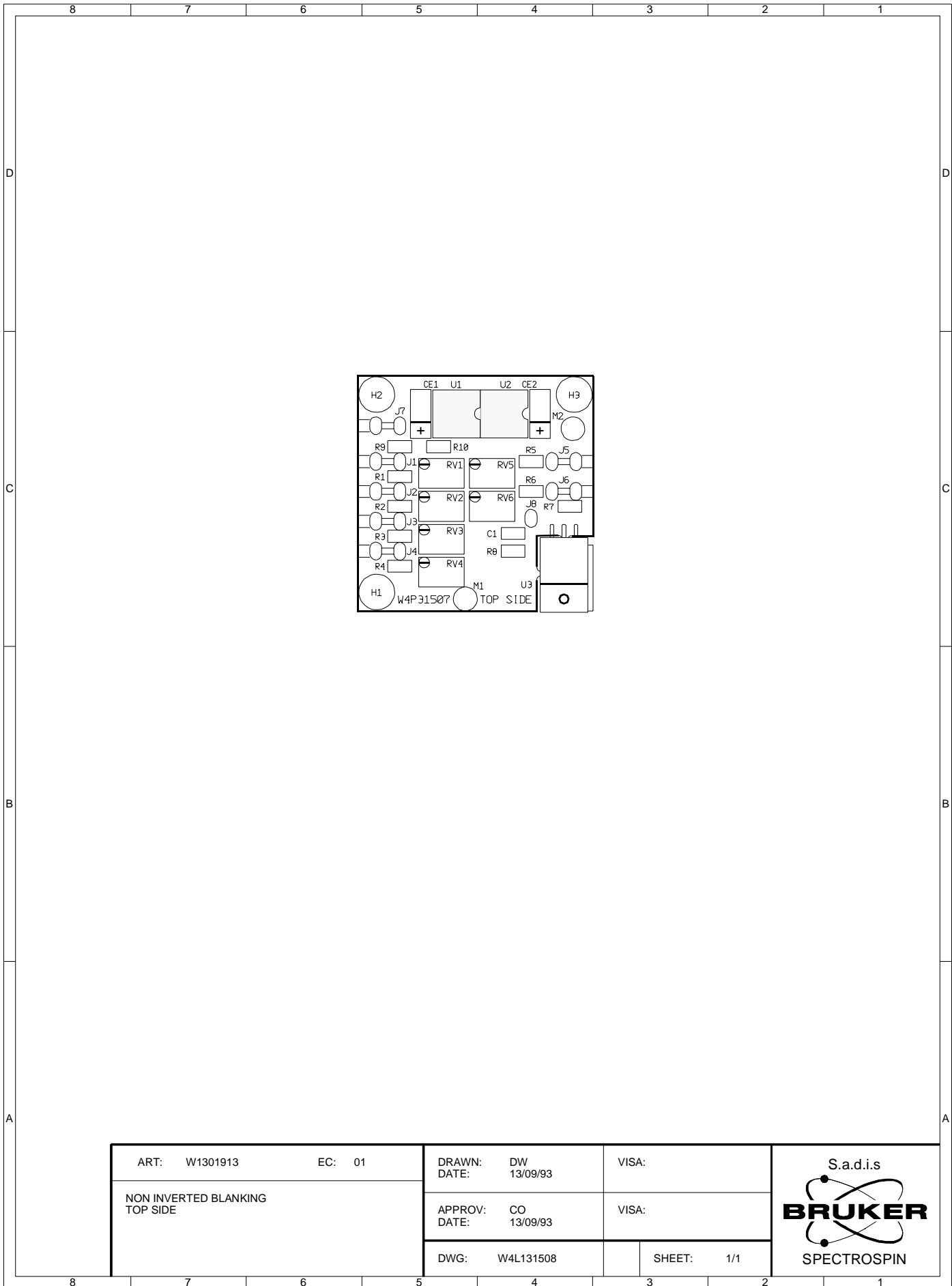
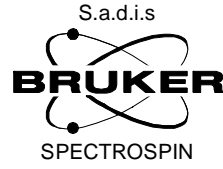
ART: W1301913	EC: 01	DRAWN: DW DATE: 13/09/93	VISA:	
NON INVERTED BLANKING		APPROV: CO DATE: 13/09/93	VISA:	
		DWG: W4S131508	SHEET: 1/1	

Figure 4.7. Non Inverted Blanking Location



ART: W1301913	EC: 01	DRAWN: DW	DATE: 13/09/93	VISA:
NON INVERTED BLANKING TOP SIDE		APPROV: CO	DATE: 13/09/93	VISA:
		DWG: W4L131508	SHEET: 1/1	

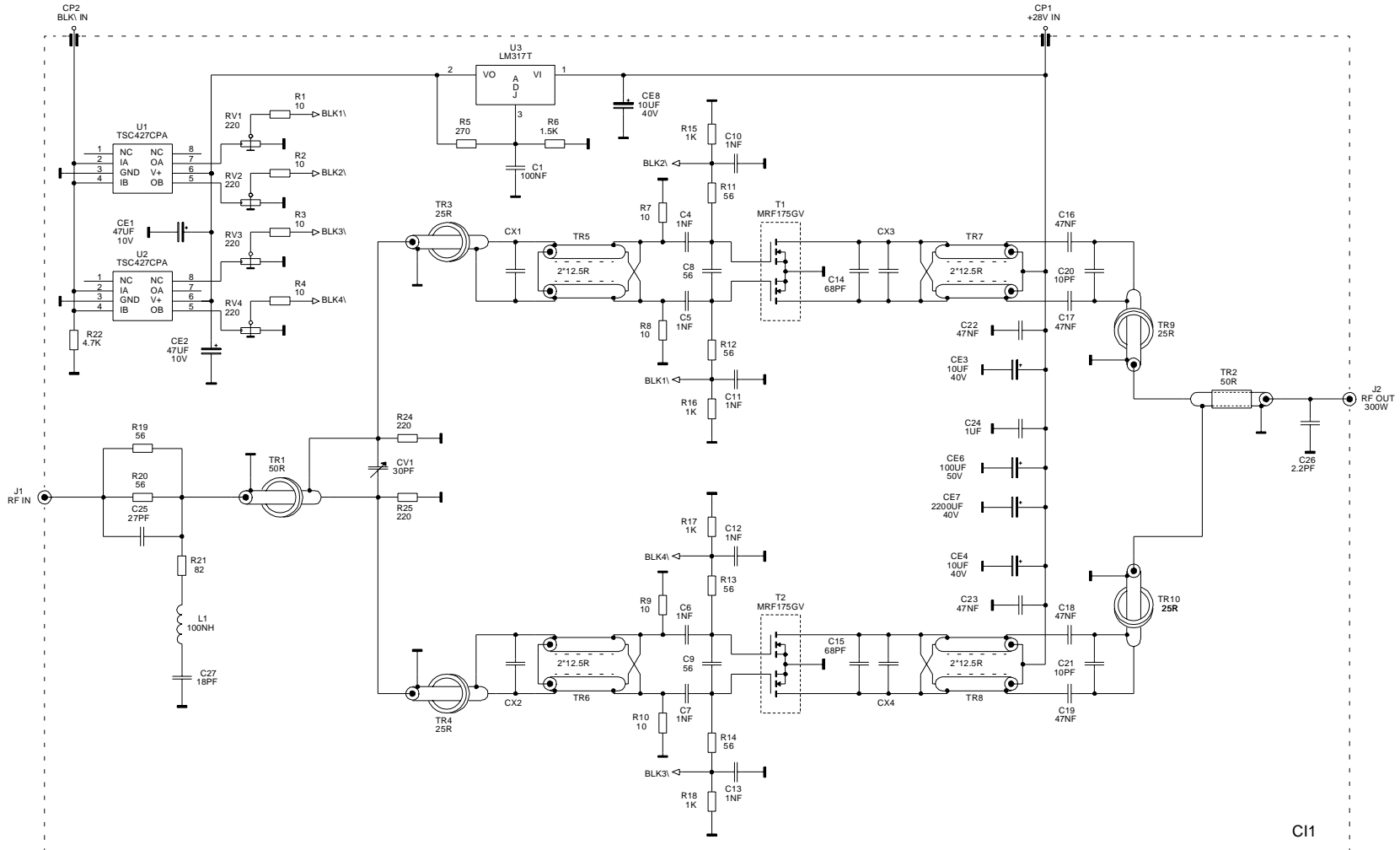


Value Table

```

+-- Value Tab Head -----+
| Part:W1301913 Drawing:W4S131508          Copy In Part:          Draw:          |
| Desc:BLANKING NON INVERSE                ECL:1          Modified:09/05/96      By:DW      |
+-- Value Tab -----+
|      Pos.          Component          Local Description          |
|      C01           8493              COND CMS 1206 100N 50V 20% X7R |
|      CE01          51556             COND CMS TANTAL 47U 10V 20%    |
|      CE02          51556             COND CMS TANTAL 47U 10V 20%    |
|      CI01          W1356516          CI BLANKING CIRCUIT           |
|      ICSU01        4285              IC SUPPORT DIL8 TULIPE        |
|      ICSU02        4285              IC SUPPORT DIL8 TULIPE        |
|      J01           59995             ACCBL PICOT FOURCHE D1.1MM    |
|      J01'          59995             ACCBL PICOT FOURCHE D1.1MM    |
|      J02           59995             ACCBL PICOT FOURCHE D1.1MM    |
|      J02'          59995             ACCBL PICOT FOURCHE D1.1MM    |
|      J03           59995             ACCBL PICOT FOURCHE D1.1MM    |
|      J03'          59995             ACCBL PICOT FOURCHE D1.1MM    |
|      J04           59995             ACCBL PICOT FOURCHE D1.1MM    |
|      J04'          59995             ACCBL PICOT FOURCHE D1.1MM    |
|      J05           59995             ACCBL PICOT FOURCHE D1.1MM    |
|      J05'          59995             ACCBL PICOT FOURCHE D1.1MM    |
|      J06           59995             ACCBL PICOT FOURCHE D1.1MM    |
|      J06'          59995             ACCBL PICOT FOURCHE D1.1MM    |
|      J07           59995             ACCBL PICOT FOURCHE D1.1MM    |
|      J07'          59995             ACCBL PICOT FOURCHE D1.1MM    |
|      J08           59995             ACCBL PICOT FOURCHE D1.1MM    |
|      R01           20711             RES CMS 10 1% 0.25W 1206     |
|      R02           20711             RES CMS 10 1% 0.25W 1206     |
|      R03           20711             RES CMS 10 1% 0.25W 1206     |
|      R04           20711             RES CMS 10 1% 0.25W 1206     |
|      R05           73283             RES CMS 47.5 1% 0.25W 1206   |
|      R06           73283             RES CMS 47.5 1% 0.25W 1206   |
|      R07           20729             RES CMS 270 1% 0.25W 1206    |
|      R08           20739             RES CMS 1.5K 1% 0.25W 1206   |
|      R09           20745             RES CMS 4.7K 1% 0.25W 1206   |
|      RV01          34808             RES AJUST 200 0.5W 25T V     |
|      RV02          34808             RES AJUST 200 0.5W 25T V     |
|      RV03          34808             RES AJUST 200 0.5W 25T V     |
|      RV04          34808             RES AJUST 200 0.5W 25T V     |
|      RV05          11910             RES AJUST 1K 0.5W 25T V      |
|      RV06          11910             RES AJUST 1K 0.5W 25T V      |
|      U01           56507             IC 427/DRV TSC427CPA DIP8     |
|      U02           56507             IC 427/DRV TSC427CPA DIP8     |
|      U03           452               IC 317/VREG LM317T TO220      |
+-----+

```



NOTE:

J1 = 33011 : SMA CONNECTOR
 J2 = 33011 : SMA CONNECTOR
 CP1 = 56155 : BY-PASS 33NF
 CP2 = 56154 : BY-PASS 100PF
 CX = Capacitors to be optimized

ART: W1346089	EC: 00	DRAWN: DW DATE: 14/01/98	VISA:
LABX300 RF AMPLIFIER BOARD 30-325MHZ 300W LINEAR / 7dB		APPROV: CO DATE: 14/01/98	VISA:
DWG: W4S132168	A	SHEET: 1/1	



Figure 4.8. LABX300 RF Amplifier Board 30-325MHZ / 7dB Schematic

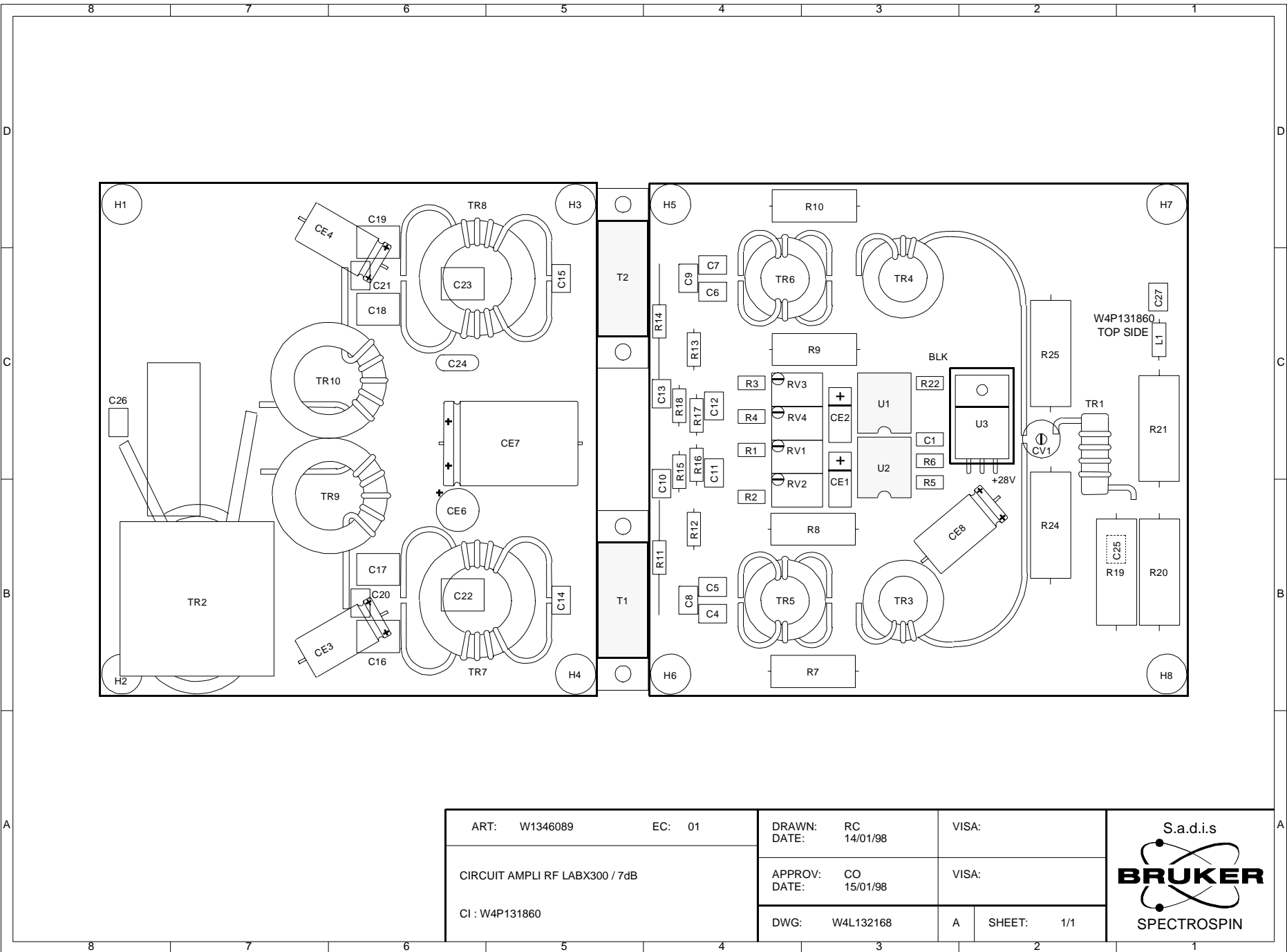
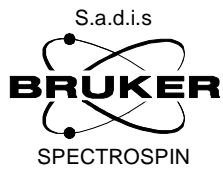


Figure 4.9. LABX300 RF Amplifier Board 30-325MHz / 7dB Location

ART: W1346089	EC: 01	DRAWN: RC	VISA:
CIRCUIT AMPLI RF LABX300 / 7dB		DATE: 14/01/98	
CI : W4P131860		APPROV: CO	VISA:
		DATE: 15/01/98	
		DWG: W4L132168	A SHEET: 1/1



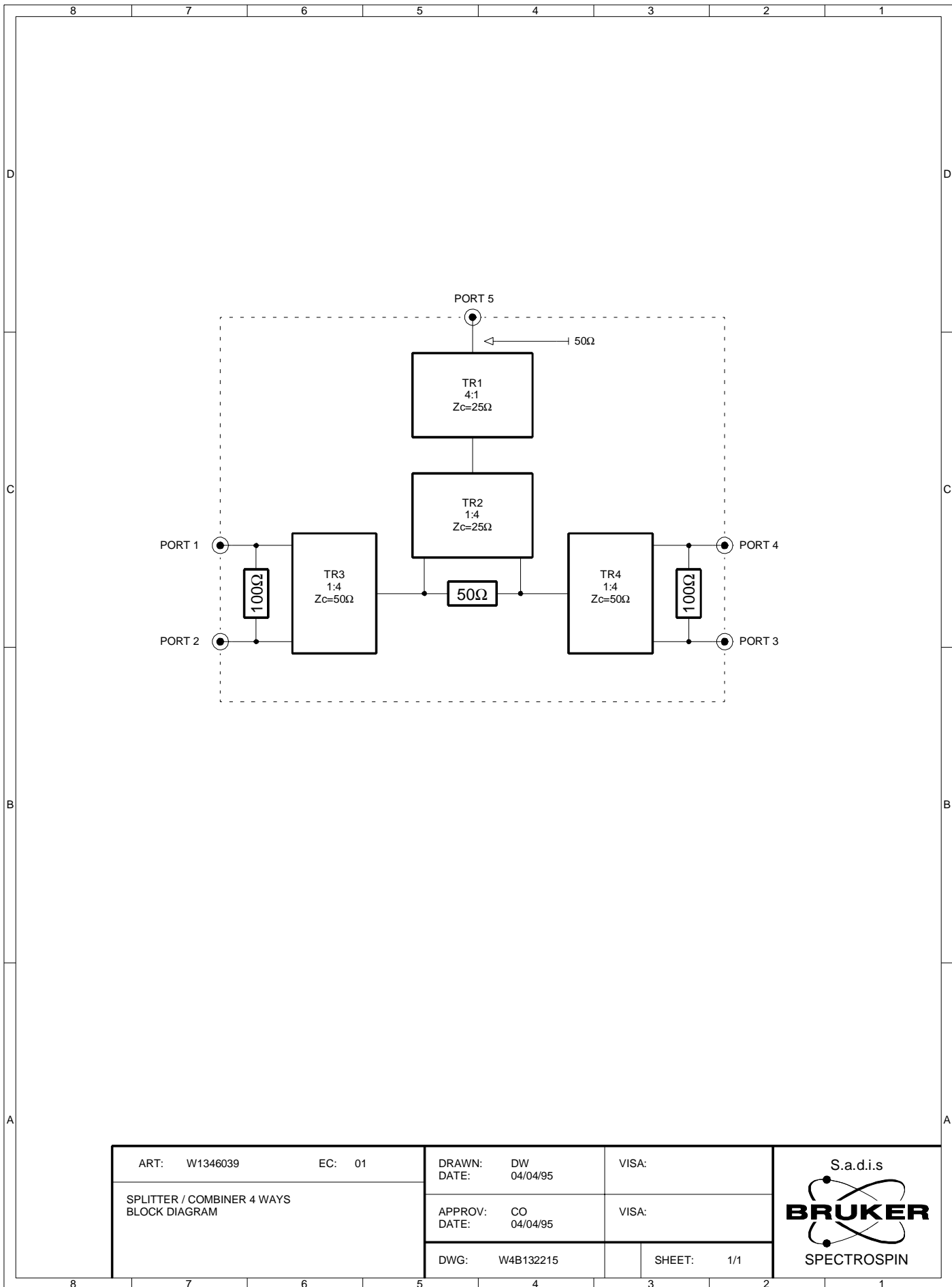
BLMX1000 RF Amplifier Module 30-325MHz

Value Table

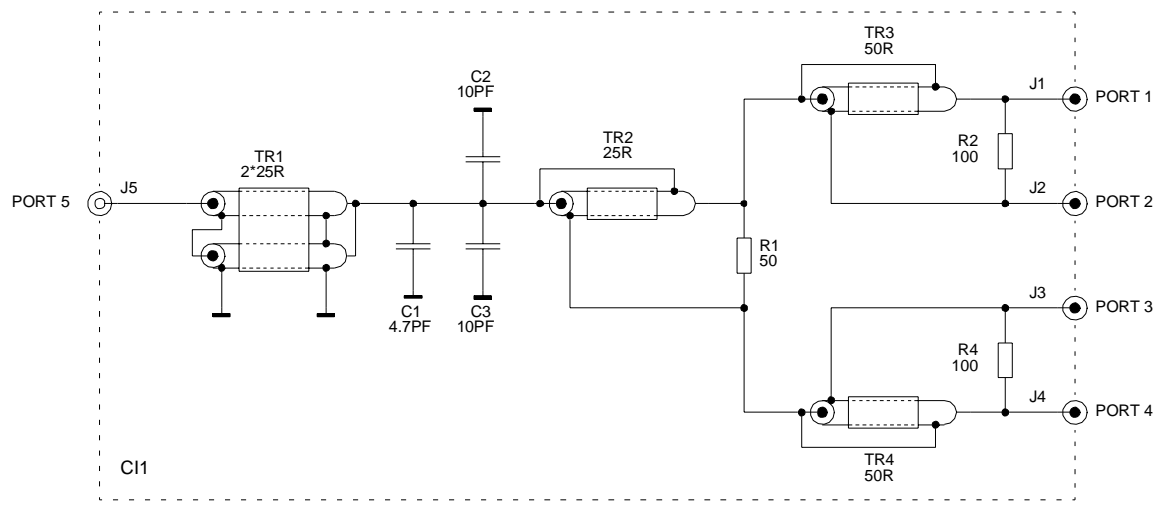
Value Tab Head			
Part:W1346089 Drawing:W4S132168A		Copy In Part:	Draw:
Desc:CIRCUIT AMPLI RF LABX300		ECL:1	Modified:25/04/97 By:MN
Value Tab			
Pos.	Component	Local Description	
C01	8493	COND CMS 1206 100N 50V 20% X7R	
C04	30424	COND CMS CDR14 1N 50V 20%	
C05	30424	COND CMS CDR14 1N 50V 20%	
C06	30424	COND CMS CDR14 1N 50V 20%	
C07	30424	COND CMS CDR14 1N 50V 20%	
C08	30409	COND CMS CDR14 56P 500V 20%	
C09	30409	COND CMS CDR14 56P 500V 20%	
C10	30424	COND CMS CDR14 1N 50V 20%	
C11	30424	COND CMS CDR14 1N 50V 20%	
C12	30424	COND CMS CDR14 1N 50V 20%	
C13	30424	COND CMS CDR14 1N 50V 20%	
C14	30410	COND CMS CDR14 68P 500V 20%	
C15	30410	COND CMS CDR14 68P 500V 20%	
C16	30197	COND CMS 2220 47N 100V SPT695E	
C17	30197	COND CMS 2220 47N 100V SPT695E	
C18	30197	COND CMS 2220 47N 100V SPT695E	
C19	30197	COND CMS 2220 47N 100V SPT695E	
C20	30400	COND CMS CDR14 10P 500V 20%	
C21	30400	COND CMS CDR14 10P 500V 20%	
C22	30197	COND CMS 2220 47N 100V SPT695E	
C23	30197	COND CMS 2220 47N 100V SPT695E	
C24	53242	COND CERM 1U 100V 10% X7R	
C25	30405	COND CMS CDR14 27P 500V 20%	
C26	30392	COND CMS CDR14 2.2P 500V 0.25P	
C27	30403	COND CMS CDR14 18P 500V 20%	
CE01	51556	COND CMS TANTAL 47U 10V 20%	
CE02	51556	COND CMS TANTAL 47U 10V 20%	
CE03	56066	COND CHIMI TANTAL 10U 40V AX	
CE04	56066	COND CHIMI TANTAL 10U 40V AX	
CE06	1985	COND CHIMI RAD 100U 50V 8X11.5	
CE07	374	COND CHIMI AX 2200U 40V 18X30	
CE08	56066	COND CHIMI TANTAL 10U 40V AX	
CI01	W1356616	CI AMPLI RF LABX300 7DB	
CV01	3204	COND VAR PLSTC 2-27P 250V D7.5	
L01	30142	SELF 0.10UH 1.38A	
R01	20711	RES CMS 10 1% 0.25W 1206	
R02	20711	RES CMS 10 1% 0.25W 1206	
R03	20711	RES CMS 10 1% 0.25W 1206	
R04	20711	RES CMS 10 1% 0.25W 1206	
R05	20729	RES CMS 270 1% 0.25W 1206	
R06	20739	RES CMS 1.5K 1% 0.25W 1206	
R07	6090	RES ACA 10 5% 2W	
R08	6090	RES ACA 10 5% 2W	
R09	6090	RES ACA 10 5% 2W	
R10	6090	RES ACA 10 5% 2W	
R11	31606	RES CCA 56 5% 1W	
R12	31606	RES CCA 56 5% 1W	
R13	31606	RES CCA 56 5% 1W	
R14	31606	RES CCA 56 5% 1W	
R15	1010	RES MET 1K 1% 0.6W 50PPM	
R16	1010	RES MET 1K 1% 0.6W 50PPM	
R17	1010	RES MET 1K 1% 0.6W 50PPM	
R18	1010	RES MET 1K 1% 0.6W 50PPM	
R19	6086	RES ACA 56 5% 2W	

Value Tab Head		
Part:W1346089	Drawing:W4S132168A	Copy In Part:
Desc:CIRCUIT AMPLI RF LABX300	ECL:1	Modified:25/04/97
		Draw: By:MN
Pos.	Component	Local Description
R20	6086	RES ACA 56 5% 2W
R21	6094	RES ACA 82 5% 2W
R22	20745	RES CMS 4.7K 1% 0.25W 1206
R24	2700	RES ACA 220 5% 2W
R25	2700	RES ACA 220 5% 2W
RV01	34808	RES AJUST 200 0.5W 25T V
RV02	34808	RES AJUST 200 0.5W 25T V
RV03	34808	RES AJUST 200 0.5W 25T V
RV04	34808	RES AJUST 200 0.5W 25T V
T01	56068	TRANS MRF175GV NFET 375-01 28V
T02	56068	TRANS MRF175GV NFET 375-01 28V
TR01	W1356644	TRSFO TORE 50R 1X3SP 115MM
TR02	W1356612	TRSFO BALUN 50R 1X2SP 210MM
TR03	W1356556	TRSFO TORE 25R 1X3SP 115MM
TR04	W1356556	TRSFO TORE 25R 1X3SP 115MM
TR05	W1356557	TRSFO TORE 12.5R 2X2SP 80MM
TR06	W1356557	TRSFO TORE 12.5R 2X2SP 80MM
TR07	W1356558	TRSFO TORE 12.5R 2X3SP 135MM
TR08	W1356558	TRSFO TORE 12.5R 2X3SP 135MM
TR09	W1356559	TRSFO TORE 25R 1X5SP 190MM
TR10	W1356559	TRSFO TORE 25R 1X5SP 190MM
U01	56507	IC 427/DRV TSC427CPA DIP8
U02	56507	IC 427/DRV TSC427CPA DIP8
U03	452	IC 317/VREG LM317T TO220

Figure 4.10. Splitter / Combiner 4 Ways Block Diagram



ART: W1346039	EC: 01	DRAWN: DW	VISA:	
SPLITTER / COMBINER 4 WAYS BLOCK DIAGRAM		DATE: 04/04/95		
		APPROV: CO	VISA:	
		DATE: 04/04/95		
		DWG: W4B132215	SHEET: 1/1	



ART: W1346039	EC: 01	DRAWN: DW	VISA:
SPLITTER / COMBINER 4 WAYS		DATE: 04/04/95	DATE: 04/04/95
		APPROV: CO	VISA:
		DATE: 04/04/95	DATE: 04/04/95
DWG: W4S132215		SHEET: 1/1	

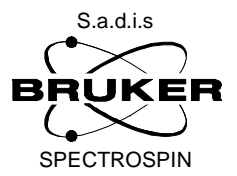


Figure 4.11. Splitter / Combiner 4 Ways Schematic

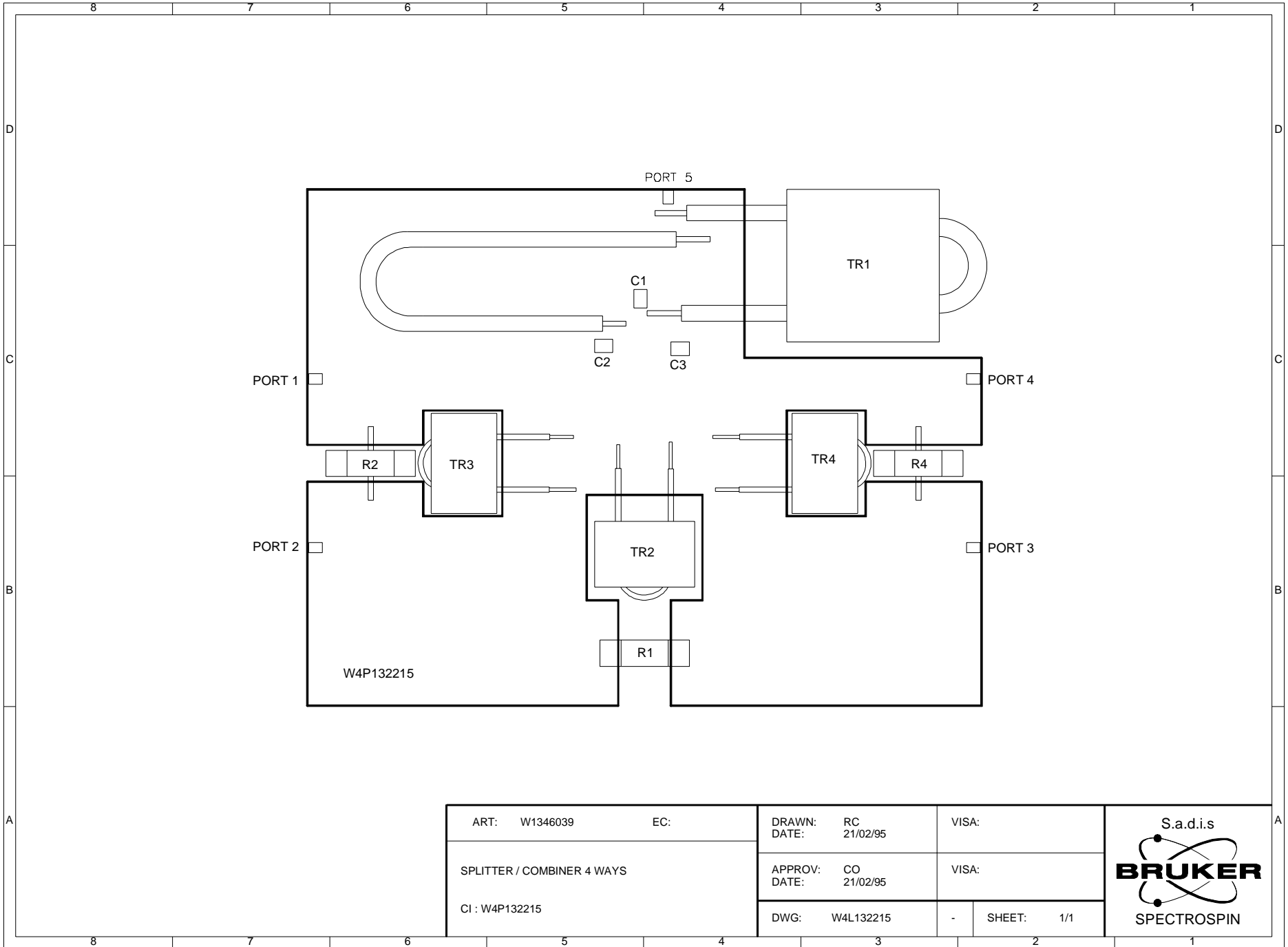
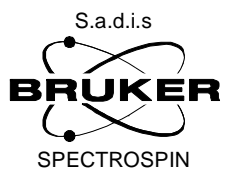


Figure 4.12: Splitter / Combiner 4 Ways Location

ART: W1346039	EC:	DRAWN: RC	VISA:
SPLITTER / COMBINER 4 WAYS		DATE: 21/02/95	
CI : W4P132215		APPROV: CO	VISA:
		DATE: 21/02/95	
		DWG: W4L132215	- SHEET: 1/1



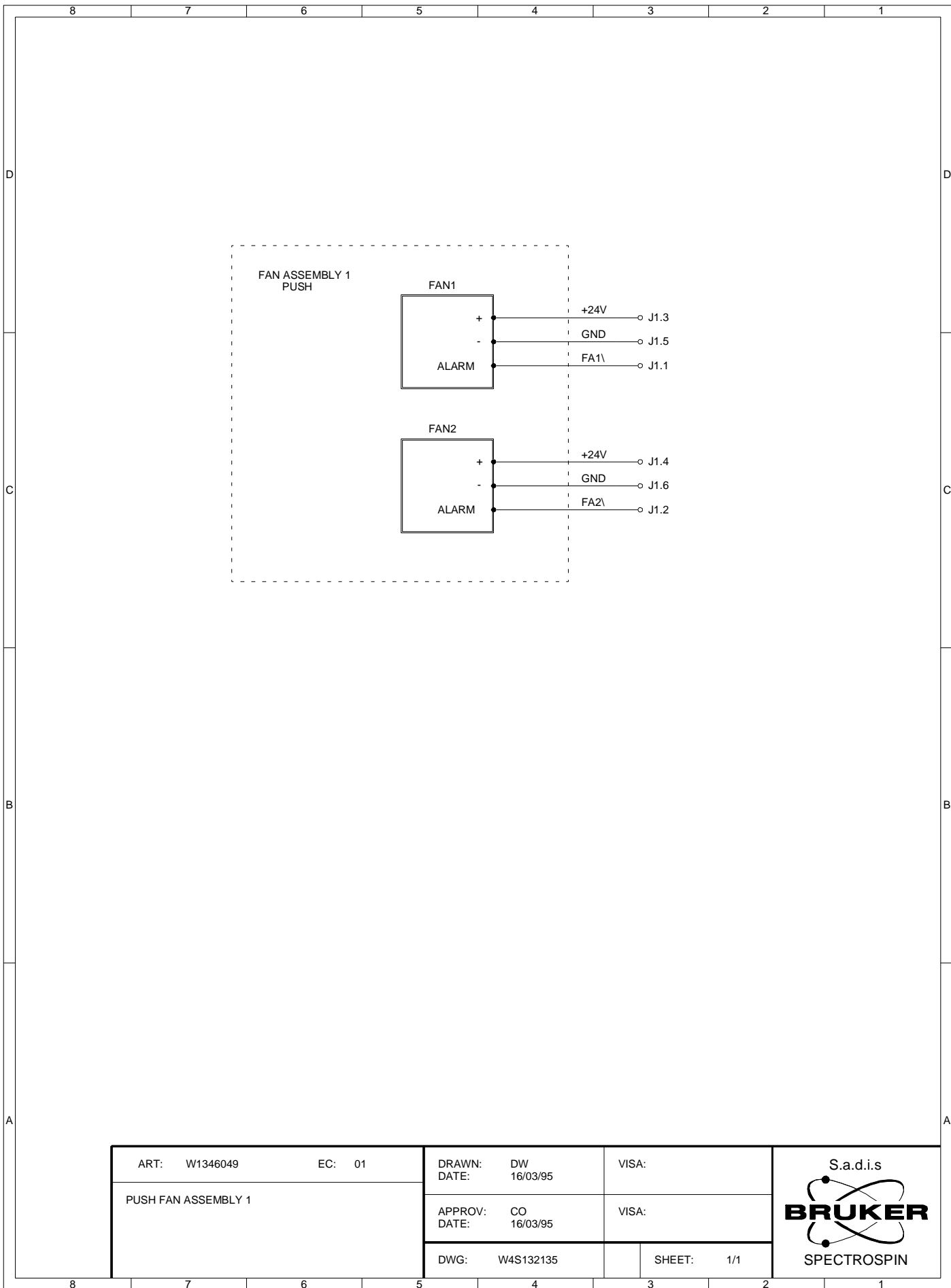
Value Table

```

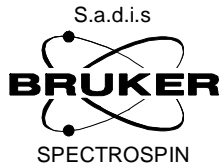
+-- Value Tab Head -----+
| Part:W1346039 Drawing:W4S132215          Copy In Part:          Draw:          |
| Desc:SPLITTEUR COMBINEUR 4 VOIES      ECL:1          Modified:09/05/96      By:DW          |
+-- Value Tab -----+
|      Pos.          Component          Local Description          |
|      C01          30396          COND CMS CDR14 4.7P 500V 0.25P |
|      C02          30400          COND CMS CDR14 10P 500V 20%      |
|      C03          30400          COND CMS CDR14 10P 500V 20%      |
|      CI01         W1356611         CI SPLITTEUR COMBINEUR 4 VOIES |
|      J01          33011          CN COAX SMA F D EMB PLATINE      |
|      J02          33011          CN COAX SMA F D EMB PLATINE      |
|      J03          33011          CN COAX SMA F D EMB PLATINE      |
|      J04          33011          CN COAX SMA F D EMB PLATINE      |
|      J05          33011          CN COAX SMA F D EMB PLATINE      |
|      R01          56307          RES HF 50 5% 75W                |
|      R02          56306          RES HF 100 5% 40W               |
|      R04          56306          RES HF 100 5% 40W               |
|      TR01         W1356613         TRSFO BALUN 25R 2X1SP 130MM      |
|      TR02         W1356614         TRSFO BALUN 25R 1X1SP 60MM      |
|      TR03         W1356615         TRSFO BALUN 50R 1X1SP 65MM      |
|      TR04         W1356615         TRSFO BALUN 50R 1X1SP 65MM      |
+-----+

```

Figure 4.13. Push Fan Assembly 1 Schematic



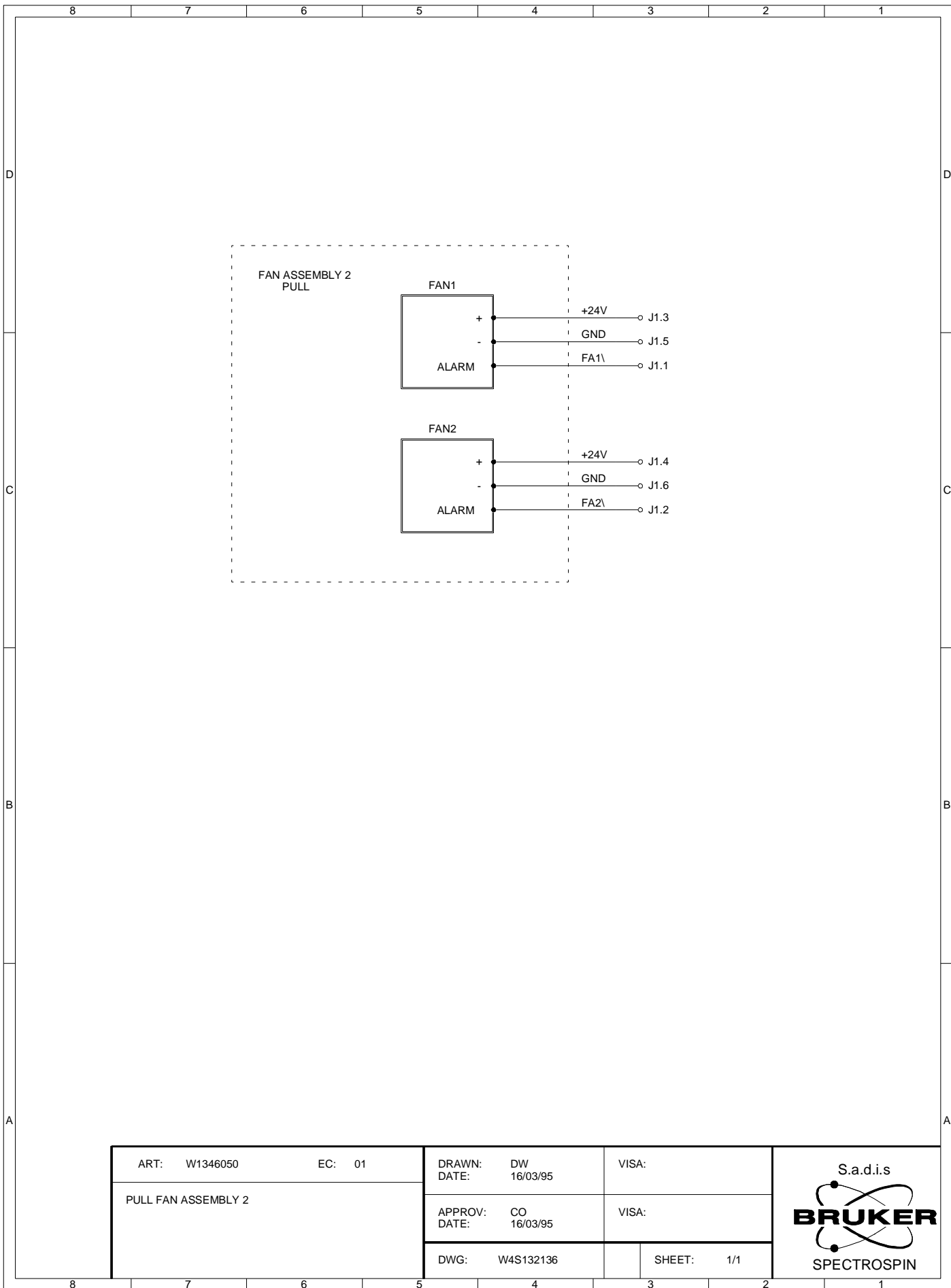
ART: W1346049	EC: 01	DRAWN: DW	DATE: 16/03/95	VISA:
PUSH FAN ASSEMBLY 1		APPROV: CO	DATE: 16/03/95	VISA:
		DWG: W4S132135	SHEET: 1/1	



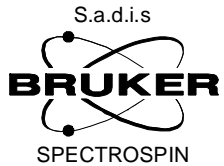
Value Table

```
+-- Value Tab Head -----+
| Part:W1346049 Drawing:W4S132135          Copy In Part:      Draw:      |
| Desc:BLOC VENTILATEUR INSSUFL. 1      ECL:1          Modified:09/05/96  By:DW      |
+-- Value Tab -----+
|      Pos.          Component          Local Description      |
|      FAN01         56417             VENT 24V=80X25MM A FIL  |
|      FAN02         56417             VENT 24V=80X25MM A FIL  |
|      J01           35486             CN F 6 SRT BOI 6471     |
+-----+
```

Figure 4.14. Pull Fan Assembly 2 Schematic



ART: W1346050	EC: 01	DRAWN: DW	DATE: 16/03/95	VISA:
PULL FAN ASSEMBLY 2		APPROV: CO	DATE: 16/03/95	VISA:
		DWG: W4S132136		SHEET: 1/1



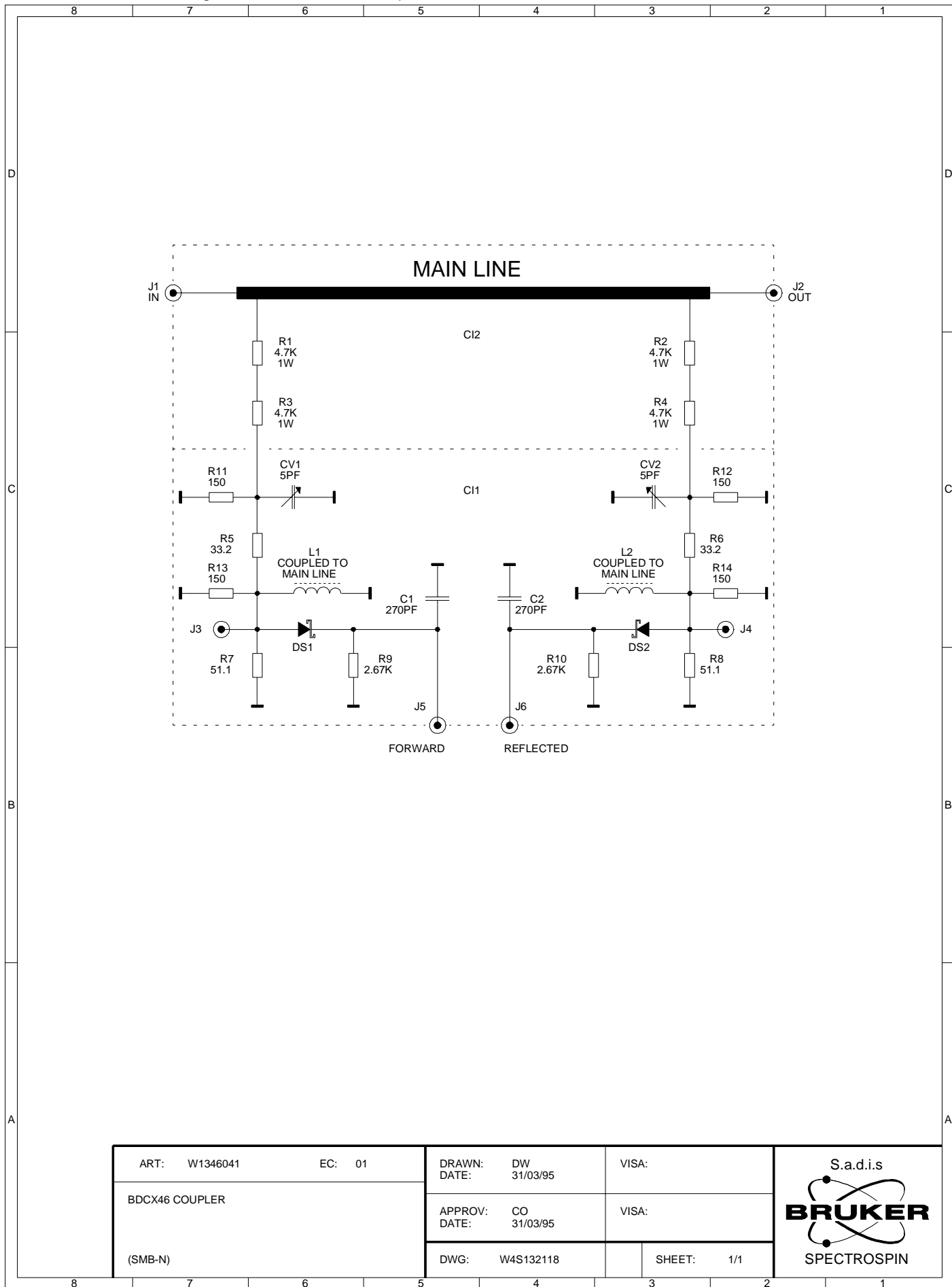
Value Table

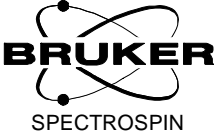
```
+-- Value Tab Head -----+
| Part:W1346050 Drawing:W4S132136          Copy In Part:      Draw:      |
| Desc:BLOC VENTILATEUR EXTRACT. 2      ECL:1          Modified:09/05/96  By:DW      |
+-- Value Tab -----+
|      Pos.          Component          Local Description      |
|      FAN01        56417              VENT 24V=80X25MM A FIL  |
|      FAN02        56417              VENT 24V=80X25MM A FIL  |
|      J01          35486              CN F 6 SRT BOI 6471    |
+-----+
```


BDCX46 Coupler

5

Figure 5.1. BDCX46 Coupler Schematic



ART: W1346041	EC: 01	DRAWN: DW	VISA:	S.a.d.i.s  SPECTROSPIN
BDCX46 COUPLER		DATE: 31/03/95	DATE: 31/03/95	
(SMB-N)	DWG: W4S132118	SHEET: 1/1		

Value Table

```

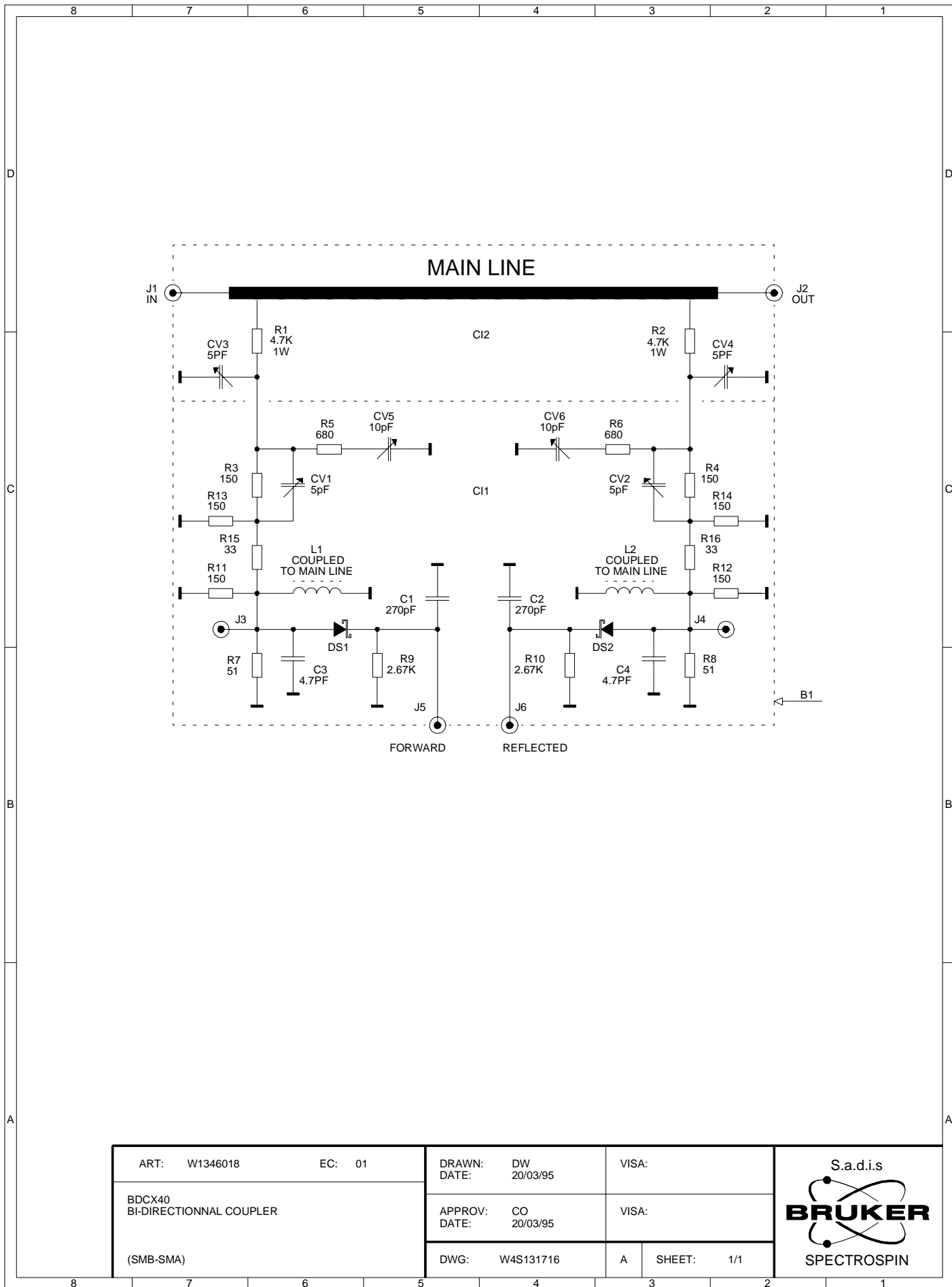
+-- Value Tab Head -----+
| Part:W1346041 Drawing:W4S132118          Copy In Part:          Draw:          |
| Desc:COUPLEUR BDCX46                    ECL:1          Modified:15/01/96    By:DW          |
+-- Value Tab -----+
|      Pos.          Component          Local Description          |
|      C01          30417          COND CMS CDR14 270P 200V 20% |
|      C02          30417          COND CMS CDR14 270P 200V 20% |
|      CI01         W1356353         CI BI-DIRECT. COUPLEUR B-DCX |
|      CI02         W1356165         CI BI-DIRECT. COUPLEUR          |
|      CV01         31299          COND VAR CER 2.5-5P 63V NPO    |
|      CV02         31299          COND VAR CER 2.5-5P 63V NPO    |
|      DS01         56291          DIODE S CMS MSS20-046-E28      |
|      DS02         56291          DIODE S CMS MSS20-046-E28      |
|      ETI01        56436          MP A ETIQUETTE COUP BDCX 70X41 |
|      J01          W1305760         MOD. CN COAX N F COUPLEUR      |
|      J02          W1305760         MOD. CN COAX N F COUPLEUR      |
|      J03          1235           CN COAX SMB M D PRT            |
|      J04          1235           CN COAX SMB M D PRT            |
|      J05          1237           CN COAX SMB M D EMB ECROU      |
|      J06          1237           CN COAX SMB M D EMB ECROU      |
|      L01          W1356602         SELF 12SP/FERRITE D3 CUE D0.4  |
|      L02          W1356602         SELF 12SP/FERRITE D3 CUE D0.4  |
|      MEC01        W1305473         BOITIER COUPLEUR B-LA          |
|      MEC02        W1305474         COUPLEUR BDC COUVERCLE 1       |
|      MEC03        W1305474         COUPLEUR BDC COUVERCLE 1       |
|      R01          56308          RES ACA 4.7K 5% 1W            |
|      R02          56308          RES ACA 4.7K 5% 1W            |
|      R03          56308          RES ACA 4.7K 5% 1W            |
|      R04          56308          RES ACA 4.7K 5% 1W            |
|      R05          20717          RES CMS 33.2 1% 0.25W 1206     |
|      R06          20717          RES CMS 33.2 1% 0.25W 1206     |
|      R07          20765          RES CMS 51.1 1% 0.25W 1206     |
|      R08          20765          RES CMS 51.1 1% 0.25W 1206     |
|      R09          35183          RES MET 2.67K 1% 0.6W 50PPM    |
|      R10          35183          RES MET 2.67K 1% 0.6W 50PPM    |
|      R11          20726          RES CMS 150 1% 0.25W 1206      |
|      R12          20726          RES CMS 150 1% 0.25W 1206      |
|      R13          20726          RES CMS 150 1% 0.25W 1206      |
|      R14          20726          RES CMS 150 1% 0.25W 1206      |
+-----+

```


BDCX40 Coupler

6

Figure 6.1. BDCX40 Coupler Schematic



ART: W1346018	EC: 01	DRAWN: DW	VISA:	
BDCX40 BI-DIRECTIONAL COUPLER		DATE: 20/03/95	20/03/95	
(SMB-SMA)		APPROV: CO	VISA:	
		DATE: 20/03/95		
		DWG: W4S131716	A	SHEET: 1/1

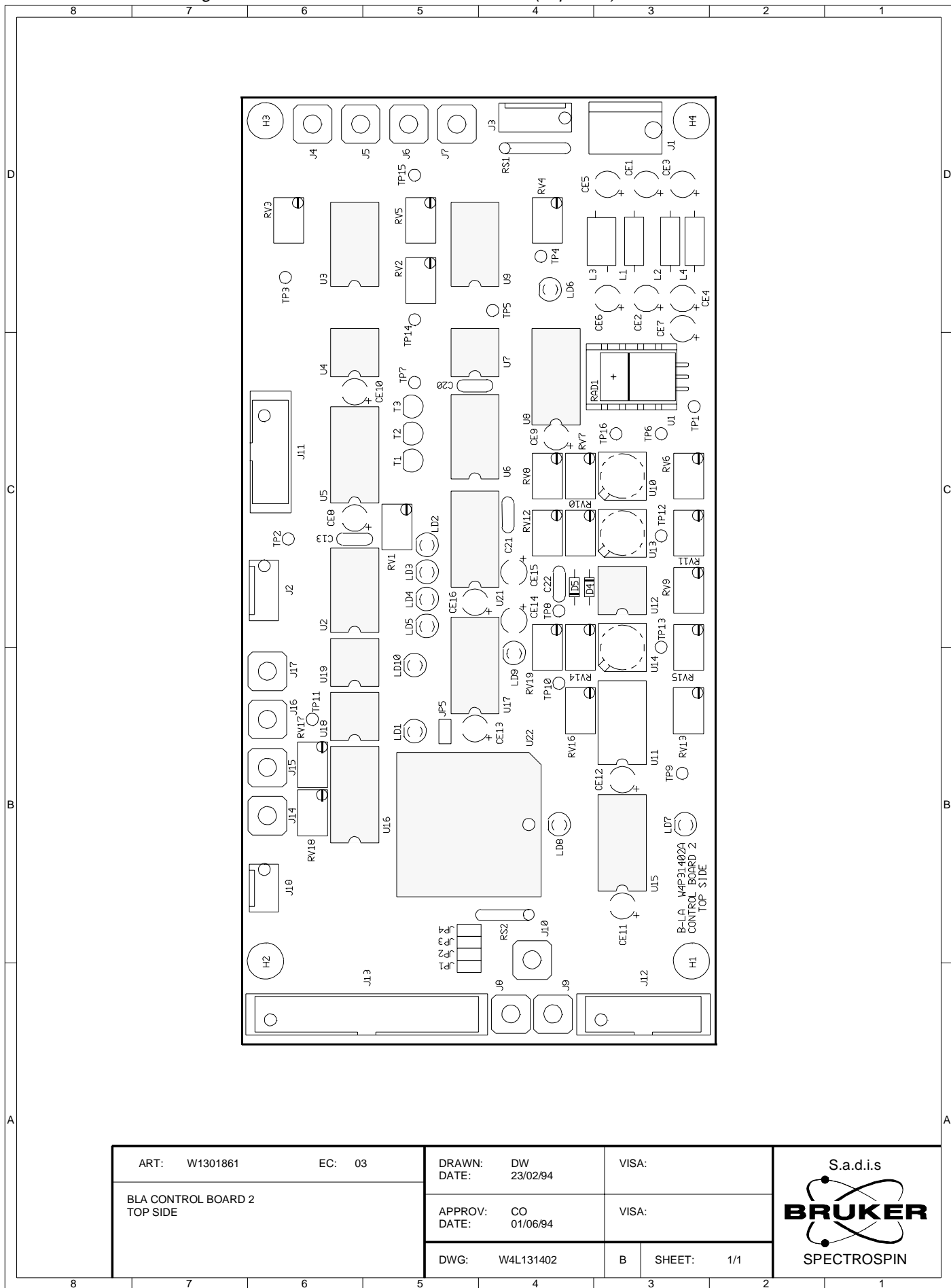
Value Table

+-- Value Tab Head -----+			
Part:W1346018	Drawing:W4S131716A	Copy In Part:	Draw:
Desc:COUPLEUR BDCX40	ECL:2	Modified:18/01/96	By:DW
+-- Value Tab -----+			
Pos.	Component	Local Description	
C01	30417	COND CMS CDR14 270P 200V 20%	
C02	30417	COND CMS CDR14 270P 200V 20%	
C03	30396	COND CMS CDR14 4.7P 500V 0.25P	
C04	30396	COND CMS CDR14 4.7P 500V 0.25P	
CI01	W1356353	CI BI-DIRECT. COUPLEUR B-DCX	
CI02	W1356165	CI BI-DIRECT. COUPLEUR	
CV01	31299	COND VAR CER 2.5-5P 63V NPO	
CV02	31299	COND VAR CER 2.5-5P 63V NPO	
CV03	31299	COND VAR CER 2.5-5P 63V NPO	
CV04	31299	COND VAR CER 2.5-5P 63V NPO	
CV05	31300	COND VAR CER 3.5-10P 63V NPO	
CV06	31300	COND VAR CER 3.5-10P 63V NPO	
DS01	56291	DIODE S CMS MSS20-046-E28	
DS02	56291	DIODE S CMS MSS20-046-E28	
ETI01	56436	MP A ETIQUETTE COUP BDCX 70X41	
J01	33011	CN COAX SMA F D EMB PLATINE	
J02	33011	CN COAX SMA F D EMB PLATINE	
J03	1235	CN COAX SMB M D PRT	
J04	1235	CN COAX SMB M D PRT	
J05	1237	CN COAX SMB M D EMB ECROU	
J06	1237	CN COAX SMB M D EMB ECROU	
L01	W1356602	SELF 12SP/FERRITE D3 CUE D0.4	
L02	W1356602	SELF 12SP/FERRITE D3 CUE D0.4	
MEC01	W1305720	B-DCH BOITIER COUPLEUR SMA	
MEC02	W1305474	COUPLEUR BDC COUVERCLE 1	
MEC03	W1305474	COUPLEUR BDC COUVERCLE 1	
R01	56308	RES ACA 4.7K 5% 1W	
R02	56308	RES ACA 4.7K 5% 1W	
R03	20726	RES CMS 150 1% 0.25W 1206	
R04	20726	RES CMS 150 1% 0.25W 1206	
R05	20734	RES CMS 681 1% 0.25W 1206	
R06	20734	RES CMS 681 1% 0.25W 1206	
R07	20765	RES CMS 51.1 1% 0.25W 1206	
R08	20765	RES CMS 51.1 1% 0.25W 1206	
R09	35183	RES MET 2.67K 1% 0.6W 50PPM	
R10	35183	RES MET 2.67K 1% 0.6W 50PPM	
R11	20726	RES CMS 150 1% 0.25W 1206	
R12	20726	RES CMS 150 1% 0.25W 1206	
R13	20726	RES CMS 150 1% 0.25W 1206	
R14	20726	RES CMS 150 1% 0.25W 1206	
R15	20717	RES CMS 33.2 1% 0.25W 1206	
R16	20717	RES CMS 33.2 1% 0.25W 1206	

BLA Control Board 2

7

Figure 7.1. BLA Control Board 2 Location (Top Side)



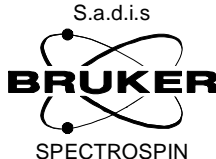
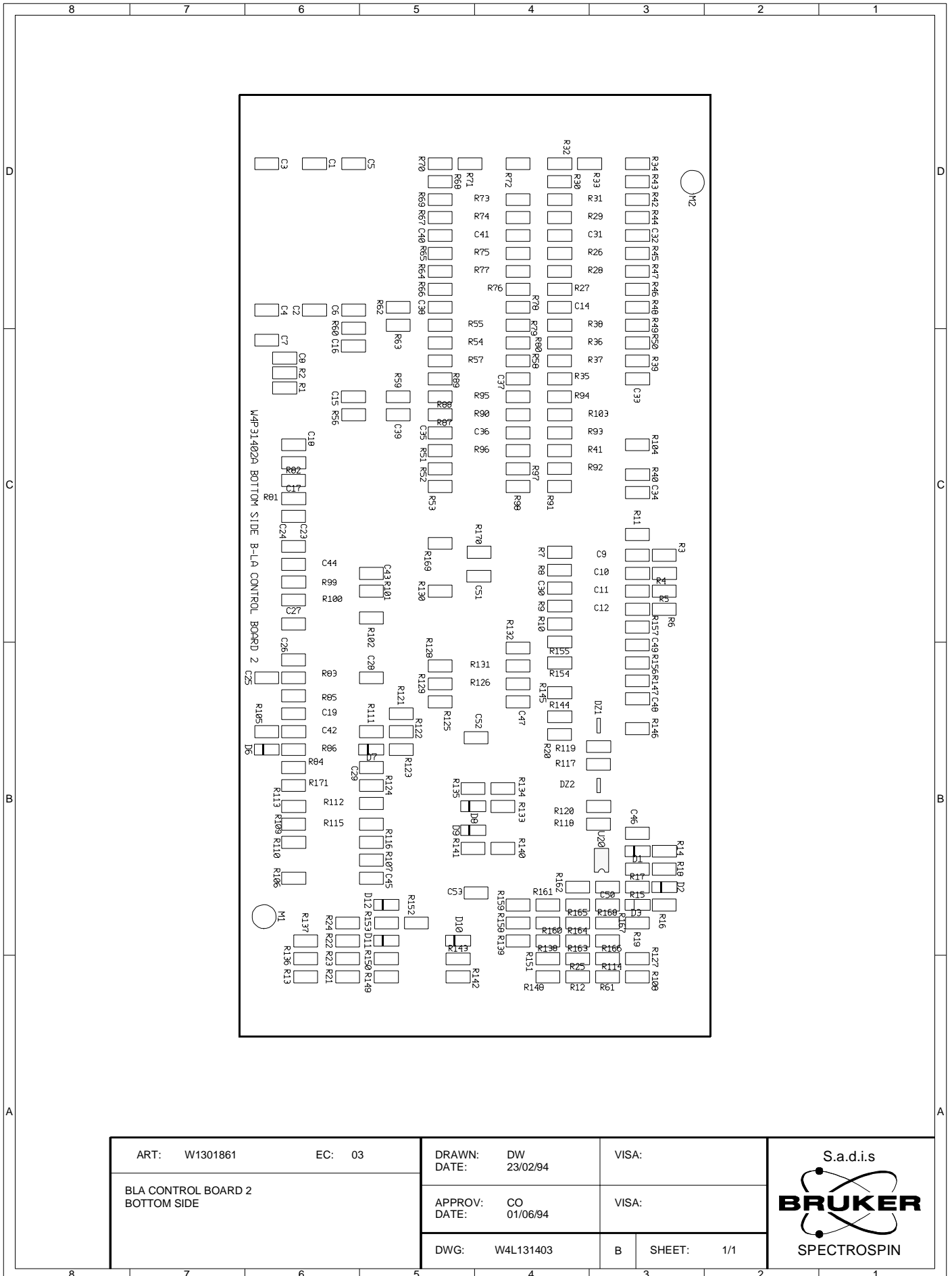
ART: W1301861	EC: 03	DRAWN: DW	VISA:	
BLA CONTROL BOARD 2 TOP SIDE		DATE: 23/02/94	DATE: 01/06/94	
		DWG: W4L131402	SHEET: 1/1	

Figure 7.2. BLA Control Board 2 Location (Bottom Side)



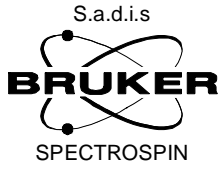
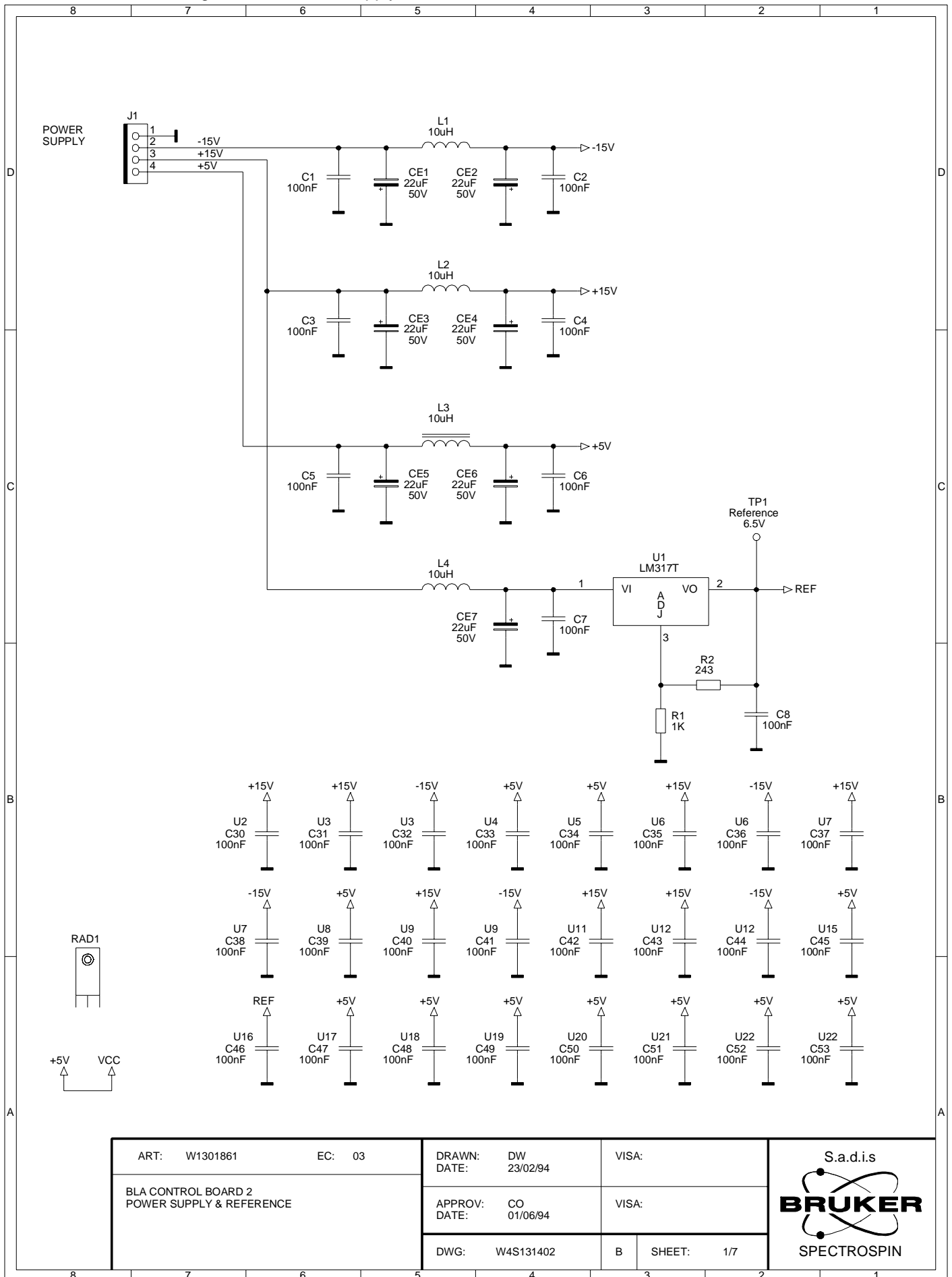
ART: W1301861	EC: 03	DRAWN: DW	VISA:	
BLA CONTROL BOARD 2 BOTTOM SIDE		DATE: 23/02/94	DATE: 01/06/94	
		DWG: W4L131403	SHEET: 1/1	

Figure 7.3. Power Supply & Reference Schematic



ART: W1301861	EC: 03	DRAWN: DW	23/02/94	VISA:	
BLA CONTROL BOARD 2 POWER SUPPLY & REFERENCE		APPROV: CO	01/06/94	VISA:	
DWG: W4S131402	B	SHEET: 1/7			

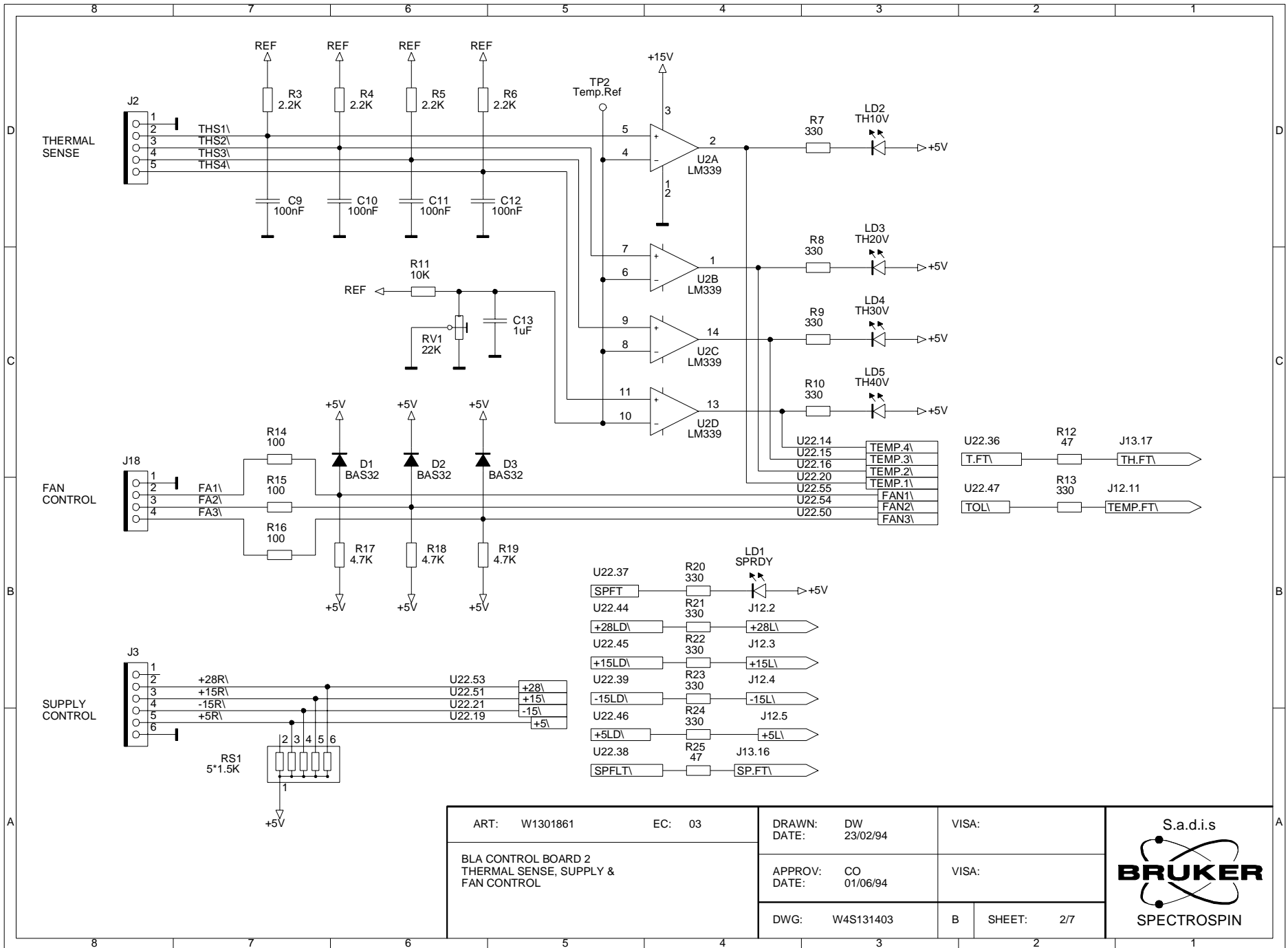
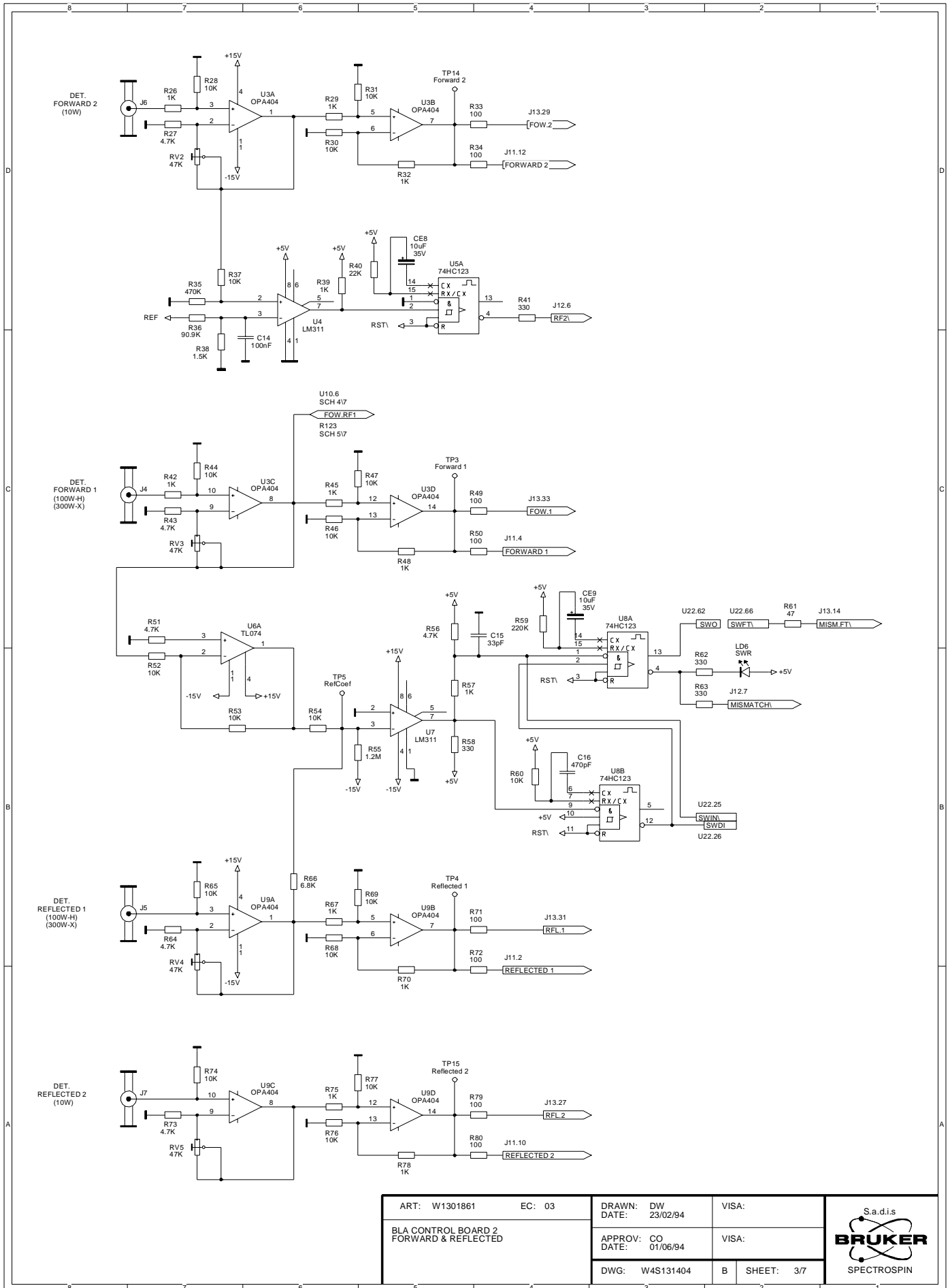


Figure 7.4. Thermal Sense, Supply & Fan Control Schematic

ART: W1301861	EC: 03	DRAWN: DW DATE: 23/02/94	VISA:	
BLA CONTROL BOARD 2 THERMAL SENSE, SUPPLY & FAN CONTROL		APPROV: CO DATE: 01/06/94	VISA:	
		DWG: W4S131403	B SHEET: 2/7	

Figure 7.5. Forward & Reflected Schematic



ART: W1301861	EC: 03	DRAWN: DW DATE: 23/02/94	VISA:
BLA CONTROL BOARD 2 FORWARD & REFLECTED		APPROV: CO DATE: 01/06/94	VISA:
		DWG: W4S131404	B SHEET: 3/7



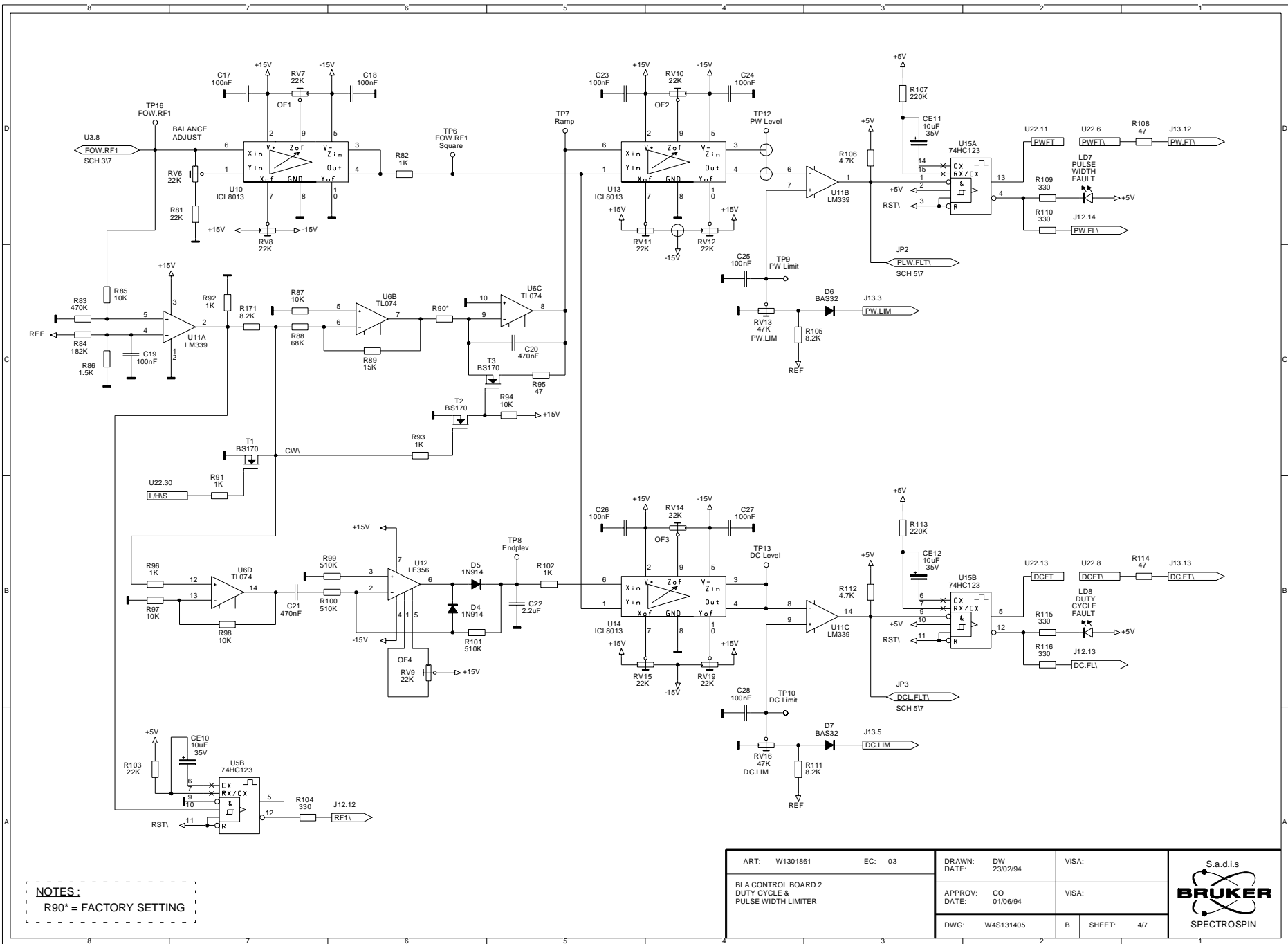


Figure 7.6. Duty Cycle & Pulse width Limiter Schematic

NOTES:
R90* = FACTORY SETTING

ART: W1301861	EC: 03	DRAWN: DW 23/02/94	VISA:
BLA CONTROL BOARD 2 DUTY CYCLE & PULSE WIDTH LIMITER		APPROV: CO 01/06/94	VISA:
		DWG: W4S131405	B SHEET: 4/7



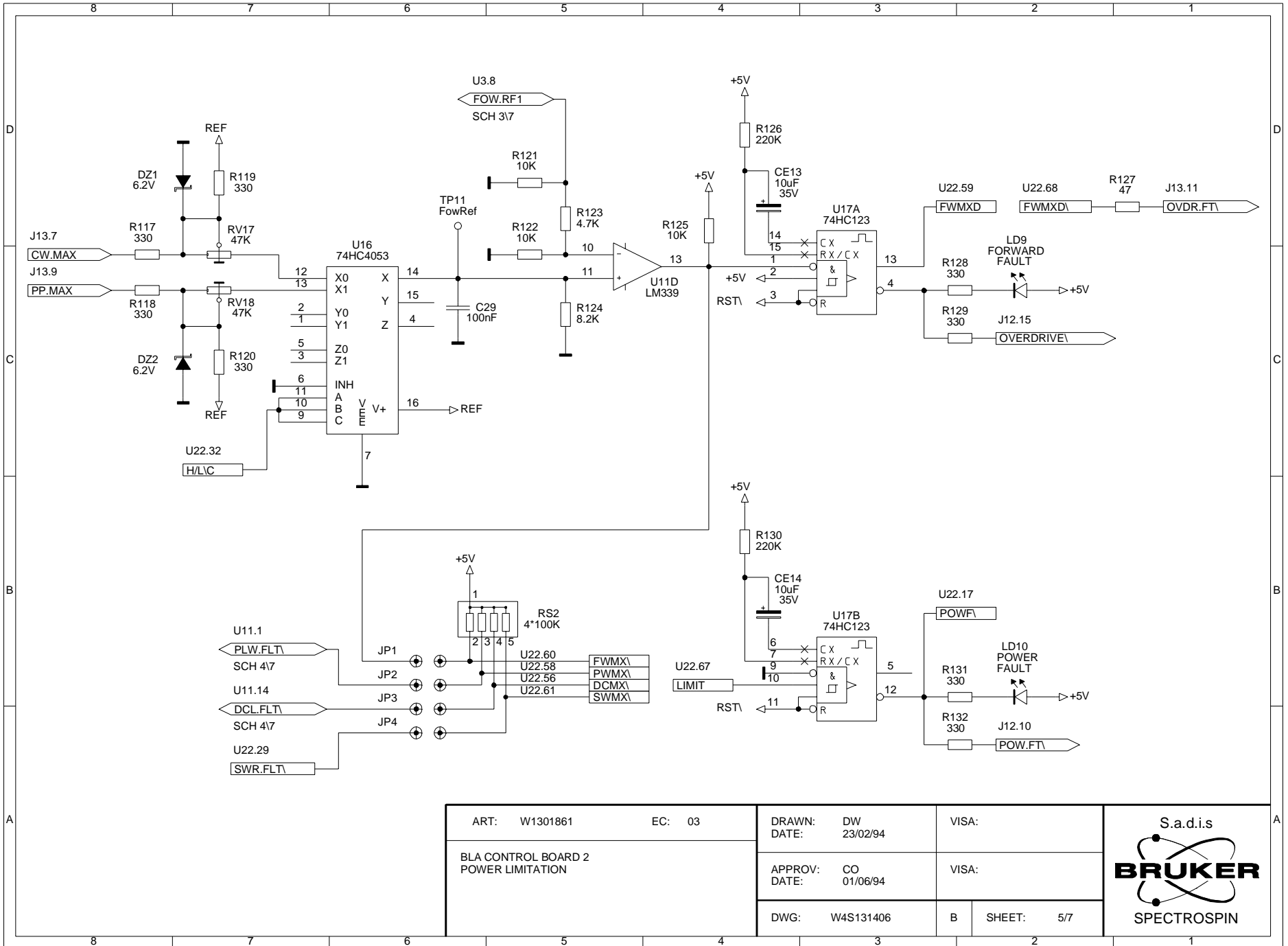
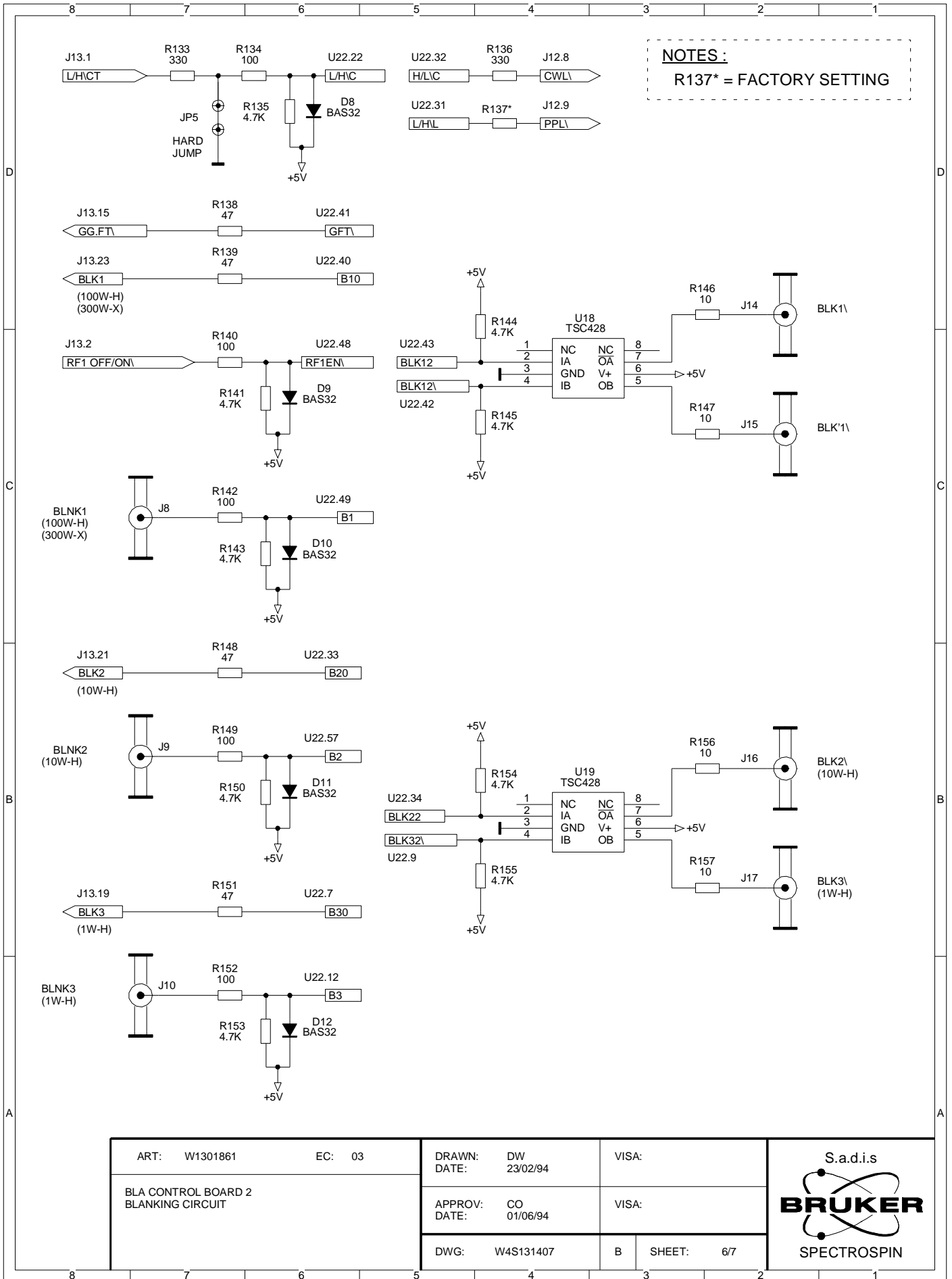


Figure 7.7. Power Limitation Schematic

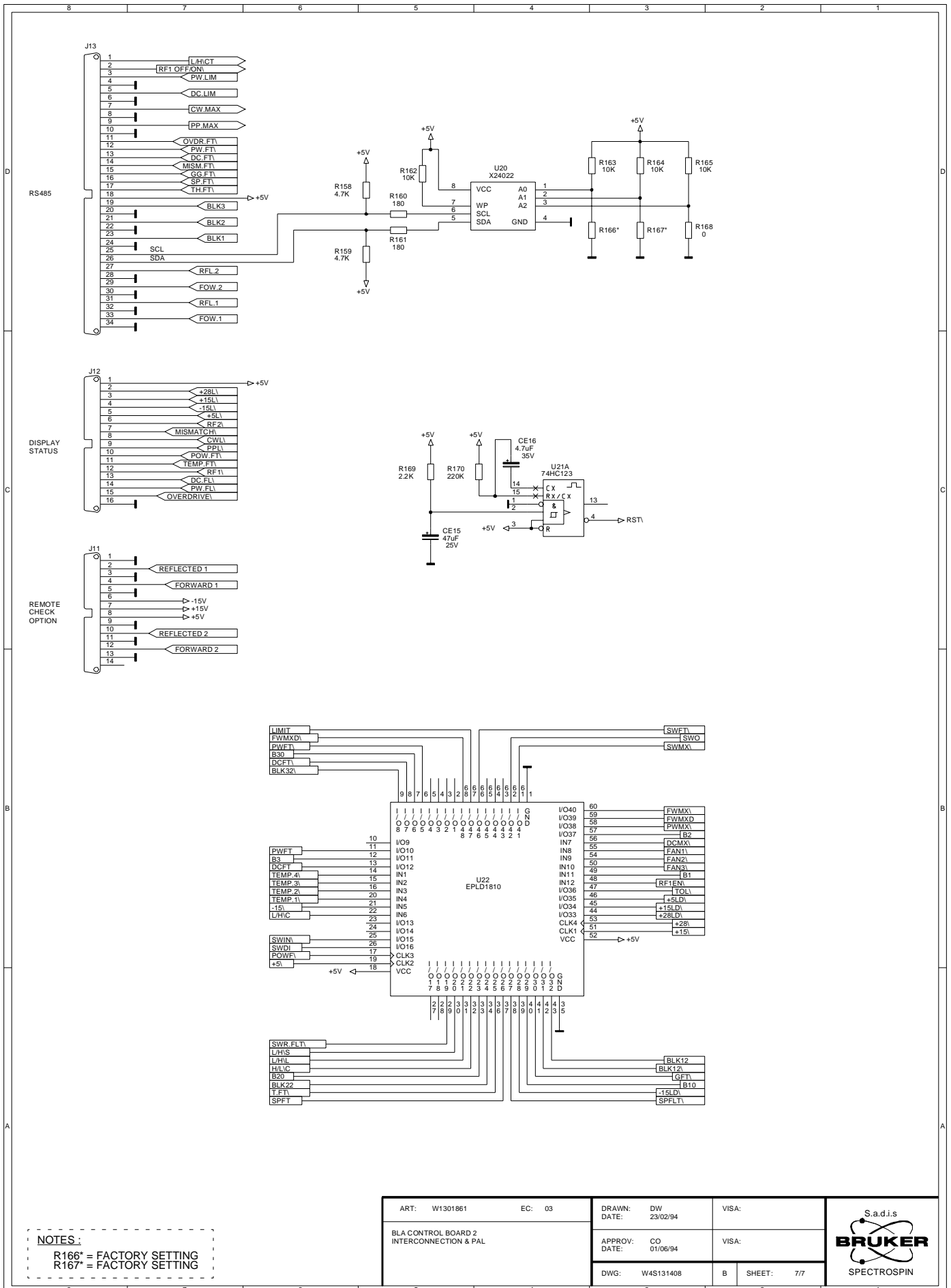
ART: W1301861	EC: 03	DRAWN: DW	VISA:	
BLA CONTROL BOARD 2 POWER LIMITATION		DATE: 23/02/94	VISA:	
		APPROV: CO	VISA:	
		DATE: 01/06/94	B	SHEET: 5/7
		DWG: W4S131406		

Figure 7.8. Blanking Circuit Schematic



ART: W1301861	EC: 03	DRAWN: DW	VISA:	S.a.d.i.s SPECTROSPIN
BLA CONTROL BOARD 2 BLANKING CIRCUIT		DATE: 23/02/94	DATE: 01/06/94	
DWG: W4S131407	B	SHEET: 6/7	VISA:	

Figure 7.9. Interconnection & Pal Schematic

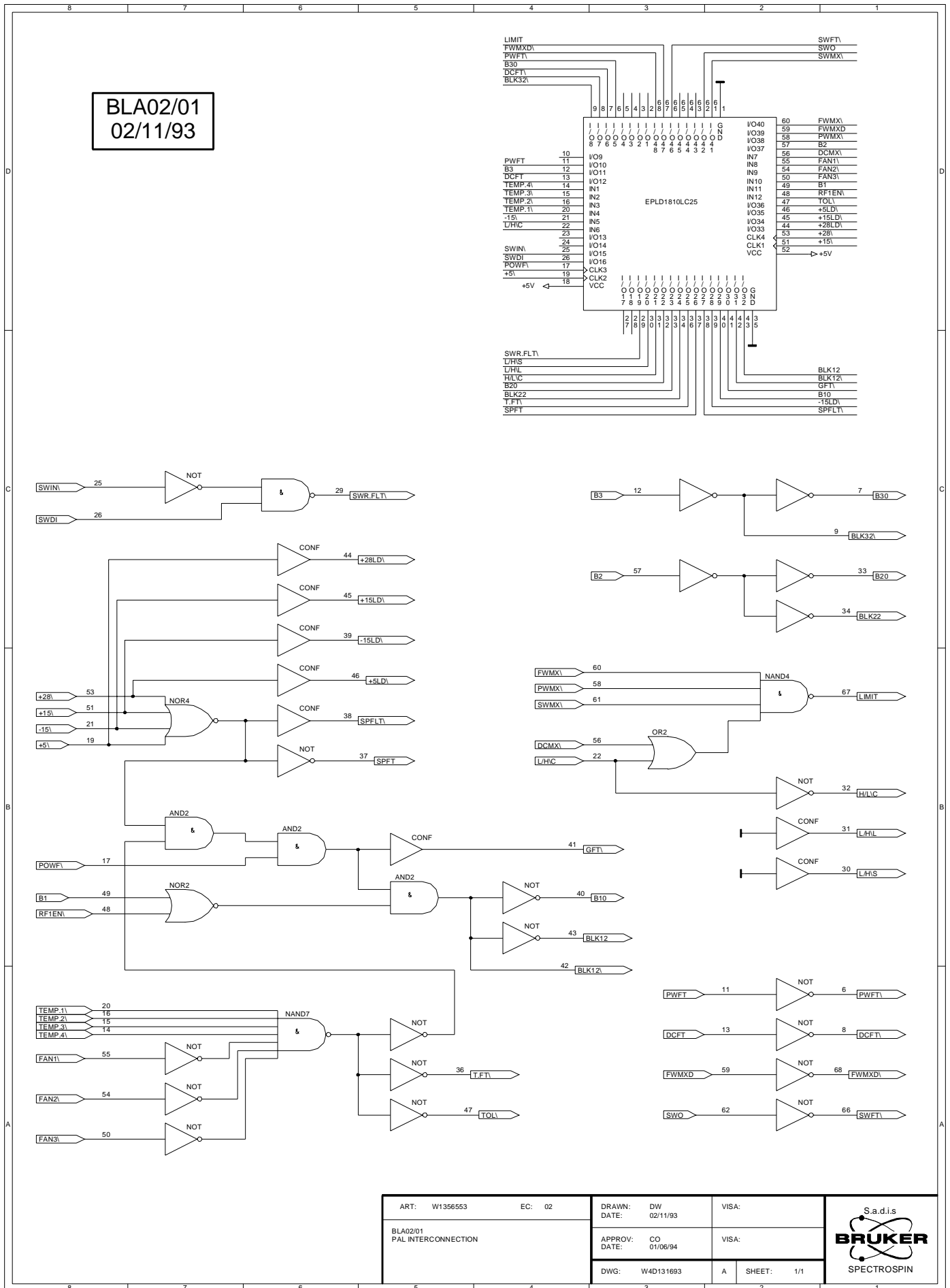


NOTES:
 R166* = FACTORY SETTING
 R167* = FACTORY SETTING

ART: W1301861	EC: 03	DRAWN: DW DATE: 23/02/94	VISA:
BLA CONTROL BOARD 2 INTERCONNECTION & PAL		APPROV: CO DATE: 01/06/94	VISA:
		DWG: W4S131408	B SHEET: 7/7



Figure 7.10. Pal BLA02/01 Hardware Schematic



BLA Control Board 2

Value Table

Value Tab Head		-----	
Part:W1301861	Drawing:W4S131402B	Copy In Part:	Draw:
Desc:BLA CONTROL BOARD 2	ECL:3	Modified:21/01/97	By:MN
Value Tab		-----	
Pos.	Component	Local Description	
C01	8493	COND CMS 1206 100N 50V 20% X7R	
C02	8493	COND CMS 1206 100N 50V 20% X7R	
C03	8493	COND CMS 1206 100N 50V 20% X7R	
C04	8493	COND CMS 1206 100N 50V 20% X7R	
C05	8493	COND CMS 1206 100N 50V 20% X7R	
C06	8493	COND CMS 1206 100N 50V 20% X7R	
C07	8493	COND CMS 1206 100N 50V 20% X7R	
C08	8493	COND CMS 1206 100N 50V 20% X7R	
C09	8493	COND CMS 1206 100N 50V 20% X7R	
C10	8493	COND CMS 1206 100N 50V 20% X7R	
C11	8493	COND CMS 1206 100N 50V 20% X7R	
C12	8493	COND CMS 1206 100N 50V 20% X7R	
C13	53242	COND CERM 1U 100V 10% X7R	
C14	8493	COND CMS 1206 100N 50V 20% X7R	
C15	20984	COND CMS 1206 33P 50V 5% NPO	
C16	20998	COND CMS 1206 470P 50V 5% NPO	
C17	8493	COND CMS 1206 100N 50V 20% X7R	
C18	8493	COND CMS 1206 100N 50V 20% X7R	
C19	8493	COND CMS 1206 100N 50V 20% X7R	
C20	34772	COND CERM 470N 100V 10% X7R	
C21	34772	COND CERM 470N 100V 10% X7R	
C22	52424	COND CERM 2.2U 63V 20% Z5U	
C23	8493	COND CMS 1206 100N 50V 20% X7R	
C24	8493	COND CMS 1206 100N 50V 20% X7R	
C25	8493	COND CMS 1206 100N 50V 20% X7R	
C26	8493	COND CMS 1206 100N 50V 20% X7R	
C27	8493	COND CMS 1206 100N 50V 20% X7R	
C28	8493	COND CMS 1206 100N 50V 20% X7R	
C29	8493	COND CMS 1206 100N 50V 20% X7R	
C30	8493	COND CMS 1206 100N 50V 20% X7R	
C31	8493	COND CMS 1206 100N 50V 20% X7R	
C32	8493	COND CMS 1206 100N 50V 20% X7R	
C33	8493	COND CMS 1206 100N 50V 20% X7R	
C34	8493	COND CMS 1206 100N 50V 20% X7R	
C35	8493	COND CMS 1206 100N 50V 20% X7R	
C36	8493	COND CMS 1206 100N 50V 20% X7R	
C37	8493	COND CMS 1206 100N 50V 20% X7R	
C38	8493	COND CMS 1206 100N 50V 20% X7R	
C39	8493	COND CMS 1206 100N 50V 20% X7R	
C40	8493	COND CMS 1206 100N 50V 20% X7R	
C41	8493	COND CMS 1206 100N 50V 20% X7R	
C42	8493	COND CMS 1206 100N 50V 20% X7R	
C43	8493	COND CMS 1206 100N 50V 20% X7R	
C44	8493	COND CMS 1206 100N 50V 20% X7R	
C45	8493	COND CMS 1206 100N 50V 20% X7R	
C46	8493	COND CMS 1206 100N 50V 20% X7R	
C47	8493	COND CMS 1206 100N 50V 20% X7R	
C48	8493	COND CMS 1206 100N 50V 20% X7R	
C49	8493	COND CMS 1206 100N 50V 20% X7R	
C50	8493	COND CMS 1206 100N 50V 20% X7R	
C51	8493	COND CMS 1206 100N 50V 20% X7R	
C52	8493	COND CMS 1206 100N 50V 20% X7R	
C53	8493	COND CMS 1206 100N 50V 20% X7R	
CE01	1983	COND CHIMI RAD 22U 50V 7X7 R5	

+-- Value Tab Head -----+			
Part:W1301861 Drawing:W4S131402B		Copy In Part:	Draw:
Desc:BLA CONTROL BOARD 2		ECL:3	Modified:21/01/97 By:MN
+-- Value Tab -----+			
Pos.	Component	Local Description	
CE02	1983	COND CHIMI RAD 22U 50V 7X7 R5	
CE03	1983	COND CHIMI RAD 22U 50V 7X7 R5	
CE04	1983	COND CHIMI RAD 22U 50V 7X7 R5	
CE05	1983	COND CHIMI RAD 22U 50V 7X7 R5	
CE06	1983	COND CHIMI RAD 22U 50V 7X7 R5	
CE07	1983	COND CHIMI RAD 22U 50V 7X7 R5	
CE08	3746	COND CHIMI RAD 10U 35V 5X7 R5	
CE09	3746	COND CHIMI RAD 10U 35V 5X7 R5	
CE10	3746	COND CHIMI RAD 10U 35V 5X7 R5	
CE11	3746	COND CHIMI RAD 10U 35V 5X7 R5	
CE12	3746	COND CHIMI RAD 10U 35V 5X7 R5	
CE13	3746	COND CHIMI RAD 10U 35V 5X7 R5	
CE14	3746	COND CHIMI RAD 10U 35V 5X7 R5	
CE15	1979	COND CHIMI RAD 47U 25V 7X7 R5	
CE16	34738	COND CHIMI RAD 4.7U 35V 4X7 R5	
CI01	W1356501	CI B-LA CONTROL BOARD 2	
D01	22029	DIODE CMS BAS32L SOD80	
D02	22029	DIODE CMS BAS32L SOD80	
D03	22029	DIODE CMS BAS32L SOD80	
D04	31145	DIODE 1N914	
D05	31145	DIODE 1N914	
D06	22029	DIODE CMS BAS32L SOD80	
D07	22029	DIODE CMS BAS32L SOD80	
D08	22029	DIODE CMS BAS32L SOD80	
D09	22029	DIODE CMS BAS32L SOD80	
D10	22029	DIODE CMS BAS32L SOD80	
D11	22029	DIODE CMS BAS32L SOD80	
D12	22029	DIODE CMS BAS32L SOD80	
DZ01	33716	DIODE Z BZX84C 6V2 300MW SOT23	
DZ02	33716	DIODE Z BZX84C 6V2 300MW SOT23	
ICSU02	4284	IC SUPPORT DIL14 TULIPE	
ICSU03	4284	IC SUPPORT DIL14 TULIPE	
ICSU04	4285	IC SUPPORT DIL8 TULIPE	
ICSU05	546	IC SUPPORT DIL16 TULIPE	
ICSU06	4284	IC SUPPORT DIL14 TULIPE	
ICSU07	4285	IC SUPPORT DIL8 TULIPE	
ICSU08	546	IC SUPPORT DIL16 TULIPE	
ICSU09	4284	IC SUPPORT DIL14 TULIPE	
ICSU10	33153	IC SUPPORT DIL10 TO100	
ICSU11	4284	IC SUPPORT DIL14 TULIPE	
ICSU12	4285	IC SUPPORT DIL8 TULIPE	
ICSU13	33153	IC SUPPORT DIL10 TO100	
ICSU14	33153	IC SUPPORT DIL10 TO100	
ICSU15	546	IC SUPPORT DIL16 TULIPE	
ICSU16	546	IC SUPPORT DIL16 TULIPE	
ICSU17	546	IC SUPPORT DIL16 TULIPE	
ICSU18	4285	IC SUPPORT DIL8 TULIPE	
ICSU19	4285	IC SUPPORT DIL8 TULIPE	
ICSU21	546	IC SUPPORT DIL16 TULIPE	
ICSU22	16049	IC SUPPORT PLCC68	
J01	73528	CN M 4 D PRT 41761 R3.96MM	
J02	34869	CN M 5 D PRT 6410	
J03	35464	CN M 6 D PRT 6410	
J04	1235	CN COAX SMB M D PRT	
J05	1235	CN COAX SMB M D PRT	
J06	1235	CN COAX SMB M D PRT	

BLA Control Board 2

+-- Value Tab Head -----+--			
Part:W1301861 Drawing:W4S131402B		Copy In Part:	Draw:
Desc:BLA CONTROL BOARD 2		ECL:3	Modified:21/01/97 By:MN
+-- Value Tab -----+--			
Pos.	Component	Local Description	
J07	1235	CN COAX SMB M D PRT	
J08	1235	CN COAX SMB M D PRT	
J09	1235	CN COAX SMB M D PRT	
J10	1235	CN COAX SMB M D PRT	
J11	15755	CN M 14 D PRT TRANSITION REDUI	
J12	22671	CN M 16 D PRT TRANSITION REDUI	
J13	5612	CN M 34 D PRT TRANSI.REDUI 3.2	
J14	1235	CN COAX SMB M D PRT	
J15	1235	CN COAX SMB M D PRT	
J16	1235	CN COAX SMB M D PRT	
J17	1235	CN COAX SMB M D PRT	
J18	35013	CN M 4 D PRT 6410	
JP01	51127	CN M 36 D PRT BARSIL R2.54 H8	
JP02	51127	CN M 36 D PRT BARSIL R2.54 H8	
JP03	51127	CN M 36 D PRT BARSIL R2.54 H8	
JP04	51127	CN M 36 D PRT BARSIL R2.54 H8	
JP05	51127	CN M 36 D PRT BARSIL R2.54 H8	
L01	30609	SELF 10UH 0.33A	
L02	30609	SELF 10UH 0.33A	
L03	2029	SELF AX CHOC 2.5SP GAINE THERM	
L04	30609	SELF 10UH 0.33A	
LD01	366	OPTO LED 3MM D SOUD VR	
LD02	366	OPTO LED 3MM D SOUD RG	
LD03	366	OPTO LED 3MM D SOUD RG	
LD04	366	OPTO LED 3MM D SOUD RG	
LD05	366	OPTO LED 3MM D SOUD RG	
LD06	366	OPTO LED 3MM D SOUD RG	
LD07	366	OPTO LED 3MM D SOUD RG	
LD08	366	OPTO LED 3MM D SOUD RG	
LD09	366	OPTO LED 3MM D SOUD RG	
LD10	366	OPTO LED 3MM D SOUD RG	
LDSU01	34992	TRANS SUPPORT TO18	
LDSU02	34992	TRANS SUPPORT TO18	
LDSU03	34992	TRANS SUPPORT TO18	
LDSU04	34992	TRANS SUPPORT TO18	
LDSU05	34992	TRANS SUPPORT TO18	
LDSU06	34992	TRANS SUPPORT TO18	
LDSU07	34992	TRANS SUPPORT TO18	
LDSU08	34992	TRANS SUPPORT TO18	
LDSU09	34992	TRANS SUPPORT TO18	
LDSU10	34992	TRANS SUPPORT TO18	
R001	20737	RES CMS 1K 1% 0.25W 1206	
R002	51286	RES CMS 243 1% 0.25W 1206	
R003	20741	RES CMS 2.21K 1% 0.25W 1206	
R004	20741	RES CMS 2.21K 1% 0.25W 1206	
R005	20741	RES CMS 2.21K 1% 0.25W 1206	
R006	20741	RES CMS 2.21K 1% 0.25W 1206	
R007	20730	RES CMS 332 1% 0.25W 1206	
R008	20730	RES CMS 332 1% 0.25W 1206	
R009	20730	RES CMS 332 1% 0.25W 1206	
R010	20730	RES CMS 332 1% 0.25W 1206	
R011	20750	RES CMS 10K 1% 0.25W 1206	
R012	73283	RES CMS 47.5 1% 0.25W 1206	
R013	20730	RES CMS 332 1% 0.25W 1206	
R014	20724	RES CMS 100 1% 0.25W 1206	
R015	20724	RES CMS 100 1% 0.25W 1206	

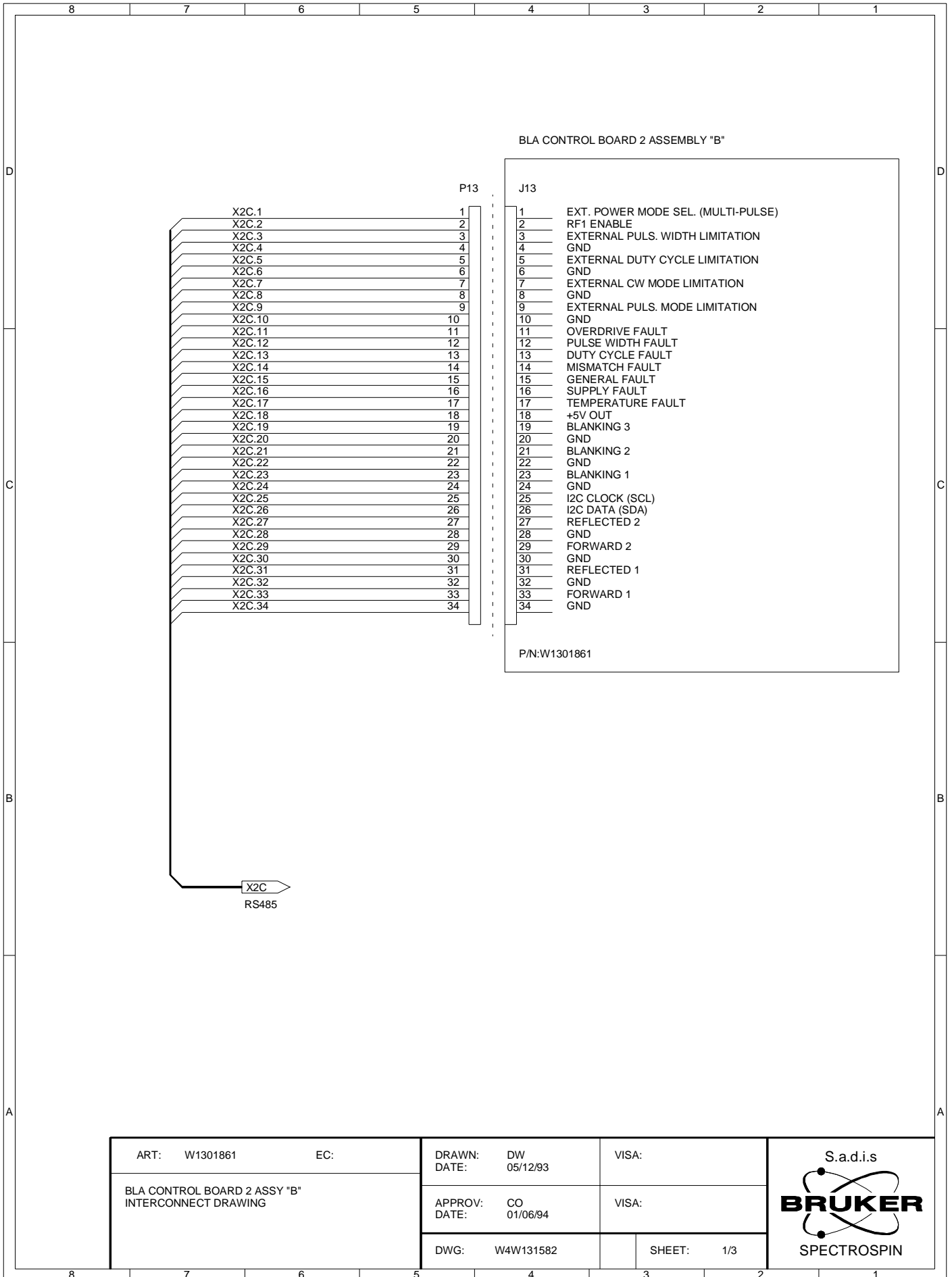
+-- Value Tab Head -----+			
Part:W1301861 Drawing:W4S131402B		Copy In Part:	Draw:
Desc:BLA CONTROL BOARD 2		ECL:3	Modified:21/01/97 By:MN
+-- Value Tab -----+			
Pos.	Component	Local Description	
R016	20724	RES CMS	100 1% 0.25W 1206
R017	20745	RES CMS	4.7K 1% 0.25W 1206
R018	20745	RES CMS	4.7K 1% 0.25W 1206
R019	20745	RES CMS	4.7K 1% 0.25W 1206
R020	20730	RES CMS	332 1% 0.25W 1206
R021	20730	RES CMS	332 1% 0.25W 1206
R022	20730	RES CMS	332 1% 0.25W 1206
R023	20730	RES CMS	332 1% 0.25W 1206
R024	20730	RES CMS	332 1% 0.25W 1206
R025	73283	RES CMS	47.5 1% 0.25W 1206
R026	20737	RES CMS	1K 1% 0.25W 1206
R027	20745	RES CMS	4.7K 1% 0.25W 1206
R028	20750	RES CMS	10K 1% 0.25W 1206
R029	20737	RES CMS	1K 1% 0.25W 1206
R030	20750	RES CMS	10K 1% 0.25W 1206
R031	20750	RES CMS	10K 1% 0.25W 1206
R032	20737	RES CMS	1K 1% 0.25W 1206
R033	20724	RES CMS	100 1% 0.25W 1206
R034	20724	RES CMS	100 1% 0.25W 1206
R035	51748	RES CMS	475K 1% 0.25W 1206
R036	53697	RES CMS	90.9K 1% 0.25W 1206
R037	20750	RES CMS	10K 1% 0.25W 1206
R038	20739	RES CMS	1.5K 1% 0.25W 1206
R039	20737	RES CMS	1K 1% 0.25W 1206
R040	21327	RES CMS	22.1K 1% 0.25W 1206
R041	20730	RES CMS	332 1% 0.25W 1206
R042	20737	RES CMS	1K 1% 0.25W 1206
R043	20745	RES CMS	4.7K 1% 0.25W 1206
R044	20750	RES CMS	10K 1% 0.25W 1206
R045	20737	RES CMS	1K 1% 0.25W 1206
R046	20750	RES CMS	10K 1% 0.25W 1206
R047	20750	RES CMS	10K 1% 0.25W 1206
R048	20737	RES CMS	1K 1% 0.25W 1206
R049	20724	RES CMS	100 1% 0.25W 1206
R050	20724	RES CMS	100 1% 0.25W 1206
R051	20745	RES CMS	4.7K 1% 0.25W 1206
R052	20750	RES CMS	10K 1% 0.25W 1206
R053	20750	RES CMS	10K 1% 0.25W 1206
R054	20750	RES CMS	10K 1% 0.25W 1206
R055	21348	RES CMS	1.21M 1% 0.25W 1206
R056	20745	RES CMS	4.7K 1% 0.25W 1206
R057	20737	RES CMS	1K 1% 0.25W 1206
R058	20730	RES CMS	332 1% 0.25W 1206
R059	21339	RES CMS	221K 1% 0.25W 1206
R060	20750	RES CMS	10K 1% 0.25W 1206
R061	73283	RES CMS	47.5 1% 0.25W 1206
R062	20730	RES CMS	332 1% 0.25W 1206
R063	20730	RES CMS	332 1% 0.25W 1206
R064	20745	RES CMS	4.7K 1% 0.25W 1206
R065	20750	RES CMS	10K 1% 0.25W 1206
R066	20747	RES CMS	6.81K 1% 0.25W 1206
R067	20737	RES CMS	1K 1% 0.25W 1206
R068	20750	RES CMS	10K 1% 0.25W 1206
R069	20750	RES CMS	10K 1% 0.25W 1206
R070	20737	RES CMS	1K 1% 0.25W 1206
R071	20724	RES CMS	100 1% 0.25W 1206

+-- Value Tab Head -----+			
Part:W1301861 Drawing:W4S131402B		Copy In Part:	Draw:
Desc:BLA CONTROL BOARD 2		ECL:3	Modified:21/01/97 By:MN
+-- Value Tab -----+			
Pos.	Component	Local Description	
R129	20730	RES CMS 332 1% 0.25W 1206	
R130	21339	RES CMS 221K 1% 0.25W 1206	
R131	20730	RES CMS 332 1% 0.25W 1206	
R132	20730	RES CMS 332 1% 0.25W 1206	
R133	20730	RES CMS 332 1% 0.25W 1206	
R134	20724	RES CMS 100 1% 0.25W 1206	
R135	20745	RES CMS 4.7K 1% 0.25W 1206	
R136	20730	RES CMS 332 1% 0.25W 1206	
R137	20730	RES CMS 332 1% 0.25W 1206	
R138	73283	RES CMS 47.5 1% 0.25W 1206	
R139	73283	RES CMS 47.5 1% 0.25W 1206	
R140	20724	RES CMS 100 1% 0.25W 1206	
R141	20745	RES CMS 4.7K 1% 0.25W 1206	
R142	20724	RES CMS 100 1% 0.25W 1206	
R143	20745	RES CMS 4.7K 1% 0.25W 1206	
R144	20745	RES CMS 4.7K 1% 0.25W 1206	
R145	20745	RES CMS 4.7K 1% 0.25W 1206	
R146	20711	RES CMS 10 1% 0.25W 1206	
R147	20711	RES CMS 10 1% 0.25W 1206	
R148	73283	RES CMS 47.5 1% 0.25W 1206	
R149	20724	RES CMS 100 1% 0.25W 1206	
R150	20745	RES CMS 4.7K 1% 0.25W 1206	
R151	73283	RES CMS 47.5 1% 0.25W 1206	
R152	20724	RES CMS 100 1% 0.25W 1206	
R153	20745	RES CMS 4.7K 1% 0.25W 1206	
R154	20745	RES CMS 4.7K 1% 0.25W 1206	
R155	20745	RES CMS 4.7K 1% 0.25W 1206	
R156	20711	RES CMS 10 1% 0.25W 1206	
R157	20711	RES CMS 10 1% 0.25W 1206	
R158	20745	RES CMS 4.7K 1% 0.25W 1206	
R159	20745	RES CMS 4.7K 1% 0.25W 1206	
R160	20727	RES CMS 182 1% 0.25W 1206	
R161	20727	RES CMS 182 1% 0.25W 1206	
R162	20750	RES CMS 10K 1% 0.25W 1206	
R163	20750	RES CMS 10K 1% 0.25W 1206	
R164	20750	RES CMS 10K 1% 0.25W 1206	
R165	20750	RES CMS 10K 1% 0.25W 1206	
R166	21352	RES CMS 0 1% 0.25W 1206	
R167	21352	RES CMS 0 1% 0.25W 1206	
R168	21352	RES CMS 0 1% 0.25W 1206	
R169	20741	RES CMS 2.21K 1% 0.25W 1206	
R170	21339	RES CMS 221K 1% 0.25W 1206	
RAD01	39793	RADIAT 6079B-SM3	
RS01	53228	RES RES 1.5KX5 2% SIL6	
RS02	51429	RES RES 100KX4 2% SIL5	
RV01	34810	RES AJUST 20K 0.5W 25T V	
RV02	34811	RES AJUST 50K 0.5W 25T V	
RV03	34811	RES AJUST 50K 0.5W 25T V	
RV04	34811	RES AJUST 50K 0.5W 25T V	
RV05	34811	RES AJUST 50K 0.5W 25T V	
RV06	34810	RES AJUST 20K 0.5W 25T V	
RV07	34810	RES AJUST 20K 0.5W 25T V	
RV08	34810	RES AJUST 20K 0.5W 25T V	
RV09	34810	RES AJUST 20K 0.5W 25T V	
RV10	34810	RES AJUST 20K 0.5W 25T V	
RV11	34810	RES AJUST 20K 0.5W 25T V	

BLA Control Board 2


Value Tab Head			
Part:W1301861 Drawing:W4S131402B		Copy In Part:	Draw:
Desc:BLA CONTROL BOARD 2		ECL:3	Modified:21/01/97 By:MN
Value Tab	Component	Local Description	
RV12	34810	RES AJUST	20K 0.5W 25T V
RV13	34811	RES AJUST	50K 0.5W 25T V
RV14	34810	RES AJUST	20K 0.5W 25T V
RV15	34810	RES AJUST	20K 0.5W 25T V
RV16	34811	RES AJUST	50K 0.5W 25T V
RV17	34811	RES AJUST	50K 0.5W 25T V
RV18	34811	RES AJUST	50K 0.5W 25T V
T01	34607	TRANS BS170	N VMOS TO92
T02	34607	TRANS BS170	N VMOS TO92
T03	34607	TRANS BS170	N VMOS TO92
TP01	2083	ACCBL PICOT	RND D=1MM
TP02	2083	ACCBL PICOT	RND D=1MM
TP03	2083	ACCBL PICOT	RND D=1MM
TP04	2083	ACCBL PICOT	RND D=1MM
TP05	2083	ACCBL PICOT	RND D=1MM
TP06	2083	ACCBL PICOT	RND D=1MM
TP07	2083	ACCBL PICOT	RND D=1MM
TP08	2083	ACCBL PICOT	RND D=1MM
TP09	2083	ACCBL PICOT	RND D=1MM
TP10	2083	ACCBL PICOT	RND D=1MM
TP11	2083	ACCBL PICOT	RND D=1MM
TP12	2083	ACCBL PICOT	RND D=1MM
TP13	2083	ACCBL PICOT	RND D=1MM
TP14	2083	ACCBL PICOT	RND D=1MM
TP15	2083	ACCBL PICOT	RND D=1MM
TP16	2083	ACCBL PICOT	RND D=1MM
U01	452	IC 317/VREG	LM317T TO220
U02	5799	IC 339/OP COMP	LM339 PDIP14
U03	56310	IC 404/OP OPA404KP	QUAD DIFET
U04	289	IC 311/OP COMP	LM311 PDIP8
U05	5951	IC 74123/PC74HC123P	PDIP
U06	9288	IC 074/OP TL074CN	DIL 14
U07	289	IC 311/OP COMP	LM311 PDIP8
U08	5951	IC 74123/PC74HC123P	PDIP
U09	56310	IC 404/OP OPA404KP	QUAD DIFET
U10	56354	IC 8013/PAD ICL8013CCTZ	MULT
U11	5799	IC 339/OP COMP	LM339 PDIP14
U12	9001	IC 356/OP LF356N	PDIP 8
U13	56354	IC 8013/PAD ICL8013CCTZ	MULT
U14	56354	IC 8013/PAD ICL8013CCTZ	MULT
U15	5951	IC 74123/PC74HC123P	PDIP
U16	56320	IC 4053/MUX MM74HC4053	
U17	5951	IC 74123/PC74HC123P	PDIP
U18	56292	IC 428/DRV TSC428CPA	DIP8
U19	56292	IC 428/DRV TSC428CPA	DIP8
U20	22952	IC 24022/E2PR X24022S8	SO8
U21	5951	IC 74123/PC74HC123P	PDIP
U22	56429	IC 1810/EPLD EP1810LC25	PLCC68

Figure 7.11. Interconnect Drawing ASSY «B» Wiring Diagram



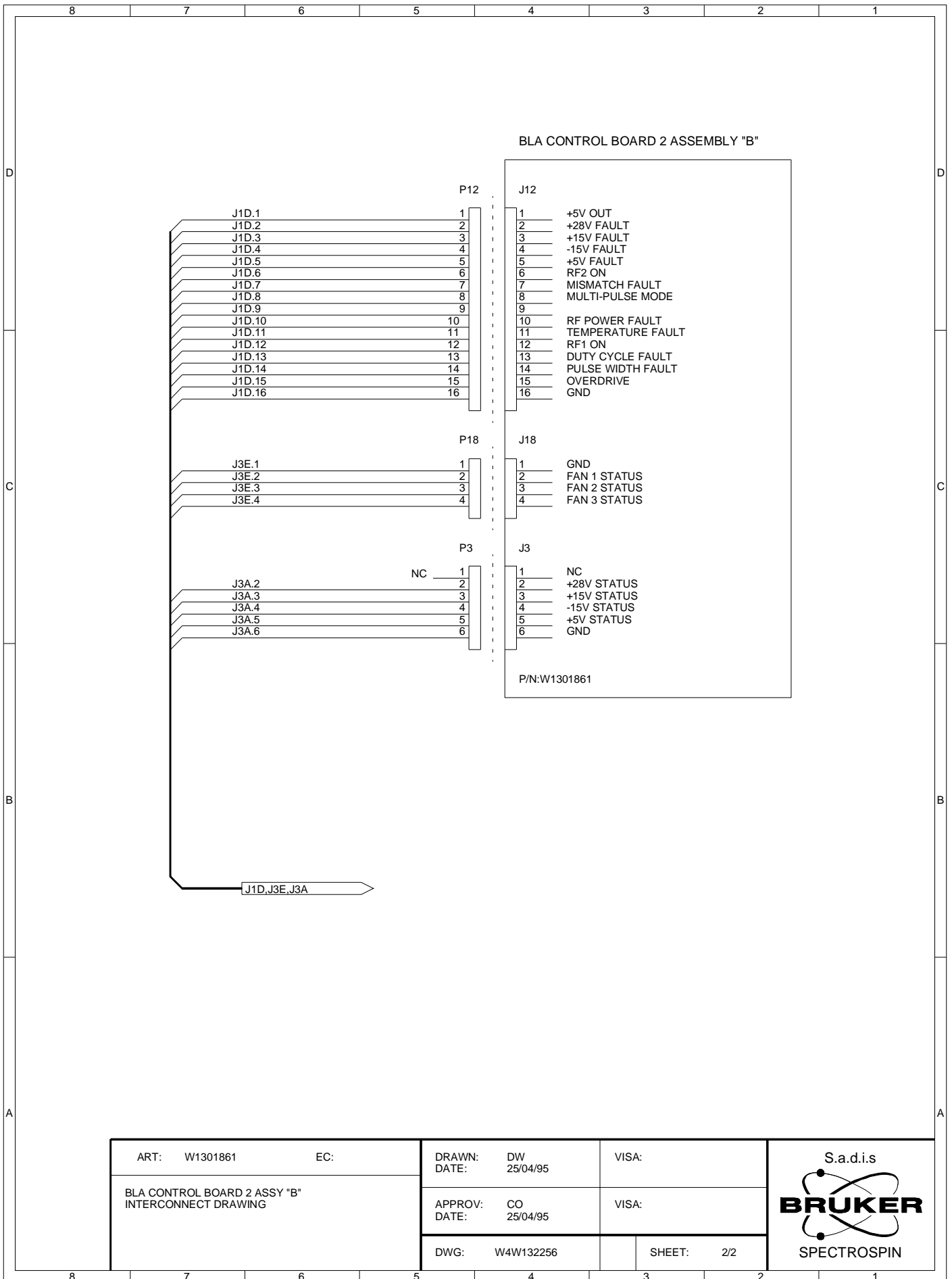
ART: W1301861	EC:	DRAWN: DW DATE: 05/12/93	VISA:
BLA CONTROL BOARD 2 ASSY "B" INTERCONNECT DRAWING		APPROV: CO DATE: 01/06/94	VISA:
		DWG: W4W131582	SHEET: 1/3

S.a.d.i.s

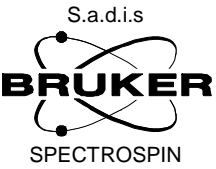


BRUKER
SPECTROSPIN

Figure 7.12. Interconnect Drawing ASSY «B» Wiring Diagram



ART: W1301861	EC:	DRAWN: DW DATE: 25/04/95	VISA:
BLA CONTROL BOARD 2 ASSY "B" INTERCONNECT DRAWING		APPROV: CO DATE: 25/04/95	VISA:
		DWG: W4W132256	SHEET: 2/2



BLA Control Board Extension

8

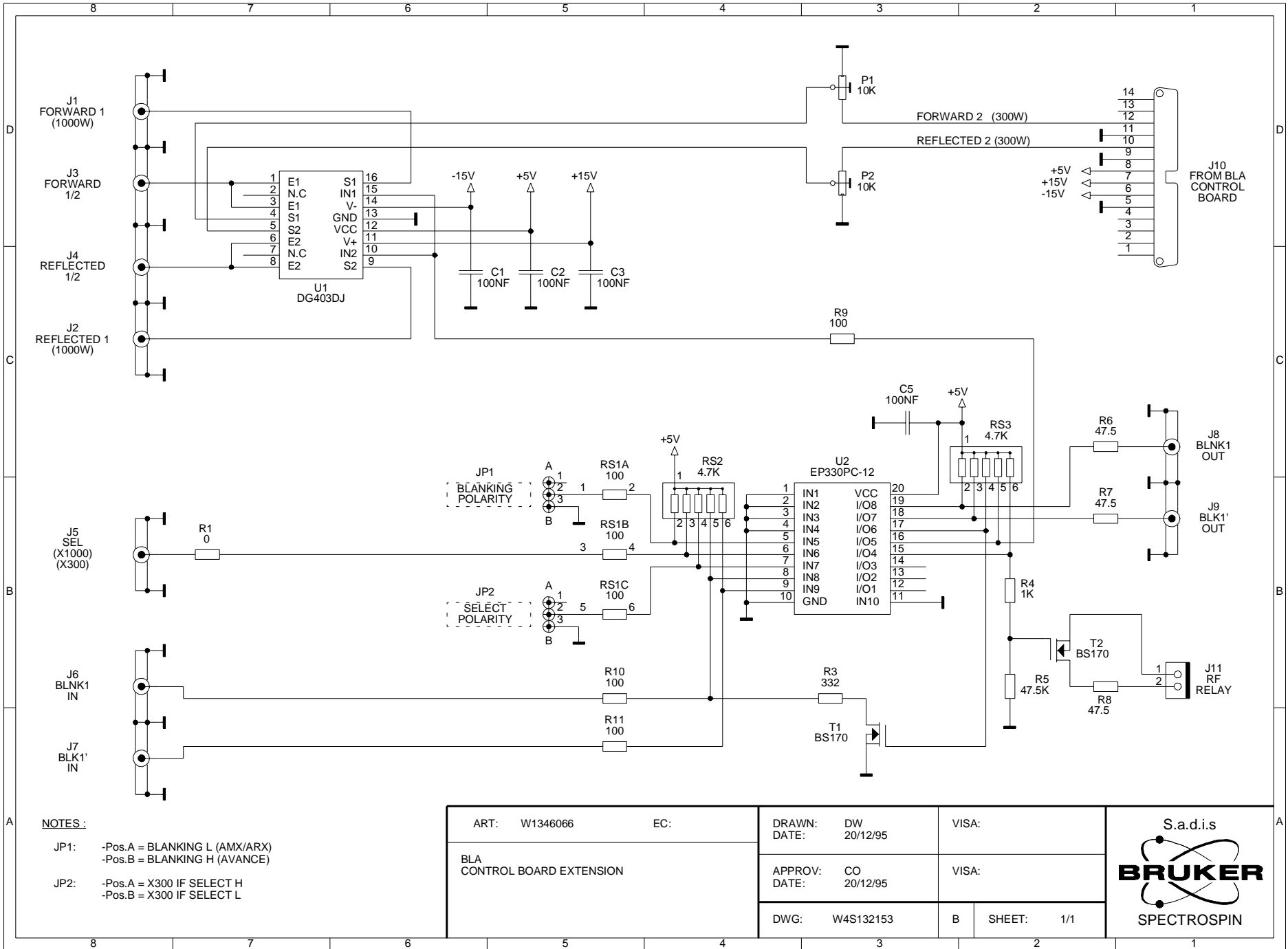


Figure 8.1. Control Board Extension Schematic

NOTES:

- JP1: -Pos.A = BLANKING L (AMX/ARX)
-Pos.B = BLANKING H (AVANCE)
- JP2: -Pos.A = X300 IF SELECT H
-Pos.B = X300 IF SELECT L

ART: W1346066	EC:	DRAWN: DW	VISA:	
BLA CONTROL BOARD EXTENSION		DATE: 20/12/95		
		APPROV: CO	VISA:	
		DATE: 20/12/95		
DWG: W4S132153		B	SHEET: 1/1	

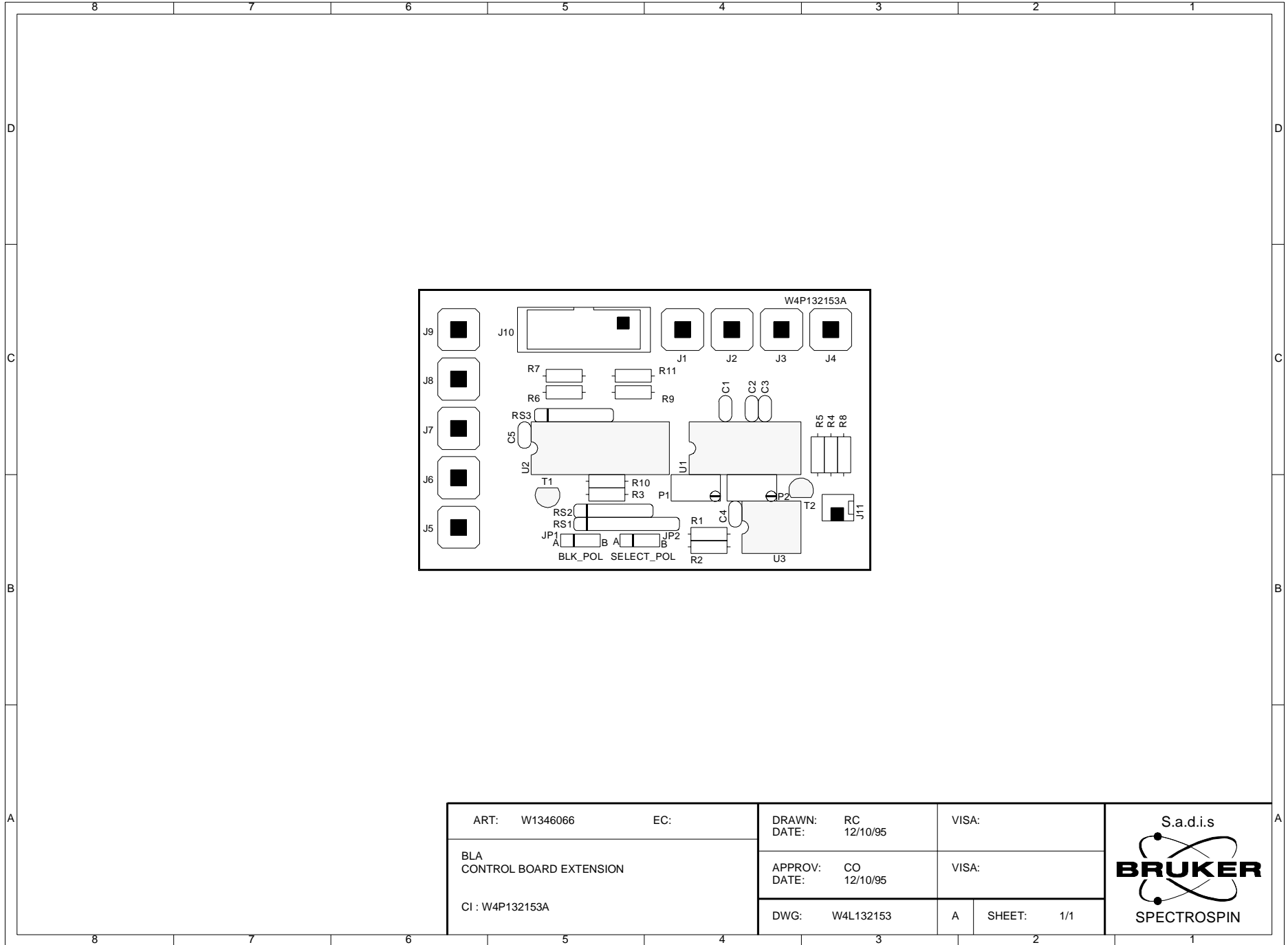


Figure 8.2. Control Board Extension Location

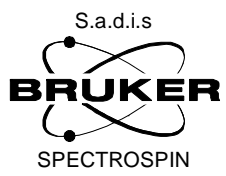
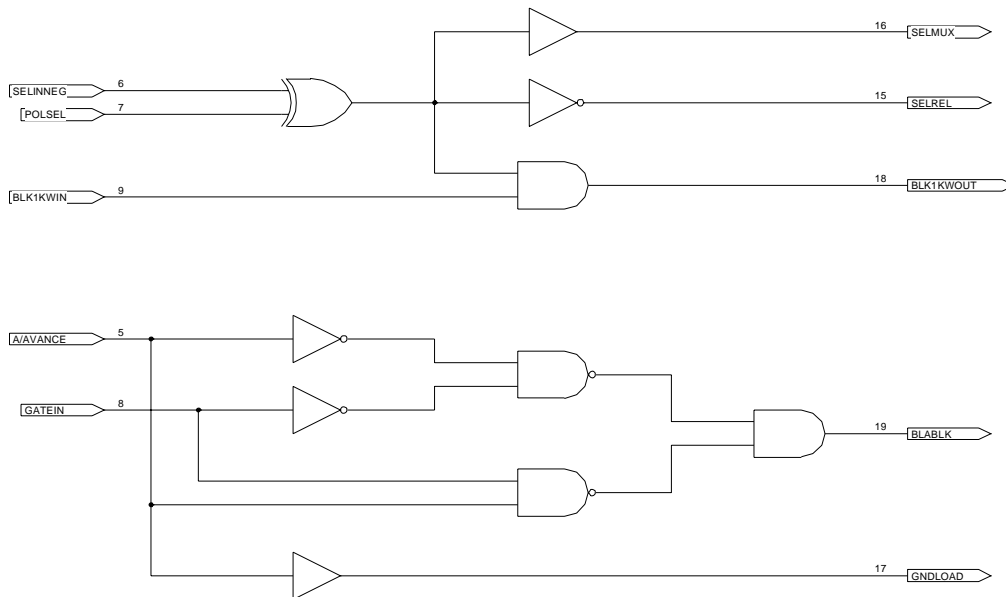
ART: W1346066	EC:	DRAWN: RC	VISA:	
BLA CONTROL BOARD EXTENSION		DATE: 12/10/95		
CI : W4P132153A		APPROV: CO	VISA:	
		DATE: 12/10/95		
		DWG: W4L132153	A SHEET: 1/1	

Figure 8.3. Pal CBE01/01 Hardware Schematic

CBE01/01
06/07/95

EP330PC-12			
GND	1	IN1	VCC
GND	2	IN2	I/O8
GND	3	IN3	I/O7
GND	4	IN4	I/O6
A/AVANCE	5	IN5	I/O5
SELINNEG	6	IN6	I/O4
POLSEL	7	IN7	I/O3
GATEIN	8	IN8	I/O2
BLK1KWIN	9	IN9	I/O1
GND	10	GND	IN10
			20 VCC
			19 BLBLK
			18 BLK1KWOUT
			17 GNDLOAD
			16 SELMUX
			15 SELREL
			14 RESERVED
			13 RESERVED
			12 RESERVED
			11 GND



ART: W1356647	EC: 01	DRAWN: DW	VISA:
IC 330/CONTROL BOARD EXTENSION		DATE: 06/07/95	
CBE01/01		APPROV: PHB	VISA:
		DATE: 07/07/95	
		DWG: W4D132154	SHEET: 1/1



Value Table

```

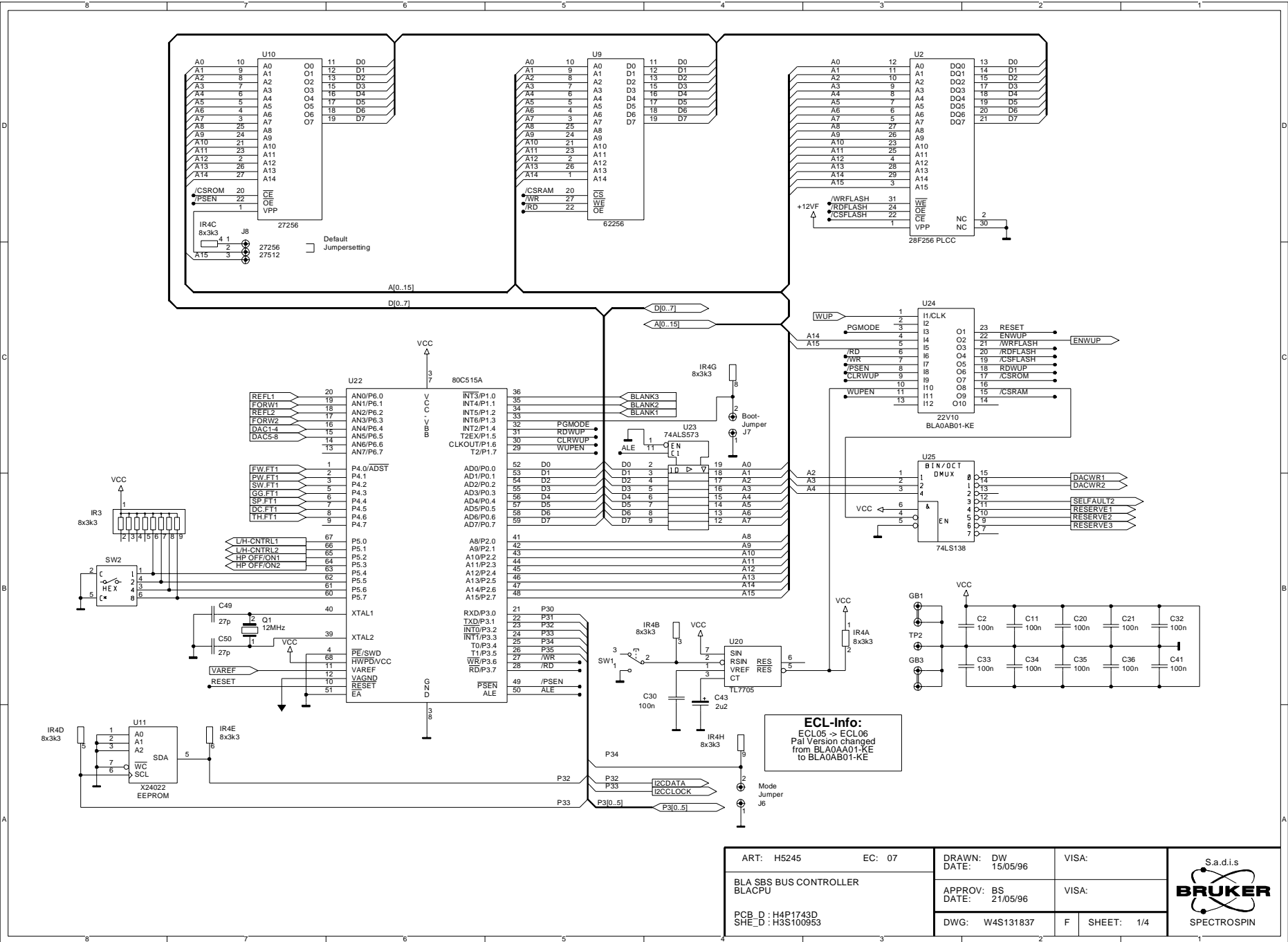
+-- Value Tab Head -----+
| Part:W1346066 Drawing:W4S132153B          Copy In Part:          Draw:          |
| Desc:BLA EXTENSION CIRCUIT CONTROL  ECL:3      Modified:29/04/97      By:MN          |
+-- Value Tab -----+
|      Pos.          Component          Local Description          |
|      C01          37167              COND CERM 100N 100V 10% X7R |
|      C02          37167              COND CERM 100N 100V 10% X7R |
|      C03          37167              COND CERM 100N 100V 10% X7R |
|      C05          37167              COND CERM 100N 100V 10% X7R |
|      CI01         W1356646          BLA EXTENSION CIRCUIT CONTROL |
|      ICSU01       546              IC SUPPORT DIL16 TULIPE      |
|      ICSU02       9276              IC SUPPORT DIL20 TULIPE      |
|      J01          1235              CN COAX SMB M D PRT          |
|      J02          1235              CN COAX SMB M D PRT          |
|      J03          1235              CN COAX SMB M D PRT          |
|      J04          1235              CN COAX SMB M D PRT          |
|      J05          1235              CN COAX SMB M D PRT          |
|      J06          1235              CN COAX SMB M D PRT          |
|      J07          1235              CN COAX SMB M D PRT          |
|      J08          1235              CN COAX SMB M D PRT          |
|      J09          1235              CN COAX SMB M D PRT          |
|      J10          15755             CN M 14 D PRT TRANSITION REDUI |
|      J11          34889             CN M 2 D PRT 6410            |
|      JP01         W1204337          CN M 3 D PRT BARSIL R2.54 H8  |
|      JP02         W1204337          CN M 3 D PRT BARSIL R2.54 H8  |
|      JP1CAV       3033              ACCBL CAVALIER F 2.54MM      |
|      JP2CAV       3033              ACCBL CAVALIER F 2.54MM      |
|      P01          9613              RES AJUST 10K 0.5W 25T V     |
|      P02          9613              RES AJUST 10K 0.5W 25T V     |
|      R01          4446              RES MET 0 1% 0.6W           |
|      R03          1004              RES MET 332 1% 0.6W 50PPM    |
|      R04          1010              RES MET 1K 1% 0.6W 50PPM     |
|      R05          1030              RES MET 47.5K 1% 0.6W 50PPM  |
|      R06          994              RES MET 47.5 1% 0.6W 50PPM   |
|      R07          994              RES MET 47.5 1% 0.6W 50PPM   |
|      R08          994              RES MET 47.5 1% 0.6W 50PPM   |
|      R09          998              RES MET 100 1% 0.6W 50PPM    |
|      R10          998              RES MET 100 1% 0.6W 50PPM    |
|      R11          998              RES MET 100 1% 0.6W 50PPM    |
|      RS01         16168             RES RES 100X4 2% SIL8        |
|      RS02         9818              RES RES 4.7KX5 2% SIL6        |
|      RS03         9818              RES RES 4.7KX5 2% SIL6        |
|      T01          34607             TRANS BS170 N VMOS TO92      |
|      T02          34607             TRANS BS170 N VMOS TO92      |
|      U01          30612             IC 403/MUX DG403DJ PDIP      |
|      U02          W1356647          IC 330/EXTENS. CIRCUIT CONTROL |
+-----+

```


BLA SBS Bus Controller

9

Figure 9.1. BLA CPU Schematic



ART: H5245	EC: 07	DRAWN: DW DATE: 15/05/96	VISA:	
BLA SBS BUS CONTROLLER BLACPU		APPROV: BS DATE: 21/05/96	VISA:	
PCB_D : H4P1743D SHE_D : H3S100953		DWG: W4S131837	F SHEET: 1/4	

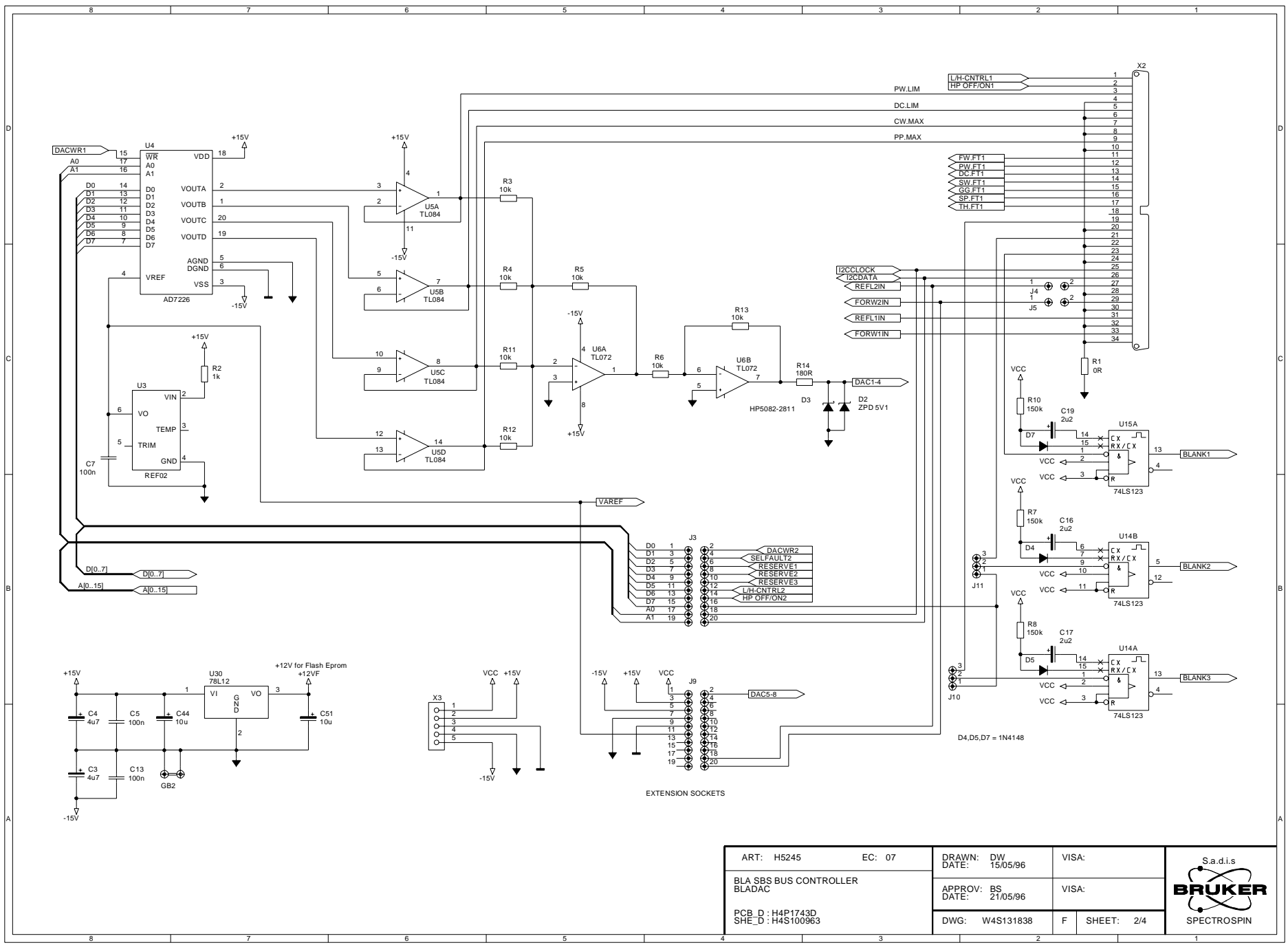
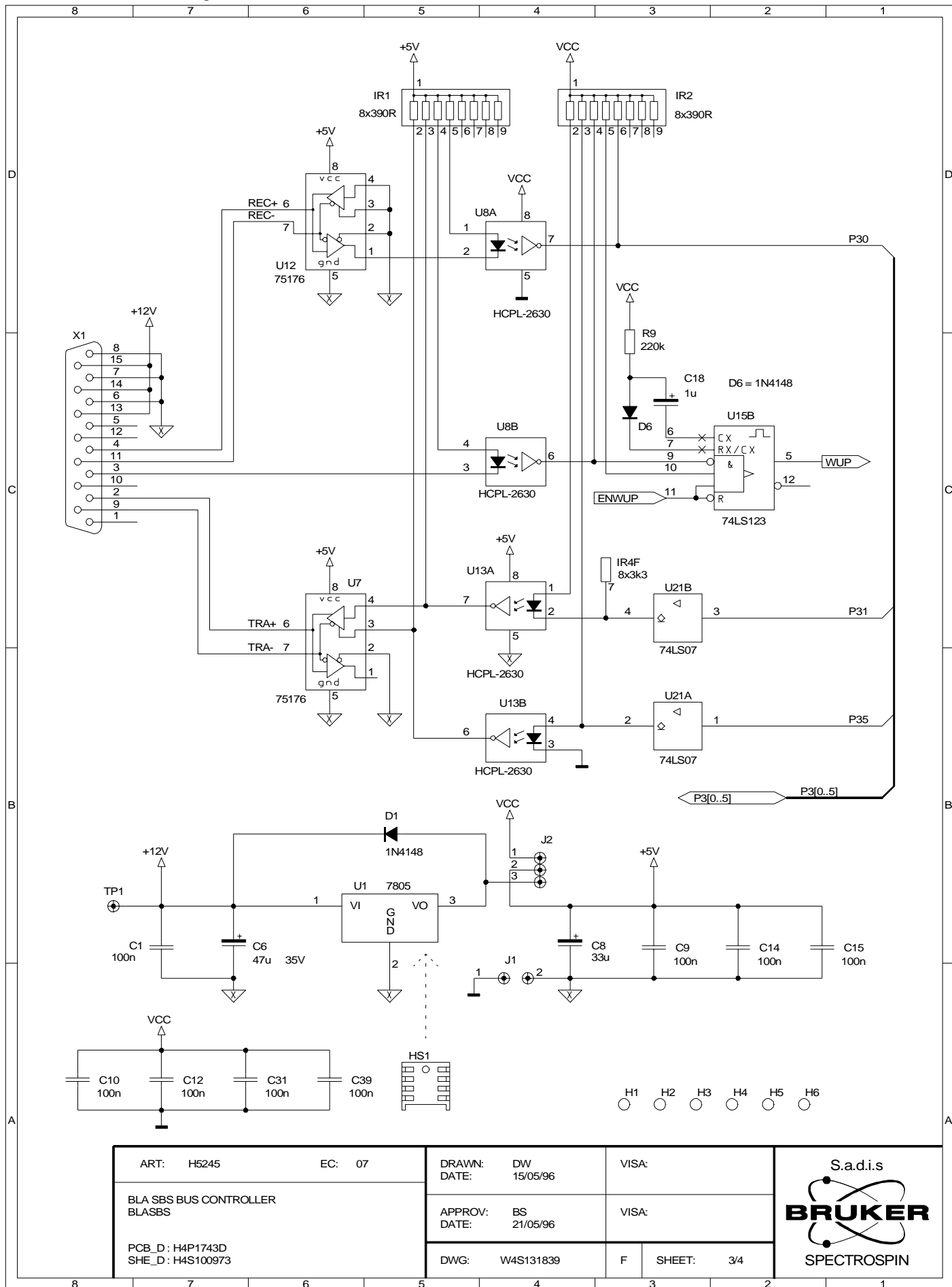


Figure 9.2. BLA DAC Schematic

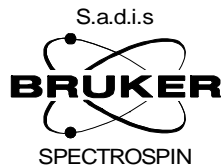
ART: H5245	EC: 07	DRAWN: DW DATE: 15/05/96	VISA:
BLA SBS BUS CONTROLLER BLADAC		APPROV: BS DATE: 21/05/96	VISA:
PCB_D : H4P1743D SHE_D : H4S100963		DWG: W4S131838	F SHEET: 2/4

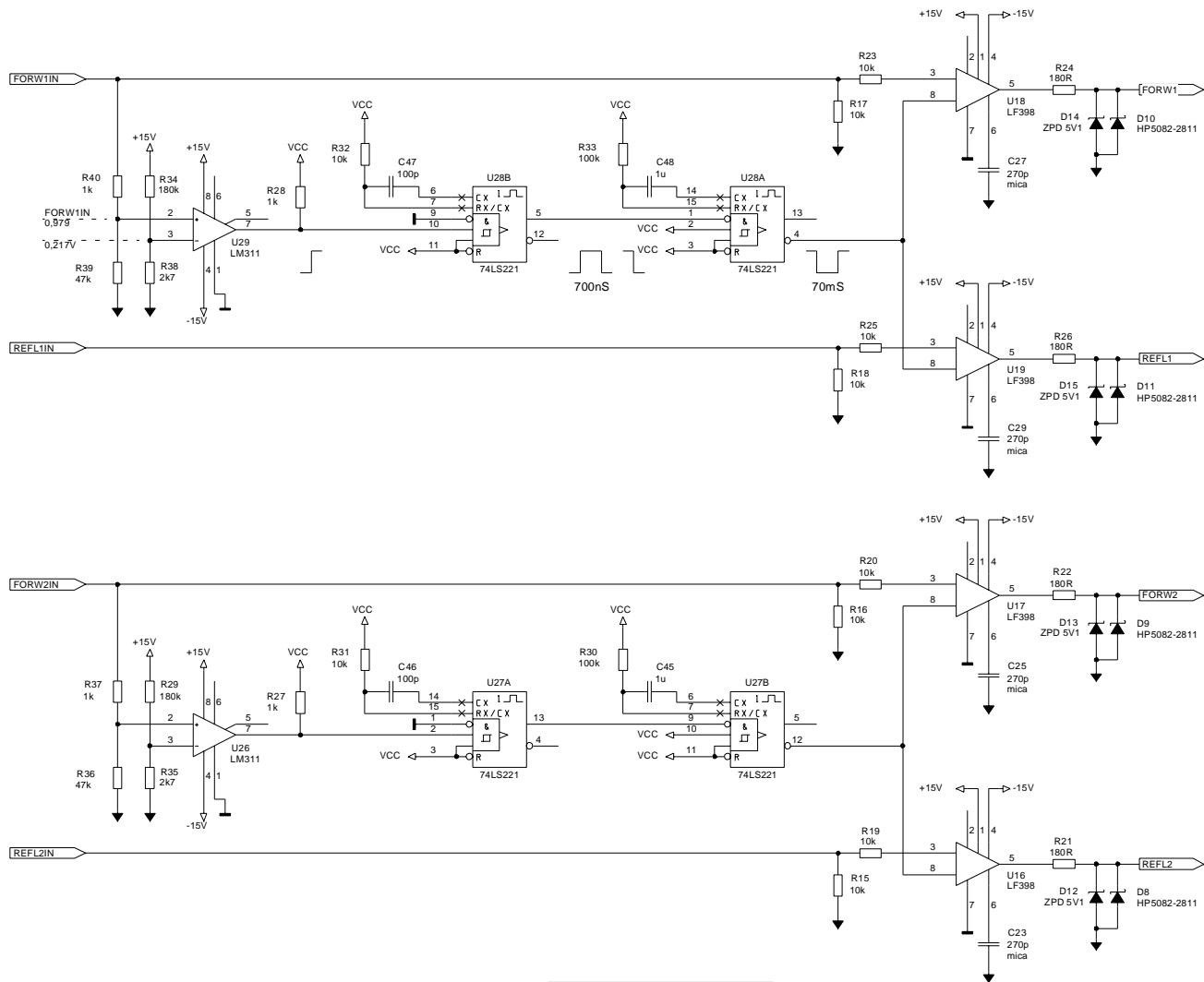


Figure 9.3. BLA SBS Schematic



ART: H5245	EC: 07	DRAWN: DW	VISA:
BLA SBS BUS CONTROLLER BLASBS		DATE: 15/05/96	15/05/96
PCB_D: H4P1743D SHE_D: H4S100973		APPROV: BS	VISA:
		DATE: 21/05/96	21/05/96
		DWG: W4S131839	F SHEET: 3/4





ECL Info:
 ECL06 -> ECL07
 C45 and C48 changed from
 Cap SAL 1u to Cap MKS 1u

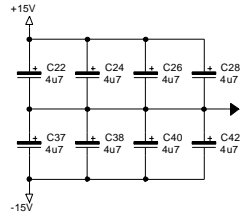


Figure 9.4. BLA DAC Schematic

ART: H5245	EC: 07	DRAWN: DW DATE: 15/05/96	VISA:	
BLA SBS BUS CONTROLLER FORWARD & REFLECTED		APPROV: BS DATE: 21/05/96	VISA:	
PCB_D : H4P1743D SHE_D : H4S100983		DWG: W4S131840	F SHEET: 4/4	

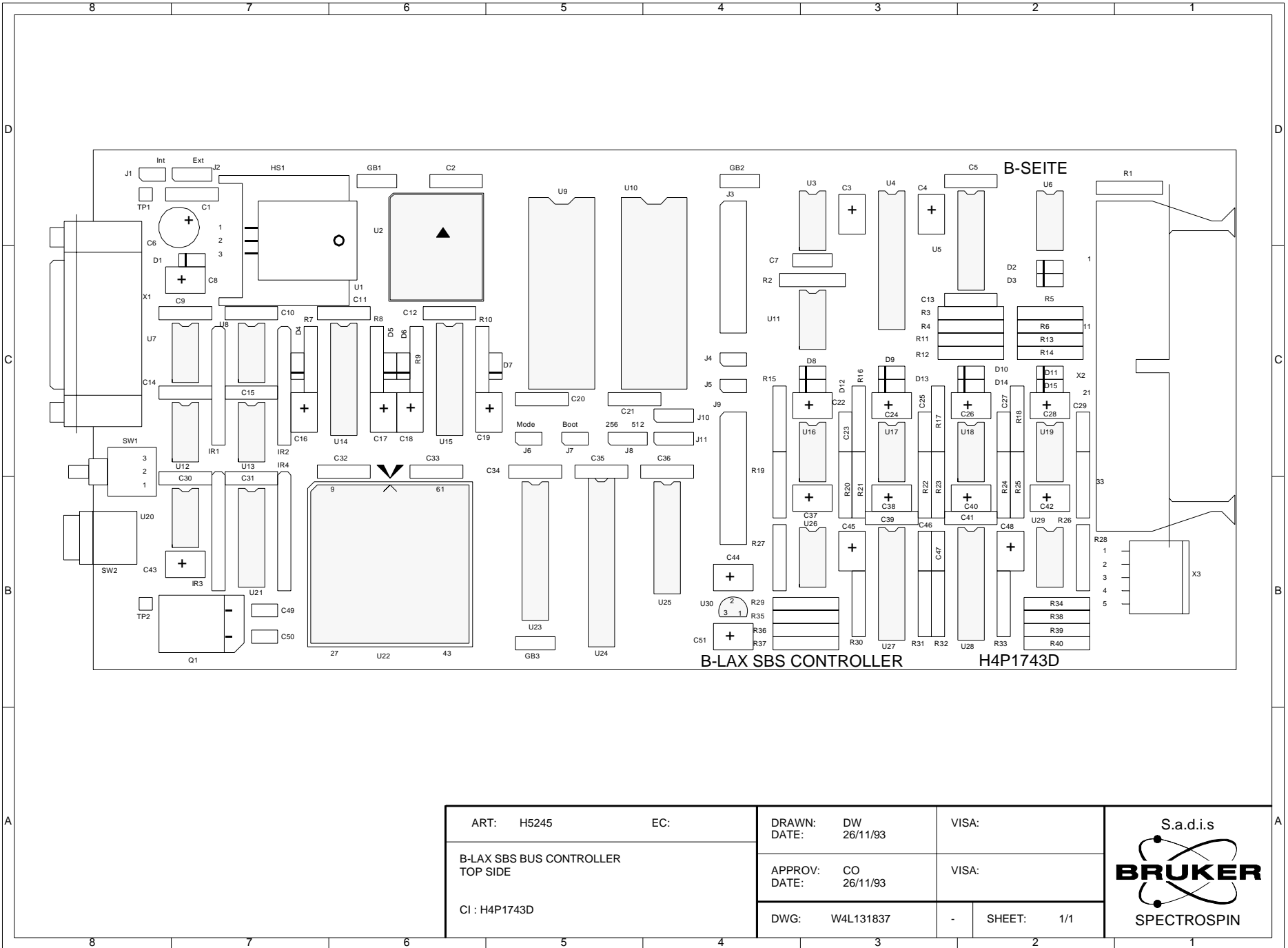
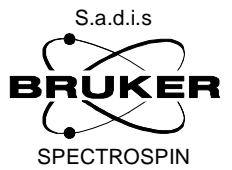


Figure 9.5. B-LAX SBS Bus Controller Location

ART: H5245	EC:	DRAWN: DW	DATE: 26/11/93	VISA:
B-LAX SBS BUS CONTROLLER TOP SIDE		APPROV: CO	DATE: 26/11/93	VISA:
CI : H4P1743D		DWG: W4L131837	-	SHEET: 1/1



BLA SBS Bus Controller

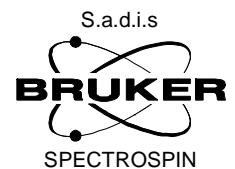
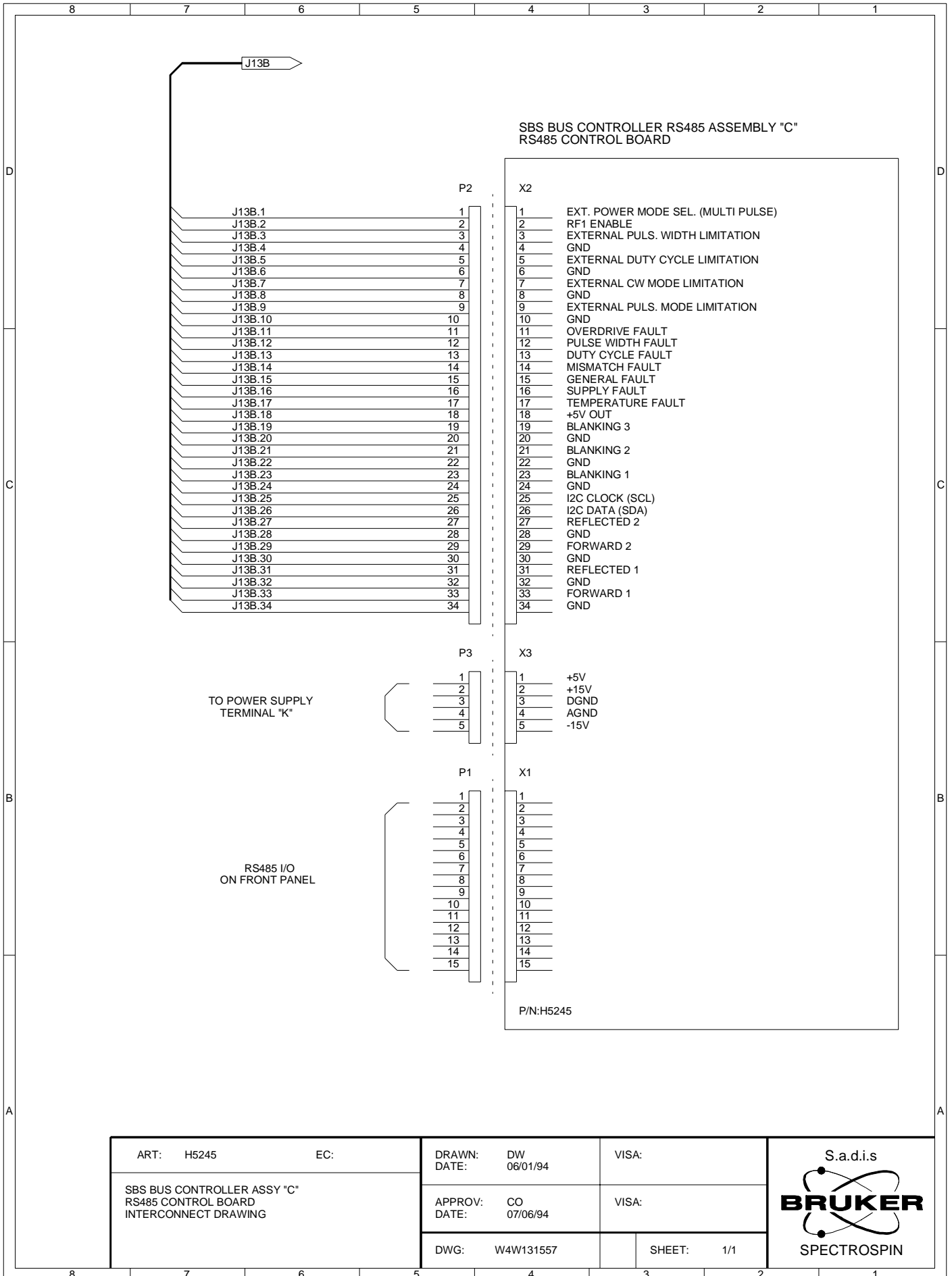
Value Tab Head		Copy In Part:		Draw:
Part:H5245	Drawing:W4S131837F			
Desc:SBS BUS CONTROLLER		ECL:7	Modified:30/10/96	By:MN
Value Tab	Component	Local Description		
Pos.				
D03	6834	DIODE HP5082-2811 SCHOTKY		
D04	2967	DIODE 1N4148		
D05	2967	DIODE 1N4148		
D06	2967	DIODE 1N4148		
D07	2967	DIODE 1N4148		
D08	6834	DIODE HP5082-2811 SCHOTKY		
D09	6834	DIODE HP5082-2811 SCHOTKY		
D10	6834	DIODE HP5082-2811 SCHOTKY		
D11	6834	DIODE HP5082-2811 SCHOTKY		
D12	34640	DIODE Z BZX55C 5.1V 500MW		
D13	34640	DIODE Z BZX55C 5.1V 500MW		
D14	34640	DIODE Z BZX55C 5.1V 500MW		
D15	34640	DIODE Z BZX55C 5.1V 500MW		
GB01	20448	ACCBL CAVALIER 5.08MM D1		
GB02	20448	ACCBL CAVALIER 5.08MM D1		
GB03	20448	ACCBL CAVALIER 5.08MM D1		
ICSU02	51657	IC SUPPORT PLCC32		
ICSU09	2818	IC SUPPORT DIL28 TULIPE		
ICSU10	2818	IC SUPPORT DIL28 TULIPE		
ICSU22	16049	IC SUPPORT PLCC68		
ICSU24	10726	IC SUPPORT DIL24 LARG=7.62		
IR01	16272	RES RES 390X8 2% SIL9		
IR02	16272	RES RES 390X8 2% SIL9		
IR03	10449	RES RES 3.3KX8 2% SIL9		
IR04	10449	RES RES 3.3KX8 2% SIL9		
J01	5778	CN M 50 D PRT MODU2		
J02	5778	CN M 50 D PRT MODU2		
J02'	3033	ACCBL CAVALIER F 2.54MM		
J03	W1303054	CN F 50 PRT MODIFIE		
J04	5778	CN M 50 D PRT MODU2		
J04'	3033	ACCBL CAVALIER F 2.54MM		
J05	5778	CN M 50 D PRT MODU2		
J05'	3033	ACCBL CAVALIER F 2.54MM		
J06	5778	CN M 50 D PRT MODU2		
J07	5778	CN M 50 D PRT MODU2		
J08	5778	CN M 50 D PRT MODU2		
J08'	3033	ACCBL CAVALIER F 2.54MM		
J09	W1303054	CN F 50 PRT MODIFIE		
J10	5778	CN M 50 D PRT MODU2		
J10'	3033	ACCBL CAVALIER F 2.54MM		
J11	5778	CN M 50 D PRT MODU2		
J11'	3033	ACCBL CAVALIER F 2.54MM		
Q01	11691	QUARTZ 12MHZ 12.00-30 TQE 2885		
R01	4446	RES MET 0 1% 0.6W		
R02	1010	RES MET 1K 1% 0.6W 50PPM		
R03	1022	RES MET 10K 1% 0.6W 50PPM		
R04	1022	RES MET 10K 1% 0.6W 50PPM		
R05	1022	RES MET 10K 1% 0.6W 50PPM		
R06	1022	RES MET 10K 1% 0.6W 50PPM		
R07	1036	RES MET 150K 1% 0.6W 50PPM		
R08	1036	RES MET 150K 1% 0.6W 50PPM		
R09	1038	RES MET 221K 1% 0.6W 50PPM		
R10	1036	RES MET 150K 1% 0.6W 50PPM		
R11	1022	RES MET 10K 1% 0.6W 50PPM		
R12	1022	RES MET 10K 1% 0.6W 50PPM		
R13	1022	RES MET 10K 1% 0.6W 50PPM		

+-- Value Tab Head -----+			
Part:H5245		Drawing:W4S131837F	
Desc:SBS BUS CONTROLLER		ECL:7	
+-- Value Tab		Copy In Part: Draw:	
		Modified:30/10/96 By:MN	
Pos.	Component	Local Description	
R14	1001	RES MET 182 1% 0.6W 50PPM	
R15	1022	RES MET 10K 1% 0.6W 50PPM	
R16	1022	RES MET 10K 1% 0.6W 50PPM	
R17	1022	RES MET 10K 1% 0.6W 50PPM	
R18	1022	RES MET 10K 1% 0.6W 50PPM	
R19	1022	RES MET 10K 1% 0.6W 50PPM	
R20	1022	RES MET 10K 1% 0.6W 50PPM	
R21	1001	RES MET 182 1% 0.6W 50PPM	
R22	1001	RES MET 182 1% 0.6W 50PPM	
R23	1022	RES MET 10K 1% 0.6W 50PPM	
R24	1001	RES MET 182 1% 0.6W 50PPM	
R25	1022	RES MET 10K 1% 0.6W 50PPM	
R26	1001	RES MET 182 1% 0.6W 50PPM	
R27	1010	RES MET 1K 1% 0.6W 50PPM	
R28	1010	RES MET 1K 1% 0.6W 50PPM	
R29	1037	RES MET 182K 1% 0.6W 50PPM	
R30	1034	RES MET 100K 1% 0.6W 50PPM	
R31	1022	RES MET 10K 1% 0.6W 50PPM	
R32	1022	RES MET 10K 1% 0.6W 50PPM	
R33	1034	RES MET 100K 1% 0.6W 50PPM	
R34	1037	RES MET 182K 1% 0.6W 50PPM	
R35	1015	RES MET 2.74K 1% 0.6W 50PPM	
R36	1030	RES MET 47.5K 1% 0.6W 50PPM	
R37	1010	RES MET 1K 1% 0.6W 50PPM	
R38	1015	RES MET 2.74K 1% 0.6W 50PPM	
R39	1030	RES MET 47.5K 1% 0.6W 50PPM	
R40	1010	RES MET 1K 1% 0.6W 50PPM	
RAD01	8270	RADIAT KL105 NR 20MM TO-220	
SW01	19544	SW CODE HEX PRT C PANNEAU FR.	
SW02	16065	SW PCI 1XI PRT RESET	
TP01	2083	ACCBL PICOT RND D=1MM	
U01	446	IC 7805/VREG MC7805CT TO220	
U02	22490	IC 28256/N28F256A-200 PLCC32	
U03	7276	IC 02/VREF REF02HP 5V PDIP	
U04	30546	IC 7226/DAC AD7226KN PDIP	
U05	9737	IC 084/OP TL084CN BIFET PDIP14	
U06	6586	IC 072/OP TL072CP PDIP	
U07	18467	IC 75176/DRV SN75176BP PDIP 8	
U08	5941	IC HCPL 2630	
U09	18721	IC 62256/SRAM HM62256LP-10	
U10	H5248	IC 27256 /PROM27256 BLA930608	
U11	42069	IC 24022/E2PR X24022P DIL8	
U12	18467	IC 75176/DRV SN75176BP PDIP 8	
U13	5941	IC HCPL 2630	
U14	134	IC 74123/SN74LS123N PDIP 16	
U15	134	IC 74123/SN74LS123N PDIP 16	
U16	1965	IC 398/SH LF398N PDIP 8	
U17	1965	IC 398/SH LF398N PDIP 8	
U18	1965	IC 398/SH LF398N PDIP 8	
U19	1965	IC 398/SH LF398N PDIP 8	
U20	20094	IC 7705 / TL7705ACP DIL8	
U21	9294	IC 7407/SN74LS07	
U22	18423	IC 80515/MCU SAB80C515A-N18	
U23	14038	IC 74573/SN74ALS573 PDIP	
U24	H5247	IC PAL 22V10-25 BLA0AA00KE	
U25	139	IC 74138/SN74LS138N PDIP 16	

BLA SBS Bus Controller

Value Tab Head			
Part:H5245	Drawing:W4S131837F	Copy In Part:	Draw:
Desc:SBS BUS CONTROLLER	ECL:7	Modified:30/10/96	By:MN
Value Tab			
Pos.	Component	Local Description	
U26	289	IC 311/OP COMP LM311 PDIP8	
U27	9821	IC 74221/SN74LS221N PDIP	
U28	9821	IC 74221/SN74LS221N PDIP	
U29	289	IC 311/OP COMP LM311 PDIP8	
U30	12703	IC 7812/VREG MC78L12ACP TO92	
X01	52267	CN M 15 C PRT SUB-D HARPON	
X02	553	CN M 34 C PRT TRANSI.VER.LONG	
X03	3861	CN M 5 C PRT MODU2	

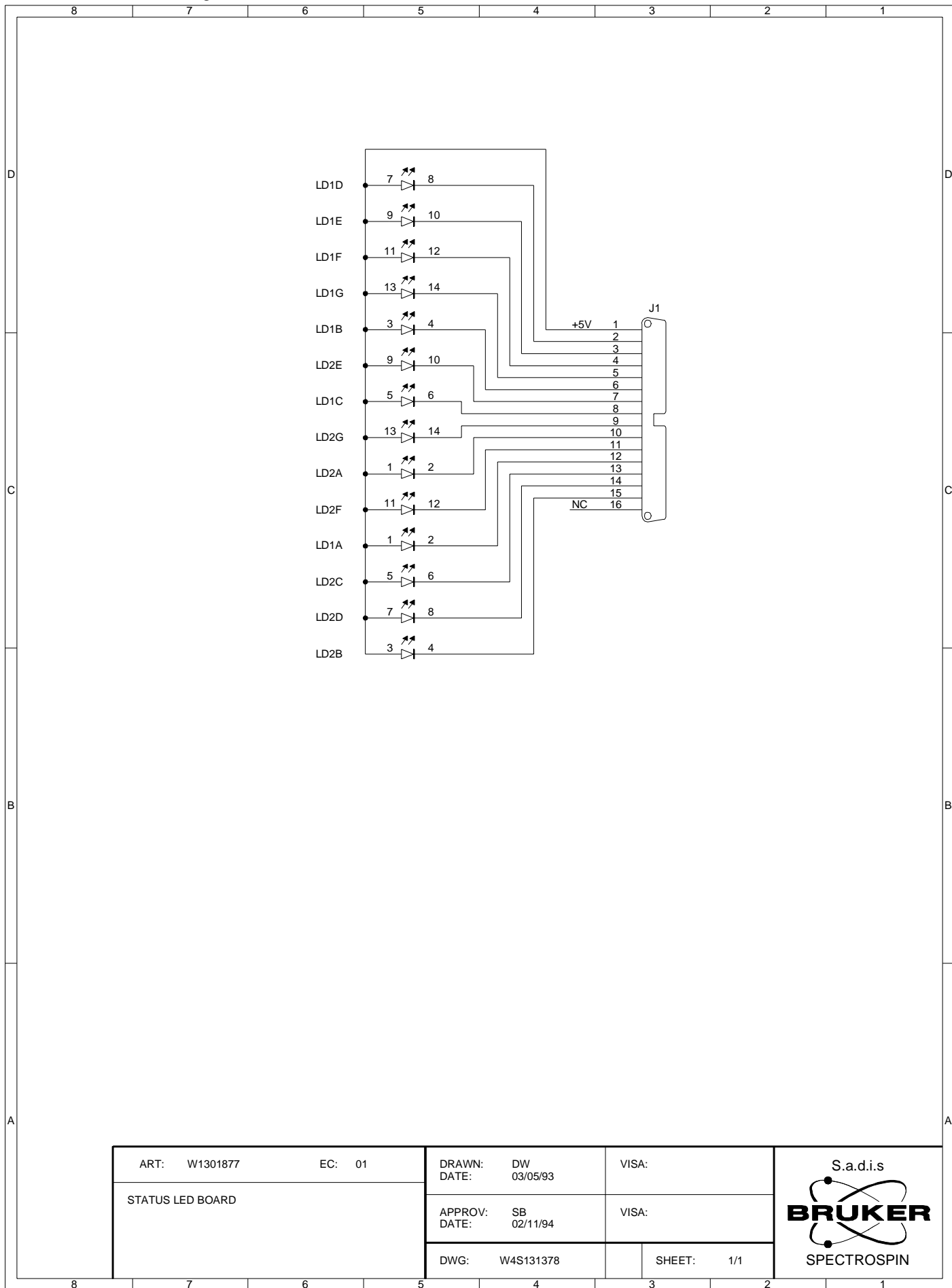
Figure 9.6. Interconnect Drawing ASSY «C» Wiring Diagram



Status Led Board

10

Figure 10.1. Status Led Board Schematic



ART: W1301877	EC: 01	DRAWN: DW	DATE: 03/05/93	VISA:
STATUS LED BOARD		APPROV: SB	DATE: 02/11/94	VISA:
		DWG: W4S131378	SHEET: 1/1	

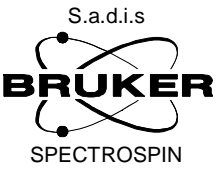
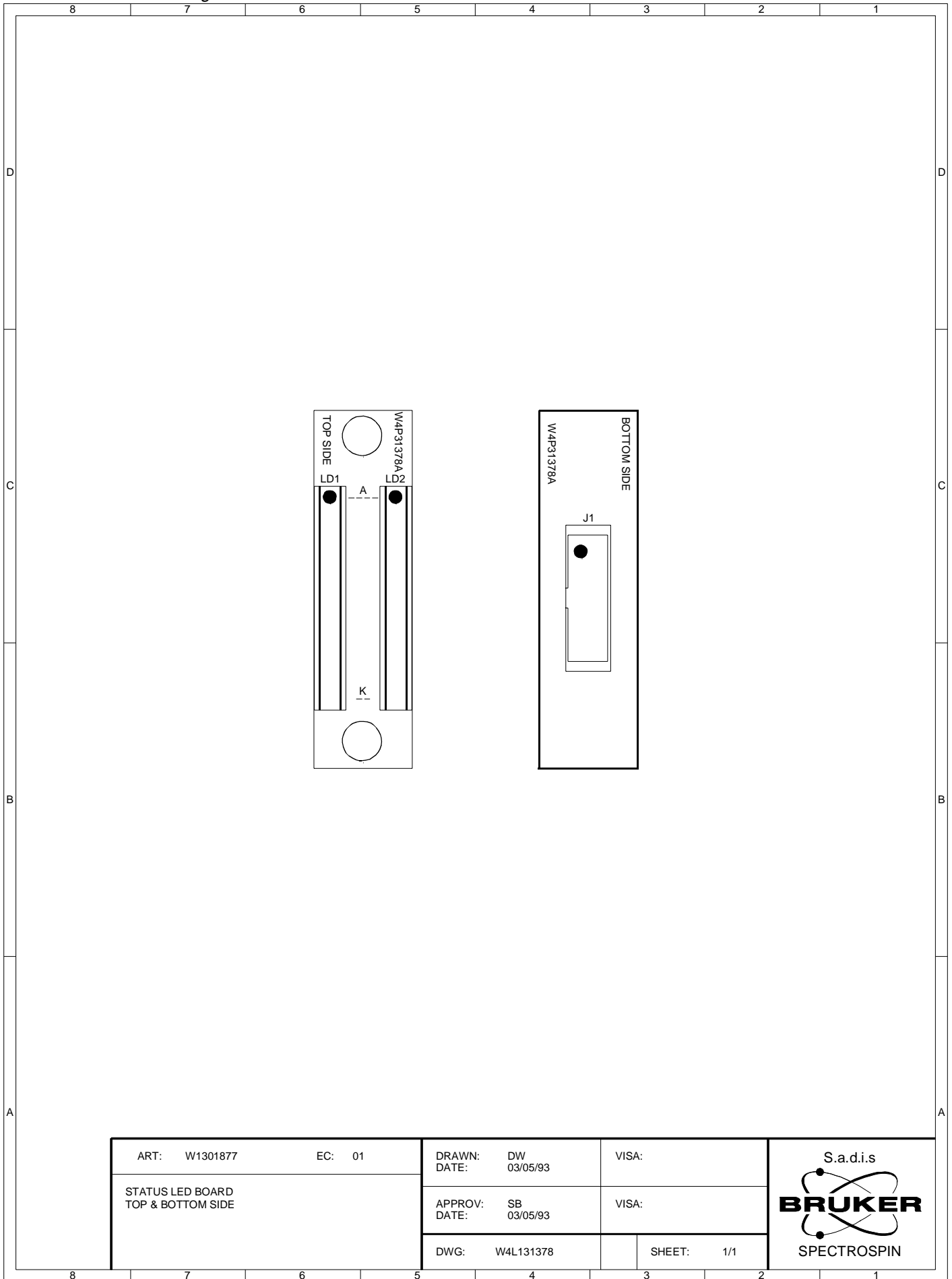


Figure 10.2. Status Led Board Location



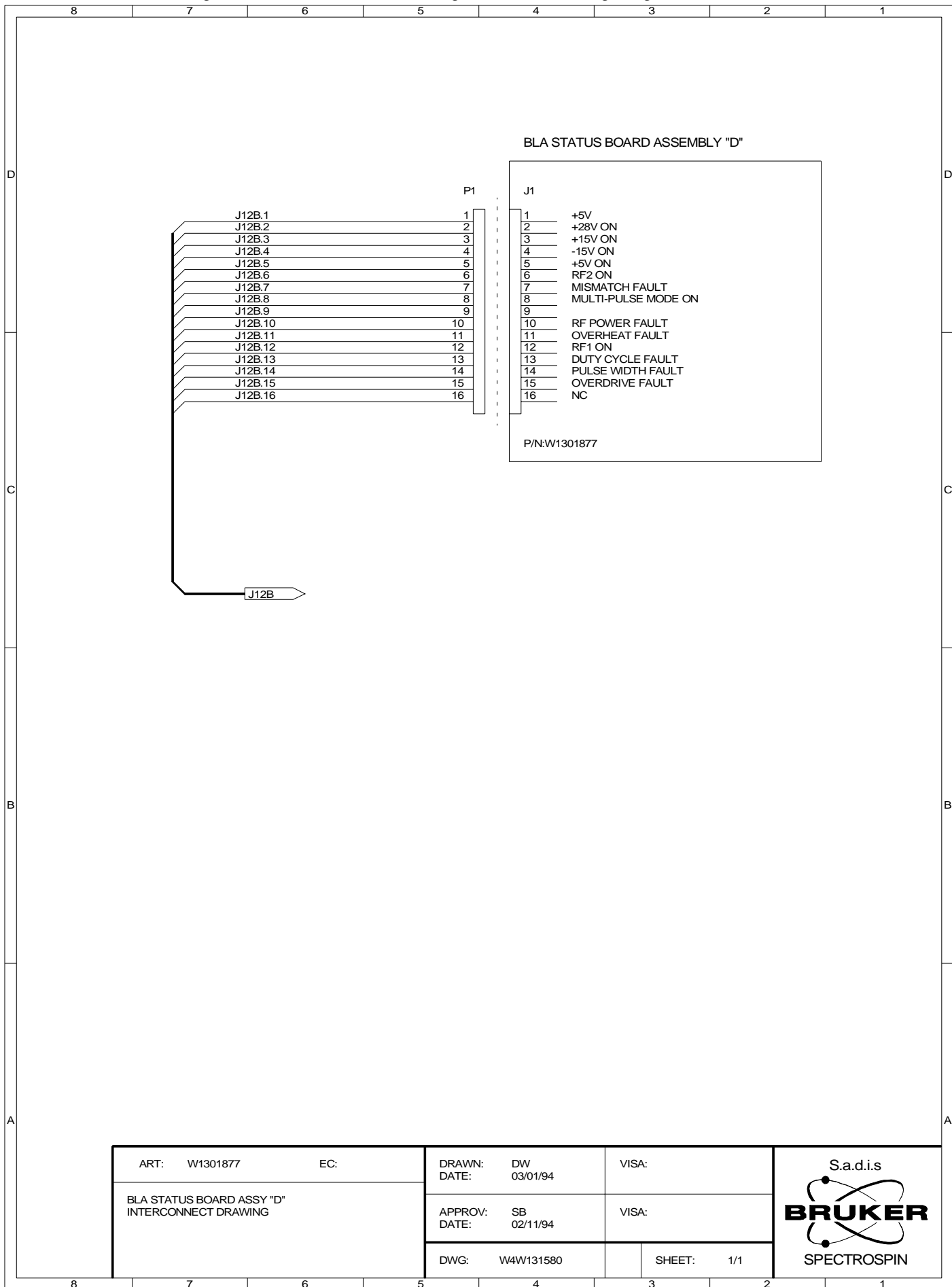
ART: W1301877	EC: 01	DRAWN: DW	VISA:	
STATUS LED BOARD TOP & BOTTOM SIDE		DATE: 03/05/93		
		APPROV: SB	VISA:	
		DATE: 03/05/93		
		DWG: W4L131378	SHEET: 1/1	

Status Led Board

Value Table

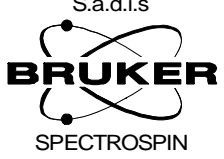
```
+-- Value Tab Head -----+
| Part:W1301877 Drawing:W4S131378          Copy In Part:      Draw:      |
| Desc:STATUS LED BOARD                    ECL:1             Modified:16/01/96  By:DW      |
+-- Value Tab -----+
|      Pos.          Component          Local Description          |
|      CI01          W1356503          CI B-LA STATUS LED          |
|      J01           5613              CN M 16 D PRT TRANSI.REDUI 3.2 |
|      LD01          73424             OPTO LED BAR GRAPH 7X4.8MM VR |
|      LD02          73425             OPTO LED BAR GRAPH 7X4.8MM RG |
+-----+
```


Figure 10.3. Interconnect Drawing ASSY «D» Wiring Diagram



ART: W1301877	EC:	DRAWN: DW	DATE: 03/01/94	VISA:
BLA STATUS BOARD ASSY "D" INTERCONNECT DRAWING		APPROV: SB	DATE: 02/11/94	VISA:
		DWG: W4W131580		SHEET: 1/1

S.a.d.i.s



BRUKER
SPECTROSPIN

Fan Status Board

11

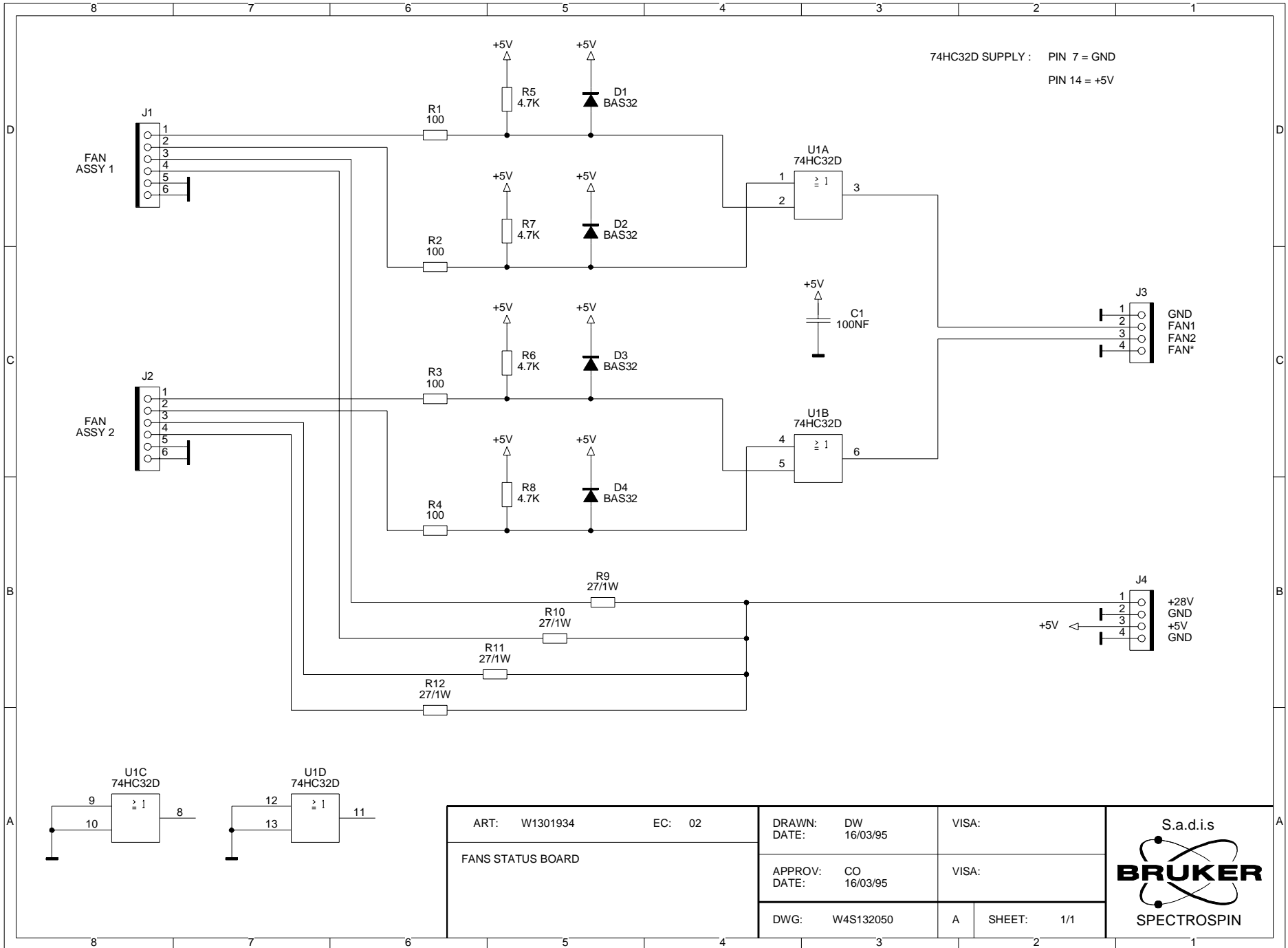
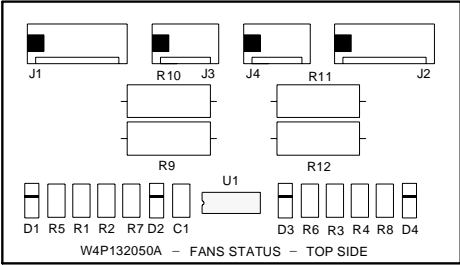


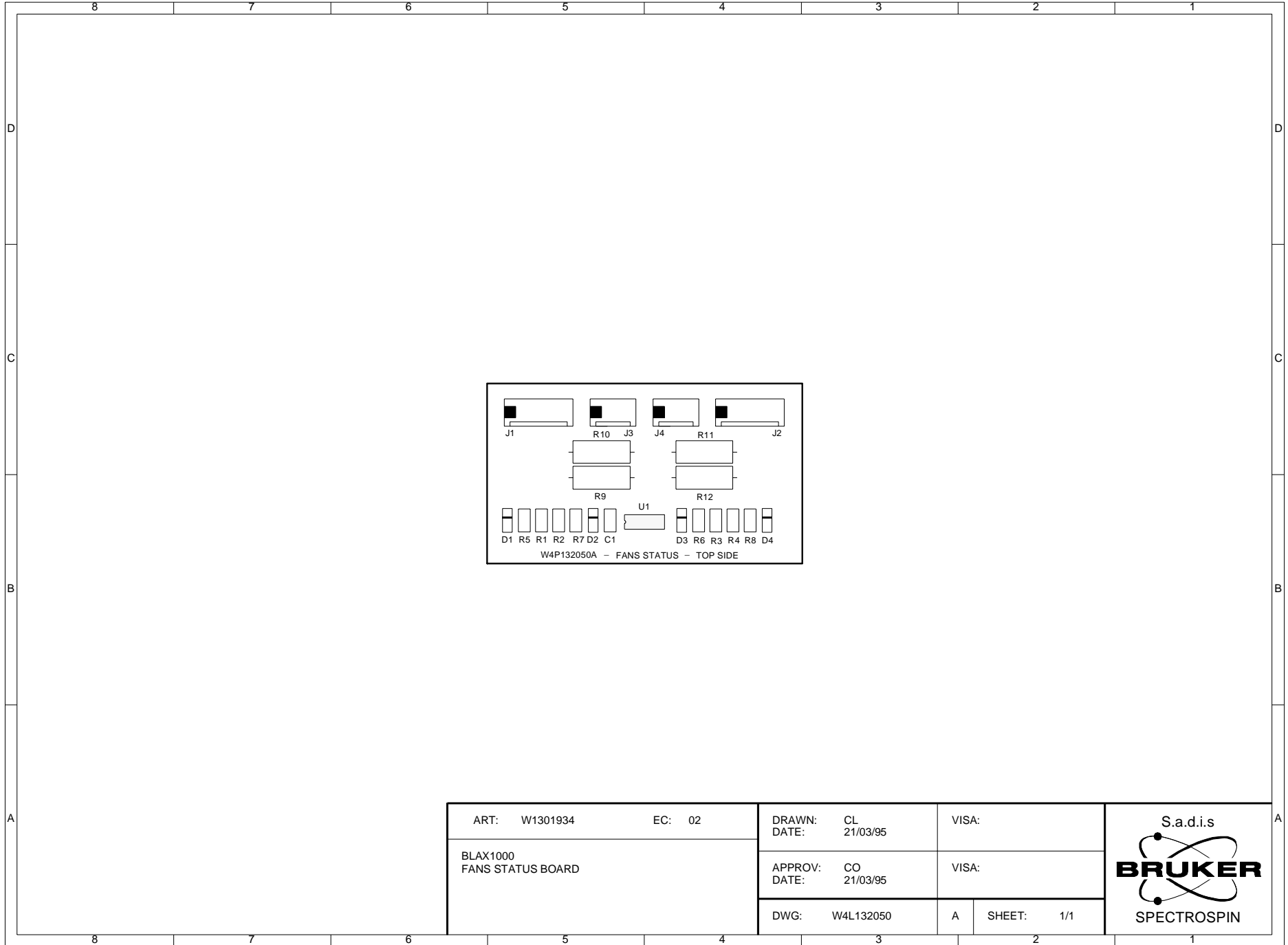
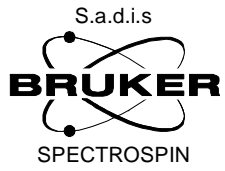
Figure 11.1. Fan Status Board Schematic

ART: W1301934	EC: 02	DRAWN: DW	VISA:	
FANS STATUS BOARD		DATE: 16/03/95	DATE: 16/03/95	
DWG: W4S132050	A	SHEET: 1/1		

Figure 11.2. Fan Status Board Location



ART: W1301934	EC: 02	DRAWN: CL	VISA:
BLAX1000 FANS STATUS BOARD		DATE: 21/03/95	
		APPROV: CO	VISA:
		DATE: 21/03/95	
DWG: W4L132050	A	SHEET: 1/1	



Fan Status Board

Value Table

Value Tab Head			
Part:W1301934	Drawing:W4S132050	Copy In Part:	Draw:
Desc:CIRCUIT STATUS VENTILATEURS	ECL:1	Modified:16/01/96	By:DW
Value Tab			
Pos.	Component	Local Description	
A01	35779	ACCBL LANGUETTE PL 2.8 PRT	
A02	35779	ACCBL LANGUETTE PL 2.8 PRT	
A03	35779	ACCBL LANGUETTE PL 2.8 PRT	
A04	35779	ACCBL LANGUETTE PL 2.8 PRT	
A05	35779	ACCBL LANGUETTE PL 2.8 PRT	
A06	35779	ACCBL LANGUETTE PL 2.8 PRT	
A07	35779	ACCBL LANGUETTE PL 2.8 PRT	
C01	8493	COND CMS 1206 100N 50V 20% X7R	
CI01	W1356584	CI CIRCUIT STATUS VENTILATEURS	
D01	22029	DIODE CMS BAS32L SOD80	
D02	22029	DIODE CMS BAS32L SOD80	
D03	22029	DIODE CMS BAS32L SOD80	
D04	22029	DIODE CMS BAS32L SOD80	
J01	35464	CN M 6 D PRT 6410	
R01	20724	RES CMS 100 1% 0.25W 1206	
R02	20724	RES CMS 100 1% 0.25W 1206	
R03	20724	RES CMS 100 1% 0.25W 1206	
R04	20724	RES CMS 100 1% 0.25W 1206	
R05	20745	RES CMS 4.7K 1% 0.25W 1206	
R06	20745	RES CMS 4.7K 1% 0.25W 1206	
R07	20745	RES CMS 4.7K 1% 0.25W 1206	
R08	20745	RES CMS 4.7K 1% 0.25W 1206	
ST01	1235	CN COAX SMB M D PRT	
U01	51782	IC 7432/SN74HC32D SO14 CMS	

Supply Status Driver

12

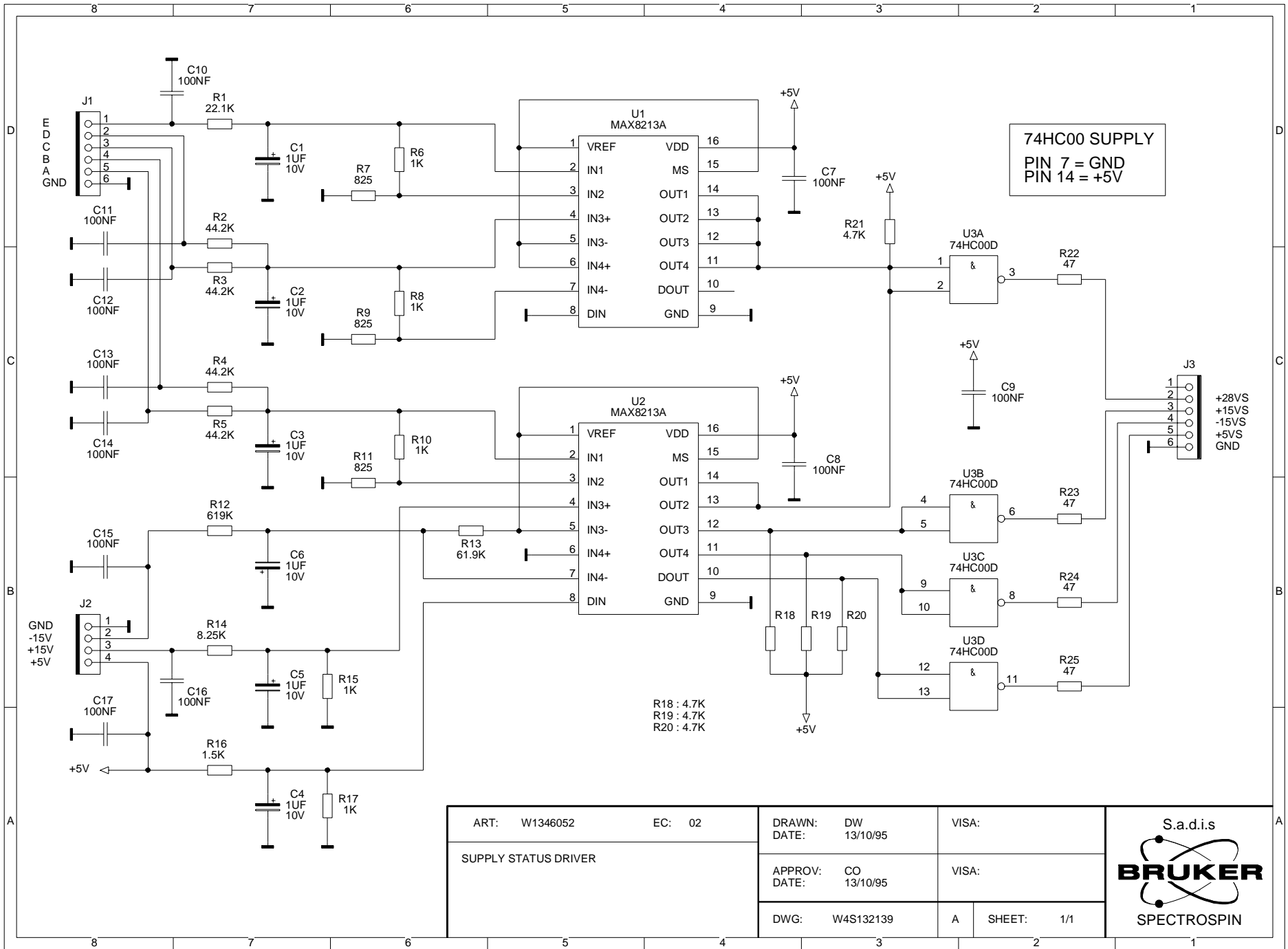


Figure 12.1. Supply Status Driver Schematic

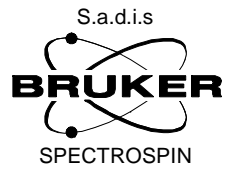
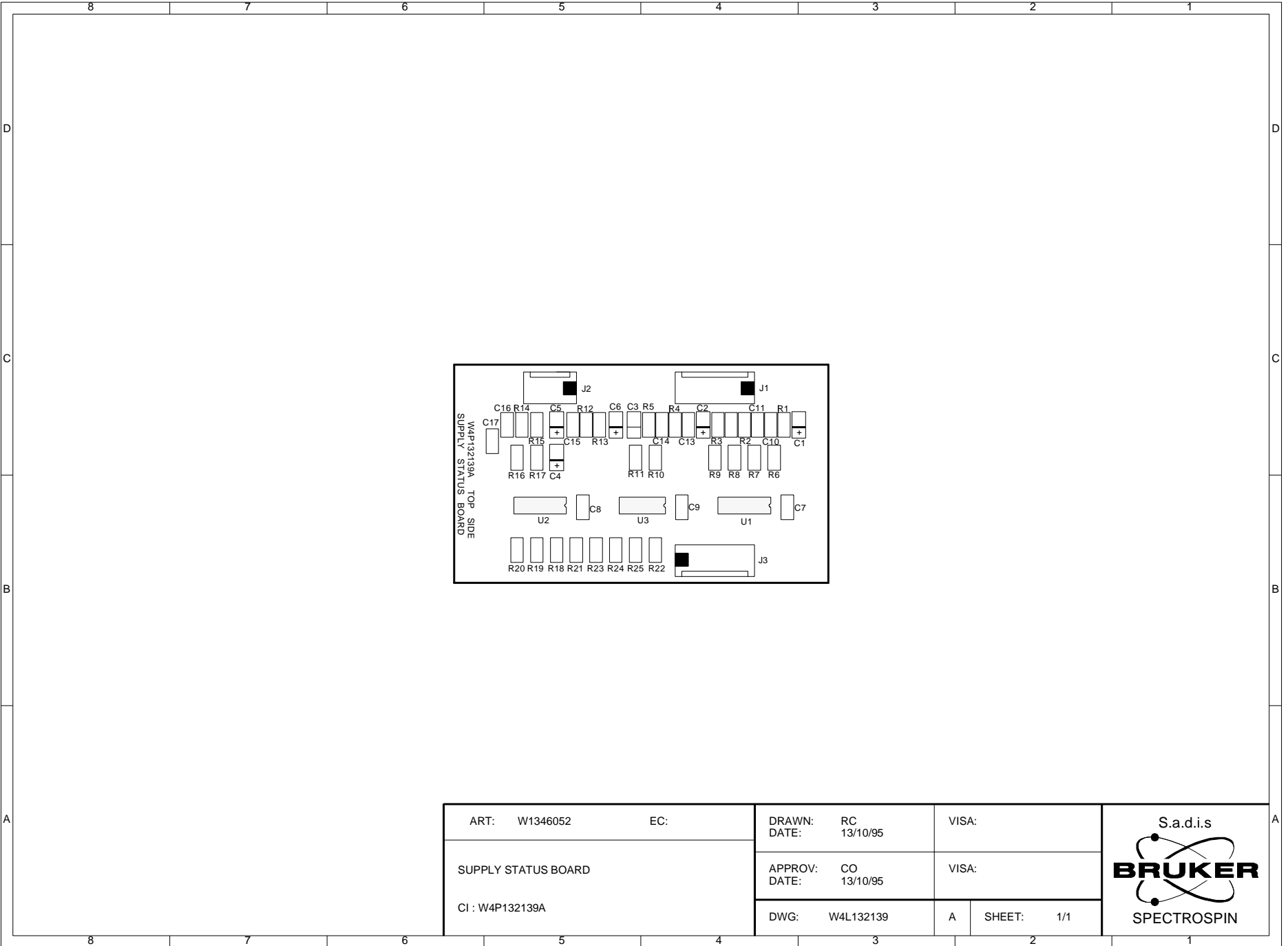
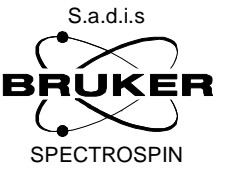


Figure 12.2: Supply Status Driver Location



ART: W1346052	EC:	DRAWN: RC	VISA:
SUPPLY STATUS BOARD		DATE: 13/10/95	
		APPROV: CO	VISA:
CI : W4P132139A		DATE: 13/10/95	
		DWG: W4L132139	A SHEET: 1/1



Supply Status Driver

Value Table

Value Tab Head			
Part:W1346052	Drawing:W4S132139A	Copy In Part:	Draw:
Desc:CIRCUIT STATUS ALIMENTATION	ECL:2	Modified:10/01/96	By:CO
Value Tab			
Pos.	Component	Local Description	
C01	72171	COND CMS TANTAL 1U 10V 20%	
C02	72171	COND CMS TANTAL 1U 10V 20%	
C03	72171	COND CMS TANTAL 1U 10V 20%	
C04	72171	COND CMS TANTAL 1U 10V 20%	
C05	72171	COND CMS TANTAL 1U 10V 20%	
C06	72171	COND CMS TANTAL 1U 10V 20%	
C07	8493	COND CMS 1206 100N 50V 20% X7R	
C08	8493	COND CMS 1206 100N 50V 20% X7R	
C09	8493	COND CMS 1206 100N 50V 20% X7R	
C10	8493	COND CMS 1206 100N 50V 20% X7R	
C11	8493	COND CMS 1206 100N 50V 20% X7R	
C12	8493	COND CMS 1206 100N 50V 20% X7R	
C13	8493	COND CMS 1206 100N 50V 20% X7R	
C14	8493	COND CMS 1206 100N 50V 20% X7R	
C15	8493	COND CMS 1206 100N 50V 20% X7R	
C16	8493	COND CMS 1206 100N 50V 20% X7R	
C17	8493	COND CMS 1206 100N 50V 20% X7R	
CI01	W1356664	CI CIRCUIT STATUS ALIMENTATION	
J01	35464	CN M 6 D PRT 6410	
J02	35013	CN M 4 D PRT 6410	
J03	35464	CN M 6 D PRT 6410	
R01	21327	RES CMS 22.1K 1% 0.25W 1206	
R02	51746	RES CMS 44.2K 1% 0.25W 1206	
R03	51746	RES CMS 44.2K 1% 0.25W 1206	
R04	51746	RES CMS 44.2K 1% 0.25W 1206	
R05	51746	RES CMS 44.2K 1% 0.25W 1206	
R06	20737	RES CMS 1K 1% 0.25W 1206	
R07	20735	RES CMS 825 1% 0.25W 1206	
R08	20737	RES CMS 1K 1% 0.25W 1206	
R09	20735	RES CMS 825 1% 0.25W 1206	
R10	20737	RES CMS 1K 1% 0.25W 1206	
R11	20735	RES CMS 825 1% 0.25W 1206	
R12	51758	RES CMS 619K 1% 0.25W 1206	
R13	51757	RES CMS 61.9K 1% 0.25W 1206	
R14	20748	RES CMS 8.25K 1% 0.25W 1206	
R15	20737	RES CMS 1K 1% 0.25W 1206	
R16	20739	RES CMS 1.5K 1% 0.25W 1206	
R17	20737	RES CMS 1K 1% 0.25W 1206	
R18	20745	RES CMS 4.7K 1% 0.25W 1206	
R19	20745	RES CMS 4.7K 1% 0.25W 1206	
R20	20745	RES CMS 4.7K 1% 0.25W 1206	
R21	20745	RES CMS 4.7K 1% 0.25W 1206	
R22	73283	RES CMS 47.5 1% 0.25W 1206	
R23	73283	RES CMS 47.5 1% 0.25W 1206	
R24	73283	RES CMS 47.5 1% 0.25W 1206	
R25	73283	RES CMS 47.5 1% 0.25W 1206	
U01	56531	IC 8213/MAX8213 TRIVOL MO SO16	
U02	56531	IC 8213/MAX8213 TRIVOL MO SO16	
U03	22042	IC 7400/SN74HC00D SO14 CMS	

Power Supply Terminal

13

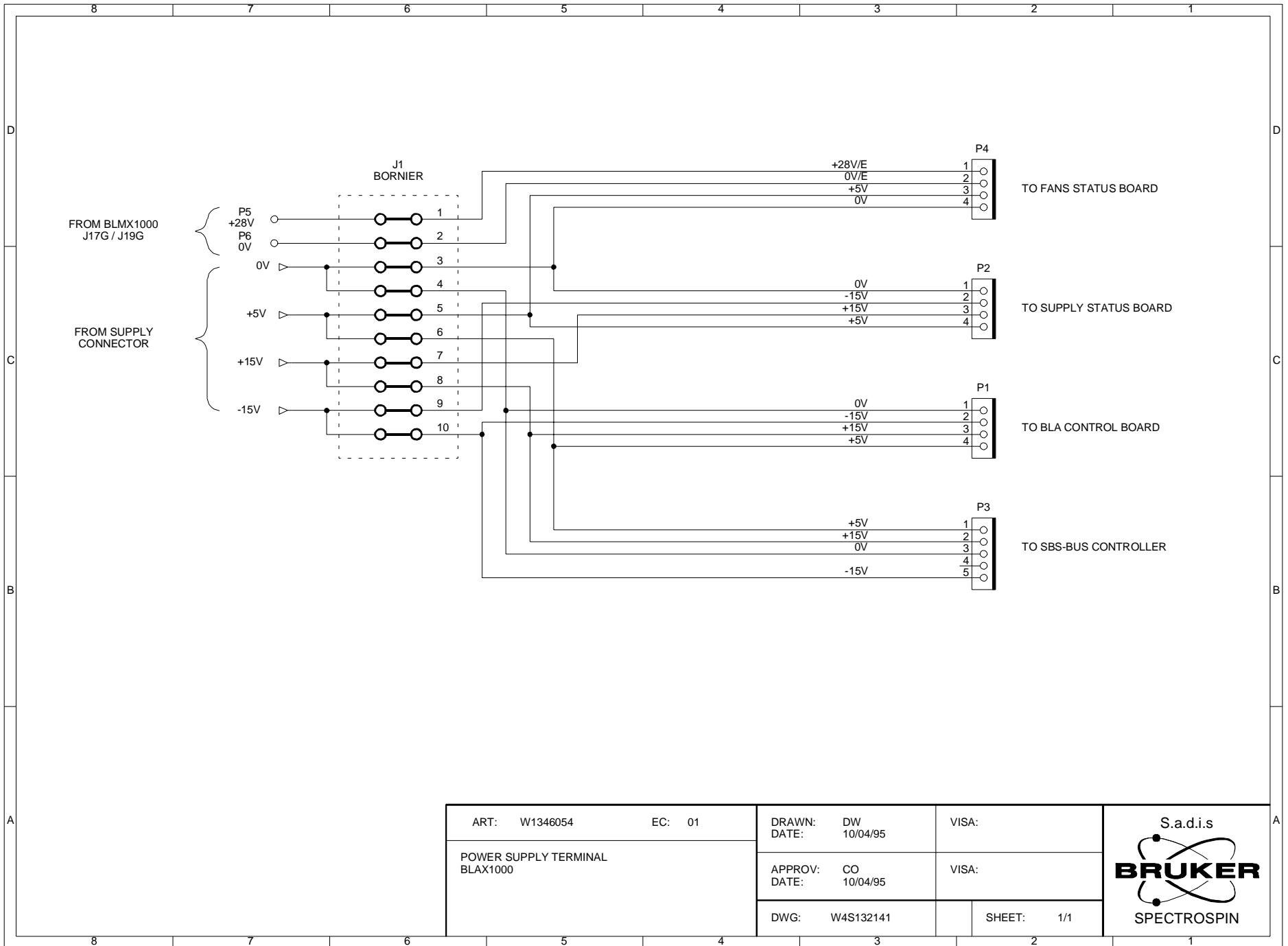
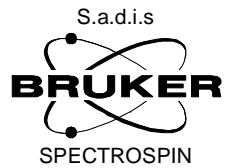


Figure 13.1. Power Supply Terminal Schematic



Value Table

```
+-- Value Tab Head -----+
| Part:W1346054 Drawing:W4S132141          Copy In Part:          Draw:          |
| Desc:BORNIER DE CONNEXION BLAX1000  ECL:1      Modified:16/01/96    By:DW          |
+-- Value Tab -----+
|      Pos.          Component          Local Description          |
|      J01.01        37143              BORNIER AKZ 1.5 PA          |
|      J01.02        37143              BORNIER AKZ 1.5 PA          |
|      J01.03        37143              BORNIER AKZ 1.5 PA          |
|      J01.04        37143              BORNIER AKZ 1.5 PA          |
|      J01.05        37143              BORNIER AKZ 1.5 PA          |
|      J01.06        37143              BORNIER AKZ 1.5 PA          |
|      J01.07        37143              BORNIER AKZ 1.5 PA          |
|      J01.08        37143              BORNIER AKZ 1.5 PA          |
|      J01.09        37143              BORNIER AKZ 1.5 PA          |
|      J01.10        37143              BORNIER AKZ 1.5 PA          |
|      P01           20015              CN F 4 SRT BOI 3069        |
|      P02           35128              CN F 4 SRT BOI 6471        |
|      P03           3862                CN F 5 BOI MODU4           |
|      P04           35128              CN F 4 SRT BOI 6471        |
|      P05           35775              ACCBL CLIP FASTON 6.3 0.5-1.5 |
|      P06           35775              ACCBL CLIP FASTON 6.3 0.5-1.5 |
+-----+
```


Specifications

14

Common Characteristics

14.1

RF Input Connector	SMA (F)
Blanking Pulse Connector	BNC (F)
X1000 Output Connector	N (F)
X1000.X300 Selection Pulse	BNC (F)
X300 Output Connector	N (F)
* Duty Cycle limitation	Disabled by "Multi-pulses Mode" Control

Table 14.1. X1000 and X300 outputs specifications

RF Specifications	X1000 out	X300 out
Frequency range	30 to 325 MHz	30 to 325 MHz
Linear Gain	64 dB ± 1	55 dB ± 1
Gain Flatness	3 dB max.	3 dB max.
Minimum Pulsed Output Power	1000 W to 200 MHz ; 700W to 325 MHz	250 W (full range)
CW Output Power	50 W max. (internal limitation)	15 W
Linear Output Power (±1,5dB from linear)	1000W to 200MHz ; 500W to 325MHz	200 W at 1 dBm compression
Amplifier Biasing	Class AB Operation	Class AB Operation
Blanking Delay	< 1 µs typ. "ON" and "OFF"	< 1 µs typ. "ON" and "OFF"
RF Rise Time	< 200 ns	< 200 ns
RF Fall Time	< 50 ns	< 50 ns
DC Ringing	± 500 mV typ. (due to blanking signal)	± 100 mV typ. (due to blanking signal)
Input Noise Figure	7 dB max.	7 dB max.
Output Noise Power (Unblanked)	- 103 dBm @ 1 Hz	- 112 dBm @ 1 Hz
Output Noise Power (Blanked)	Thermal noise	- 154 dBm @ 1 Hz
IN/OUT Impedance	50 ohms	50 ohms
Input V.S.W.R.	1,3 max.	1,3 max.
Output Harmonics 2nd order	-25 dBc min. full range	20 dBc (70 to 325 MHz) at 250 W
Output Harmonics 3rd order	-13 dBc to 100MHz ; -25dBc above 100MHz	
Pulse Width (int. limitation)	100 ms @ 1000 W (up to CW at 50 W)	100 ms @ 300 W (up to CW at 15 W)
Duty Cycle (int. limitation)*	5 % @ 1000 W (up to 100 % at 50 W)	5 % @ 300 W (up to 100 % at 15 W)
Amplitude Droop	5 % @ 700 W to 10 ms typ ; 8 % max.	5 % @ 250 W to 10 ms typ ; 8 % max.

Table 14.2. General requirements

Dimensions	19" rack cabinet, 4U height, 580 mm depth
Weight	29 Kgs

Table 14.3. General requirements

Power requirements	220V Single phase
Dimensions	19" x 3U x 520
Weight	21,5 Kgs

Figures

1	General description	7
Figure 1.1.	Front panel wiring	8
2	BLAX1000 Amplifier 30-325MHz	9
Figure 2.1.	BLAX1000 Amplifier 30-325MHz Block Diagram	10
3	BLAX1010 Option HR	11
Figure 3.1.	BLAX1010 Block Diagram	12
4	BLMX1000 RF Amplifier Module 30-325MHz	13
Figure 4.1.	BLMX1000 RF Amplifier Module 30-325MHz Block Diagram	14
Figure 4.2.	LABX001 RF Amplifier Board 30-325MHz Block Diagram	15
Figure 4.3.	LABX001 RF Amplifier Board 30-325MHz Schematic	16
Figure 4.4.	LABX300 RF Amplifier Board 30-325MHz / 27dB Block Diagram	19
Figure 4.5.	LABX300 RF Amplifier Board 30-325MHz / 27dB Schematic	20
Figure 4.6.	Non Inverted Blanking Schematic	23
Figure 4.7.	Non Inverted Blanking Location	24
Figure 4.8.	LABX300 RF Amplifier Board 30-325MHz / 7dB Schematic	26
Figure 4.9.	LABX300 RF Amplifier Board 30-325MHz / 7dB Location	27
Figure 4.10.	Splitter / Combiner 4 Ways Block Diagram	30
Figure 4.11.	Splitter / Combiner 4 Ways Schematic	31
Figure 4.12.	Splitter / Combiner 4 Ways Location	32
Figure 4.13.	Push Fan Assembly 1 Schematic	34
Figure 4.14.	Pull Fan Assembly 2 Schematic	36
5	BDCX46 Coupler	39
Figure 5.1.	BDCX46 Coupler Schematic	40
6	BDCX40 Coupler	43
Figure 6.1.	BDCX40 Coupler Schematic	44
7	BLA Control Board 2	47
Figure 7.1.	BLA Control Board 2 Location (Top Side)	48
Figure 7.2.	BLA Control Board 2 Location (Bottom Side)	49
Figure 7.3.	Power Supply & Reference Schematic	50
Figure 7.4.	Thermal Sense, Supply & Fan Control Schematic	51
Figure 7.5.	Forward & Reflected Schematic	52
Figure 7.6.	Duty Cycle & Pulse width Limiter Schematic	53
Figure 7.7.	Power Limitation Schematic	54
Figure 7.8.	Blanking Circuit Schematic	55

Figure 7.9. Interconnection & Pal Schematic	56
Figure 7.10. Pal BLA02/01 Hardware Schematic	57
Figure 7.11. Interconnect Drawing ASSY «B» Wiring Diagram	65
Figure 7.12. Interconnect Drawing ASSY «B» Wiring Diagram	66
8 BLA Control Board Extension	67
Figure 8.1. Control Board Extension Schematic	68
Figure 8.2. Control Board Extension Location	69
Figure 8.3. Pal CBE01/01 Hardware Schematic	70
9 BLA SBS Bus Controller	73
Figure 9.1. BLA CPU Schematic	74
Figure 9.2. BLA DAC Schematic	75
Figure 9.3. BLA SBS Schematic	76
Figure 9.4. BLA DAC Schematic	77
Figure 9.5. BLA SBS Bus Controller Location	78
Figure 9.6. Interconnect Drawing ASSY «C» Wiring Diagram	83
10 Status Led Board	85
Figure 10.1. Status Led Board Schematic	86
Figure 10.2. Status Led Board Location	87
Figure 10.3. Interconnect Drawing ASSY «D» Wiring Diagram	89
11 Fan Status Board	91
Figure 11.1. Fan Status Board Schematic	92
Figure 11.2. Fan Status Board Location	93
12 Supply Status Driver	95
Figure 12.1. Supply Status Driver Schematic	96
Figure 12.2. Supply Status Driver Location	97
13 Power Supply Terminal	99
Figure 13.1. Power Supply Terminal Schematic	100
14 Specifications	103

Tables

1	General description	7
2	BLAX1000 Amplifier 30-325MHz	9
3	BLAX1010 Option HR	11
4	BLMX1000 RF Amplifier Module 30-325MHz	13
5	BDCX46 Coupler	39
6	BDCX40 Coupler	43
7	BLA Control Board 2	47
8	BLA Control Board Extension	67
9	BLA SBS Bus Controller	73
10	Status Led Board	85
11	Fan Status Board	91
12	Supply Status Driver	95
13	Power Supply Terminal	99
14	Specifications	103
Table 14.1.	X1000 and X300 outputs specifications	104
Table 14.2.	General requirements	104
Table 14.3.	General requirements	105

