

PTS DL620 Frequency Synthesizer

PTS Frequency Synthesizer Operation Manual

Version 002

BRUKER

The information in this book has been carefully checked by Programmed Test Sources, Inc., and is believed to be accurate; however, no responsibility is assumed for errors or omissions.

All information contained in this document is the property of Programmed Test Sources, Inc. The providing of this document to any person or organization external to Programmed Test Sources, Inc. shall in no way be construed as a license or as permission to use this information for any purpose other than to facilitate the use and maintenance of Programmed Test Sources equipment.

This manual was written by

Programmed Test Sources Inc.

© 1996 by Programmed Test Sources Inc.

Littleton, Massachusetts, U.S.A

The information in this manual may be altered without notice.

BRUKER accepts no responsibility for actions taken as a result of use of this manual. BRUKER accepts no liability for any mistakes contained in the manual, leading to coincidental damage, whether during installation or operation of the instrument. Unauthorized reproduction of manual contents, without written permission from the publishers, or translation into another language, either in full or in part, is forbidden.

This manual was desktop published by

Stanley J. Niles

© February 4, 1997: Bruker Elektronik GmbH

Rheinstetten, Germany

P/N: Z31374

DWG-Nr: 1083002

Contents

	Contents	iii
1	Introduction	5
1.1	General	5
	Manual Organization	5
2	Specifications	7
2.1	Note	7
2.2	Frequency	7
2.3	Switching Time (to within 0.1 radian at new frequency)	7
2.4	Output	8
2.5	Spurious Outputs	8
2.6	Frequency Standard	8
2.7	General	9
3	Installation	11
3.1	Caution	11
3.2	Safety Declarations	11
3.3	Unpacking	11
3.4	Dimensions and Weight	12
3.5	Primary Power	12
3.6	Bench Use	13
3.7	Rack Mounting	13
4	Performance/Incoming Inspection Testing	15
4.1	General	15
	Frequency Verification	15
	Output Level Verification	16
	Harmonic, Subharmonic and Spurious Output Verification .	
	16	
	Frequency Standard Verification	17
5	Operation	19
5.1	Power Connection	19
5.2	Warm-Up	19
5.3	Internal-External Frequency Standard	19
5.4	Rear Panel Controls and Connectors	19
5.5	Remote Frequency Programming	21
6	Principle of Operation	23
6.1	General	23

6.2	Standard Frequency Section	25
6.3	Remote-Control Interface Section	25
6.4	1 MHz Step Section	25
6.5	10 MHz Step Section	26
6.6	Doubler, Output Amplifier and Level Control	26
6.7	Auxiliary Frequency-Generating Modules	27
7	Service	29
7.1	Caution	29
7.2	General	29
7.3	System Troubleshooting	29
8	Calibration	33
8.1	General	33
8.2	SO-1052 Module Calibration	33
8.3	10 MHz Internal Frequency Standard Calibration	34
9	Mainframe Components	35
9.1	Power Supply PS-1053	35
9.2	Crystal Oscillator OCXO (XT-1012)	35
9.3	Opto-Coupled Parallel Entry Boards OPE-2013	36
9.4	505 MHz Filter 390-1003	36
9.5	Multi-10 MHz Board MT-2015	36
10	Schematics	37
	Figures	47
	Tables	49

Introduction

1

General

1.1

This manual covers the PTS DL620 Frequency Synthesizer and contains information necessary to install, operate and service the instrument.

The PTS DL620 is a precision frequency generator. It uses the accuracy and stability of a frequency standard operating at 5.0 or 10.0 MHz, either built-in or external, to provide two independently programmable output channels capable of producing frequencies between 3.0 and 619.999 999 9 MHz. For each independent channel, the instrument requires the injection of a „fine resolution“ signal between 3 and 4 MHz which carries any 100 KHz and finer frequency resolution increment. With these fine-resolution inputs, each independent channel may be programmed by remote control to produce any frequency within the above band with resolution as fine as 1 MHz. Each programmable output from the levelled system is +4 dBm (nominally) into 50 ohms and may be adjusted by an internally located potentiometer. In addition, the instrument provides as output a number of fixed auxiliary frequencies. All output frequencies produced by the PTS DL620 are coherent with the standard frequency and reflect its stability and accuracy.

The PTS DL620 is a direct frequency synthesizer capable of providing signals for many uses requiring stable and accurate sine wave signals with low attendant spurious outputs, low phase noise and fast transfer between selected frequencies. Typical applications include communications, spectrum analysis, surveillance and radar, and automatic test systems with both narrow and wideband coverage.

Manual Organization

1.1.1

The PTS DL620 is a complete and integrated system using numerous modules installed on a deck inside the instrument mainframe. All information pertaining to the instrument as a complete system is presented in this Operation Manual. This manual also covers items which are integral parts of the mainframe, such as power supply, rear panel and crystal oscillator.

Specifications

2

Note

2.1

NOTE: Specifications apply to both independently programmable output channels F1 and F2, and require that the injected fine-resolution input for each channel have equal or better specifications.

Frequency

2.2

Range:	3.000 000 0 to 619.999 999 9 MHz (3 - 300 MHz direct, 300 - 620 MHz with DOUBLE command)
Resolution:	1 MHz (finer resolution dependent on fine resolution input)
Control:	Frequency: remote by opto-coupled parallel entry BCD-encoded negative true logic DOUBLE: remote by opto-coupled positive true logic
Fine-Resolution Input:	3.000 000 0 to 4.000 000 0 MHz, 0 dBm

Switching Time (to within 0.1 radian at new frequency)

2.3

100 MHz - 10 MHz digits:	20 μ seconds
1 MHz digit:	5 μ seconds

Specifications

Output

2.4

Level:	+4 dBm, adjustable by internal potentiometer +/- 1 dB
Flatness:	+/- 0.7 dB
Impedance:	50 Ω
Control:	manual by internal potentiometer

Spurious Outputs

2.5

Discrete:	-60 dBc (-55 dBc, 1/2 f _{out} 300 - 620 MHz; -45 dBc, 3/2 f _{out} 300 - 310 MHz; -55 dBc, 3/2 f _{out} 310 - 620 MHz)
AC line-related 50/60 Hz:	-85 dBc
Fan-related 220/1800 Hz:	-90 dBc
Harmonics:	-30 dBc
Phase Noise:	-63 dBc (0.5 Hz to 15 KHz, including effects of internal standard)
£ (1 Hz):	100 Hz / -100 dBc, 1 KHz / -110 dBc, 10 KHz / -120 dBc, 100 KHz / -125 dBc
Noise Floor:	-130 dBc/Hz

Frequency Standard

2.6

(Note: internal or external standard required for operation)

Internal OCXO:	3×10^{-9} / day, +/- 1×10^{-8} /0 - 50°, 1×10^{-6} / year
External:	10.000 MHz, 0.4 - 2.0V _{rms} into 300 Ω ; 5.000 MHz, 0.5 - 2.0V _{rms} into 300 Ω

Auxiliary Outputs (50 Ω):	10.000 MHz, \geq 3.5 dBm (3 identical outputs) 22.000 MHz, \geq 4dBm, -35 dBc harmonic rejection 80.000 MHz, \geq 4.5 dBm, -35 dBc sideband rejection
Operating Ambient:	0 - 55° C, 95% relative humidity, 0 - 2, 000m
Power:	120/220VAC +/- 10%, 50 - 60 Hz, 60W
IEC Installation category:	II
IEC Pollution degree:	2
Dimensions:	19 x 3.5 x 17.0 inches max. (rack or bench cabinet)
Weight:	40 lbs

Installation

3

Caution

3.1

CAUTION: Refer to **Primary Power**, page 14, before connecting instrument to line voltage.

Safety Declarations

3.2

This product was designed and manufactured in accordance with international safety standards. Before connecting the instrument to line voltage, review all product instructions.

When properly used, this instrument does not present any hazard. Voltages inside this instrument, however, are dangerous and may be fatal. Careless or improper use can lead to accidents; refer to the Operation section of this manual before use. Service should be attempted by qualified personnel only; disconnect the power supply before servicing.

If this device is operated outside of its stated specifications, or in a manner not specified, protection provided by the equipment may be impaired.

Safety Symbols



The product will be marked with this symbol when it is necessary for the user to refer to the instruction manual (refer to the **Table of Contents**).



Indicates earth (ground) terminal.

Unpacking

3.3

Your instrument has been built, tested and packed carefully and should reach you in perfect mechanical and electrical condition. Please inspect both the carton and the cabinet upon receipt for evidence of damage that might have occurred in transit. In case of damage or defect, a claim must be filed with the carrier immediately.

Dimensions and Weight

3.4

Outside cabinet dimensions of the instrument for both the rack and bench versions are given in Figure 4.1. The weight of the instrument is approximately 40 lbs.

Figure 3.1. Cabinet Dimensions

CABINET DIMENSIONS

Bruker DL310, DL620, SL310, SL620

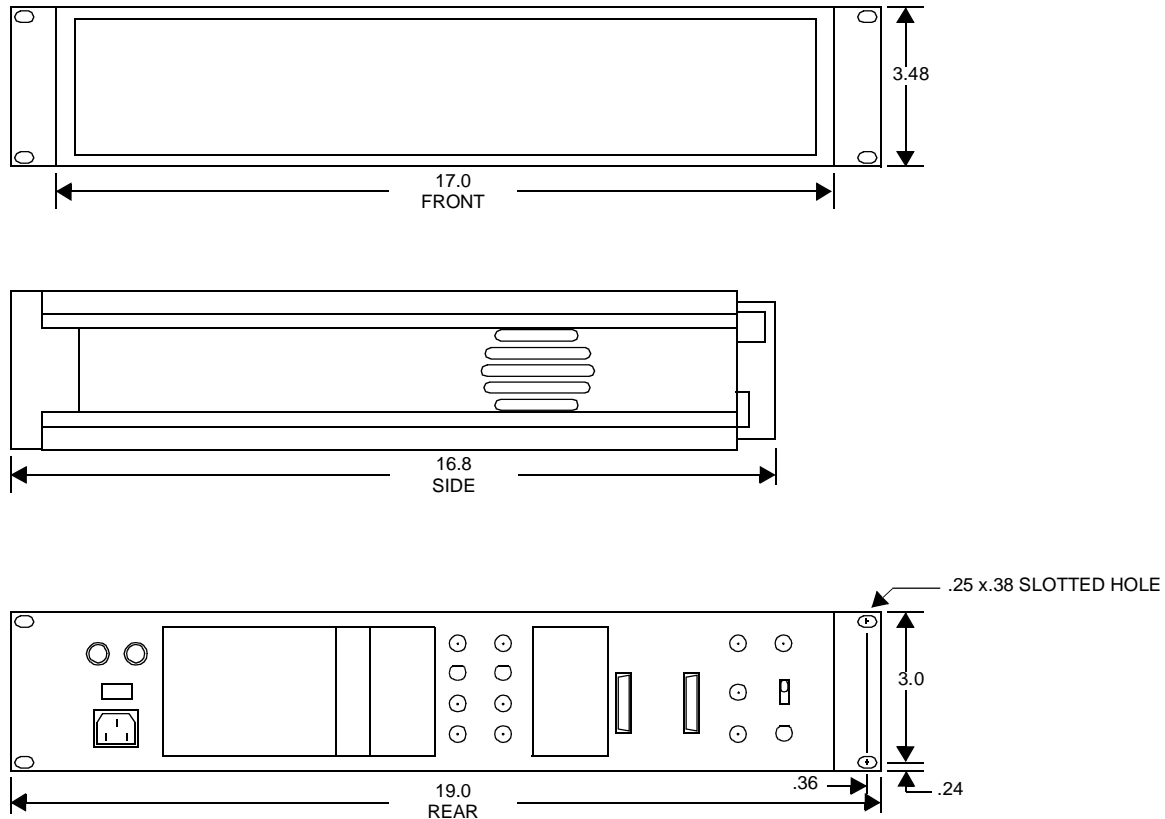

nil h:\prelim\projects\pts\bloc\960306\pts4_1.mif

Primary Power

3.5

The PTS DL620 is designed to operate from power lines with 120 or 220 VAC +/- 10%, 50 - 60 Hz. Instruments are equipped with a line-voltage selector switch located on the rear panel (see ***Rear Panel Controls and Connectors***, page 21). Before operating your instrument, be certain that it has been connected and fused for your line voltage. Improper connection may lead to damage of the instrument.

Proper grounding of the mainframe to the neutral or ground of the power system is accomplished via a NEMA-approved receptacle and 3-wire power cord in the United States. For the safety of the operator, an approved adapter must be used with 2-wire outlets. This adapter must provide positive connection to the electrical conduit or other low resistance ground. In the European Community, a harmonized line cord with conductor cross section of greater than 0.75 mm², certified by a recognized national body, must be used.

The power consumption of the PTS DL620 is approximately 60 watts.

Bench Use**3.6**

For bench use the PTS DL620 is equipped with a fold-down tilt stand. Stacking of the instrument is permissible, provided that air-intake for the side-mounted fan and convection cooling of the heat sink on the rear panel are not impaired by deep, overhanging cabinets.

Rack Mounting**3.7**

The PTS DL620 may be mounted to a standard 19 inch relay rack, if ordered with the rack mounting option. Insure that air-intake for the side-mounted fan and convection cooling of the heat sink on the rear panel are not impaired. Where shock or vibration are encountered, it is suggested that rear or side supports be provided for the instrument.

Performance/ Incoming Inspection Testing

4

General

4.1

The following optional minimum performance or incoming inspection tests may be performed to ensure that the instrument is operating correctly. Equipment required to perform the tests is listed below:

Equipment	Recommended Model
Frequency Counter, 0 - 620 MHz	HP 5383A
Power Meter, 0 - 20 dBm	HP 435B/8482A
Spectrum Analyzer, 0 - 1000 MHz	HP 8558B/182T

Frequency Verification

4.1.1

(to be performed independently on programmable channel F1 and F2)

Connect the output of the frequency synthesizer to the input of the counter.

Connect the 10 MHz output of the counter (set to INT) to the synthesizer rear-panel 5/10 MHz external frequency standard input, and set the synthesizer rear-panel frequency standard selector switch to EXT STD (see [Rear Panel Controls and Connectors](#), page 21, for more information on these connectors). Connect a 4.0 MHz, 0 dBm signal to the channel's fine resolution input.

Use the remote control interface to set the synthesizer's output frequency (see [Rear Panel Controls and Connectors](#), page 21 for more information on this interface). Check that the synthesizer frequency is correct by observing that the counter reading and synthesizer setting are in agreement at the following frequencies (listed in MHz):

3.0
11.0
22.0
33.0
44.0

55.0
66.0
77.0
88.0
99.0
100.000 000 0 through 290.000 000 0 in 10 MHz steps
300.0
302.0
304.0
306.0
308.0
310.0
312.0
314.0
316.0
318.0
400.000 000 0 through 610.000 000 0 in 10 MHz steps
618.0

Output Level Verification

4.1.2

(to be performed on channel F1 and F2)

Connect the probe of the power meter to the output of the synthesizer. If the synthesizer has an internal frequency standard, set the rear-panel frequency standard selector switch to INT STD.

Set the output frequency to 100 MHz. Check that the output level is +4 dBm +/- 0.7dB.

Check that the output level does not vary more than a total of 1.4 dB over the entire frequency range (3.0 - 619.999 999 9 MHz) of the synthesizer.

Harmonic, Subharmonic and Spurious Output Verification

4.1.3

(performed on channel F1 and F2)

Connect the output of the synthesizer to the spectrum analyzer input.

Make the necessary adjustments on the spectrum analyzer so that the full output spectrum may be observed, making sure that the input is not over driven.

Check that all harmonics are 30 dB or more below the main output over the entire frequency range (3.0 - 619.999 999 9 MHz) of the synthesizer.

Check that all 1/2 and 3/2 fouth subharmonics are below the specification levels (see **Specifications**, page 9) over the 300 - 620 MHz frequency range of the synthesizer.

Check that spurious outputs are below the specification levels (see **Specifications**, page 9).

Frequency Standard Verification

4.1.4

(not applicable to instruments with no internal standard)

Set the rear panel frequency standard selector switch to INT STD, and allow the instrument to warm up for at least 20 minutes.

Connect the rear panel 10 MHz OUT (frequency standard output) to the input of the counter, which must now be driven from a suitable calibrated reference standard.

Check that the measured frequency is 10 MHz +/- 2 Hz. If adjustment is necessary, follow the procedure detailed in 10 MHz **Internal Frequency Standard Calibration**, page 36.

Operation

5

Power Connection

5.1

Before attempting to connect the instrument to the primary power, verify proper line voltage connection and fusing (see ***Primary Power***, page 14).

Warm-Up

5.2

The PTS DL620 is operative on turn-on. If the instrument is to operate from the internal OCXO standard, a period of 20 minutes is required at 25° C ambient for the frequency to be within $\pm 1 \times 10^{-7}$ of nominal. In general, it is desirable to operate the equipment continuously for best frequency stability.

Internal-External Frequency Standard

5.3

The synthesizer may be operated from either the internal or an external frequency standard (5.0 or 10.0 MHz). For internal standard operation, the frequency standard selector switch (rear panel) must be set to INT STD; for external standard operation, the switch must be set to EXT STD. Note that for internal standard operation, the switch must be set to INT STD even if no external standard is connected; otherwise, no output is generated.

Rear Panel Controls and Connectors

5.4

Figure 6.1 shows rear panel controls and connectors for frequency programming, and main and auxiliary inputs and outputs.

REAR PANEL

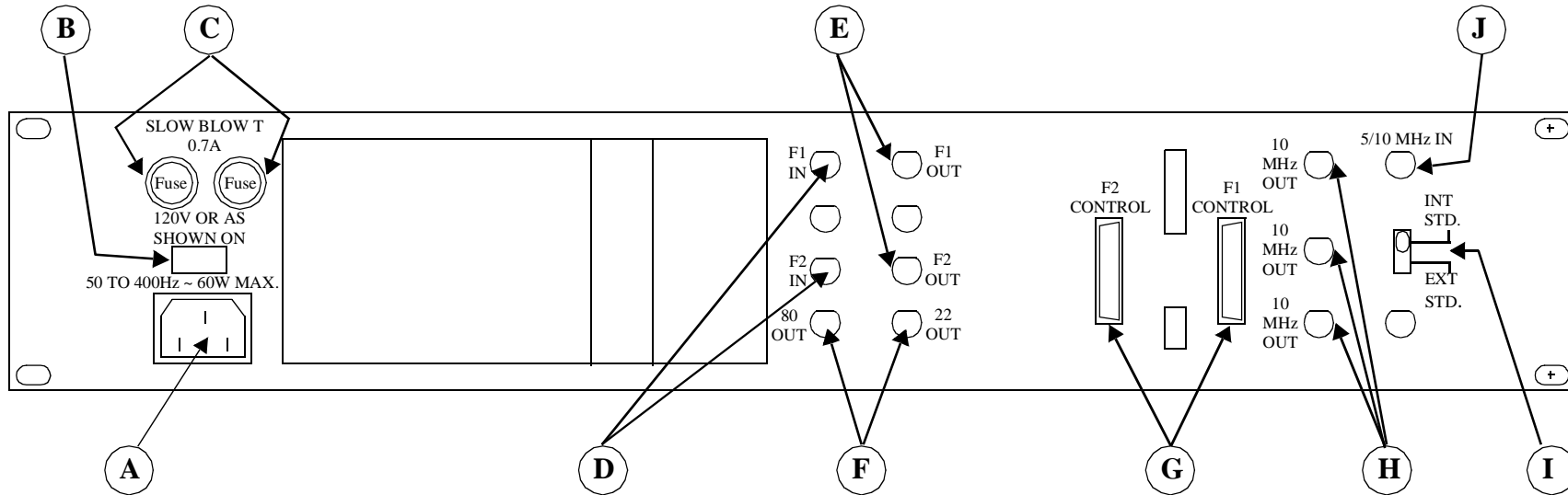

nil h:\prelim\projects\pts\bloc\960306\pts6_1.mif

- (A) 3-Wire Primary Power Cord Receptacle - Accepts power cord for instrument operation.
- (B) Line Voltage Selector Switch - Selects line voltage for instrument operation.
- (C) Fuse Holders - Fuse rating and primary supply voltage for the instrument are indicated beside the fuse holders.
- (D) F1 and F2 Input - SMA connectors accept 3.0 to 4.0 MHz, 0 dBm fine-resolution input for each channel.
- (E) F1 and F2 Output - SMA connectors supply programmable output for each channel.
- (F) Auxiliary Frequency Outputs - SMA connectors supplying auxiliary frequency outputs as labelled.
- (G) Remote Programming Connectors - Yamaichi 36-pin NCS-036-032-DS connectors which require Yamaichi NCP-036-032-DS connectors for control. These connectors allow remote frequency programming. All functions connect directly to HCPL 2630 opto-coupler/opto-isolator interface ICs. A complete pin-out of this connector is given in Table 11.1. See also Remote Frequency Programming, below.
- (H) 10 MHz Frequency Outputs - SMA connectors supply 10.0 MHz, +3.5 dBm outputs which may be used to drive other synthesizers without internal standards as slaves.
- (I) Frequency Standard Selector Switch - Slide switch which selects between an internal or external frequency standard. This switch must be set to INT STD if no external frequency standard is provided.
- (J) 5/10 MHz External Frequency Standard Input - SMA connector accepts external frequency standard of either 5.0 or 10.0 MHz, 0.4 - 0.6V into 300 ohms to control instrument. **Important:** see also Frequency Standard Selector Switch, above.

NOTE: The location of listed inputs and outputs is subject to change. Refer to instrument's rear panel labelling for actual location of listed inputs and outputs.

Figure 5.1. Rear Panel

The channel F1 and F2 output frequencies are remotely programmable through the Yamaichi 36-pin connectors located on the rear panel. Table 1 lists the pin assignments for the NCS-036-032-DS-type connectors. All programming on this connector is level (or state) triggered and employs TTL-level-compatible logic; see Table 1 for a complete listing of valid programming voltage levels. Frequency programming employs TTL-level-compatible negative true logic; the DOUBLE signal programming employs TTL-level-compatible positive true logic. Output signal level for each channel is set via internally-located potentiometers.

The programming format for frequency control is parallel entry 4 bit BCD (1, 2, 4, 8 weighting) for each digit. By default, all frequency programming pins are internally pulled to a high (false) state, and both channel (F1 and F2) DOUBLE signals are pulled to a high (true) state.

To program a channel to a specific frequency in the range 3.000 000 0 to 299.999 999 9 MHz, the appropriate frequency control pins to set the 100 MHz through 1 MHz digits must be brought to the low (true) state, and the appropriate channel DOUBLE signal brought to a low (false) state. A 3 to 4 MHz (0 dBm level) fine resolution signal, containing any 100 KHz and finer resolution steps as a negative offset from 4 MHz, must be connected to the appropriate channel's fine-resolution input connector. See also **1 MHz Step Section**, page 27.

To program a channel to a specific frequency in the range 300.000 000 0 to 619.999 999 9 MHz, the appropriate frequency control pins to set the 100 MHz through 1 MHz digits to one half of the desired output frequency must be brought to a low (true) state, and the appropriate channel DOUBLE signal brought to a high (true) state. A 3 to 4 MHz (0 dBm level) fine resolution signal, containing the appropriate one half frequency 100 KHz and finer resolution steps as a negative offset from 4 MHz, must be connected to the appropriate channel's fine-resolution input connector. See also **1 MHz Step Section**, page 27.

For the 1 MHz digits, remote frequency programming changes result in an output signal at the new frequency (within 0.1 radian) within 5 μ seconds; for the 10 MHz and 100 MHz digits, frequency changes are effected within 20 μ seconds.

Output level is under internal potentiometer control. Each channel's output signal can be independently set to a level between +2 and +6 dBm.

See also **Opto-Coupled Parallel Entry Boards OPE-2013**, page 38.

Principle of Operation

6

General

6.1

An overview of the system is presented in this section by discussing the block diagram in Figure 7.1. Figure 7.2 shows the location of the modules discussed. The material presented here is essential for efficient service, and familiarity with it is assumed in the service instructions.

All output frequencies of the PTS DL620 are derived from the 10 MHz frequency standard (either internal or external) by arithmetic operations and are fully coherent with this standard. The instrument uses a simplified direct synthesis in which all auxiliary fixed frequencies are produced from a 10 MHz pulse. For each channel, the final output frequency is derived from a beat-frequency system as follows:

A signal of 355 to 365 MHz, which carries all 0.1 Hz to 1 MHz steps, is subtracted from a 365 to 665 MHz signal, which carries the 10 MHz steps. The resultant output ranges from 1.0 MHz to 309.999 999 9 MHz. However, 3.0 MHz is the practical cutoff in the output amplifier; lower frequencies could otherwise be obtained. Frequencies from 300.0 to 619.999 999 9 MHz are produced by doubling.

The block diagram (figure 7.1) shows a crystal oscillator (which is the prime reference in the system), a Standard Frequency Section, and for each channel F1 and F2, a Remote-Control Interface Section, a 1 MHz Step Section, a 10 MHz Step Section, and a Doubler/Output Amplifier Section. The block diagram also shows a number of additional auxiliary frequency generating modules, discussed below.

PTS DL620 BLOCK DIAGRAM

F1 CHANNEL

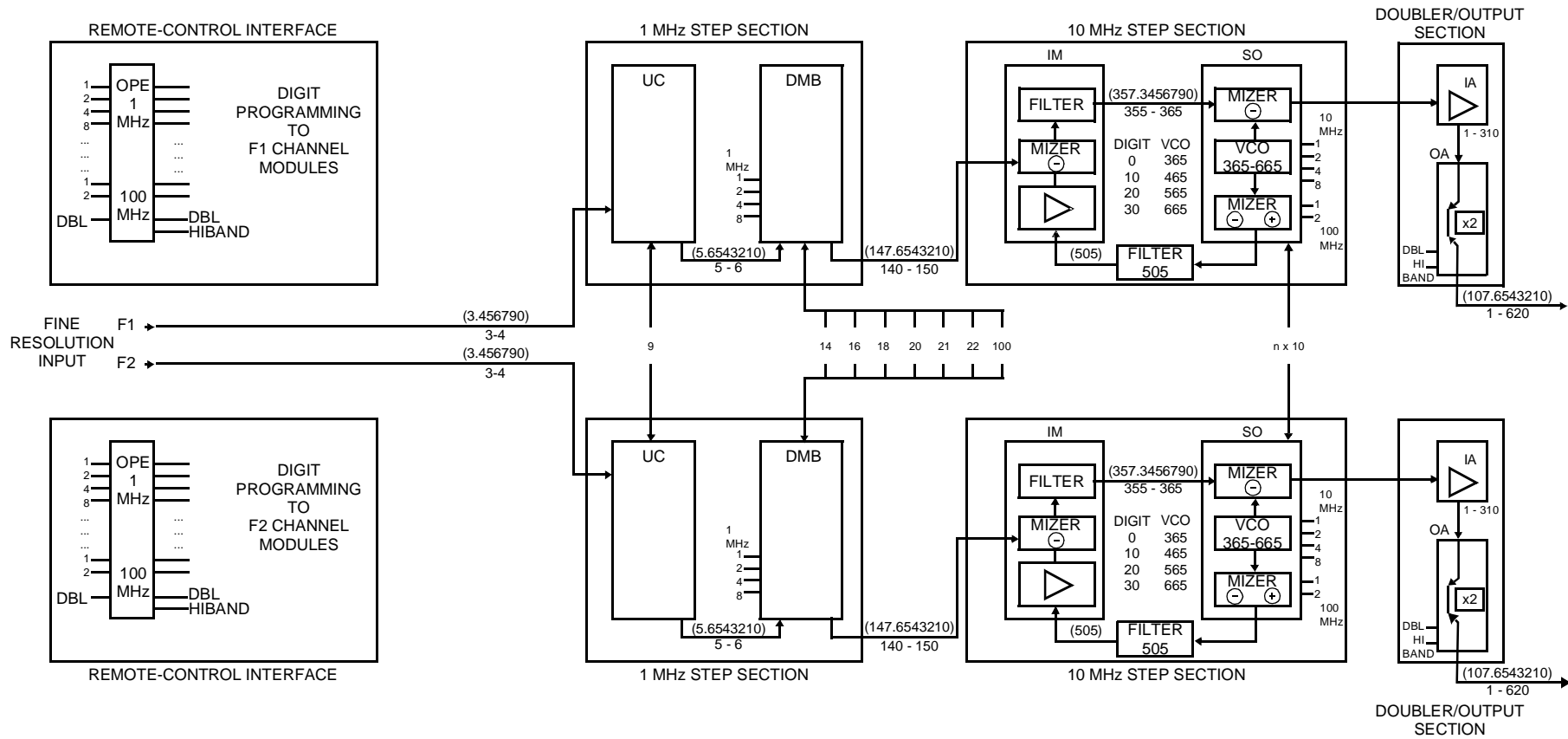

F2 CHANNEL

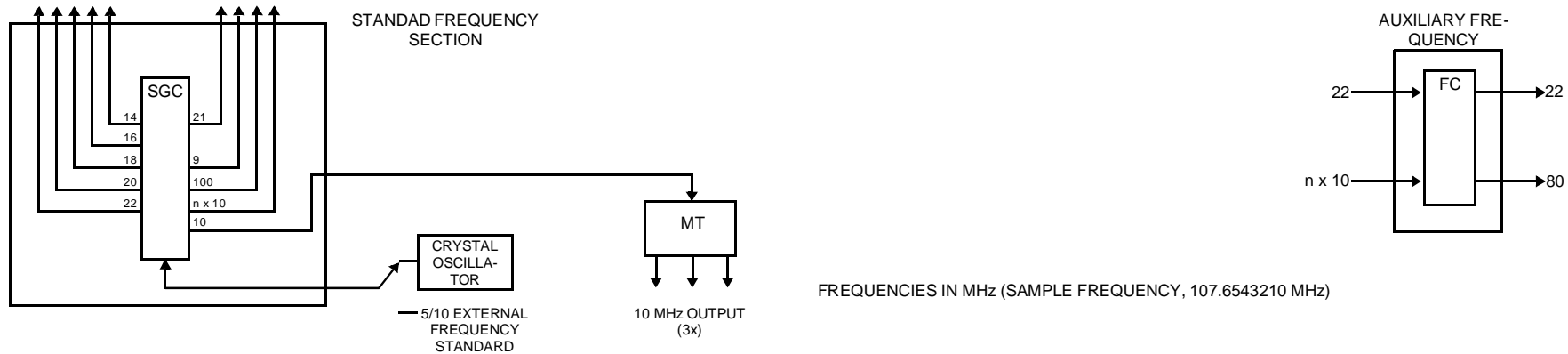

FREQUENCIES IN MHz (SAMPLE FREQUENCY, 107.6543210 MHz)

Figure 6.1. PTS DL620 Block Diagram

Standard Frequency Section**6.2**

This section consists of the SGC (Standard Generator type C) module. Operating from an input of 10.000 MHz (or an automatically doubled 5.000 MHz input), the module provides all fixed standard frequencies used in the instrument.

The filtered 10 MHz signal is fed to a pulse generator, where harmonics of 20 MHz through 160 MHz are generated with equal amplitude. This „picket fence“ is the basis for all standard frequencies. Through arithmetic operations on this picket fence, the SGC module generates 9,14, 16, 18, 20, 21, 22 and 100 MHz for use in the 1 MHz Step Section. The 10 MHz picket fence (10 - 160 MHz) from the SGC is also supplied to the 10 MHz Step Section. Various selected frequencies are also used by auxiliary frequency-generating modules.

Remote-Control Interface Section**6.3**

For each channel F1 and F2, this section consists of the OPE (Opto-coupled Parallel Entry) module. Operating from the user-supplied F1 or F2 negative-true logic level programming, the module generates positive-true control signals for all functions. In addition, the module generates the filter switching signal „HIBAND“ for use in the channel's output amplifier (OA) module; this logic detection is performed in a custom-programmed IC.

1 MHz Step Section**6.4**

For each channel F1 and F2, this section consists of the UC (Up-Converter) and DMB (Digit Type B) modules. Operating from the user-supplied F1 or F2 fine-resolution input, the function of the UC module is to shift this signal to a 5 MHz carrier suitable for the following DMB module. The DMB modules add the 1 MHz step for each channel and also transfer the information to a frequency which can more readily carry a 10 MHz bandwidth.

For each channel F1 and F2, the fine-resolution input is a 3.0 to 4.0 MHz signal carrying the 100 KHz and finer resolution increment in a negative offset from 4.0 MHz., i.e., an input of 3.9 MHz corresponds to a 100 KHz offset, 3.8 MHz to a 200 KHz offset, etc. For example, if a frequency of 0.543 210 MHz is desired by the user for the 100 KHz and finer steps, the fine-resolution input must be 3.456790 MHz. In the UC module, this signal is mixed with 9 MHz, and the lower sideband selected. The result is a 5 to 6 MHz signal which carries the 100 KHz and finer frequency resolution increment as a positive offset from 5.0 MHz. Continuing with the above example, the output of the UC module will be 5.543 210 MHz.

For each channel F1 and F2, the DMB module adds the 1 MHz step and also transfers the information to a frequency which can more readily carry a 10 MHz bandwidth. The carrier at the output of the DMB module is 140 MHz. If the above example is expanded to include a setting of 6.543 210 MHz for the 1 MHz through 0.1 Hz steps, then the output of the DMB module will be 146.543 210 MHz.

For each channel F1 and F2, this section consists of the IM (Intermediate Mix) and SO (Stepped Oscillator) modules, and the 505 MHz cavity filter. In this section, frequencies are used which are not derived from the frequency standard. Frequencies mentioned in previous paragraphs were all as accurate as the 10 MHz reference frequency. Here, however, the VCO frequencies from 365 to 665 MHz (in 10 MHz steps) may differ from their nominal values by as much as 1 MHz. As explained below, such deviation from nominal values has no effect on the accuracy of the final output frequency. The Stepped Oscillator operates in a drift-cancelled loop which serves two functions:

1. Selection and filtering of one of sixteen 10 MHz pickets by a fixed 505 MHz filter.
2. Supply of frequencies high enough for the final mixer, with a high degree of coherence in the two mixer inputs.

The block diagram lists VCO frequencies corresponding to selected 10 MHz steps as examples. These will be helpful in understanding the complete synthesis process via the sample frequency.

Continuing with the sample frequency of the previous sections, and assuming that the 10 MHz digit has been set to 10, the complete frequency setting is 106.543 210 MHz. As listed in the block diagram, for a digit setting of 10 the VCO will produce a frequency of 465 MHz, which is fed to two different mixers. In the SO module picket fence mixer, the picket fence frequency of 40 MHz will add to the 465 MHz and feed 505 MHz through the filter and into the IM module. In the IM module, the 505 MHz is mixed with the 146.543 210 MHz output of the 1 MHz Step Section. A 355 to 365 MHz bandpass filter at the top of the IM module selects the lower sideband of this mix; for the current example, the selected frequency is 358.456 790 MHz. The selected frequency is then fed to the SO module final output mixer, where it is mixed with the VCO frequency of 465 MHz. A low-pass filter selects the resultant difference of 106.543 210 MHz, the desired output frequency.

As can be seen, the VCO feeds both inputs to the final output mixer, one directly and the other after an intermediate mix. Therefore, if the VCO frequency deviates from nominal, both mixer inputs deviate from nominal by the same increment. This obviously does not alter the difference between these two frequencies, which is the desired output frequency.

Doubler, Output Amplifier and Level Control

6.6

For each channel F1 and F2, the final output from the 10 MHz Step Section is a signal in the 1.0 - 309.999 999 9 MHz frequency range. For frequencies in the 300.0 - 619.999 999 9 MHz band, a doubler is employed. For desired output frequencies of 300 MHz and above, the user must program one half the desired output frequency, and assert the appropriate channel DOUBLE signal, so that the output of the 10 MHz Step Section when doubled is the correct output frequency.

The output from the 10 MHz Step Section is a low-level signal. The IA (Intermediate Amplifier) and OA (Output Amplifier) modules provide the necessary doubling (under user-command), filtering, wideband gain and levelling of amplitude to produce instrument outputs up to +6 dBm across the band from a 50 ohm source-impedance with substantially flat response from 3.0 to 620 MHz.

Figure 6.2. PTS DL620 Module and Test Point Locations

PTS DL620 MODULE AND TEST POINT LOCATIONS

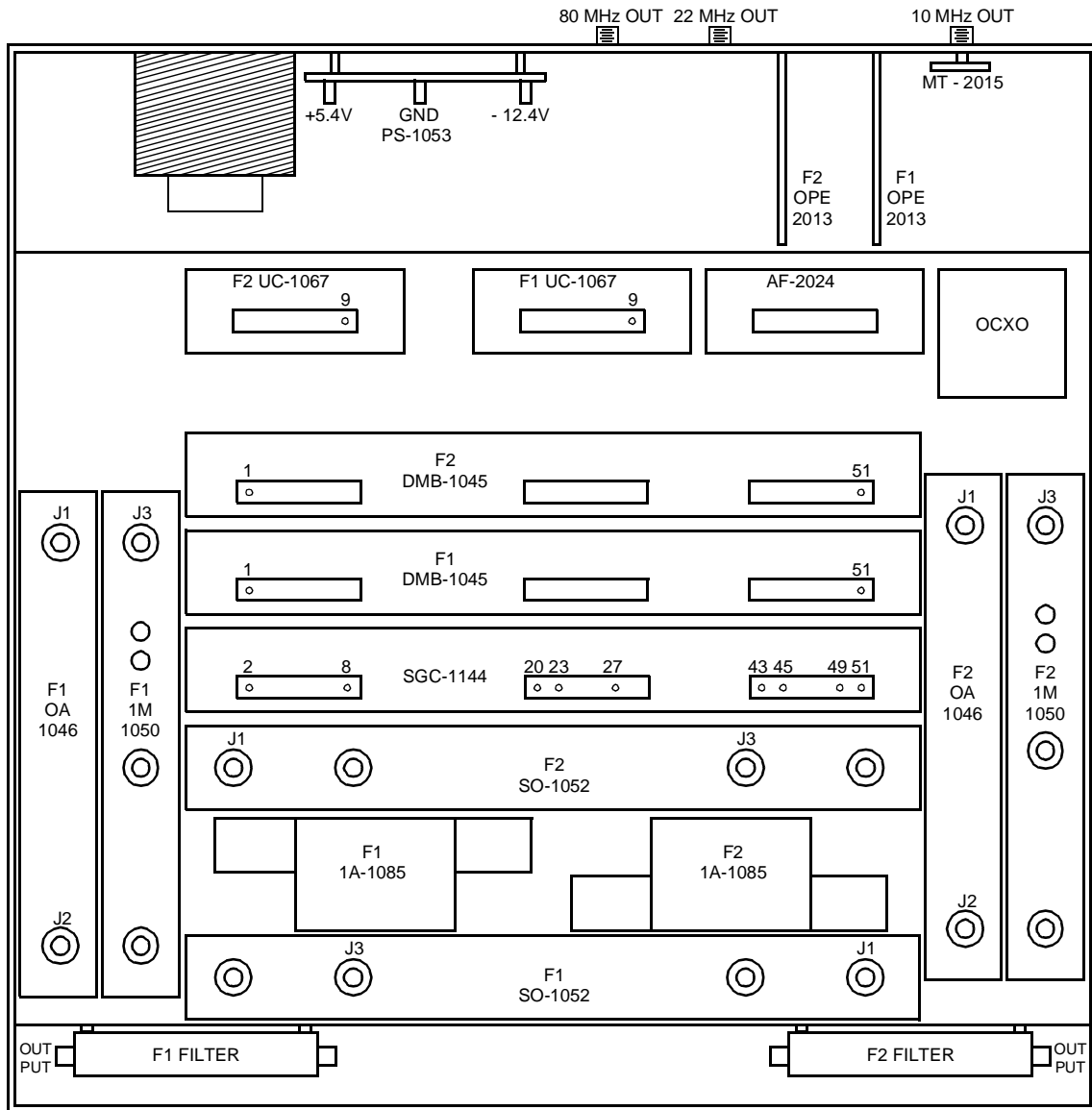

DIAGRAMATIC VIEW FROM BOTTOM OF DECK

Auxiliary Frequency-Generating Modules

6.7

The PTS DL620 also includes modules to generate a number of auxiliary frequencies, as follows.

Operating from 10 MHz derived from the frequency standard, the MT-2015 (Multiple 10 MHz) module generates three coherent 10 MHz sine-wave output signals at a level of +3.5 dBm.

Principle of Operation

The AF-2024 (Auxiliary Frequency) module generates two auxiliary frequencies, as follows:

1. Operating from 22 MHz, the module generates a decoupled 22 MHz sine-wave output signal at a level of +4 dBm.
2. Operating from the 10 MHz picket fence, the module filters and amplifies the appropriate picket to generate a decoupled 80 MHz sine-wave output signal at a level of +4.5 dBm.

Caution

7.1

CAUTION: When properly used, this instrument does not present any hazard. Voltages inside this instrument, however, are dangerous and may be fatal. Careless or improper use can lead to accidents. Disconnect power supply before opening; service by qualified personnel only!

General

7.2

In general, no preventive maintenance is required for the PTS DL620. Minor recalibration of the instrument may be performed annually as described in the **Calibration section**, page 35.

Unless used in an abnormally dusty environment, no cleaning of this instrument is required.

The PTS DL620 contains no user-serviceable parts. Should the instrument require service, the System Troubleshooting section provides information which permits identification of a defective module. In the case of malfunction, all modules are easily removed from the deck and replaced; defective modules must then be returned to the factory for service.

System Troubleshooting

7.3

⇒ **EXTREMELY IMPORTANT!**

For operation, the unit must be driven from either an internal or external 5 or 10 MHz frequency standard, and the Frequency Standard Selector Switch set to INTSTD or EXT STD, accordingly (see **Rear Panel Controls and Connectors**, page 21). After verifying that a frequency standard is correctly connected and/or selected, if no instrument output is present, proceed as described below.

The following test equipment is recommended for troubleshooting:

RF-Voltmeter V

1 - 620 MHz, 10 mV - 1V, high impedance probe (3 pF, DC resistance 100K Ω)

HF-Counter C

0 - 620 MHz or 0 - 160 MHz, 10 mV sensitivity, high impedance or 50 Ω input, 1 Hz resolution; input for External Drive for synchronization with 10 MHz standard, 0.5V into 50 Ω

Spectrum Analyzer SA

10 - 1000 MHz, 50 Ω input; min. 60 dB on-screen dynamic range; max. BW 1 MHz; min. sensitivity - 40 dBm

Multimeter

Analog or digital; 0-15V, 0.1V resolution; 0-2A, 0.1A resolution

Test equipment is referred to in Table 2 as noted above (V, C, SA). The Voltmeter and Counter must have high DC input resistance since connection is made to points with +5.4V potential. The RF-Voltmeter probe connects directly to test points. The Counter is connected via an RG 174 or similar cable equipped with small alligator clips. The Spectrum Analyzer is connected via cables equipped with SMA and SMB connectors and via a high impedance 500 Ω (10X) probe.

NOTE:

Either the 5/10 MHz input or the 10 MHz output can be used to synchronize the Counter in the troubleshooting of an instrument. For **complete** correspondence of remote control settings and counter readings, synchronization is **required**; otherwise, any differences between the two frequency standards will result in differences between settings and readings.

Connect the instrument to the AC power line.; the operation of the side-mounted venting fan will serve as an AC line power indicator. Check the AC power line fuses if no indication is obtained. Use only a fuse of the proper rating as a replacement. If AC line power is present, program a test frequency by remote control (see [Operation](#), page 21).

If no output is obtained, check a rear panel 10 MHz OUT. A 10 MHz, +3.5 dBm output should be obtained. If no 10 MHz signal is present, insure that a 5 or 10 MHz frequency standard has been properly connected and/or selected. For instruments operating on an internal frequency standard, set the Frequency Standard Selector Switch set to EXT STD and connect an external 5 or 10 MHz frequency standard; if the instrument now functions properly, the internal frequency standard is defective and must be replaced.

If, after these steps, the instrument still does not operate properly, the instrument's top and bottom covers must be removed for further testing. Disconnect the unit from the power line; remove the screws attaching the covers, and carefully remove them.

After the unit is again powered, check for the presence of supply voltages -12.4V (blue wire) and +5.4V (green wire) at the terminals of the power supply on the rear panel. If voltages are within +/- 0.2V, proceed to the next step; if voltages are absent or low, measure current in the leads from the power supplies. The proper 12.4V current is 1.5 - 1.8A (dependent on the crystal oven temperature); the proper 5.4V current is 1.0 - 1.3A. Improper or missing currents indicate a faulty power supply, or a short or overload within the instrument.

If a fault is localized to a particular decade (e.g., all 1 MHz steps defective), or to a particular bit within a decade (e.g., 1 bit defective in the 1 MHz decade, resulting in only even 1 MHz steps), perform a careful DC voltage and continuity check of the related control signal wiring and processing with the aid of the following functional descriptions and schematics:

Opto-Coupled Parallel Entry Boards OPE-2013, page 38

Figure 7.1: **PTS DL620 Block Diagram**, page 26

Figure 11.3: **OPE-2013 Schematic**, page 44

Insure that valid TTL-level positive-true control signals are delivered to all related synthesis modules.

Assuming that proper supply voltages are present and that wiring and logic IC faults on the OPE-2013 modules have been eliminated, the tests described in **table 11.2** will identify a defective module. Table 2 lists test points and expected signal frequencies and levels; Figure 7.2: **PTS DL620 Module and Test Point Locations** shows the location of the test points.

To perform a full diagnostic check, all test instruments with the upper frequency limits are required. However, it is possible to complete some tests of the instrument with the RF-Voltmeter and the 160 MHz Counter. Proceeding from the crystal oscillator, through the Standard Frequency Section and the 1 MHz Step Section, most tests for presence of signal and proper frequency can be made bridging, without opening connections. Tests of these sections will cover most of the instrument. To test the 10 MHz Step Section and the Doubler/Output Amplifier Section, 50 ohm SMA and SMB connections must be made.

In general, no preventive maintenance is required for the PTS DL620. The presence of an output signal of the correct frequency indicates that the instrument is functioning properly. To offset the effects of aging and insure uninterrupted proper instrument operation, minor recalibration of the SO-1052 modules may be performed annually; the SO-1052 Module Calibration section below provides the information necessary to perform this.

For instruments equipped with an optional internal 10 MHz frequency standard, recalibration of the frequency standard should be performed on a schedule dictated by the user's accuracy requirements and the specified drift characteristics of the optional frequency standard; see *Crystal Oscillator OCXO* (XT-1012) or *TCXO* (XT-1013), page 37, and *10 MHz Internal Frequency Standard Calibration*, page 36.

Over long periods of time, minor recalibration of the SO-1052 modules may become necessary due to aging of the module's tuned circuits. The 10 MHz steps of the SO-1052 module (365 to 665 MHz) must be within +/- 1.0 MHz for proper operation of the instrument. **However, since each SO-1052 module operates inside a drift-cancelled loop, any frequency errors within +/- 1.0 MHz do not affect the overall accuracy of the output frequency;** see *Principles of Operation*, page 25.

The following adjustments assume familiarity with the procedures described in *System Troubleshooting*, page 31. For these adjustments, the instrument must be at operating temperature after having warmed up for at least 3 hours. After warm-up, remove the instrument's top and bottom covers. Pots for the adjustment of all 10 MHz steps are accessible after removing the aluminum tape over the slot on the top of the SO module. Oriented from the front of the unit, for the F1 channel (**front** SO module), step 0 corresponds to the right-most pot, step 1 to the adjacent pot, and so on through step 30, the left-most pot; for the F2 channel (back SO module), step 0 corresponds to the left-most pot, continuing through step 30, the right-most pot.

For each channel, Step 20 of the troubleshooting procedure (see *table 11.2*: System Trouble-shooting) allows the measurement of a 365 MHz IF frequency generated by all 10 MHz steps in the undoubled range. With the 1 MHz step programmed to zero and the channel's fine-resolution input set to 4.0 MHz, proceed through all 10 MHz steps (31 steps, 0 - 300 MHz), observing the frequency on the Counter. For each step, adjust the appropriate pot so that the Counter reading is 365 MHz +/- 0.2 MHz. In general, it is necessary for aluminum shielding tape to cover pots not being adjusted (i.e., uncover the pots corresponding to the first five steps, leaving the remainder of the tape in place; after completing these

steps, replace the tape and proceed to the next five steps). After completing all steps, be sure that aluminum shielding tape covers all slot openings.

(**Note:** Some models of PTS DL620 synthesizers require the use of non-slotted SO-1052 module covers. In these cases, an alignment cover with access slots, purchased from the factory, must be temporarily installed for the calibration procedure and subsequently removed.)

10 MHz Internal Frequency Standard Calibration

8.3

For instruments equipped with an internal OCXO frequency standard, calibration of the standard at periodic intervals may be necessary due to normal aging of the standard's quartz crystal. All quartz crystal oscillators are secondary standards which require a primary reference for calibration. PTS oscillators are set to within 1×10^{-7} of nominal at the time of delivery from the factory. Thereafter, these oscillators are subject to the time-drift and temperature-drift given in the specifications (see ***Crystal Oscillator OCXO*** (XT-1012), page 20). A suitable recalibration interval must be determined by the user, and should take into account the accuracy requirements of the user's particular application, and the drift specifications of the oscillator supplied with the instrument.

For this adjustment, the instrument **must** be at operating temperature after having warmed up for at least 3 hours. After warm-up, **without** disconnecting or turning off the primary power, remove the instrument's top cover. Each oscillator includes a potentiometer for frequency adjustment which is accessible from the top of the oscillator beneath a screw-cover; remove the adjustment-pot cover.

Connect the rear panel 10 MHz OUT (frequency standard output) to the input of a frequency counter driven from a **suitable primary reference standard**. Insure that the rear panel Frequency Standard Selector Switch is set to INT STD. Carefully adjust the internal standard's frequency so that the counted frequency reads 10 MHz +/- 1 Hz. After completing the adjustment, reinstall the adjustment-pot cover, and carefully reinstall the instrument's top cover.

Mainframe Components

9

Power Supply PS-1053

9.1

The PS-1053 board, operating from commercial power lines, generates DC voltages of +5.4V and -12.4V. The +5.4V is used for TTL and MECL logic (fed by decoupling networks), and the -12.4V powers transistor amplifiers. Maximum current is 3.0A at +5.4V and 2.0A at -12.4V, approximately.

Both regulators operate from capacitor input filters, fed by silicon rectifier bridges. The series-pass transistor, gain and reference elements are integrated in a TO-3 package which is heat-sunk to the rear panel. Both supplies are short-circuit proof with fold-back current limiting.

The transformer uses paralleled primaries for 120V input or optional switch-selectable 220-230V input.

In case of malfunction, refer to the schematic (Figure 11.1: ***PS-1053 Schematic***) which lists essential DC voltages for both supplies to locate the faulty component or replace the supply-board as a unit.

Crystal Oscillator OCXO (XT-1012)

9.2

The PTS DL620 may be supplied with a built-in OCXO (XT-1012) crystal oscillator operating at 10 MHz. If installed, it is mounted on the instrument deck and has the following characteristics:

Type:	OCXO (XT-1012)
Frequency:	10.000 000 MHz
Aging:	3×10^{-9} / day, 1×10^{-6} / year
Temperature Coefficient:	$\pm 2 \times 10^{-10}$ / °C
Output:	1Vrms into 500 Ω
Warm-Up Time:	24 hrs for 1×10^{-8}
DC Supply:	-12.4V, 250 mA (500 mA turn-on)

The oscillator has provision for adjustment to compensate for long-term drift.

Opto-Coupled Parallel Entry Boards OPE-2013

9.3

For each channel F1 and F2, these boards contain circuitry to interface remote programming signals for frequency control with the appropriate modules within the instrument. The boards are mounted to the rear of the unit, and each is directly connected with a Yamaichi NCS-036-032-DS input connector. Table 11.1 lists pin assignments for these connectors.

All functions connect directly to HCPL 2630 opto-coupler/opto-isolator interface ICs, and use TTL-level-compatible logic; see **figure 11.1** for a complete listing of valid programming voltage levels. By default, all logic control pins are internally pulled to a high state. The programming format for frequency control is parallel entry 4 bit BCD (1, 2, 4, 8 weighting) for each digit, and employs negative-true logic; the DOUBLE signal programming employs positive-true logic.

See also ***Remote Frequency Programming***, page 23

505 MHz Filter 390-1003

9.4

A 5-section cavity filter forms part of the 10 MHz step section for each channel. The two filters are fixed-tuned and cannot be retuned in the field. The filters are bolted to the instrument deck.

Multi-10 MHz Board MT-2015

9.5

The MT-2015 board provides three 10 MHz sine-wave outputs, suitable for driving other synthesizers as slaves. The board is mounted to the rear of the unit.

Each output, produced by a decoupled emitter-follower transistor circuit, operates from the primary 10 MHz reference standard, and provides a decoupled coherent 10 MHz sine-wave output at a level of +3.5 dBm, approximately.

Schematics

10

Table 10.1. PTS DL620 Channel F1 and F2

REMOTE FREQUENCY PROGRAMMING		
Yamaichi NCS-036-032-DS connector - On PTS Equipment Yamaichi NCP-036-032-DS connector - Required to Control		
<i>Figure 10.1. View of Connector on PTS Equipment</i>		
FUNCTION	SIGNAL	PIN NUMBER
Double Signal	FDPL+	B1
	1MHz+	B2
	2 MHz+	B3
	4 MHz+	B4
	8 MHz+	B5
10 MHz Decade	10 MHz+	B6
	20 MHz+	B7
	40 MHz+	B8
	80 MHz+	B9
100 MHz Decade	100 MHz+	B10
	200 MHz+	B11
	400 MHz+	B12
	800 MHz+	B13
all minus (-) signals	nnnnn-	A1 .. A13
I2C Bus Signals	I2C GND	A14
	I2C VCC+	A15
	I2C Data	B14
	I2C Clock	B15

Frequency and Double Signal Programming

Frequency programming uses **negative** true logic;
DOUBLE signal uses **positive** true logic.

High logic state $V_{Bn} - V_{An}$ differential: 2.8V min., 3.2V max

Low logic state $V_{Bn} - V_{An}$ differential: 0V min, -3.2V min

Table 10.2. System Troubleshooting

Step	Test Point	Frequency (MHz)	Level	Test Equipment	Module Checked	Notes
1	SGC, 51	10.000	0.4V	V, C	Freq. Std.	
2	SGC, 49	10.000	0.4V	V, C	SGC	
3	SGC, 2	14.000	0.1V	V, C	SGC	
4	SGC, 27	16.000	0.1V	V, C	SGC	
5	SGC, 20	18.000	0.1V	V, C	SGC	
6	SGC, 8	9.000	0.1V	V, C	SGC	
7	SGC, 43	20.000	0.1V	V, C	SGC	
8	SGC, 23	22.000	0.1V	V, C	SGC	
9	SGC, 45	100.000	90mV	V, C	SGC	
10	SO, J1	10-160	-17 dBm	SA	SGC	1
11	10 MHz OUT	10.000	3.5 dBm	V, C	MT (3 outputs)	
12	22 MHz OUT	22.000	4 dBm	V, C	AF	
13	80 MHz OUT	80.000	4.5 dBm	V, C	AF	

THE FOLLOWING TESTS TO BE PERFORMED ON MODULES OF EACH CHANNEL F1 AND F2. TESTS REQUIRE FINE-RESOLUTION INPUT OF 4.0 MHz, 0 dBm LEVEL.

14	DMB, 1	22.000	0.1V	V, C	1056 switch	2
15	DMB, 1	21.000	0.1V	V, C	SGC	3
16	UC, 9	5.000	0.15V	V, C	UC	3
17	UC, 9	6.000	0.15V	V, C	UC	4
18	DMB, 51	140.000	0.4V	V, C	DMB	5
19	FILTER OUTPUT	505 +/- 1	-35 dBm	SA	SO, Filter	6
20	IM, J3	365 +/- 1	-16 dBm	C	IM	7

21	SO, J3	0.1 - 309	-30 dBm	SA	SO	8
22	OA, J2	0.1 - 309	+9 dBm	SA, C	IA	9
23	OA, J1	100.000	+4 dBm	SA	OA	3
24	OA, J1	3.0 - 309	+4 dBm	SA	OA, direct band	10
25	OA, J1	300-439	+4 dBm	SA	OA, doubled low band	10
26	OA, J1	440-619	+4 dBm	SA	OA, doubled high band	10

Test point designations show the module and pin number (position) on the board-edge connector, as used in Figure 7.2.

Notes:

1. Open SMB connection at SO, J1. Connect SA to disconnected cable in place of SO, J1. Each 10 MHz multiple from 10 to 160 MHz to be displayed.
2. Set the instrument to 101.000 000 0 MHz, +4 dBm output level.
3. Set the instrument to 100.000 000 0 MHz, +4 dBm output level.
4. Set Fine-Resolution input to 3.0 MHz, 0 dBm level. Return Fine-Resolution input to 4.0 MHz, 0 dBm level setting before proceeding to next test.
5. Program 1 MHz decade through successive steps 0 to 9; test point frequency must increase in 1 MHz increments from 140.000 MHz to 149.000 MHz. Return instrument to 100.000 000 0 MHz setting before proceeding to next test.
6. Program 100 MHz and 10 MHz decades through 31 successive 10 MHz steps 0 - 300 MHz.
7. Program 100 MHz and 10 MHz decades through 31 successive 10 MHz steps 0 - 300 MHz. At each 10 MHz step, program 1 MHz decade through successive steps 0 to 9; test point frequency must decrease in 1 MHz increments from 365.000 MHz to 356.000 MHz.
8. Set Fine-Resolution input to 3.9 MHz, 0 dBm level. Program 100 MHz and 10 MHz decades through 31 successive 10 MHz steps 0 - 300 MHz; test point frequency must increase in 10 MHz increments from 0.1 MHz to 300.1 MHz. At step 31 (300.1 MHz), set 1 MHz decade to 9 MHz, Fine-Resolution input to 3.01 MHz; test point frequency must increase to 309.99 MHz. Return Fine-Resolution input to 4.0 MHz, 0 dBm level setting before proceeding to next test.
9. Open SMB connection at OA, J2. Connect SA to disconnected cable in place of OA, J2. Repeat step 8 above. Return Fine-Resolution input to 4.0 MHz, 0 dBm level setting before proceeding to next test.
10. Set and test instrument over the frequency range indicated.

PS-1053 SCHEMATIC (Power Input, 100-240V AC)

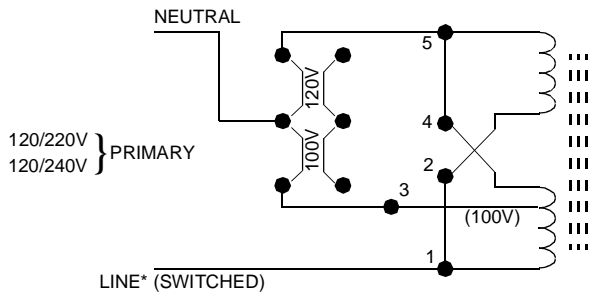
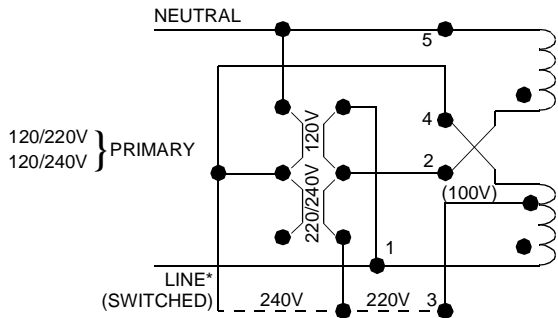
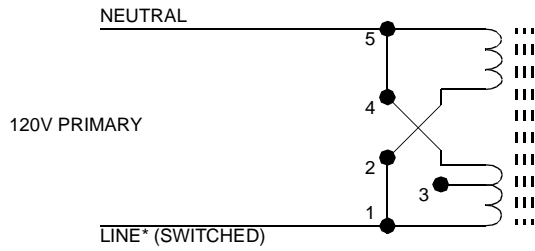

* NO SWITCH IN „REMOTE ONLY“ UNITS

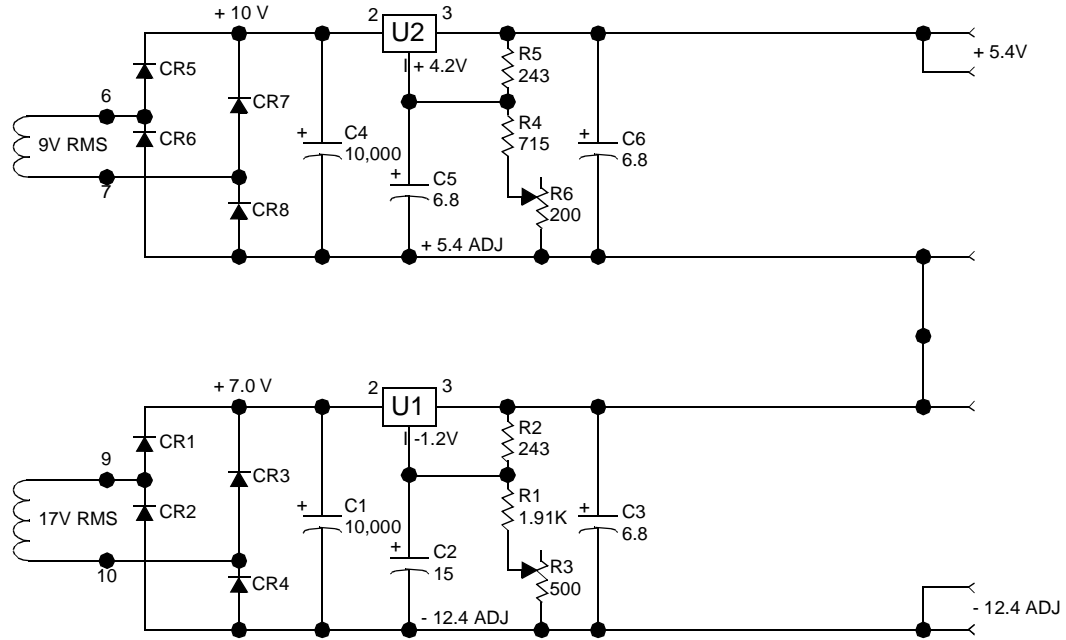
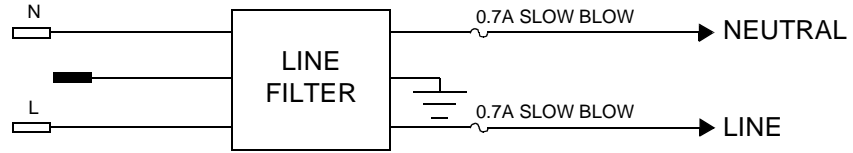

UNLESS OTHERWISE SPECIFIED:
 1. Resistors are in OHMS (Ω).
 2. Capacitors are in Microfarads (uF).
 3. Also valid for: PS1053

**PS-1053 SCHEMATIC
 PS-1019 SCHEMATIC**

Figure 10.2: PS-1053 Schematic

Table 10.3. PS-1053 Parts List

Schematic Designation	Description	PTS P/N
C1	10,000 μ F, 25V	31-5106
C2	6.8 μ F, 25V	30-5101
C3	6.8 μ F, 25V	30-5101
C4	10,000 μ F, 25V	31-5106
C5-C6	6.8 μ F, 25V	30-5101
Resistors		
R1	1.91K Ω , 1%, .25W	14-5115
R2	243 Ω , 1%, .25W	14-5105
R3	500 Ω , Pot., 10%, .75W	17-5103
R4	715 Ω , 1%, .25W	14-5127
R5	243 Ω , 1%, .25W	14-5105
R6	200 Ω , Pot., 10%, .75W	17-5105
Diodes		
CR1-CR8	3A, 100V	74-5100
Integrated Circuits		
U1-U2	LM350K	64-0350K
Transformers		
T1	50-400 Hz	83-5103

Table 10.4. OPE-2013 Parts List

Schematic Designation	Description	PTS P/N
C1	1 μ F, 50V, +/- 20%	29-5101
C2	0.1 μ F, 50V, +/- 10%	29-5100
C3	6.8 μ F, 25V	30-5101
C4	50nF, 80/20%, 50V, Z5V	23-0503
C5	NOT USED	
C6	50nF, 80/20%, 50V, Z5V	23-0503
C7	10nF, 80/20%, 50V, Z5V	23-0103
C8	10nF, 80/20%, 50V, Z5V	23-0103
C9	10nF, 80/20%, 50V, Z5V	23-0103
C10	10nF, 80/20%, 50V, Z5V	23-0103
C11	10nF, 80/20%, 50V, Z5V	23-0103
C12	10nF, 80/20%, 50V, Z5V	23-0103
C13	10nF, 80/20%, 50V, Z5V	23-0103
Resistors		
N1 (R1-R8)	68 Ω , Passive Network	66-5006
N1 (R9-R16)	68 Ω , Passive Network	66-5006
N1 (R17-R24)	68 Ω , Passive Network	66-5006
R25	68 Ω , 5%, 1/8W	09-0680
R26	68 Ω , 5%, 1/8W	09-0680
R27	4.7k Ω , 5%, 1/8W	09-0472
R28	4.7k Ω , 5%, 1/8W	09-0472
R29	2.2 Ω , 5%, 1/4W	11-1220
R30	2.2 Ω , 5%, 1/4W	11-1220
R31	4.7k Ω , 5%, 1/8W	09-0472
Integrated Circuits		
U1-U7	HCPL2630	62-5101
U8	X24022P	67-5118
U9	74ACT14	61-5111
U10	TIBPAL20L8A	67-5120

Table 10.4. OPE-2013 Parts List

Schematic Designation	Description	PTS P/N
Connectors		
J1	50 pos. conn. (series 57 compatible)	78-1000
J2	50 pos. conn. (optional)	78-1000
P1	53 pin header strip from 2 @ 26 pin	79-1003
P2	4 pin header strip from 1 @ 26 pin	79-1003

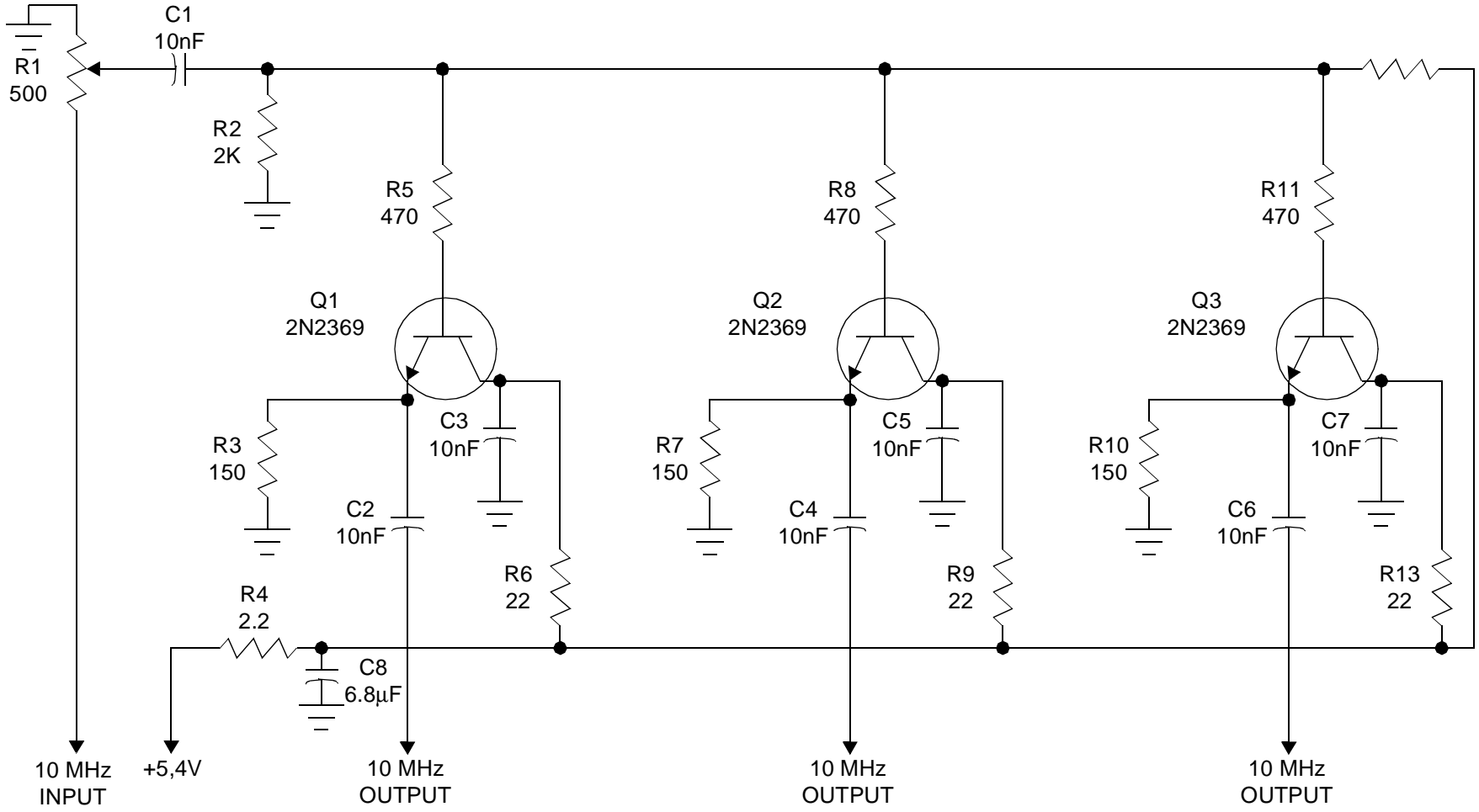

Figure 10.4. MT-2015 Schematic

Table 10.5. MT-2015 Parts List

Schematic Designation	Description	PTS P/N
Capacitors		
C1	10nF, 80/20%, 50V, Z5V	23-0103
C2	10nF, 80/20%, 50V, Z5V	23-0103
C3	10nF, 80/20%, 50V, Z5V	23-0103
C4	10nF, 80/20%, 50V, Z5V	23-0103
C5	10nF, 80/20%, 50V, Z5V	23-0103
C6	10nF, 80/20%, 50V, Z5V	23-0103
C7	10nF, 80/20%, 50V, Z5V	23-0103
C8	6.8 μ F, 25V	30-5101
Resistors		
R1	500 Ω , Pot., 10%, .50W	16-5102
R2	2K Ω , 5%, .25W	11-0202
R3	150 Ω , 5%, .25W	11-0151
R4	2.2 Ω , 5%, .25W	11-1220
R5	470 Ω , 5%, .25W	11-0471
R6	22 Ω , 5%, .25W	11-0220
R7	150 Ω , 5%, .25W	11-0151
R8	470 Ω , 5%, .25W	11-0471
R9	22 Ω , 5%, .25W	11-0220
R10	150 Ω , 5%, .25W	11-0151
R11	470 Ω , 5%, .25W	11-0471
R12	680 Ω , 5%, .25W	110681
R13	22 Ω , 5%, .25W	11-0220
Transistors		
Q1-Q3	2N2369	40-2369

Figures

1 Introduction	5
2 Specifications	7
3 Installation	11
Figure 3.1. Cabinet Dimensions	12
4 Performance/Incoming Inspection Testing	15
5 Operation	19
Figure 5.1. Rear Panel	20
6 Principle of Operation	23
Figure 6.1. PTS DL620 Block Diagram	24
Figure 6.2. PTS DL620 Module and Test Point Locations	27
7 Service	29
8 Calibration	33
9 Mainframe Components	35
10 Schematics	37
Figure 10.1. View of Connector on PTS Equipment	37
Figure 10.2. PS-1053 Schematic	40
Figure 10.3. OPE-2013 Schematic	42
Figure 10.4. MT-2015 Schematic	45

Tables

1	<i>Introduction</i>	5
2	<i>Specifications</i>	7
3	<i>Installation</i>	11
4	<i>Performance/Incoming Inspection Testing</i>	15
5	<i>Operation</i>	19
6	<i>Principle of Operation</i>	23
7	<i>Service</i>	29
8	<i>Calibration</i>	33
9	<i>Mainframe Components</i>	35
10	<i>Schematics</i>	37
Table 10.1.	PTS DL620 Channel F1 and F2	37
Table 10.2.	System Troubleshooting	38
Table 10.3.	PS-1053 Parts List	41
Table 10.4.	OPE-2013 Parts List	43
Table 10.5.	MT-2015 Parts List	46

