

AQR

**AQR Mainframe
Technical Manual**

Version 005

SPECTROSPIN

The information in this manual may be altered without notice.

SPECTROSPIN accepts no responsibility for actions taken as a result of use of this manual. SPECTROSPIN accepts no liability for any mistakes contained in the manual, leading to coincidental damage, whether during installation or operation of the instrument. Unauthorised reproduction of manual contents, without written permission from the publishers, or translation into another language, either in full or in part, is forbidden.

This manual was written by

Werner Heiz

© January 1994 - Spectrospin AG, CH-8117 Faellanden

Updated for BASH 2.0 by U. Roos - December 1996

P/N: Z31191

DWG-Nr: 862 005

1	AQR-General Description	3
1.1	Introduction	3
1.2	Basic of Operation	3
1.3	Troubleshooting	3
2	Chassis and Bus	5
2.1	Introduction	5
2.2	User-Bus	6
2.3	I2C Addresses	7
2.4	Technical Data	8
3	Power Supply	9
3.1	Introduction	9
3.2	Installation	10
3.3	Overview Power-Supply-System	11
3.4	Overview Control Signals	12
3.5	Ground Concept	13
3.6	Power-Supply-Board (PSB)	14
3.7	Voltages and Currents of the PSB1	15
3.8	Voltages and Currents of the PSB2	16
3.9	Voltages and Currents of the PSB3	17
3.10	Power-Supply-Distribution (PSD)	18
3.11	Transformer	19
3.12	Wiring from PSD1 to SE451 and HPPR	20
3.13	Troubleshooting	21
4	Appendix	23
4.1	Introduction	23
4.2	Scheme Wiring	24
4.3	Scheme Power-Supply-Board	26
4.4	Assembly map Power-Supply-Board (PSB1)	31
4.5	Assembly map Power-Supply-Board (PSB2)	32
4.6	Assembly map Power-Supply-Board (PSB3)	33
4.7	List of parts Power-Supply-Board (PSB1)	34
4.8	List of parts Power-Supply-Board (PSB2)	41
4.9	List of parts Power-Supply-Board (PSB3)	48
4.10	Scheme Power-Supply-Adapter (PSD1)	54
4.11	Assembly map Power-Supply-Distribution (PSD1)	56
4.12	Scheme User-Bus	58
4.13	Assembly map User-Bus	76
4.14	Layout map User-Bus	79
	List of Index	85
	List of Figures	87

List of Tables	89
----------------------	----

Introduction

1.1

This manual describes the mainframe of the AQR (**A**cquisition **R**ack).

The following hardware is necessary:

1. One chassis wired (toroidal transformer, fan).
2. One **P**ower-**S**upply-**B**oard (PSB1).
3. One **P**ower-**S**upply-**B**oard (PSB2).
4. One **P**ower-**S**upply-**B**oard (PSB3).
5. One **P**ower-**S**upply-**D**istribution (PSD1).
6. One User-Bus.

Basic of Operation

1.2

Current surge: Toroidal transformers show a considerably higher switching-on current surge than conventional EJ transformers. The value of the current is dependent on the instant of switching-ON as well as on the instant of switching-OFF (due to remanent magnetism). The surge current is limited with a NTC-Resistor (negative temperature coefficient resistor). This works only if the NTC is cooled down before switching on. Should this not be the case the primary fuse will be damaged.

Therefore: Avoid repeatedly switching the unit ON / OFF.

Troubleshooting

1.3

Almost all supply voltages can be checked via the corresponding LED's on the backside of the AQR unit. For detail information see Power-Supply-Board on page 14.

The main fuses are in the line module located. Technical data see on page 8.

The AQR is a special rack with 13 slots on the front side and 4 slots on the backside. All boards except the User-Bus are extended Eurocard-Boards. A complete equipped AQR holds from the front side 12 boards (10 * 7TE, 1 * 4TE, 1 * 6TE). The backside houses the power supply which includes 3 power supply boards (3 * 12TE) and the transformer. The power supply distribution (1 * 4TE) is also on the backside located. Between the front side and the backside is a User-Bus.

Figure 1: Front view of a complete equipped AQR

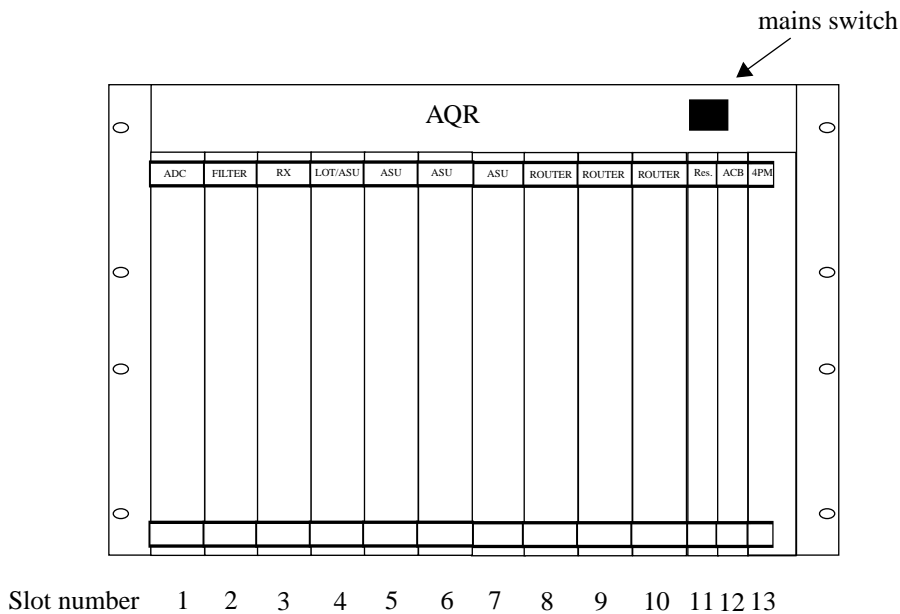
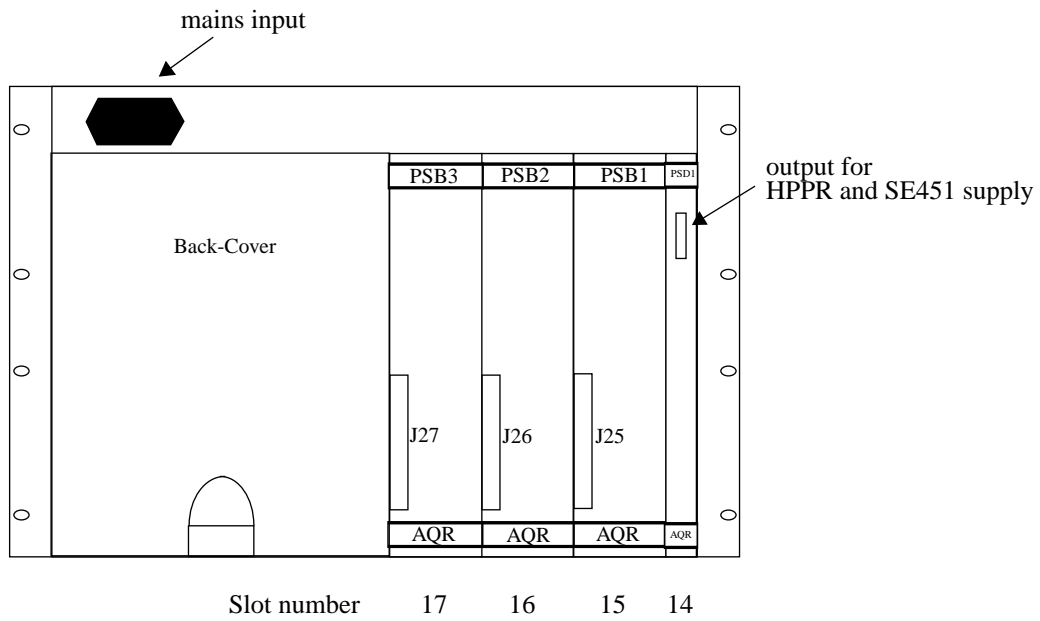

Figure 2: Back view of the AQR



The back view shows the power supply unit, housing of the power supply boards PSB1, PSB2, PSB3 and PSD1. Behind the back-cover is the transformer located. For more information about the power supply see Chapter 3.

User-Bus

2.2

Figure 3: User-Bus in the AQR (Front view)

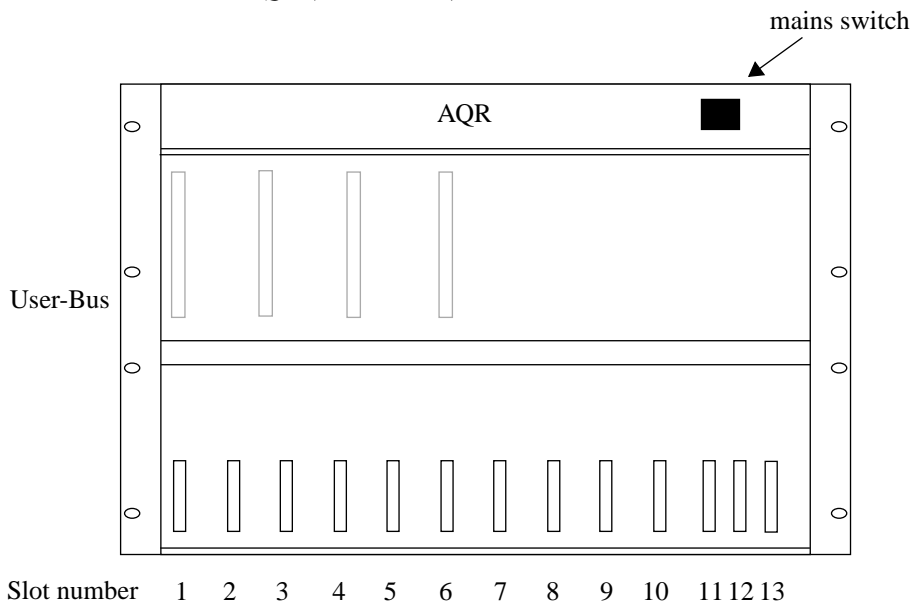

The User-Bus is designed to route all specific signals and power supplies to the specific boards. It contains the frame ground point of the AQR. About the ground concept see page 13.

The I2C-bus is split in two parts see Overview Control Signals page 12. Part one includes: Slot 1 / 2 / 3. Part two includes: Slot 4 / 5 / 6 / 7 / 8 / 9 / 10 / 11 / 12 / 13. Every slot has his unique I2C address range see table 1. See also scheme User-Bus page 55 - 67.

Table 1. I2C Address configuration

Slot	1	2	3	4	5	6	7	8	9	10	11	12	13
Address range	70-7F	60-6F	50-5F	70-7F	60-6F	50-5F	40-4F	30-3F	20-2F	10-1F	00-0F		

Table 2. Technical Data of the AQR Chassis:

AQR Chassis				
General	Height (7TE)	310,3	mm	Only the chassis without any boards or connectors in it.
	Width	482,7	mm	
	Depth	482	mm	
	Weight	44	kg	Including: Chassis wired (fan, transformer, PSB1, PSB2, PSB3, 1*PSD1, User-Bus), 1*ADC, 1*RX, 1*FILTER, 1*LOT/ASU, 3*ASU, 3*ROUTER, 1*ACB, 1*4PM
Boards except User-Bus	Height	233,4	mm	
	Length	220	mm	
User-Bus	Height	263	mm	
	Width	426,7	mm	

Table 3. Technical Data of the Line Module:

Linie Module			
Main Fuse	5	A	time lag
Power	250	V	50 / 60Hz

The Power-Supply of the AQR is located at the rear of the AQR Chassis. This consists essentially of three Power-Supply-Boards PSB1, PSB2 and PSB3. The Power-Supply-Distribution (PSD1) is just an adapter for the HPPR power supply. The transformer is fixed behind the back-cover in a separate box. Wiring has been reduced to a minimum.

The mains supply may be selected as 220VAC, 230VAC, 240VAC and is supplied via the mains selector (see page 10).

The power supply unit generates 20 electrically separated voltages for the various boards or units. The voltage distribution isn't done by a wiretree, it's done on the layout of the User-Bus.

Ground concept: see page 13.

Figure 4: Back view of the AQR

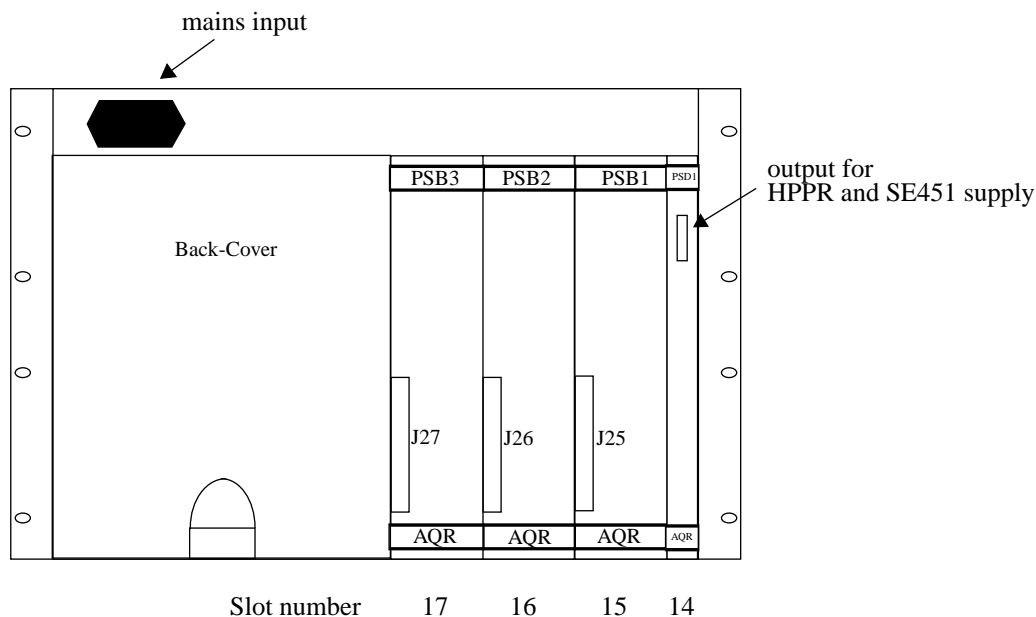

Important: Before you turn ON the Power-Switch check the mains selector

Remove the Back-Cover (4 screws) and you will see the mains selector (see also figure 5).

Before you turn ON the Power-Switch check the mains selector. The transformer has 6 different coil ends on the primary side 0V / 220V / 230V / 240V and 2 static shield ends. You must be sure that the mains input is connected on the right primary coil end.

Figure 5: The mains selector

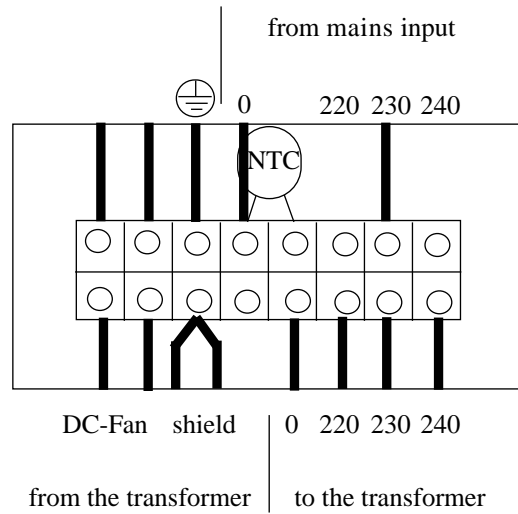

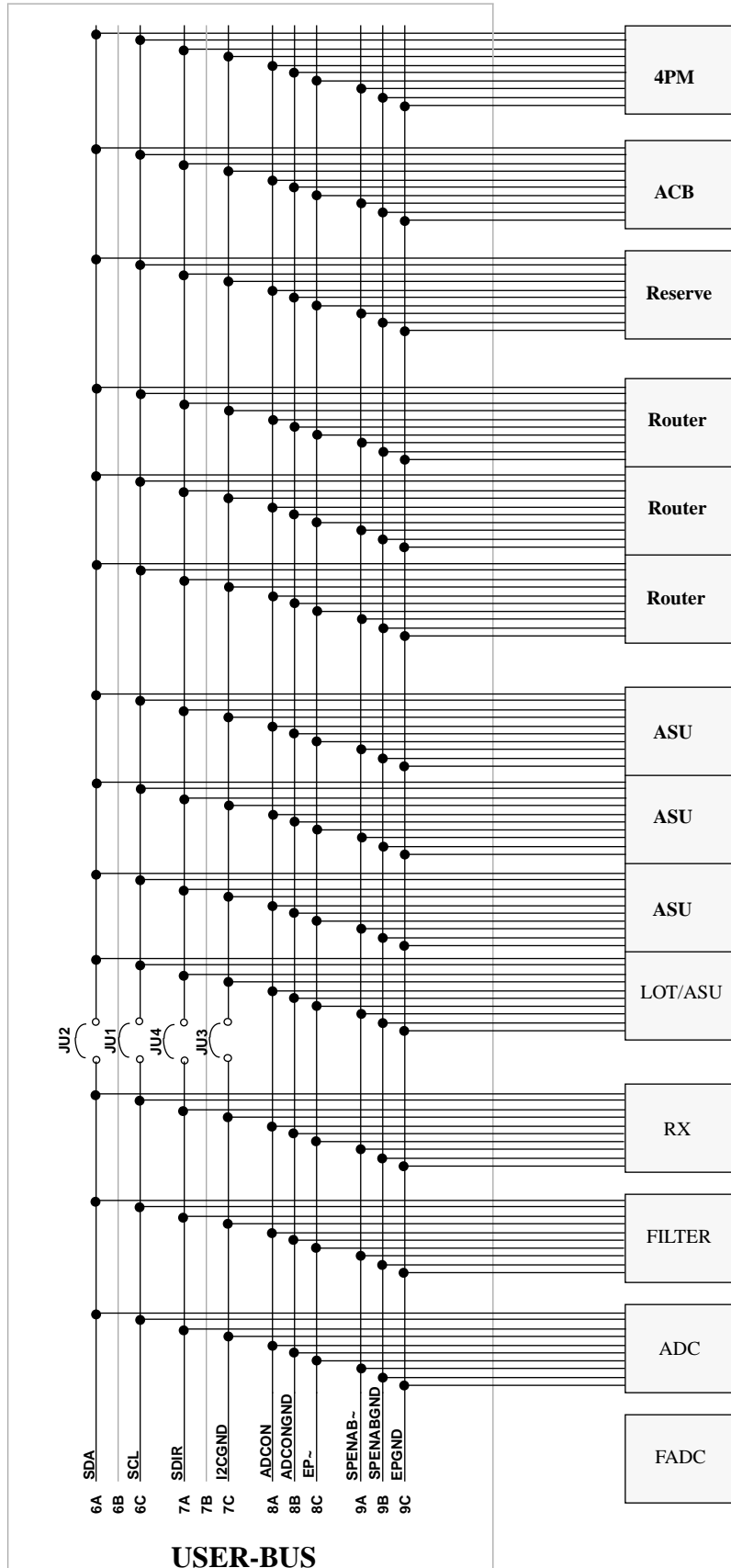

Every unit (ADC,FILTER,RX,FADC / LOT-ASU,ASU,ASU,ASU / ROUTER,ROUTER,ROUTER / ACB / 4PM) has its own power supply. The voltage distribution isn't done by a wiretree, it's done on a User-Bus. IF a board (for example ADC, FILTER etc.) needs digital and analog voltages so it will be the best way to connect the digital- and analog ground together on the board.

Option: There is a possibility on the User-Bus that you can connect every units GND to the starlike **SGND** (see Figure 6 or Overview Power-Supply-System on Page 11.This connection can be done by a resistor or an inductance or just a wire. There is also the possibility to do a connection from **SGND** to the chassis via a screw by a resistor or an inductance or just a wire.

Figure 6: Starlike ground point

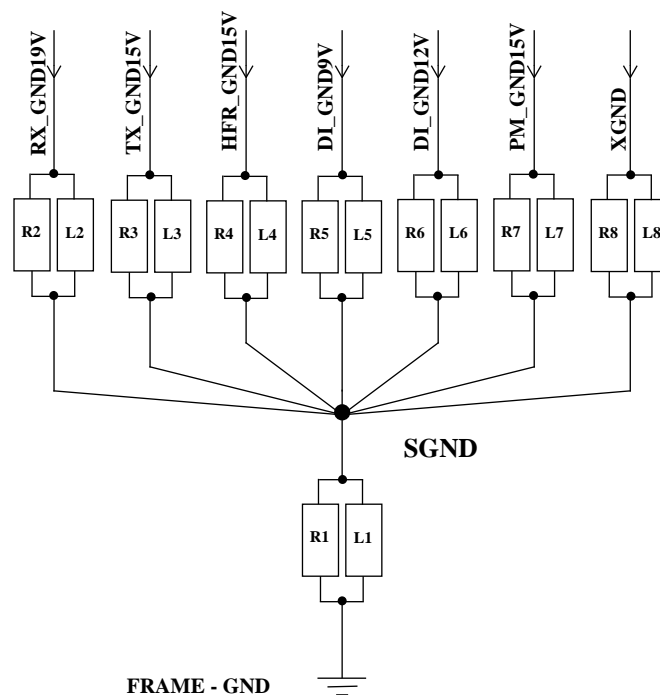

NOTE: Every GND connection can be done by a resistor or a inductance or a wire (there are two shapes on the board).

Ground-Ground-Connection

3.5.1

There is also an possibility to connect the different ANALOG- and DIGITAL - GND together. This can be done with R9, R10, R11, R12, R13, R14, R15, R16 (0 Ohm resistors) on the User-Bus.

The **Power-Supply-Board (PSB)** is realised with the board (Z3P 2966) which can be assembled in different variants. At the AQR we need 3 different variants of power supply boards. Scheme, assembly map and list of parts see appendix chapter 4.

The voltages can be checked via the corresponding LED's on the frontpanel of the power supply boards. Above and below every LED is a test point. **The test point above the LED is always the higher potential of the corresponding voltage.** How do check the power supply see troubleshooting page 21.

Figure 7: Frontpanel of a PSB1, PSB2 and PSB3

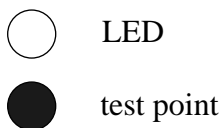
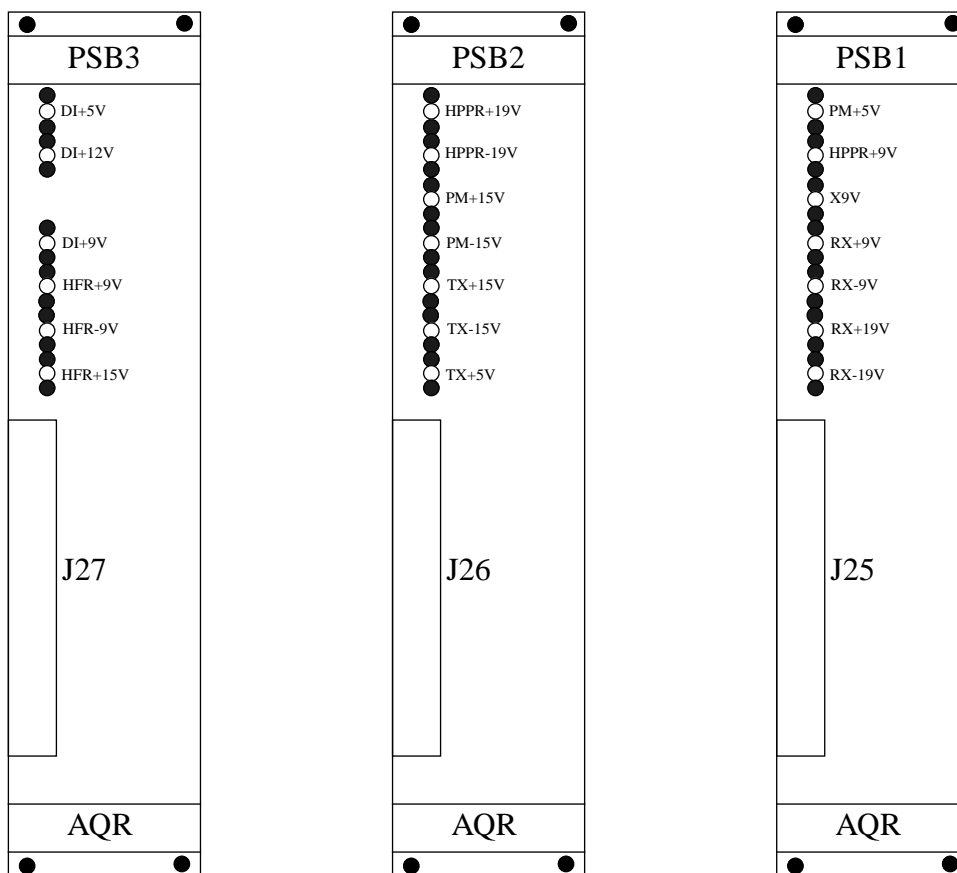

Voltages and Currents of the PSB1

Table 4. Rated Voltages and Currents of PSB1

output J1	name	voltage	current	AC-noise[mVpp]
1 a/b/c 2 a/b/c	PM+5V	+5V+/-0,15V	1,2A	20mV
3a/b/c 4a/b/c	PM_GND5V	GND		
6a/b/c 7a/b/c	HPPR+9V	+9V+/-0,3V	1A	20mV
8a/b/c 9a/b/c	HPPR_GND9V	GND		
11a/b/c 12a/b/c	X9V	12V+/-0,6V	1A	1500mV not regulated
13a/b/c 14a/b/c	XGND	GND		
16a/b/c 17a/b/c	RX+9V	+9V+/-0,3V	¹⁾ 2,2A	20mV
18a/b/c 19a/b/c	RX_GND9V	GND		
21a/b/c 22a/b/c	RX_GND9V	GND		
23a/b/c 24a/b/c	RX-9V	-9V+/-0,3V	1A	20mV
25a/b/c 26a/b/c	RX+19V	+19V+/-0,7V	4,5A	20mV
27a/b/c 28a/b/c	RX_GND19V	GND		
29a/b/c 30a/b/c	RX_GND19V	GND		
31a/b/c 32a/b/c	RX-19V	-19V+/-0,7V	¹⁾ 2,2A	20mV

¹⁾ for ECL01 and higher

Table 5. Rated Voltages and Currents of PSB2

output J1	name	voltage	current	AC-noise[mVpp]
1 a/b/c 2 a/b/c	HPPR+19V	+19V+/-0,7V	3,3A	20mV
3a/b/c 4a/b/c	HPPR_GND19V	GND		
6a/b/c 7a/b/c	HPPR_GND19V	GND		
8a/b/c 9a/b/c	HPPR-19V	-19V+/-0,7V	800mA	20mV
11a/b/c 12a/b/c	PM+15V	+15V+/-0,6V	1,2A	20mV
13a/b/c 14a/b/c	PM_GND15V	GND		
16a/b/c 17a/b/c	PM_GND15V	GND		
18a/b/c 19a/b/c	PM-15V	-15V+/-0,6V	1,2A	20mV
21a/b/c 22a/b/c	TX+15V	+15V+/-0,6V	¹⁾ 4A	20mV
23a/b/c 24a/b/c	TX_GND15V	GND		
25a/b/c 26a/b/c	TX_GND15V	GND		
27a/b/c 28a/b/c	TX-15V	-15V+/-0,6V	1,8A	20mV
29a/b/c 30a/b/c	TX+5V	+5V+/-0,15V	700mA	20mV
31a/b/c 32a/b/c	TX_GND5V	GND		

¹⁾ for ECL01 and higher

Voltages and Currents of the PSB3

Table 6. Rated Voltages and Currents of PSB3

Output J1	name	voltage	current	AC-noise[mVpp]
1 a/b/c 2 a/b/c	DI+5V	+5V+/-0,15V	1,2A	20mV
3a/b/c 4a/b/c	DI_GND5V	GND		
6a/b/c 7a/b/c	DI+12V	+12V+/-0,4V	500mA	20mV
8a/b/c 9a/b/c	DI_GND12V	GND		
11a/b/c 12a/b/c	(DI-12V) isn't mounted		500mA	
13a/b/c 14a/b/c				
16a/b/c 17a/b/c	DI+9V	+9V+/-0,3V	1,2A	20mV
18a/b/c 19a/b/c	DI_GND9V	GND		
21a/b/c 22a/b/c	HFR+9V	+9V+/-0,3V	1,5A	20mV
23a/b/c 24a/b/c	HFR_GND9V	GND		
25a/b/c 26a/b/c	HFR_GND9V	GND		
27a/b/c 28a/b/c	HFR-9V	-9V+/-0,3V	1,5A	20mV
29a/b/c 30a/b/c	HFR+15V	+15V+/-0,6V	3A	20mV
31a/b/c 32a/b/c	HFR_GND15V	GND		

The **Power-Supply-Distribution (PSD)** is realised with the board (Z4P 2974) which can be assembled in 2 different variants. The PSD1 is an adapter to get the power supplies for the HPPR (Cannon-Connector on the frontpanel). The pin assignment for this connector J3 see table 8 on page 20.

Scheme, assembly map and list of parts see appendix chapter 4.

Figure 8: Frontpanel of PSD1



Transformer

3.11

Transformer-Connector

3.11.1

J2 is the input connector (male) on the power supply board.

J25 is the transformer connector (female) which is to plug in to PSB1.

J26 is the transformer connector (female) which is to plug in to PSB2.

J27 is the transformer connector (female) which is to plug in to PSB3.

Table 7. Pin assignment transformer-/ PSB-Connector

J2 / PIN-Nr.	J25/J2 (PSB1) signal-name (voltage value)	J26/J2 (PSB2) signal-name (voltage value)	J27/J2 (PSB3) signal-name (voltage value)
4	RX+19V / B	TX-15V / B	
6	RX-19V / B	TX+5V / B	HFR+15V / B
8	RX-19V / E		HFR+15V / E
10	RX+19V / E	TX-15V / E	HFR-9V / E
12		TX+5V / E	HFR-9V / B
14	RX+9V / B	PM-15V / B	DI+9V / B
16	RX-9V / E	TX+15V / E	HFR+9V / E
18	RX+9V / E	PM-15V / E	DI+9V / E
20	RX-9V / B	TX+15V / B	HFR+9V / B
22	X9V / E	PM+15V / E	DI-12V / E
24	HPPR+9V / E	HPPR-19V / E	DI+12V / E
26	X9V / B	PM+15V / B	DI-12V / B
28	HPPR+9V / B	HPPR-19V / B	DI+12V / B
30	PM+5V / E	HPPR+19V / E	DI+5V / E
32	PM+5V / B	HPPR+19V / B	DI+5V / B

B--> means coil-begin

E --> means coil-end

The power supply of the external units HPPR and SE451 are also integrated in the AQR power supply. There is enough power for 10 HPPR-module and 2 SE451 units.
J3 is a CANNON (female) connector on the PSD1 board in the AQR.

Table 8. Connector pin assignment PSD1 - -> HPPR / SE451

PSD1 / J3	signal-name	voltage	SE451 Bourndy	HPPR J0
1				
14 / 2				
15 / 3	RX_N19V	-19V	J	
16 / 4	RX_GND19V	0V	HH	
17 / 5	RX_P19V	+19V	K	
18 / 6	RX_GND9V	0V	HH	
19 / 7	RX_P9V	+9V	Y	
20	XGND	0V		V
8	X9V	+12V (unregulated)		U
21 / 9	HPPR_GND9V	0V		M
22 / 10	HPPR_P9V	+9V		N
23 / 11	HPPR_N19V	-19V		L
24 / 12	HPPR_GND19V	0V		H,B
25 / 13	HPPR_P19V	+19V		A,C

If anything does not work at the AQR check the power supply first.

1. Check the power supplies LED on the back side.
2. IS no LED lighting check the primary fuses in the line module unit.
3. Check if the transformer connector (J25, J26 and J27) is plug in.
4. Check the secondary fuses, they are on the PSB boards located.
5. Above and below every LED is a test point to check the corresponding voltage by a multimeter or an oscilloscope. **The test point above the LED is always the higher potential of the corresponding voltage.**
6. Is a power supply after this checks still not working, check the no-load output voltage. How to do it: Turn off the AQR (power off) plug out the transformer connector (J25 or J26 or J27), plug out the corresponding PSB (PSB1 or PSB2 or PSB3). Plug in the transformer connector again and turn on the AQR (power on). Check again point 1 and point 5.
7. Are all power supplies ok, you should also check the further regulators on the ADC, FLT, RX, LOT/ASU, ASU, ROUTER, ACB and 4PM boards. For more information about a specific voltage of one of this boards see the corresponding manual.
8. ***Attention:*** If you check the ac-ripple at the test points on the PSB boards with an oscilloscope, you will see additional spikes. The reason for this additional spikes is: There are two sense wires from output of the regulator via a 1kohm resistor to the test point and so the oscilloscope has no hard ground.

On the following pages you will find: Schemes, Assembly maps and the List of parts.

1. Scheme Wiring.
2. Scheme Power-Supply-Board (PSB).
3. Assembly map PSB1,PSB2,PSB3.
4. List of parts PSB1,PSB2,PSB3.
5. Scheme Power-Supply-Distribution (PSD1)
6. Assembly map PSD1.
7. Scheme User-Bus
8. Assembly User-Bus
9. Layout map User-Bus

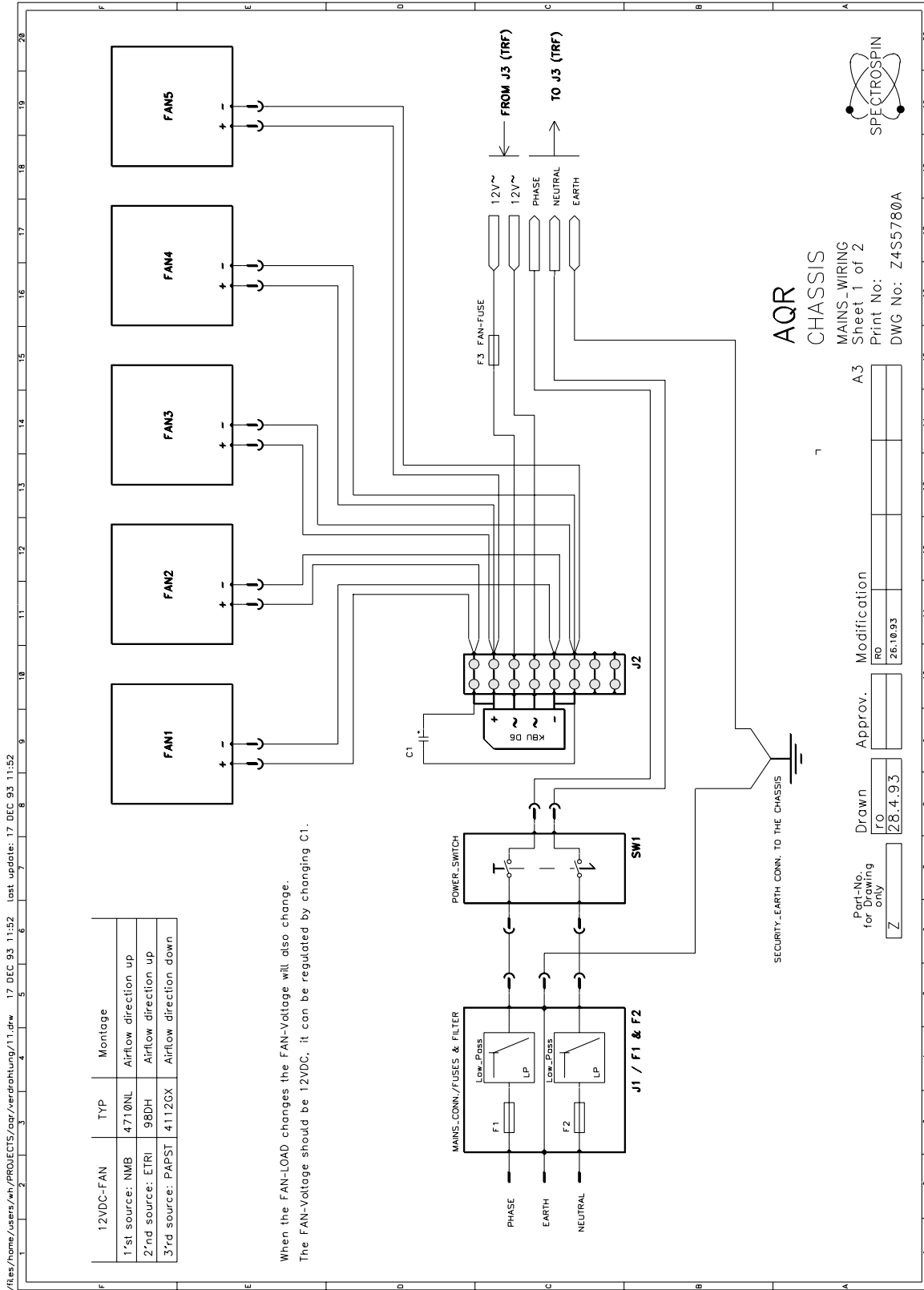

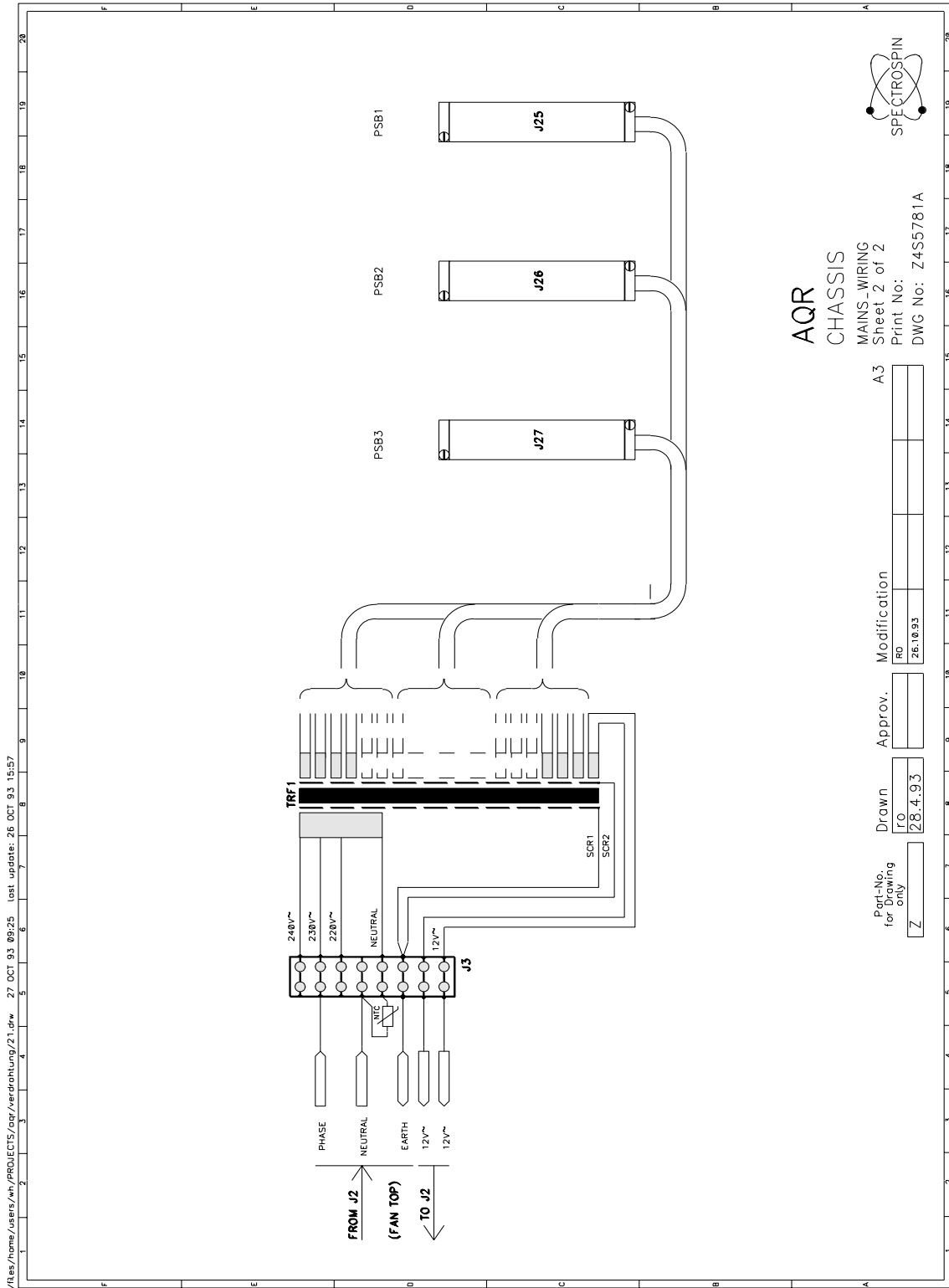

AQR
CHASSIS
 MAINS_WIRING
 Sheet 2 of 2
 Print No:
 DWG No: Z4S5781A



Pgt.-No. for Drawing only	Drawn	Approv.	Modification	A3
Z	28.4.93		RD 26.10.93	

/files/home/users/wh/AQR/uni_modul/1.drw 22 JUN 93 08:37 last update: 18 JUN 93 09:57

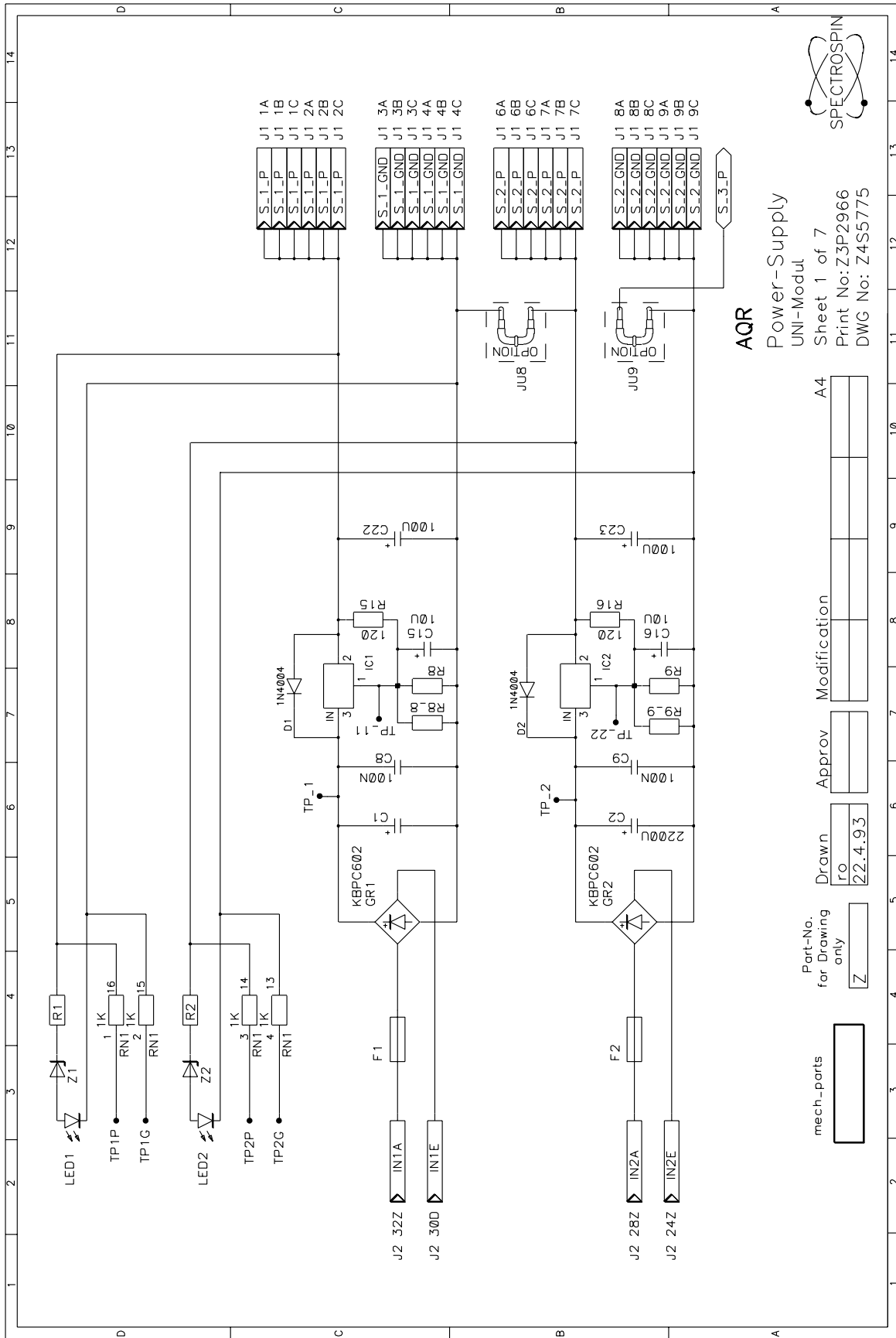

Part-No.		Drawn	Approv	Modification
for Drawing only	Z	ro		
		22.4.93		

/files/home/users/wh/AQR/uni_modul/2.drw 22 JUN 93 08:37 last update: 18 JUN 93 13:01

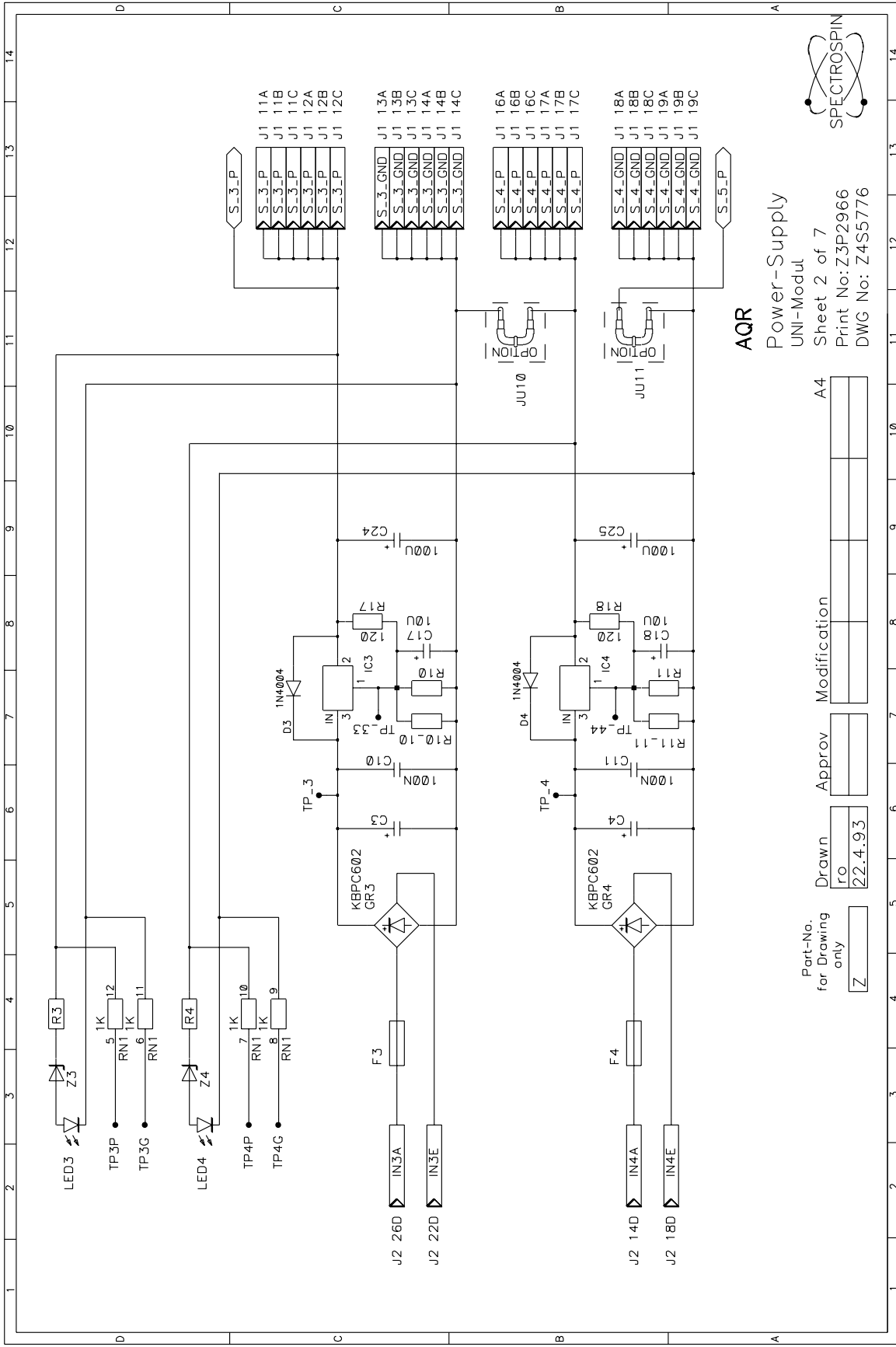

Part-No. for Drawing only	Drawn ro	Approv	Modification
Z	22.4.93		

/files/home/users/wh/AQR/uni_modul/3.drw 22 JUN 93 08:38 last update: 18 JUN 93 11:01

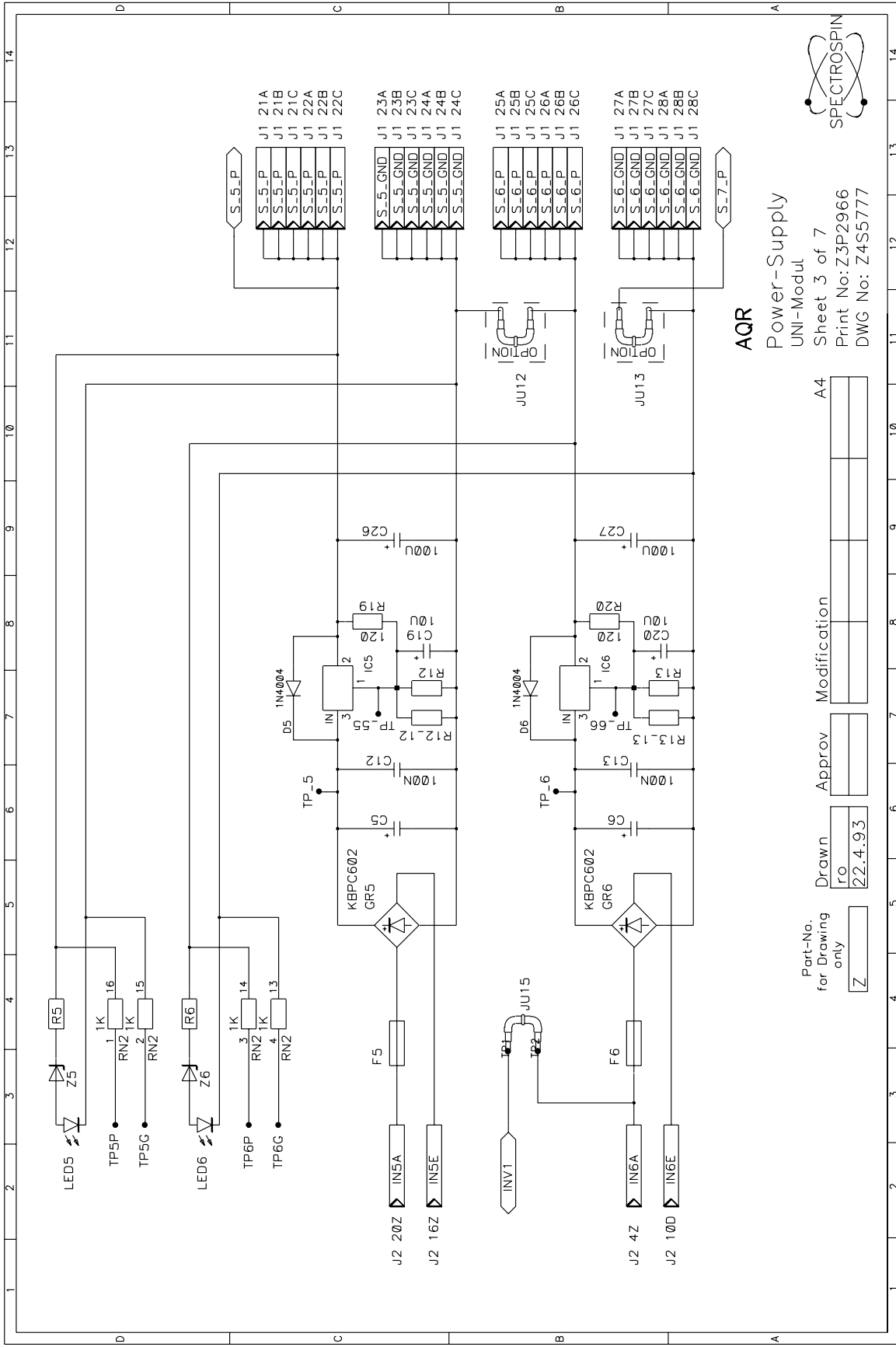

AQR

Power-Supply
UNI-Modul
Sheet 3 of 7
Print No: Z3P2966
DWG No: Z4S5777



Part-No. for Drawing only	Drawn ro	Approv	Modification
Z	22.4.93		

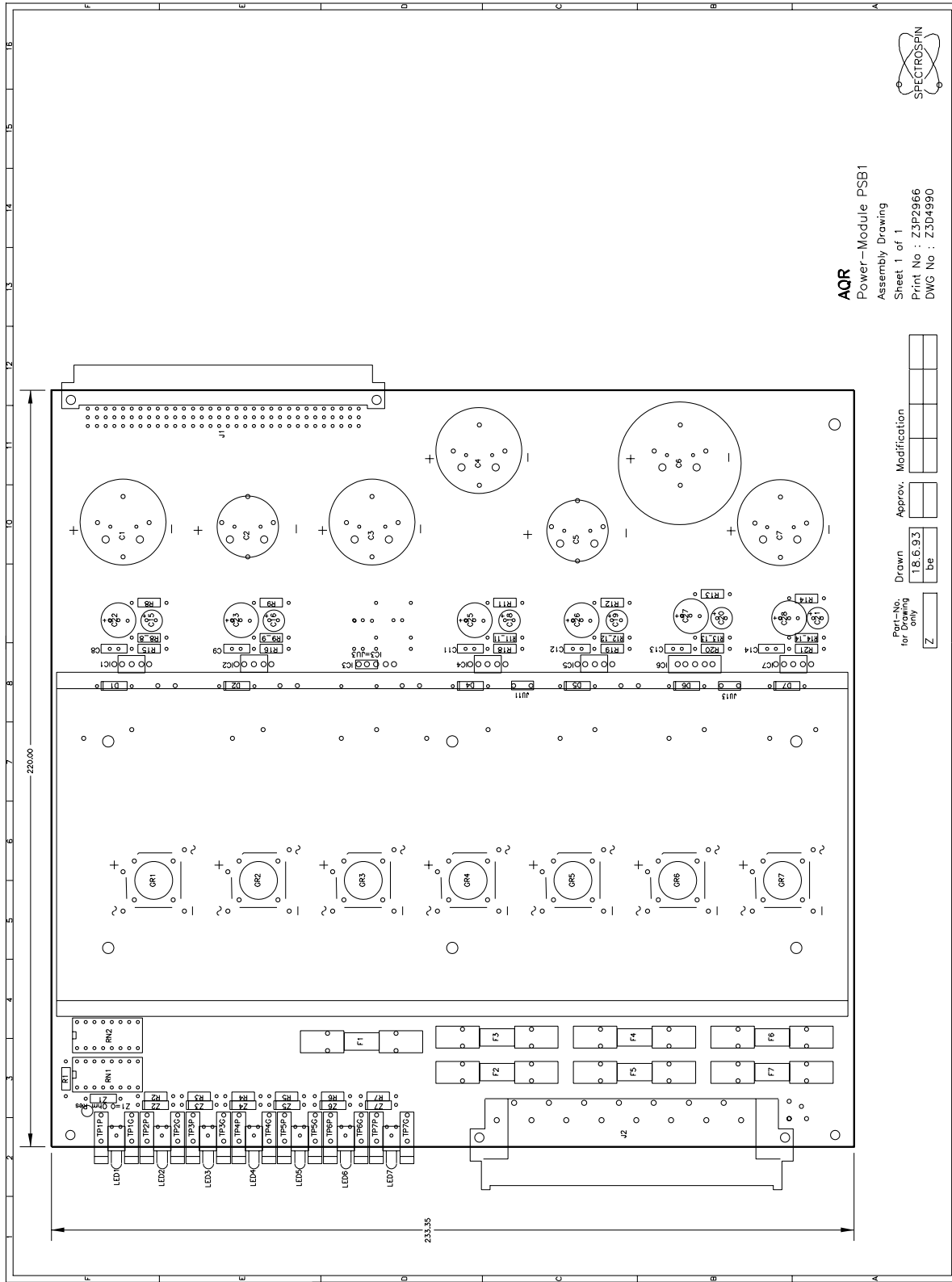

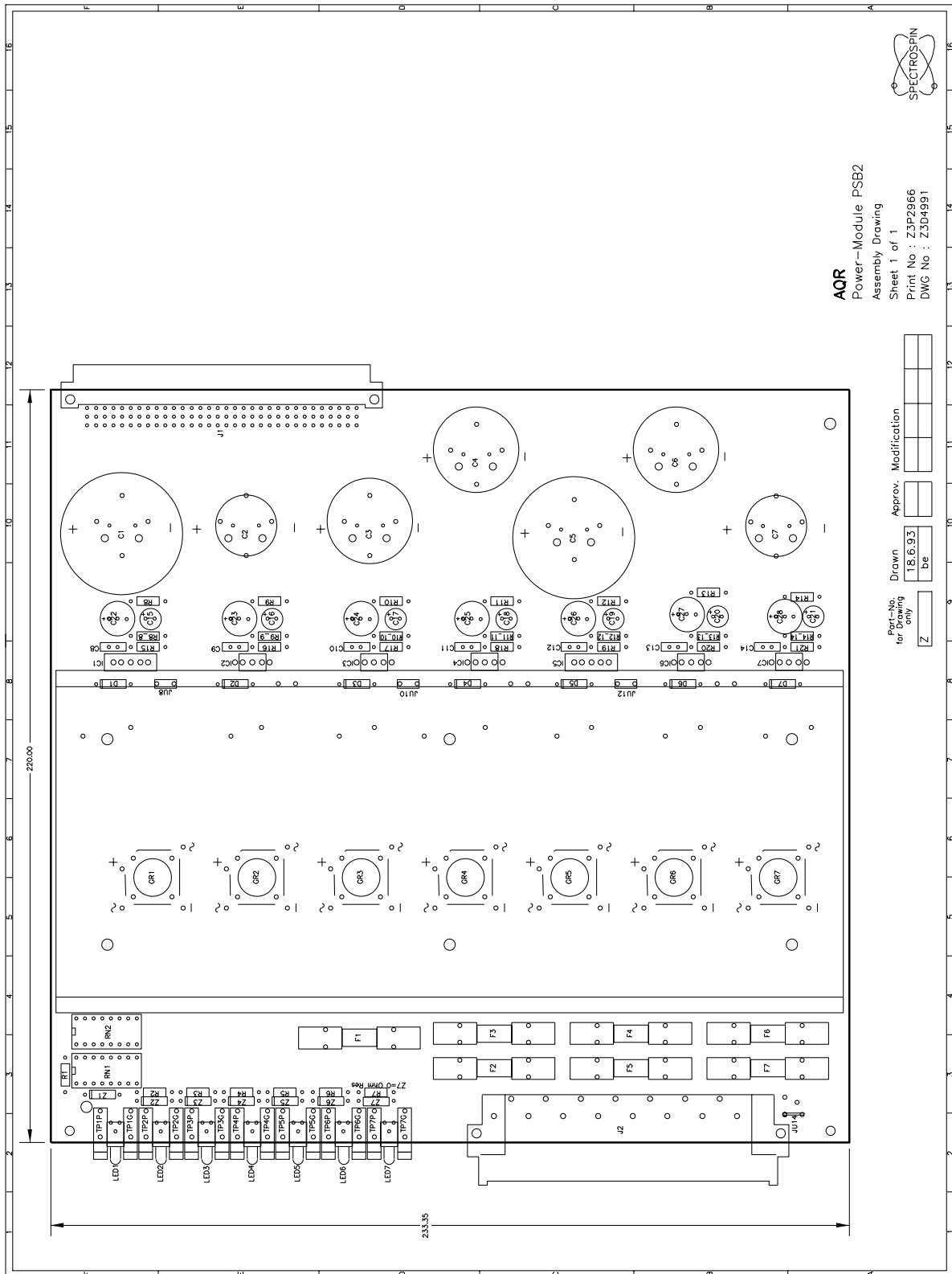

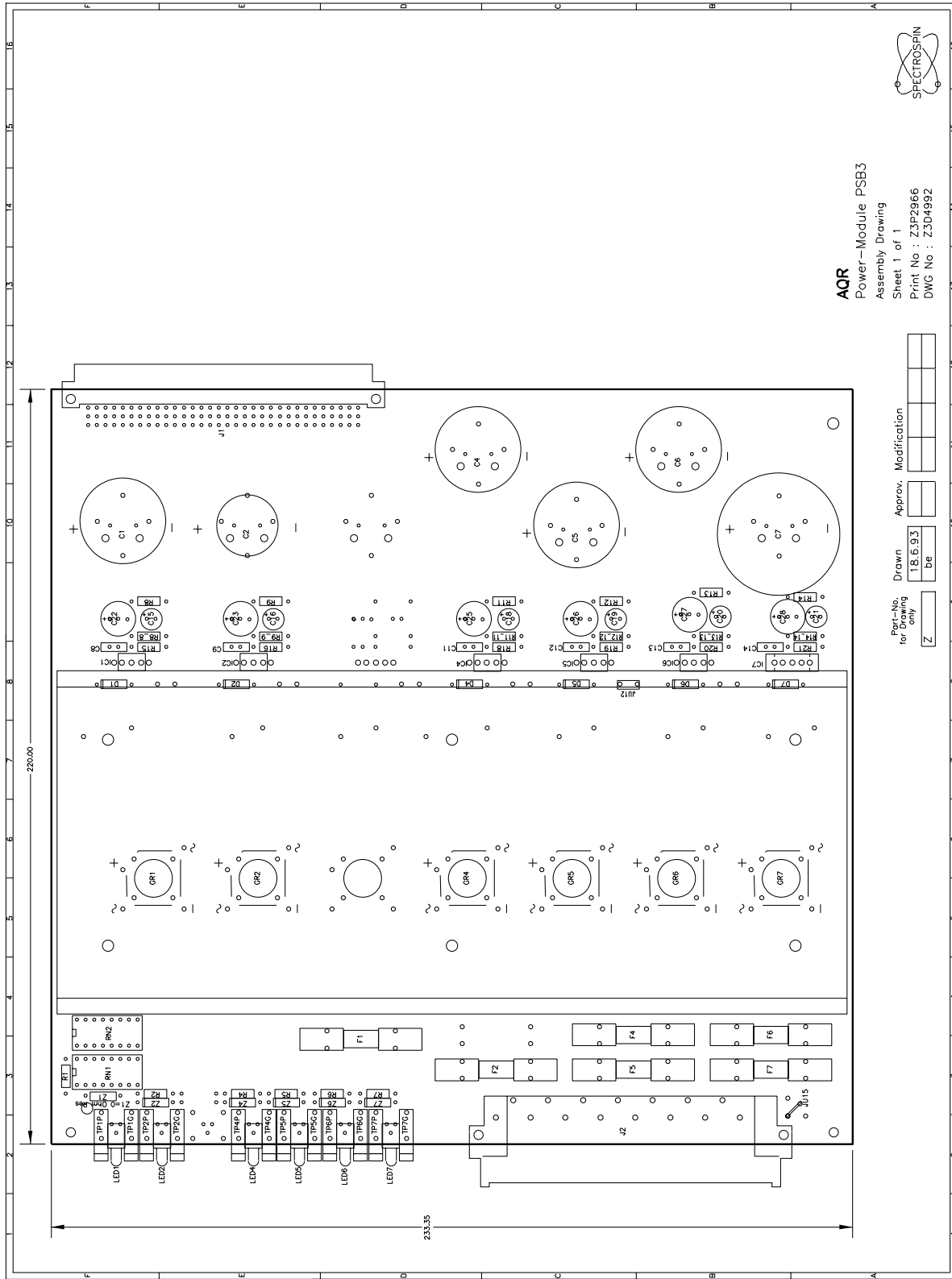

```

# Company : SPECTROSPIN AG
# Product : AQR
# Print-Name : Power-Supply Print-Number: Z3P2966
# Sheet-Name : UNI-Modul DWG-Number : Z4S5775
# Sheet-Name : UNI-Modul DWG-Number : Z4S5776
# Sheet-Name : UNI-Modul DWG-Number : Z4S5777
# Sheet-Name : UNI-Modul DWG-Number : Z4S5778
# Sheet-Name : VARIANT DWG-Number : Z3S5811A
# Sheet-Name : Mechanical Parts DWG-Number : Z3S5809
# Sheet-Name : Mechanical Parts DWG-Number : Z3S5810A
# Date-Time : 30.Jul.93 17:14:41 Account : be
#
# Variant : PSB1
#
#.....
#ANZ :PHY_LOC :CAT_NM :PART_NM :VALUE :SHAPE :NOTE :
#.....:
# :Resistors
:R1 :20817 :RES :270 :R04010A : :
:R2 :8762 :RES :180 :R04010A : :
:R3 :8762 :RES :180 :R04010A : :
:R4 :8762 :RES :180 :R04010A : :
:R5 :8762 :RES :180 :R04010A : :
:R6 :8762 :RES :180 :R04010A : :
:R7 :8762 :RES :180 :R04010A : :
:R8 :20868 :RES :390 :R04010A : :
:R8_8 :20578 :RES :4.7K :R04010A : :
:R9 :4716 :RES :820 :R04010A : :
:R9_9 :3960 :RES :8.2K :R04010A : :
:R11 :4716 :RES :820 :R04010A : :
:R11_11 :3960 :RES :8.2K :R04010A : :
:R12 :4716 :RES :820 :R04010A : :
:R12_12 :3960 :RES :8.2K :R04010A : :
:R13 :20820 :RES :33K :R04010A : :

```



```
#.....:
# :Diodes
:D1 :4326 :1N4004 : :DO41 : :
:D2 :4326 :1N4004 : :DO41 : :
:D4 :4326 :1N4004 : :DO41 : :
:D5 :4326 :1N4004 : :DO41 : :
:D6 :4326 :1N4004 : :DO41 : :
:D7 :4326 :1N4004 : :DO41 : :
#.....:
# :ICs
:IC1 :42146 :LM338T : :TO220_SPC : :
:IC2 :42146 :LM338T : :TO220_SPC : :
:IC3 :20448 :SOLDER_SPRIN: :LOETBUG11 : :
:IC4 :42146 :LM338T : :TO220_SPC : :
:IC5 :42146 :LM338T : :TO220_SPC : :
:IC6 :19161 :LT1083CP : :TO220_SPC : :
:IC7 :42146 :LM338T : :TO220_SPC : :
#.....:
# :Connectors
84 :J1 :6948 :41612A96MC : :41612A96MC : :
15 :J2 :21904 :41612A15MH : :41612A15MH : :
#.....:
# :divers
:F1 :2254 :FUSE :2.0A T :F_6_3X32 : :
:F2 :2253 :FUSE :1.6A T :F_6_3X32 : :
:F3 :2253 :FUSE :1.6A T :F_6_3X32 : :
:F4 :2256 :FUSE :4.0A T :F_6_3X32 : : (for ECL01 and higher)
:F5 :2253 :FUSE :1.6A T :F_6_3X32 : :
:F6 :2259 :FUSE :8A T :F_6_3X32 : :
:F7 :2255 :FUSE :4.0A T :F_6_3X32 : : (for ECL01 and higher)
:GR1 :362 :GRAETZ_SPC :KBPC602 :BR_SPC : :
:GR2 :362 :GRAETZ_SPC :KBPC602 :BR_SPC : :
:GR3 :362 :GRAETZ_SPC :KBPC602 :BR_SPC : :
:GR4 :362 :GRAETZ_SPC :KBPC602 :BR_SPC : :
:GR5 :362 :GRAETZ_SPC :KBPC602 :BR_SPC : :
:GR6 :362 :GRAETZ_SPC :KBPC602 :BR_SPC : :
```

:GR7 :362 :GRAETZ_SPC :KBPC602 :BR_SPC : :
 :JU11 :20448 :SOLDER_SPRIN: :LOTBUG11 :LOETBUEGEL :
 :JU13 :20448 :SOLDER_SPRIN: :LOTBUG11 :LOETBUEGEL :
 :LED1 :21866 :LED :GRUEN :LED3 : :
 :LED2 :21866 :LED :GRUEN :LED3 : :
 :LED3 :21866 :LED :GRUEN :LED3 : :
 :LED4 :21866 :LED :GRUEN :LED3 : :
 :LED5 :21866 :LED :GRUEN :LED3 : :
 :LED6 :21866 :LED :GRUEN :LED3 : :
 :LED7 :21866 :LED :GRUEN :LED3 : :
 :MECH1 :Z12472 :PCB : :Z3P2966 :PRINT :
 :MECH10 :22598 :SUMMENBEFEST: : :SUMMENBEFESTIGUNG:
 : : : : : LINKS :
 :MECH100 :25573 :SCREW_RND :M3x8 : :LINSENSCHRAUBE :
 :MECH101 :25573 :SCREW_RND :M3x8 : :LINSENSCHRAUBE :
 :MECH11 :22599 :SUMMENBEFEST: : :SUMMENBEFESTIGUNG:
 : : : : : RECHTS :
 :MECH12 :Z12153 :HALSSCHRAUBE:M2.5x8.5: :HALSSCHRAUBE :
 :MECH13 :Z12153 :HALSSCHRAUBE:M2.5x8.5: :HALSSCHRAUBE :
 :MECH14 :Z12153 :HALSSCHRAUBE:M2.5x8.5: :HALSSCHRAUBE :
 :MECH15 :Z12153 :HALSSCHRAUBE:M2.5x8.5: :HALSSCHRAUBE :
 :MECH16 :22633 :SICH.HALTER :5x20/6x3: :SICH.HALTER :
 :MECH17 :22633 :SICH.HALTER :5x20/6x3: :SICH.HALTER :
 :MECH18 :22633 :SICH.HALTER :5x20/6x3: :SICH.HALTER :
 :MECH18 :25648 :RIVET_TUBE :2,5X0,3X:RIVET_TUBE :ROHRNIETE :
 :MECH19 :22633 :SICH.HALTER :5x20/6x3: :SICH.HALTER :
 :MECH19 :25648 :RIVET_TUBE :2,5X0,3X:RIVET_TUBE :ROHRNIETE :
 :MECH2 :Z12473 :HEAT_SINK :Z2M7650 :KK100X230 :KUEHLKOERPER :
 :MECH20 :22633 :SICH.HALTER :5x20/6x3: :SICH.HALTER :
 :MECH20 :25689 :RIVET_TUBE :2,5X0,25:RIVET_TUBE :ROHRNIETE :
 :MECH21 :22633 :SICH.HALTER :5x20/6x3: :SICH.HALTER :
 :MECH21 :25689 :RIVET_TUBE :2,5X0,25:RIVET_TUBE :ROHRNIETE :
 :MECH22 :22633 :SICH.HALTER :5x20/6x3: :SICH.HALTER :
 :MECH23 :22633 :SICH.HALTER :5x20/6x3: :SICH.HALTER :
 :MECH24 :22633 :SICH.HALTER :5x20/6x3: :SICH.HALTER :
 :MECH25 :22633 :SICH.HALTER :5x20/6x3: :SICH.HALTER :

:MECH26 :22633 :SICH.HALTER :5x20/6x3: :SICH.HALTER :
:MECH27 :22633 :SICH.HALTER :5x20/6x3: :SICH.HALTER :
:MECH28 :22633 :SICH.HALTER :5x20/6x3: :SICH.HALTER :
:MECH29 :22633 :SICH.HALTER :5x20/6x3: :SICH.HALTER :
:MECH3 :Z12447 : : : : :
:MECH33 :9600 :DIST_BOLT :M3X12 : :DISTANZBOLZEN :
:MECH34 :9600 :DIST_BOLT :M3X12 : :DISTANZBOLZEN :
:MECH35 :9600 :DIST_BOLT :M3X12 : :DISTANZBOLZEN :
:MECH36 :4303 :DIST_BOLT :M3X40 : :DISTANZBOLZEN :
:MECH37 :9600 :DIST_BOLT :M3X12 : :DISTANZBOLZEN :
:MECH38 :9600 :DIST_BOLT :M3X12 : :DISTANZBOLZEN :
:MECH39 :9600 :DIST_BOLT :M3X12 : :DISTANZBOLZEN :
:MECH4 :Z12438 :LABEL : : :BESCHRIFTUNGSFOLI:
: : : : :E :
:MECH40 :4303 :DIST_BOLT :M3X40 : :DISTANZBOLZEN :
:MECH41 :2227 :ISOL.BUCHSE :M3 : :ISOL.BUCHSE :
:MECH42 :2227 :ISOL.BUCHSE :M3 : :ISOL.BUCHSE :
:MECH43 :2227 :ISOL.BUCHSE :M3 : :ISOL.BUCHSE :
:MECH44 :2227 :ISOL.BUCHSE :M3 : :ISOL.BUCHSE :
:MECH45 :2227 :ISOL.BUCHSE :M3 : :ISOL.BUCHSE :
:MECH48 :25584 :SCREW_COUNT_:M3x6 : :SENKSCHR :
:MECH49 :25584 :SCREW_COUNT_:M3x6 : :SENKSCHR :
:MECH5 :Z12444 : : : : :
:MECH50 :25584 :SCREW_COUNT_:M3x6 : :SENKSCHR :
:MECH51 :25584 :SCREW_COUNT_:M3x6 : :SENKSCHR :
:MECH52 :25584 :SCREW_COUNT_:M3x6 : :SENKSCHR :
:MECH53 :25584 :SCREW_COUNT_:M3x6 : :SENKSCHR :
:MECH54 :25584 :SCREW_COUNT_:M3x6 : :SENKSCHR :
:MECH55 :25584 :SCREW_COUNT_:M3x6 : :SENKSCHR :
:MECH56 :25578 :SCREW_COUNT_:M2.5x6 : :SENKSCHR :
:MECH57 :25578 :SCREW_COUNT_:M2.5x6 : :SENKSCHR :
:MECH58 :25566 :SCREW_RND :M2.5x6 : :LINSENSCHRAUBE :
:MECH59 :25566 :SCREW_RND :M2.5x6 : :LINSENSCHRAUBE :
:MECH6 :22667 :EXTRACTOR_HA: : :AUSZIEHGRIF 12TE:
:MECH60 :25568 :SCREW_RND :M2.5x10 : :LINSENSCHRAUBE :
:MECH61 :25568 :SCREW_RND :M2.5x10 : :LINSENSCHRAUBE :

:MECH62 :25568 :SCREW_RND :M2.5x10 : :LINSENSCHRAUBE :
 :MECH63 :25568 :SCREW_RND :M2.5x10 : :LINSENSCHRAUBE :
 :MECH64 :25574 :SCREW_RND :M3x10 : :LINSENSCHRAUBE :
 :MECH65 :25574 :SCREW_RND :M3x10 : :LINSENSCHRAUBE :
 :MECH66 :25574 :SCREW_RND :M3x10 : :LINSENSCHRAUBE :
 :MECH67 :25574 :SCREW_RND :M3x10 : :LINSENSCHRAUBE :
 :MECH68 :25574 :SCREW_RND :M3x10 : :LINSENSCHRAUBE :
 :MECH69 :25574 :SCREW_RND :M3x10 : :LINSENSCHRAUBE :
 :MECH7 :22667 :EXTRACTOR_HA: : :AUSZIEHGRIF 12TE:
 :MECH70 :25574 :SCREW_RND :M3x10 : :LINSENSCHRAUBE :
 :MECH71 :25574 :SCREW_RND :M3x10 : :LINSENSCHRAUBE :
 :MECH72 :25574 :SCREW_RND :M3x10 : :LINSENSCHRAUBE :
 :MECH73 :25574 :SCREW_RND :M3x10 : :LINSENSCHRAUBE :
 :MECH74 :25574 :SCREW_RND :M3x10 : :LINSENSCHRAUBE :
 :MECH75 :25574 :SCREW_RND :M3x10 : :LINSENSCHRAUBE :
 :MECH76 :25574 :SCREW_RND :M3x10 : :LINSENSCHRAUBE :
 :MECH77 :25574 :SCREW_RND :M3x10 : :LINSENSCHRAUBE :
 :MECH78 :25753 :NUT_HEXAGONA:M2.5 : :SK_MUTTER :
 :MECH79 :25753 :NUT_HEXAGONA:M2.5 : :SK_MUTTER :
 :MECH8 :22668 :LEITERPL.HAL: : :LEITERPL.HALTER :
 :MECH80 :25590 :WASHER_FAN :M2,5 : :FAECHERSCHEIBE :
 :MECH81 :25590 :WASHER_FAN :M2,5 : :FAECHERSCHEIBE :
 :MECH82 :25590 :WASHER_FAN :M2,5 : :FAECHERSCHEIBE :
 :MECH83 :25590 :WASHER_FAN :M2,5 : :FAECHERSCHEIBE :
 :MECH84 :25590 :WASHER_FAN :M2,5 : :FAECHERSCHEIBE :
 :MECH85 :25590 :WASHER_FAN :M2,5 : :FAECHERSCHEIBE :
 :MECH86 :25589 :WASHER :M2.5 : :UNTERLAGSCHEIBE :
 :MECH87 :25589 :WASHER :M2.5 : :UNTERLAGSCHEIBE :
 :MECH88 :21486 :TRANS ZUB WA:TO220 : :TRANS ZUB WAERMRL:
 : : : : :EITS :
 :MECH9 :22668 :LEITERPL.HAL: : :LEITERPL.HALTER :
 :MECH90 :21486 :TRANS ZUB WA:TO220 : :TRANS ZUB WAERMRL:
 : : : : :EITS :
 :MECH92 :21486 :TRANS ZUB WA:TO220 : :TRANS ZUB WAERMRL:
 : : : : :EITS :
 :MECH93 :21486 :TRANS ZUB WA:TO220 : :TRANS ZUB WAERMRL:

```

# Company : SPECTROSPIN AG
# Product : AQR
# Print-Name : Power-Supply Print-Number: Z3P2966
# Sheet-Name : UNI-Modul DWG-Number : Z4S5775
# Sheet-Name : UNI-Modul DWG-Number : Z4S5776
# Sheet-Name : UNI-Modul DWG-Number : Z4S5777
# Sheet-Name : UNI-Modul DWG-Number : Z4S5778
# Sheet-Name : VARIANT DWG-Number : Z3S5811A
# Sheet-Name : Mechanical Parts DWG-Number : Z3S5809
# Sheet-Name : Mechanical Parts DWG-Number : Z3S5810A
# Date-Time : 30.Jul.93 17:14:41 Account : be
#
# Variant : PSB2
#
#.....
#ANZ :PHY_LOC :CAT_NM :PART_NM :VALUE :SHAPE :NOTE :
#.....:
# :Resistors
:R1 :8762 :RES :180 :R04010A : :
:R2 :8762 :RES :180 :R04010A : :
:R3 :20817 :RES :270 :R04010A : :
:R4 :20817 :RES :270 :R04010A : :
:R5 :20817 :RES :270 :R04010A : :
:R6 :20817 :RES :270 :R04010A : :
:R7 :20817 :RES :270 :R04010A : :
:R8 :20820 :RES :33K :R04010A : :
:R8_8 :8543 :RES :1.8K :R04010A : :
:R9 :20820 :RES :33K :R04010A : :
:R9_9 :8543 :RES :1.8K :R04010A : :
:R10 :1012 :RES :1.5K :R04010A : :
:R10_10 :4677 :RES :12K :R04010A : :
:R11 :1012 :RES :1.5K :R04010A : :
:R11_11 :4677 :RES :12K :R04010A : :
:R12 :1012 :RES :1.5K :R04010A : :

```



```

:C23 :1985 :CAP_POL :100U :C020E040 : :
:C24 :1985 :CAP_POL :100U :C020E040 : :
:C25 :1985 :CAP_POL :100U :C020E040 : :
:C26 :1985 :CAP_POL :100U :C020E040 : :
:C27 :1985 :CAP_POL :100U :C020E040 : :
:C28 :1985 :CAP_POL :100U :C020E040 : :
#.....:.....:.....:.....:.....:.....:
# :Diodes
:D1 :4326 :1N4004 : :DO41 : :
:D2 :4326 :1N4004 : :DO41 : :
:D3 :4326 :1N4004 : :DO41 : :
:D4 :4326 :1N4004 : :DO41 : :
:D5 :4326 :1N4004 : :DO41 : :
:D6 :4326 :1N4004 : :DO41 : :
:D7 :4326 :1N4004 : :DO41 : :
#.....:.....:.....:.....:.....:.....:
# :ICs
:IC1 :19161 :LT1083CP : :TO220_SPC : :
:IC2 :42146 :LM338T : :TO220_SPC : :
:IC3 :42146 :LM338T : :TO220_SPC : :
:IC4 :42146 :LM338T : :TO220_SPC : :
:IC5 :19161 :LT1083CP : :TO220_SPC : :
:IC6 :42146 :LM338T : :TO220_SPC : :
:IC7 :42146 :LM338T : :TO220_SPC : :
#.....:.....:.....:.....:.....:.....:
# :Connectors
84 :J1 :6948 :41612A96MC : :41612A96MC : :
15 :J2 :21904 :41612A15MH : :41612A15MH : :
#.....:.....:.....:.....:.....:.....:
# :divers
:F1 :2258 :FUSE :6.3A T :F_6_3X32 : :
:F2 :2252 :FUSE :1.25A T :F_6_3X32 : :
:F3 :2254 :FUSE :2.0A T :F_6_3X32 : :
:F4 :2254 :FUSE :2.0A T :F_6_3X32 : :
:F5 :4907 :FUSE :6,3A T :F_6_3X32 : : (for ECL01 and higher)
:F6 :2256 :FUSE :3.15A T :F_6_3X32 : :

```

```

:F7 :2252 :FUSE :1.25A T :F_6_3X32 : :
:GR1 :362 :GRAETZ_SPC :KBPC602 :BR_SPC : :
:GR2 :362 :GRAETZ_SPC :KBPC602 :BR_SPC : :
:GR3 :362 :GRAETZ_SPC :KBPC602 :BR_SPC : :
:GR4 :362 :GRAETZ_SPC :KBPC602 :BR_SPC : :
:GR5 :362 :GRAETZ_SPC :KBPC602 :BR_SPC : :
:GR6 :362 :GRAETZ_SPC :KBPC602 :BR_SPC : :
:GR7 :362 :GRAETZ_SPC :KBPC602 :BR_SPC : :
:JU10 :20448 :SOLDER_SPRIN: :LOTBUG11 :LOETBUEGEL :
:JU12 :20448 :SOLDER_SPRIN: :LOTBUG11 :LOETBUEGEL :
:JU14 :20448 :SOLDER_SPRIN: :LOTBUG11 :LOETBUEGEL :
:JU8 :20448 :SOLDER_SPRIN: :LOTBUG11 :LOETBUEGEL :
:LED1 :21866 :LED :GRUEN :LED3 : :
:LED2 :21866 :LED :GRUEN :LED3 : :
:LED3 :21866 :LED :GRUEN :LED3 : :
:LED4 :21866 :LED :GRUEN :LED3 : :
:LED5 :21866 :LED :GRUEN :LED3 : :
:LED6 :21866 :LED :GRUEN :LED3 : :
:LED7 :21866 :LED :GRUEN :LED3 : :
:MECH1 :Z12472 :PCB : :Z3P2966 :PRINT :
:MECH10 :22598 :SUMMENBEFEST: : :SUMMENBEFESTIGUNG:
: : : : : LINKS :
:MECH100 :25573 :SCREW_RND :M3x8 : :LINSENSCHRAUBE :
:MECH101 :25573 :SCREW_RND :M3x8 : :LINSENSCHRAUBE :
:MECH11 :22599 :SUMMENBEFEST: : :SUMMENBEFESTIGUNG:
: : : : : RECHTS :
:MECH12 :Z12153 :HALSSCHRAUBE:M2.5x8.5: :HALSSCHRAUBE :
:MECH13 :Z12153 :HALSSCHRAUBE:M2.5x8.5: :HALSSCHRAUBE :
:MECH14 :Z12153 :HALSSCHRAUBE:M2.5x8.5: :HALSSCHRAUBE :
:MECH15 :Z12153 :HALSSCHRAUBE:M2.5x8.5: :HALSSCHRAUBE :
:MECH16 :22633 :SICH.HALTER :5x20/6x3: :SICH.HALTER :
:MECH17 :22633 :SICH.HALTER :5x20/6x3: :SICH.HALTER :
:MECH18 :22633 :SICH.HALTER :5x20/6x3: :SICH.HALTER :
:MECH18 :25648 :RIVET_TUBE :2,5X0,3X:RIVET_TUBE :ROHRNIETE :
:MECH19 :22633 :SICH.HALTER :5x20/6x3: :SICH.HALTER :
:MECH19 :25648 :RIVET_TUBE :2,5X0,3X:RIVET_TUBE :ROHRNIETE :

```

:MECH2 :Z12473 :HEAT_SINK :Z2M7650 :KK100X230 :KUEHLKOERPER :
 :MECH20 :22633 :SICH.HALTER :5x20/6x3: :SICH.HALTER :
 :MECH20 :25689 :RIVET_TUBE :2,5X0,25:RIVET_TUBE :ROHRNIETE :
 :MECH21 :22633 :SICH.HALTER :5x20/6x3: :SICH.HALTER :
 :MECH21 :25689 :RIVET_TUBE :2,5X0,25:RIVET_TUBE :ROHRNIETE :
 :MECH22 :22633 :SICH.HALTER :5x20/6x3: :SICH.HALTER :
 :MECH23 :22633 :SICH.HALTER :5x20/6x3: :SICH.HALTER :
 :MECH24 :22633 :SICH.HALTER :5x20/6x3: :SICH.HALTER :
 :MECH25 :22633 :SICH.HALTER :5x20/6x3: :SICH.HALTER :
 :MECH26 :22633 :SICH.HALTER :5x20/6x3: :SICH.HALTER :
 :MECH27 :22633 :SICH.HALTER :5x20/6x3: :SICH.HALTER :
 :MECH28 :22633 :SICH.HALTER :5x20/6x3: :SICH.HALTER :
 :MECH29 :22633 :SICH.HALTER :5x20/6x3: :SICH.HALTER :
 :MECH3 :Z12448 : : : : :
 :MECH33 :9600 :DIST_BOLT :M3X12 : :DISTANZBOLZEN :
 :MECH34 :9600 :DIST_BOLT :M3X12 : :DISTANZBOLZEN :
 :MECH35 :9600 :DIST_BOLT :M3X12 : :DISTANZBOLZEN :
 :MECH36 :4303 :DIST_BOLT :M3X40 : :DISTANZBOLZEN :
 :MECH37 :9600 :DIST_BOLT :M3X12 : :DISTANZBOLZEN :
 :MECH38 :9600 :DIST_BOLT :M3X12 : :DISTANZBOLZEN :
 :MECH39 :9600 :DIST_BOLT :M3X12 : :DISTANZBOLZEN :
 :MECH4 :Z12438 :LABEL : : :BESCHRIFTUNGSFOLI:
 : : : : :E :
 :MECH40 :4303 :DIST_BOLT :M3X40 : :DISTANZBOLZEN :
 :MECH41 :2227 :ISOL.BUCHSE :M3 : :ISOL.BUCHSE :
 :MECH42 :2227 :ISOL.BUCHSE :M3 : :ISOL.BUCHSE :
 :MECH43 :2227 :ISOL.BUCHSE :M3 : :ISOL.BUCHSE :
 :MECH44 :2227 :ISOL.BUCHSE :M3 : :ISOL.BUCHSE :
 :MECH45 :2227 :ISOL.BUCHSE :M3 : :ISOL.BUCHSE :
 :MECH48 :25584 :SCREW_COUNT_:M3x6 : :SENKSCHR :
 :MECH49 :25584 :SCREW_COUNT_:M3x6 : :SENKSCHR :
 :MECH5 :Z12445 : : : : :
 :MECH50 :25584 :SCREW_COUNT_:M3x6 : :SENKSCHR :
 :MECH51 :25584 :SCREW_COUNT_:M3x6 : :SENKSCHR :
 :MECH52 :25584 :SCREW_COUNT_:M3x6 : :SENKSCHR :
 :MECH53 :25584 :SCREW_COUNT_:M3x6 : :SENKSCHR :

:MECH54 :25584 :SCREW_COUNT_:M3x6 : :SENKSCHR :
:MECH55 :25584 :SCREW_COUNT_:M3x6 : :SENKSCHR :
:MECH56 :25578 :SCREW_COUNT_:M2.5x6 : :SENKSCHR :
:MECH57 :25578 :SCREW_COUNT_:M2.5x6 : :SENKSCHR :
:MECH58 :25566 :SCREW_RND :M2.5x6 : :LINSENSCHRAUBE :
:MECH59 :25566 :SCREW_RND :M2.5x6 : :LINSENSCHRAUBE :
:MECH6 :22667 :EXTRACTOR_HA: : :AUSZIEHGRIFF 12TE:
:MECH60 :25568 :SCREW_RND :M2.5x10 : :LINSENSCHRAUBE :
:MECH61 :25568 :SCREW_RND :M2.5x10 : :LINSENSCHRAUBE :
:MECH62 :25568 :SCREW_RND :M2.5x10 : :LINSENSCHRAUBE :
:MECH63 :25568 :SCREW_RND :M2.5x10 : :LINSENSCHRAUBE :
:MECH64 :25574 :SCREW_RND :M3x10 : :LINSENSCHRAUBE :
:MECH65 :25574 :SCREW_RND :M3x10 : :LINSENSCHRAUBE :
:MECH66 :25574 :SCREW_RND :M3x10 : :LINSENSCHRAUBE :
:MECH67 :25574 :SCREW_RND :M3x10 : :LINSENSCHRAUBE :
:MECH68 :25574 :SCREW_RND :M3x10 : :LINSENSCHRAUBE :
:MECH69 :25574 :SCREW_RND :M3x10 : :LINSENSCHRAUBE :
:MECH7 :22667 :EXTRACTOR_HA: : :AUSZIEHGRIFF 12TE:
:MECH70 :25574 :SCREW_RND :M3x10 : :LINSENSCHRAUBE :
:MECH71 :25574 :SCREW_RND :M3x10 : :LINSENSCHRAUBE :
:MECH72 :25574 :SCREW_RND :M3x10 : :LINSENSCHRAUBE :
:MECH73 :25574 :SCREW_RND :M3x10 : :LINSENSCHRAUBE :
:MECH74 :25574 :SCREW_RND :M3x10 : :LINSENSCHRAUBE :
:MECH75 :25574 :SCREW_RND :M3x10 : :LINSENSCHRAUBE :
:MECH76 :25574 :SCREW_RND :M3x10 : :LINSENSCHRAUBE :
:MECH77 :25574 :SCREW_RND :M3x10 : :LINSENSCHRAUBE :
:MECH78 :25753 :NUT_HEXAGONA:M2.5 : :SK_MUTTER :
:MECH79 :25753 :NUT_HEXAGONA:M2.5 : :SK_MUTTER :
:MECH8 :22668 :LEITERPL.HAL: : :LEITERPL.HALTER :
:MECH80 :25590 :WASHER_FAN :M2,5 : :FAECHERSCHEIBE :
:MECH81 :25590 :WASHER_FAN :M2,5 : :FAECHERSCHEIBE :
:MECH82 :25590 :WASHER_FAN :M2,5 : :FAECHERSCHEIBE :
:MECH83 :25590 :WASHER_FAN :M2,5 : :FAECHERSCHEIBE :
:MECH84 :25590 :WASHER_FAN :M2,5 : :FAECHERSCHEIBE :
:MECH85 :25590 :WASHER_FAN :M2,5 : :FAECHERSCHEIBE :
:MECH86 :25589 :WASHER :M2.5 : :UNTERLAGSCHEIBE :

```

# Company : SPECTROSPIN AG
# Product : AQR
# Print-Name : Power-Supply Print-Number: Z3P2966
# Sheet-Name : UNI-Modul DWG-Number : Z4S5775
# Sheet-Name : UNI-Modul DWG-Number : Z4S5776
# Sheet-Name : UNI-Modul DWG-Number : Z4S5777
# Sheet-Name : UNI-Modul DWG-Number : Z4S5778
# Sheet-Name : VARIANT DWG-Number : Z3S5811A
# Sheet-Name : Mechanical Parts DWG-Number : Z3S5809
# Sheet-Name : Mechanical Parts DWG-Number : Z3S5810A
# Date-Time : 30.Jul.93 17:14:41 Account : be
#
# Variant : PSB3
#
#.....
#ANZ :PHY_LOC :CAT_NM :PART_NM :VALUE :SHAPE :NOTE :
#.....:
# :Resistors
:R1 :20817 :RES :270 :R04010A : :
:R2 :8762 :RES :180 :R04010A : :
:R4 :8762 :RES :180 :R04010A : :
:R5 :8762 :RES :180 :R04010A : :
:R6 :8762 :RES :180 :R04010A : :
:R7 :20817 :RES :270 :R04010A : :
:R8 :20868 :RES :390 :R04010A : :
:R8_8 :20578 :RES :4.7K :R04010A : :
:R9 :1012 :RES :1.5K :R04010A : :
:R9_9 :2769 :RES :3.3K :R04010A : :
:R11 :4716 :RES :820 :R04010A : :
:R11_11 :3960 :RES :8.2K :R04010A : :
:R12 :4716 :RES :820 :R04010A : :
:R12_12 :3960 :RES :8.2K :R04010A : :
:R13 :4716 :RES :820 :R04010A : :
:R13_13 :3960 :RES :8.2K :R04010A : :

```



```
# :Diodes
:D1 :4326 :1N4004 : :DO41 : :
:D2 :4326 :1N4004 : :DO41 : :
:D4 :4326 :1N4004 : :DO41 : :
:D5 :4326 :1N4004 : :DO41 : :
:D6 :4326 :1N4004 : :DO41 : :
:D7 :4326 :1N4004 : :DO41 : :
#.....:
# :ICs
:IC1 :42146 :LM338T : :TO220_SPC : :
:IC2 :42146 :LM338T : :TO220_SPC : :
:IC4 :42146 :LM338T : :TO220_SPC : :
:IC5 :42146 :LM338T : :TO220_SPC : :
:IC6 :42146 :LM338T : :TO220_SPC : :
:IC7 :19161 :LT1083CP : :TO220_SPC : :
#.....:
# :Connectors
84 :J1 :6948 :41612A96MC : :41612A96MC : :
15 :J2 :21904 :41612A15MH : :41612A15MH : :
#.....:
# :divers
:F1 :2254 :FUSE :2.0A T :F_6_3X32 : :
:F2 :2250 :FUSE :0.8A T :F_6_3X32 : :
:F4 :2254 :FUSE :2.0A T :F_6_3X32 : :
:F5 :2255 :FUSE :2.5A T :F_6_3X32 : :
:F6 :2255 :FUSE :2.5A T :F_6_3X32 : :
:F7 :4907 :FUSE :5A T :F_6_3X32 : :
:GR1 :362 :GRAETZ_SPC :KBPC602 :BR_SPC : :
:GR2 :362 :GRAETZ_SPC :KBPC602 :BR_SPC : :
:GR4 :362 :GRAETZ_SPC :KBPC602 :BR_SPC : :
:GR5 :362 :GRAETZ_SPC :KBPC602 :BR_SPC : :
:GR6 :362 :GRAETZ_SPC :KBPC602 :BR_SPC : :
:GR7 :362 :GRAETZ_SPC :KBPC602 :BR_SPC : :
:JU12 :20448 :SOLDER_SPRIN: :LOTBUG11 :LOETBUEGEL :
:JU15 :20448 :SOLDER_SPRIN: :LOTBUG11 :LOETBUEGEL :
:LED1 :21866 :LED :GRUEN :LED3 : :
```

:LED2 :21866 :LED :GRUEN :LED3 : :
 :LED3 :21866 :LED :GRUEN :LED3 : :
 :LED5 :21866 :LED :GRUEN :LED3 : :
 :LED6 :21866 :LED :GRUEN :LED3 : :
 :LED7 :21866 :LED :GRUEN :LED3 : :
 :MECH1 :Z12472 :PCB : :Z3P2966 :PRINT :
 :MECH10 :22598 :SUMMENBEFEST: : :SUMMENBEFESTIGUNG:
 :MECH100 :25573 :SCREW_RND :M3x8 : :LINSENSCHRAUBE :
 :MECH101 :25573 :SCREW_RND :M3x8 : :LINSENSCHRAUBE :
 :MECH11 :22599 :SUMMENBEFEST: : :SUMMENBEFESTIGUNG:
 :MECH12 :Z12153 :HALSSCHRAUBE:M2.5x8.5: :HALSSCHRAUBE :
 :MECH13 :Z12153 :HALSSCHRAUBE:M2.5x8.5: :HALSSCHRAUBE :
 :MECH14 :Z12153 :HALSSCHRAUBE:M2.5x8.5: :HALSSCHRAUBE :
 :MECH15 :Z12153 :HALSSCHRAUBE:M2.5x8.5: :HALSSCHRAUBE :
 :MECH16 :22633 :SICH.HALTER :5x20/6x3: :SICH.HALTER :
 :MECH17 :22633 :SICH.HALTER :5x20/6x3: :SICH.HALTER :
 :MECH18 :22633 :SICH.HALTER :5x20/6x3: :SICH.HALTER :
 :MECH18 :25648 :RIVET_TUBE :2,5X0,3X:RIVET_TUBE :ROHRNIETE :
 :MECH19 :22633 :SICH.HALTER :5x20/6x3: :SICH.HALTER :
 :MECH19 :25648 :RIVET_TUBE :2,5X0,3X:RIVET_TUBE :ROHRNIETE :
 :MECH2 :Z12473 :HEAT_SINK :Z2M7650 :KK100X230 :KUEHLKOERPER :
 :MECH20 :22633 :SICH.HALTER :5x20/6x3: :SICH.HALTER :
 :MECH20 :25689 :RIVET_TUBE :2,5X0,25:RIVET_TUBE :ROHRNIETE :
 :MECH21 :22633 :SICH.HALTER :5x20/6x3: :SICH.HALTER :
 :MECH21 :25689 :RIVET_TUBE :2,5X0,25:RIVET_TUBE :ROHRNIETE :
 :MECH22 :22633 :SICH.HALTER :5x20/6x3: :SICH.HALTER :
 :MECH23 :22633 :SICH.HALTER :5x20/6x3: :SICH.HALTER :
 :MECH24 :22633 :SICH.HALTER :5x20/6x3: :SICH.HALTER :
 :MECH25 :22633 :SICH.HALTER :5x20/6x3: :SICH.HALTER :
 :MECH26 :22633 :SICH.HALTER :5x20/6x3: :SICH.HALTER :
 :MECH27 :22633 :SICH.HALTER :5x20/6x3: :SICH.HALTER :
 :MECH3 :Z12449 : : : : :
 :MECH33 :9600 :DIST_BOLT :M3X12 : :DISTANZBOLZEN :
 :MECH34 :9600 :DIST_BOLT :M3X12 : :DISTANZBOLZEN :
 :MECH35 :9600 :DIST_BOLT :M3X12 : :DISTANZBOLZEN :
 :MECH36 :4303 :DIST_BOLT :M3X40 : :DISTANZBOLZEN :

:MECH37 :9600 :DIST_BOLT :M3X12 : :DISTANZBOLZEN :
:MECH38 :9600 :DIST_BOLT :M3X12 : :DISTANZBOLZEN :
:MECH39 :9600 :DIST_BOLT :M3X12 : :DISTANZBOLZEN :
:MECH4 :Z12438 :LABEL : : :BESCHRIFTUNGSFOLI:
:MECH40 :4303 :DIST_BOLT :M3X40 : :DISTANZBOLZEN :
:MECH41 :2227 :ISOL.BUCHSE :M3 : :ISOL.BUCHSE :
:MECH42 :2227 :ISOL.BUCHSE :M3 : :ISOL.BUCHSE :
:MECH43 :2227 :ISOL.BUCHSE :M3 : :ISOL.BUCHSE :
:MECH44 :2227 :ISOL.BUCHSE :M3 : :ISOL.BUCHSE :
:MECH45 :2227 :ISOL.BUCHSE :M3 : :ISOL.BUCHSE :
:MECH48 :25584 :SCREW_COUNT_:M3x6 : :SENKSCHR :
:MECH49 :25584 :SCREW_COUNT_:M3x6 : :SENKSCHR :
:MECH5 :Z12446 : : : :
:MECH50 :25584 :SCREW_COUNT_:M3x6 : :SENKSCHR :
:MECH51 :25584 :SCREW_COUNT_:M3x6 : :SENKSCHR :
:MECH52 :25584 :SCREW_COUNT_:M3x6 : :SENKSCHR :
:MECH53 :25584 :SCREW_COUNT_:M3x6 : :SENKSCHR :
:MECH54 :25584 :SCREW_COUNT_:M3x6 : :SENKSCHR :
:MECH55 :25584 :SCREW_COUNT_:M3x6 : :SENKSCHR :
:MECH56 :25578 :SCREW_COUNT_:M2.5x6 : :SENKSCHR :
:MECH57 :25578 :SCREW_COUNT_:M2.5x6 : :SENKSCHR :
:MECH58 :25566 :SCREW_RND :M2.5x6 : :LINSENSCHRAUBE :
:MECH59 :25566 :SCREW_RND :M2.5x6 : :LINSENSCHRAUBE :
:MECH6 :22667 :EXTRACTOR_HA: : :AUSZIEHGRIFF 12TE:
:MECH60 :25568 :SCREW_RND :M2.5x10 : :LINSENSCHRAUBE :
:MECH61 :25568 :SCREW_RND :M2.5x10 : :LINSENSCHRAUBE :
:MECH62 :25568 :SCREW_RND :M2.5x10 : :LINSENSCHRAUBE :
:MECH63 :25568 :SCREW_RND :M2.5x10 : :LINSENSCHRAUBE :
:MECH64 :25574 :SCREW_RND :M3x10 : :LINSENSCHRAUBE :
:MECH65 :25574 :SCREW_RND :M3x10 : :LINSENSCHRAUBE :
:MECH66 :25574 :SCREW_RND :M3x10 : :LINSENSCHRAUBE :
:MECH67 :25574 :SCREW_RND :M3x10 : :LINSENSCHRAUBE :
:MECH68 :25574 :SCREW_RND :M3x10 : :LINSENSCHRAUBE :
:MECH69 :25574 :SCREW_RND :M3x10 : :LINSENSCHRAUBE :
:MECH7 :22667 :EXTRACTOR_HA: : :AUSZIEHGRIFF 12TE:
:MECH70 :25574 :SCREW_RND :M3x10 : :LINSENSCHRAUBE :

Scheme Power-Supply-Adapter (PSD1)

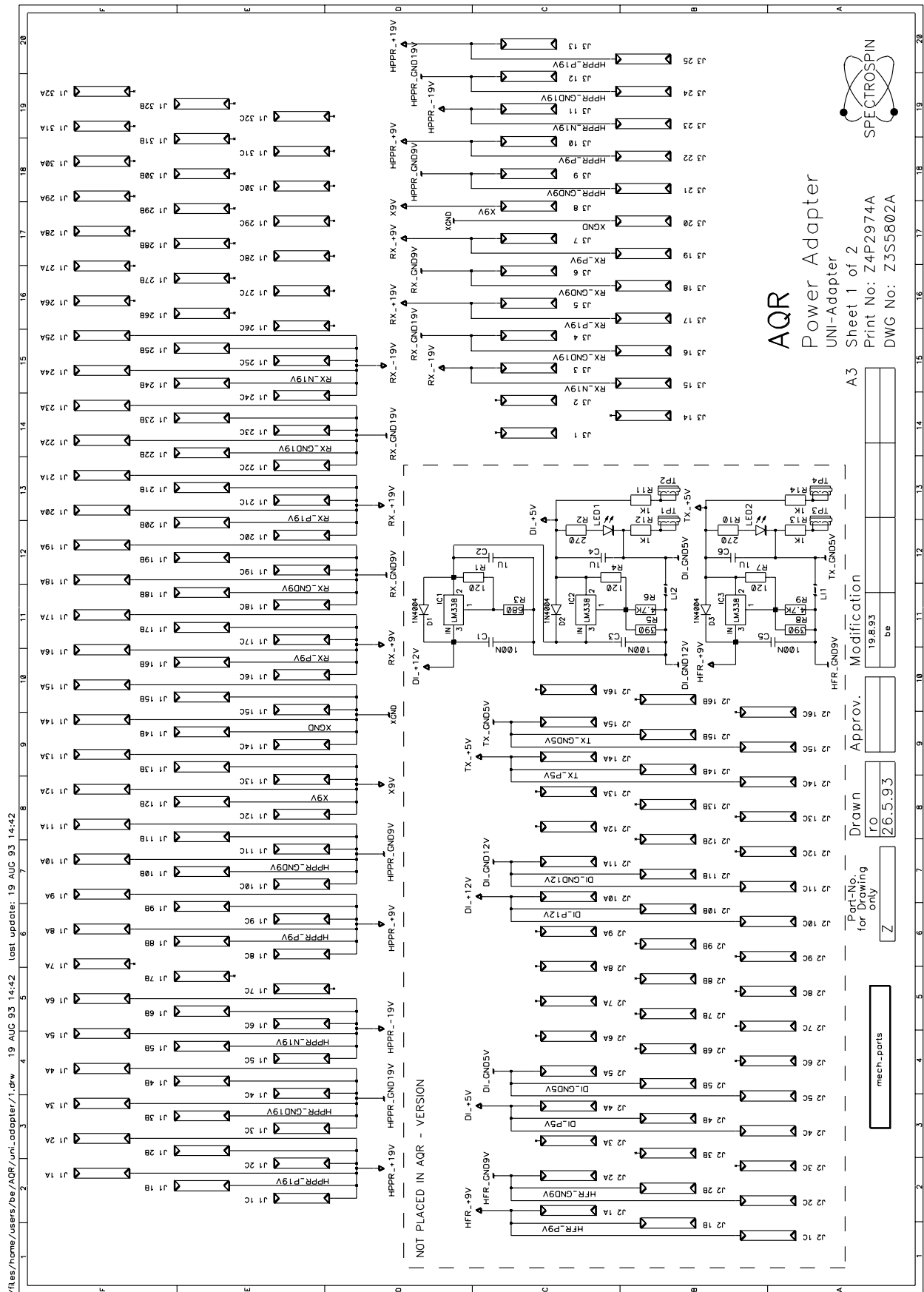

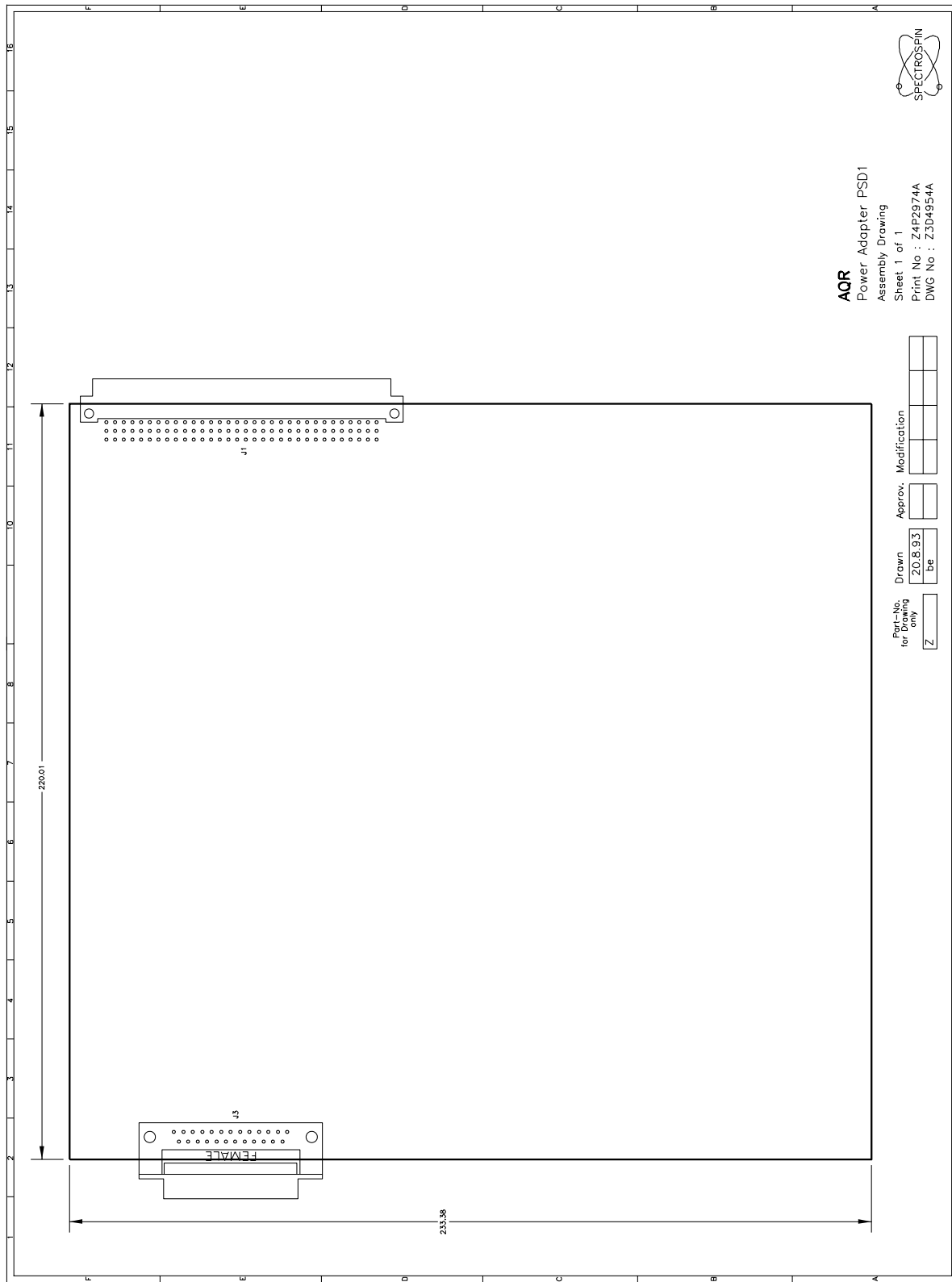

AQR
 Power Adapter PSD1
 Assembly Drawing
 Sheet 1 of 1
 Print No : Z4P2974A
 DWG No : Z3D4954A



Part-No. for Drawing only	Drawn	Approv.	Modification
Z	ZO.B.93 be		

/Res/home/users/be/AQR/aqr-user-bus/3.drw 22 JUL 93 10:44 last update: 22 JUL 93 10:43

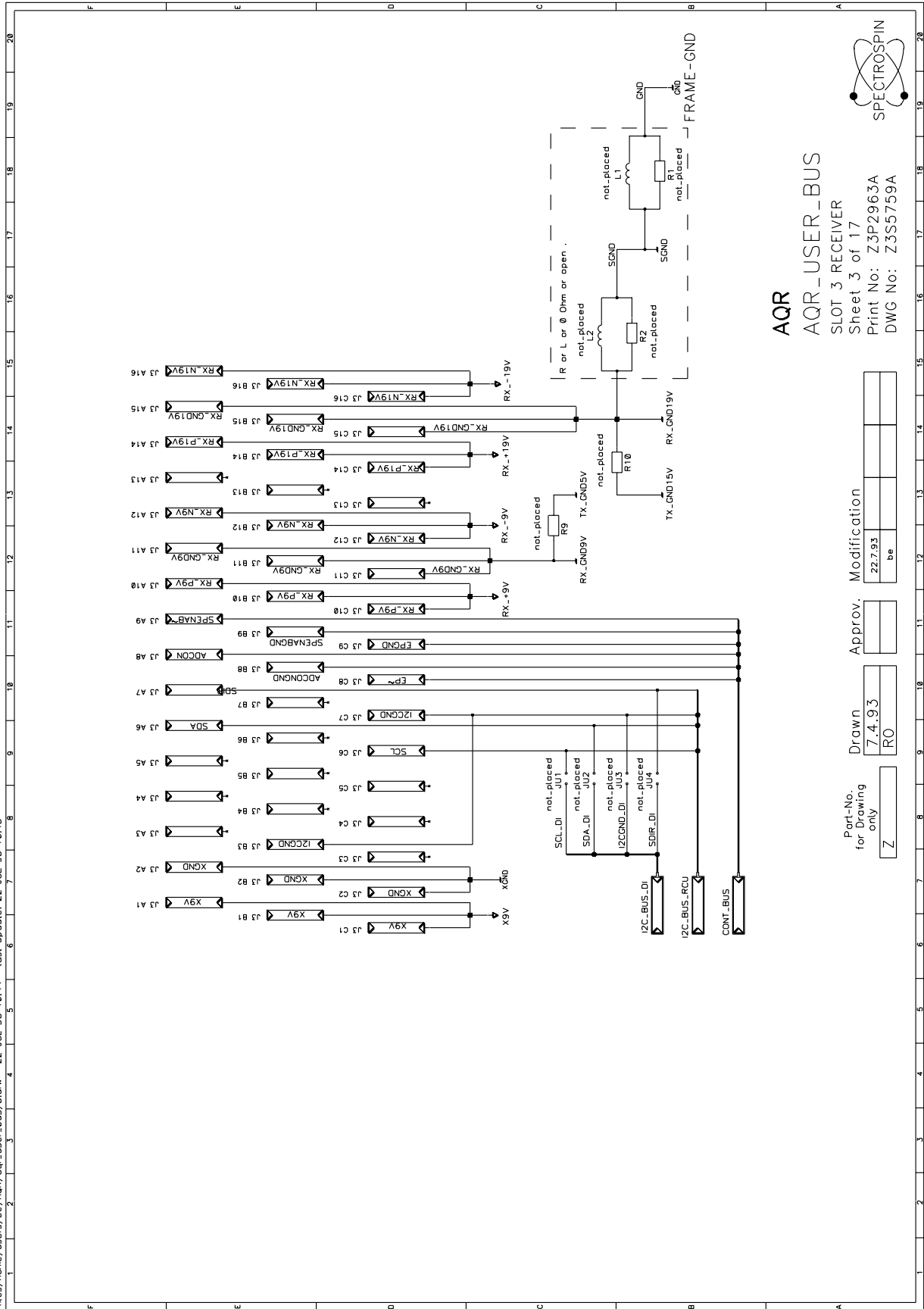

AQR
AQR_USER_BUS
 SLOT 3 RECEIVER
 Sheet 3 of 17
 Print No: Z3P2963A
 DWG No: Z3S5759A

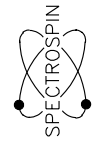

Part-No. for Drawing only	Drawn	Approv.	Modification
Z	7.4.93 RO		22.7.93 be

/Res/home/users/be/AQR/aqr-user-bus/4.drw 22 JUL 93 10:08 last update: 22 JUL 93 10:07

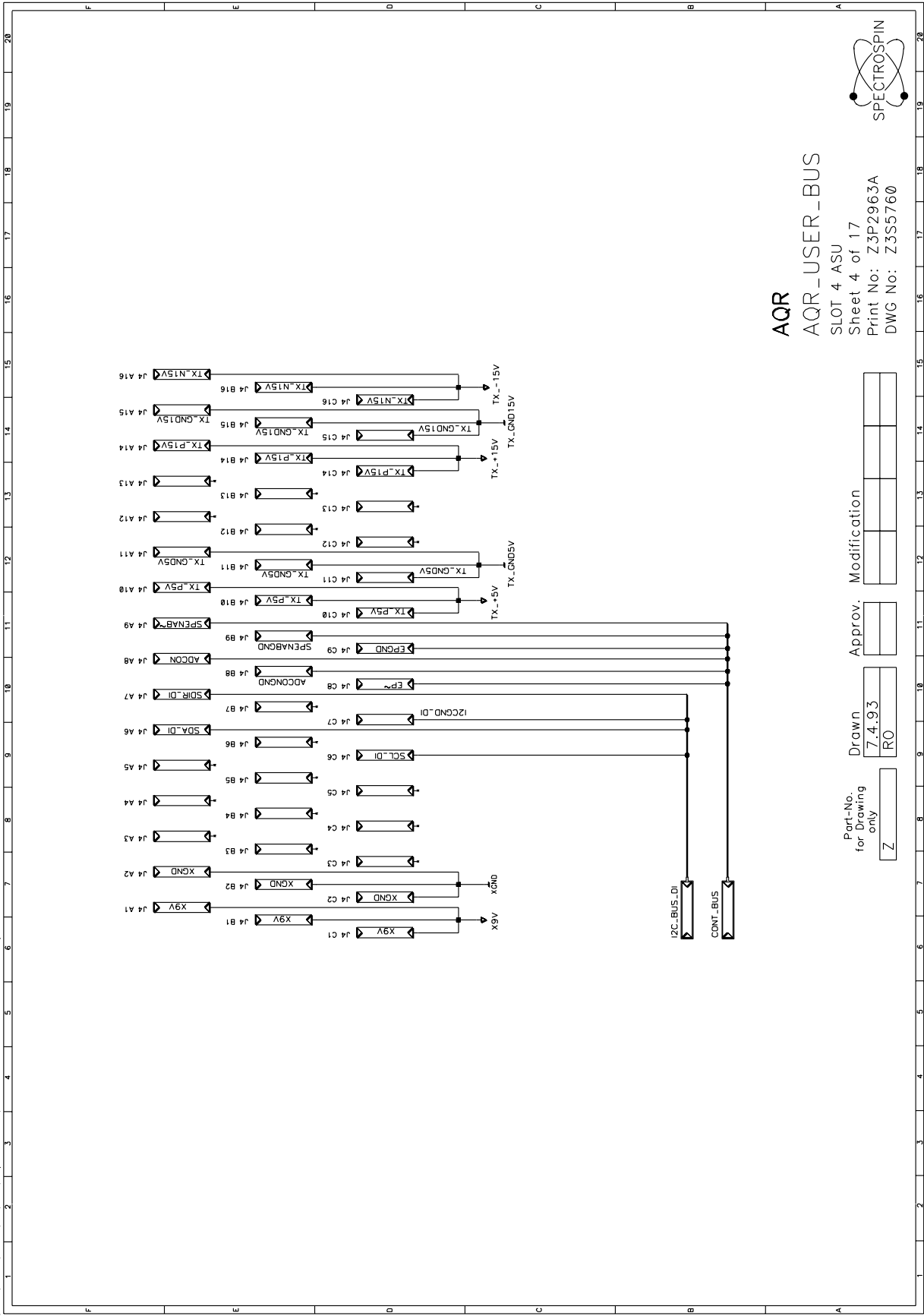

AQR
AQR_USER_BUS
 SLOT 4 ASU
 Sheet 4 of 17
 Print No: Z3P2963A
 DWG No: Z3S5760

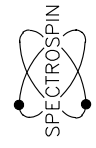

Part-No. for Drawing only	Drawn	Approv.	Modification
Z	7.4.93 RO		

/Res/home/users/be/AQR/aqr-user-bus/7.drw 22 JUL 93 10:46 Last update: 22 JUL 93 10:46

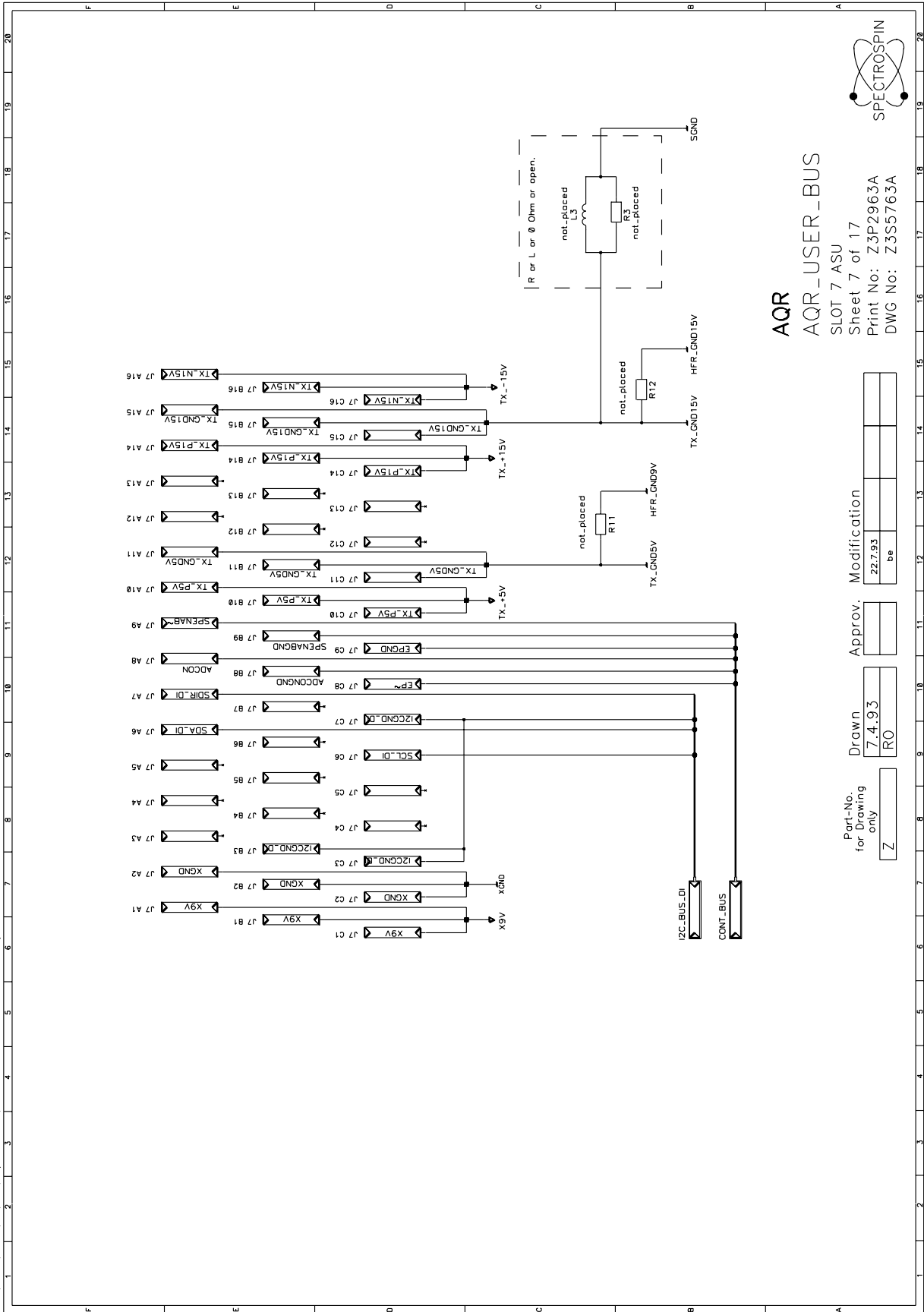

AQR
AQR_USER_BUS

SLOT 7 ASU
 Sheet 7 of 17
 Print No: Z3P2963A
 DWG No: Z3S5763A

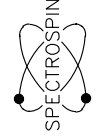

Part-No. for Drawing only	Drawn	Approv.	Modification
Z	7.4.93 RO		22.7.93 be

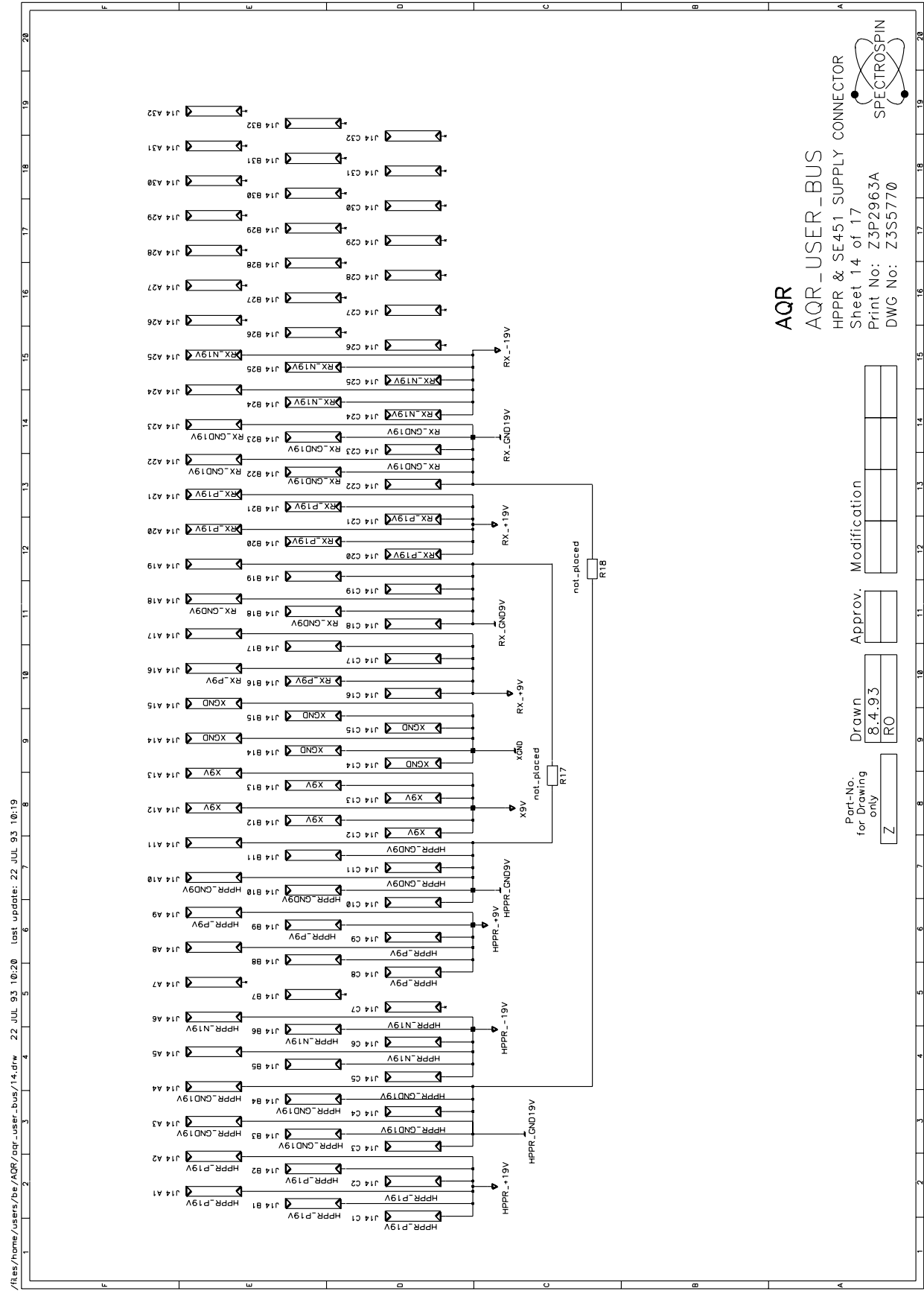

/Res/home/users/be/AQR/aqr-user-bus/15.dwg 22 JUL 93 10:20 Last updated: 22 JUL 93 10:20

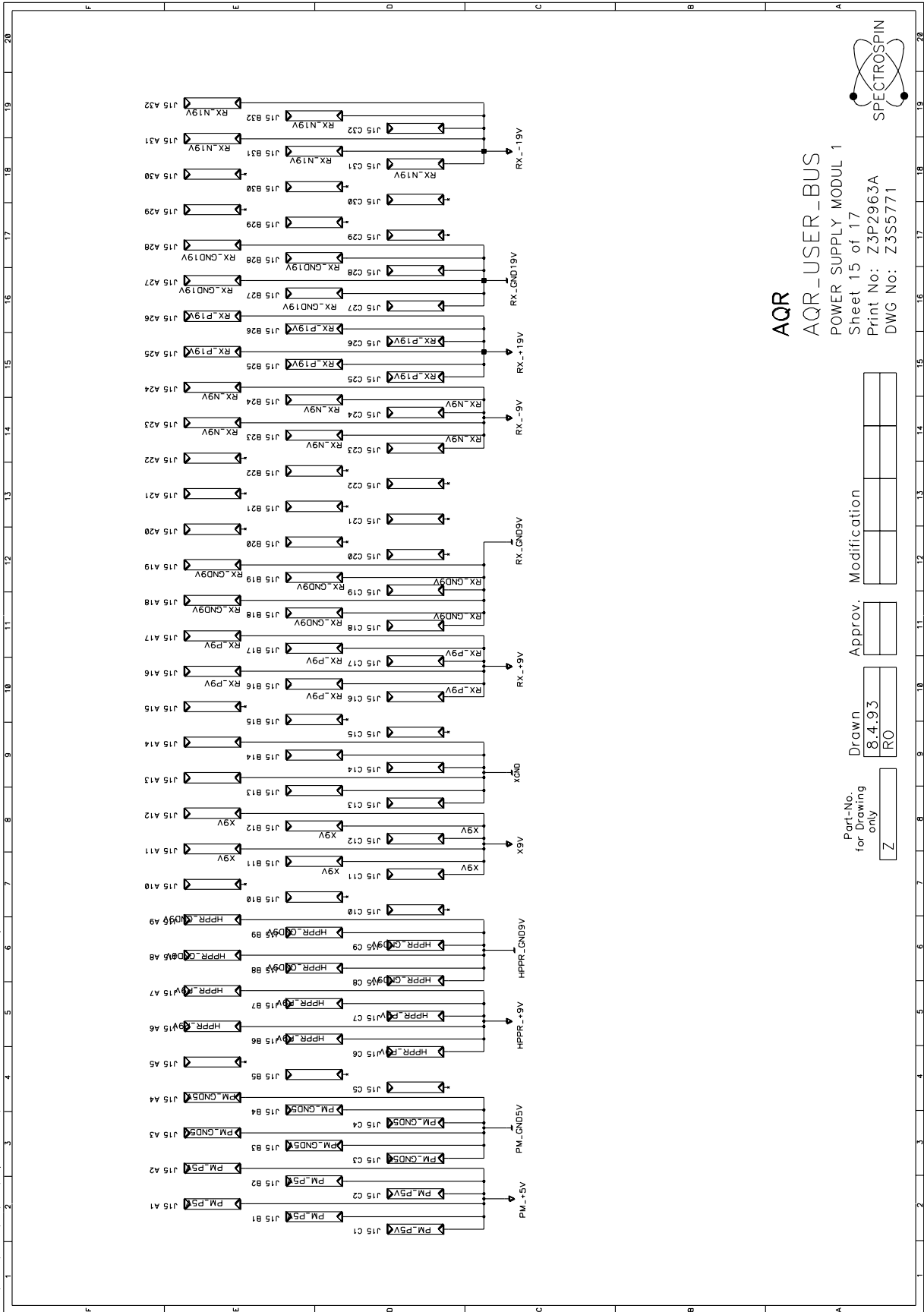

AQR
AQR_USER_BUS
 POWER SUPPLY MODUL 1
 Sheet 15 of 17
 Print No: Z3P2963A
 DWG No: Z3S5771

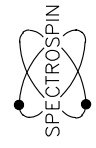

Part-No. for Drawing only:

Drawn	8.4.93	RO	Approv.	Modification

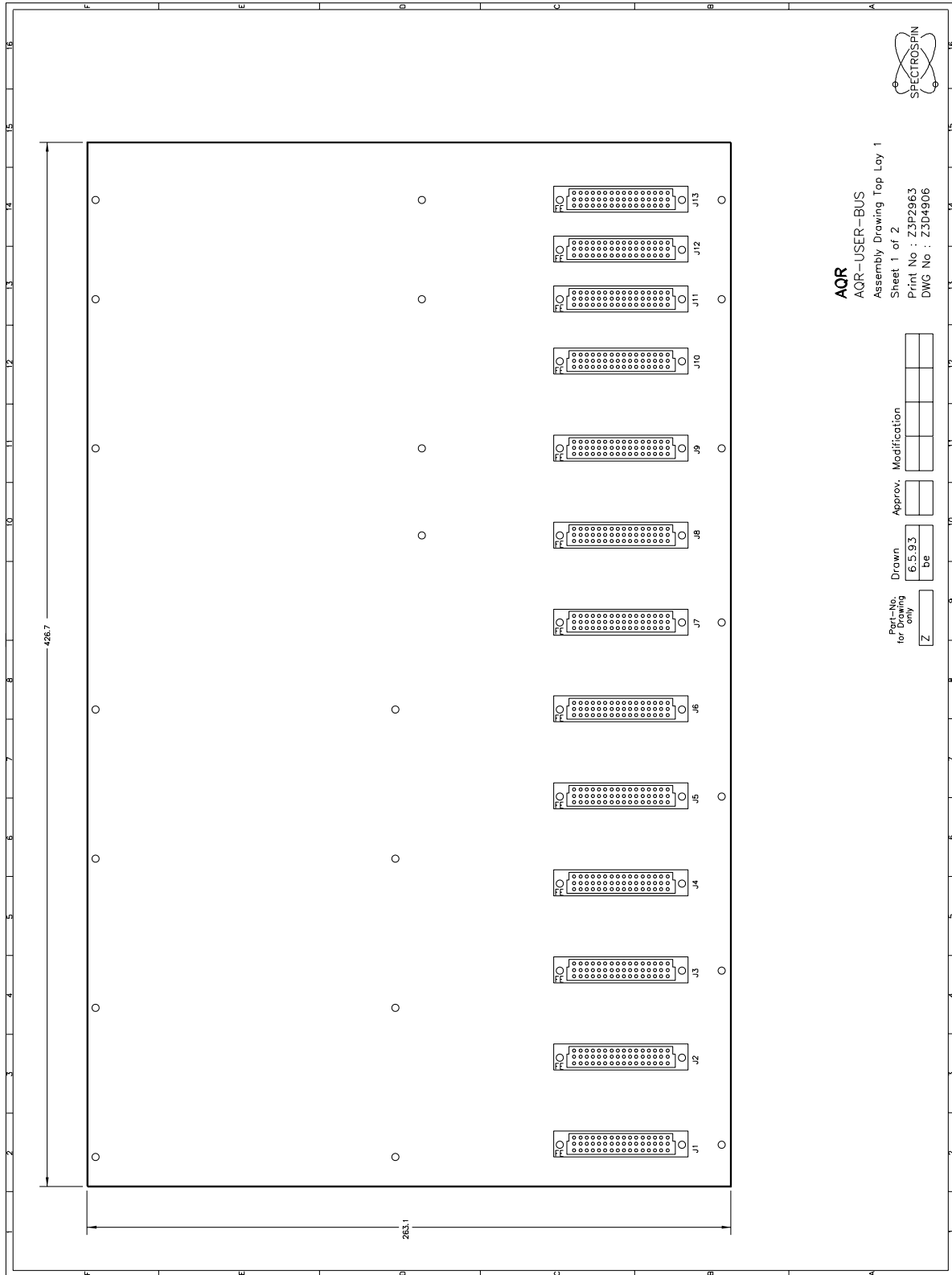

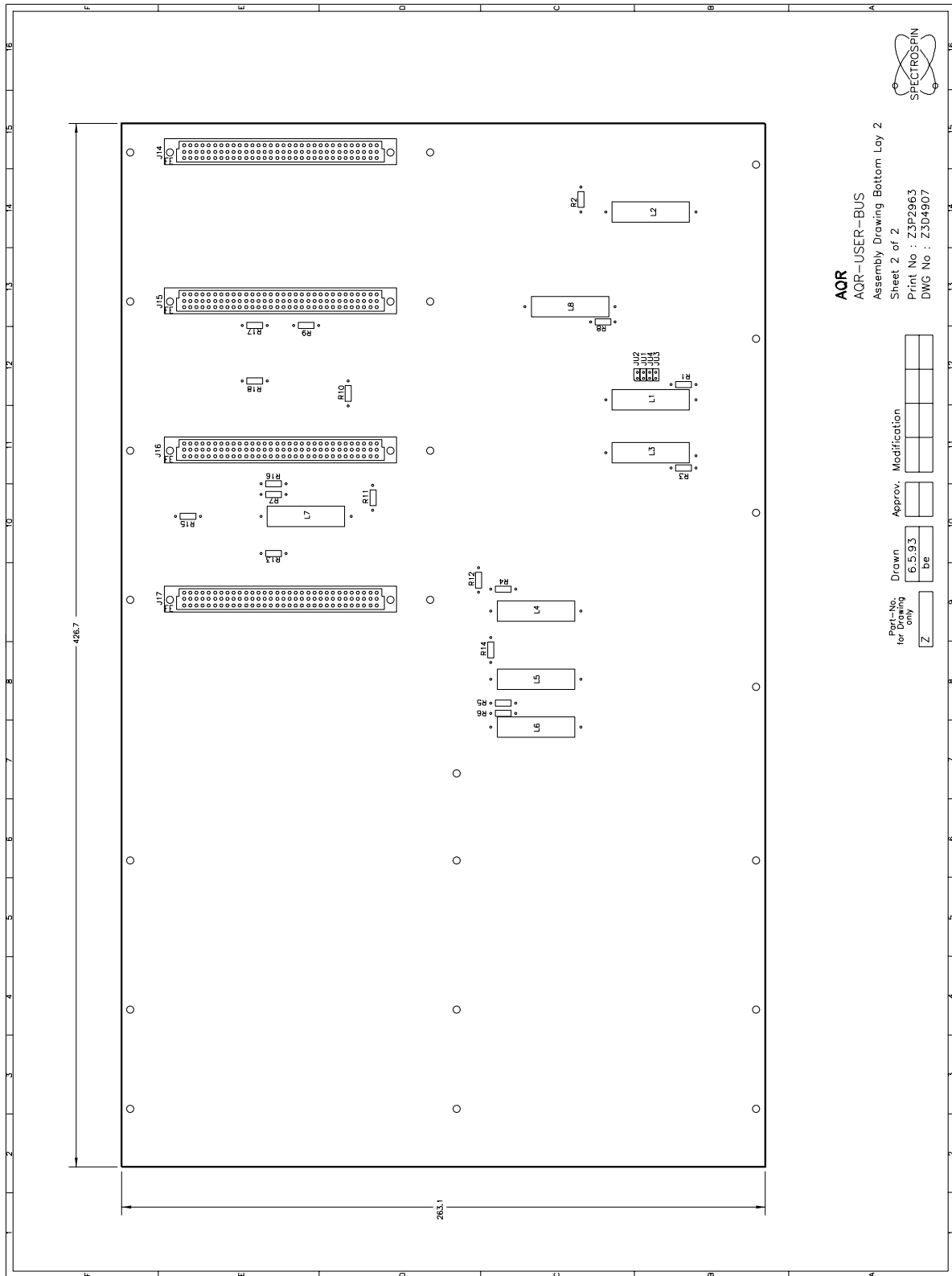

List of Index

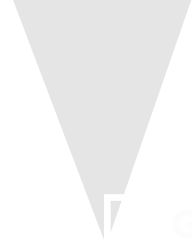

Goto

C	Control Signals	12
G	Ground Concept	11
M	Main Fuse	8
	mains selector	10
N	NTC-Resistor.....	3
O	Overview Power-Supply-System.....	11
S	Scheme Power-Supply-Adapter (PSD1)	54
	Scheme Power-Supply-Board	26
	Scheme User-Bus	58
	Scheme Wiring	24

List of Figures

Goto

1.AQR-General Description	3
2.Chassis and Bus	5
Figure 1: Front view of a complete equipped AQR	5
Figure 2: Back view of the AQR	6
Figure 3: User-Bus in the AQR (Front view)	6
3.Power Supply	9
Figure 4: Back view of the AQR	9
Figure 5: The mains selector	10
Figure 6: Starlike ground point	13
Figure 7: Frontpanel of a PSB1, PSB2 and PSB3	14
Figure 8: Frontpanel of PSD1.....	18
4.Appendix	23

List of Tables

1.AQR-General Description.....	3
2.Chassis and Bus.....	5
Table 1. I2C Address configuration	7
Table 2. Technical Data of the AQR Chassis:	8
Table 3. Technical Data of the Line Module:	8
3.Power Supply.....	9
Table 4. Rated Voltages and Currents of PSB1	15
Table 5. Rated Voltages and Currents of PSB2	16
Table 6. Rated Voltages and Currents of PSB3	17
Table 7. Pin assignment transformer-/ PSB-Connector	19
Table 8. Connector pin assignment PSD1 - -> HPPR / SE451	20
4.Appendix.....	23

