

**BSMS**

**BSMS Mainframe  
Technical Manual**

**Version 003**

---

Bruker

---

The information in this manual may be altered without notice.

BRUKER accepts no responsibility for actions taken as a result of use of this manual. BRUKER accepts no liability for any mistakes contained in the manual, leading to coincidental damage, whether during installation or operation of the instrument. Unauthorised reproduction of manual contents, without written permission from the publishers, or translation into another language, either in full or in part, is forbidden.

This manual was written by

Beat Hugelshofer and Margat Werner

© March 1997: Spectrospin AG

CH-8117 Faellanden

Updated for BASH 2.0 by W. Heiz and U. Roos - March 1997

P/N: Z31188

DWG-Nr: 859 003

# Contents

<b>1</b>	<b>General Description .....</b>	<b>3</b>
1.1	Introduction .....	3
1.2	Caution .....	3
1.3	Troubleshooting .....	3
<b>2</b>	<b>BSMS Chassis and Buses .....</b>	<b>5</b>
2.1	Introduction .....	5
2.2	Installation .....	6
2.3	VMEBus and USERBus .....	7
2.4	Technical Data .....	8
<b>3</b>	<b>Power Supply Module .....</b>	<b>9</b>
3.1	Introduction .....	9
3.2	Installation .....	12
3.3	Troubleshooting .....	14
3.4	Fuses .....	15
3.5	Technical Data .....	17
<b>4</b>	<b>Central Processing Board CPU .....</b>	<b>19</b>
4.1	Introduction .....	19
4.2	Installation .....	21
4.3	CPU Controller Section .....	21
4.4	CPU Peripheral Section .....	21
4.5	Technical Data .....	23
<b>5</b>	<b>BSMS Keyboard KBC .....</b>	<b>25</b>
5.1	Introduction .....	25
5.2	Installation .....	29
5.3	Keyboard Controller Board .....	29
5.4	Keyboard Display Board .....	29
5.5	Technical Data .....	30
<b>6</b>	<b>Buses and Wiring .....</b>	<b>31</b>
6.1	Line Modul (DC-Fan) .....	31
6.2	Chassis wiring .....	32
6.3	Bus wiring .....	33
<b>7</b>	<b>Schematics .....</b>	<b>51</b>
7.1	Power supply overview .....	51
7.2	Main Power Board (Assembly map) .....	52
7.3	Main Power Board (Scheme) .....	53
7.4	Aux Power Board (Assembly map) .....	61
7.5	Aux Power Board (Scheme) .....	62
7.6	Shim Power Board (Assembly map) .....	63

7.7 Shim Power Board (Scheme) ..... 64

**Index ..... 65**

**List of Figures ..... 67**

**List of Tables ..... 69**

## Introduction

1.1

This manual describes the mainframe or basic system of the BSMS (Bruker Smart Magnet control System). The mainframe is a modular system providing slots in which to plug the various boards that make up the BSMS.

The BSMS consists of the following hardware:

1. One chassis with two buses, wiring and line module.
2. One power supply module.
3. One CPU.
4. One BSMS keyboard (not absolutely necessary).
5. Optional BSMS function boards (e.g., SCB, SLCB,...).

The chassis and buses, power supply module, CPU, and keyboard are discussed in this manual. The optional BSMS function boards are discussed in additional manuals (e.g., Shim Manual, Sample and Level Manual,...).

## Caution

1.2

When turning on the mains switch, the load can cause an excessive start-up current, which saturates the transformer. The primary current will then exceed the fuse value. To prevent this from happening, a negative temperature coefficient resistor (NTC) is introduced in the primary path. The NTC limits the primary current in the start-up phase, but once the unit is in the normal “on” condition, the NTC is warmed up and does not limit the current.

*N.B.: Turning the mains switch off and on repeatedly will blow the mains fuse.*

## Troubleshooting

1.3

All voltages can be checked via the corresponding LED's on the front of the boards, visible from the front of the BSMS chassis (see Power Supply Fuses and Corresponding LED's on page 16). Note, however, that the LED's only indicate whether power is present or not. For troubleshooting the power supply module please see Troubleshooting on page 14.

An error on the CPU or BSMS keyboard is indicated by an error message on the BSMS keyboard and by the error LED on the CPU. The error message has the format: *E: “Error number” CPU\_ or KBC\_ “Error Text” press ‘STD BY’*. For example, *E:1 KBC\_ RS timeout. press ‘STD BY’*.

The following steps may be helpful in troubleshooting such an error:

1. Refer to the installation guide and verify that the installation was done correctly.
2. Check the power supply to verify that all the power LED's (green) are lit. The ready LED on the CPU should either be lit or blinking. The ready LED's on the BSMS function boards should be lit. If this is not the case check the power supply module (see Troubleshooting on page 14).
3. Start the BSMS Service Tool (*[bsms]* in UNIX).
4. In the service tool submenus [**6**] *'board functions CPU...'* and [**C**] *'board functions Keyboard...'* there are functions for debugging the CPU and keyboard, respectively.

The BSMS (Bruker Smart Magnet control System) chassis has two 19"-racks: the front and the back rack. These are shown in Figure 1. The front rack has 15 slots (shown in Figure 2) for boards the size of extended Eurocards. These boards are interfaced to the mother board, which contains two bus systems: a VMEBus and a specific USERBus (shown in Figure 3). The front rack can hold 12 boards with VMEBus interfaces (9×4TE, 2×12TE, 1×6TE) and 3 boards with only USERBus connections (1×4TE, 2×7TE). The back rack houses the power supply and pneumatic module.

Beneath the front rack is the line module which is responsible for the following:

1. The mains filter.
2. The mains switch.
3. The mains fuse.
4. Two fans for actively cooling the BSMS.
5. One air filter. This can be removed for cleaning during operation without switching off the BSMS.
6. The connector providing the primary voltage to the power supply module (see Power Supply Module on page 9).

Figure 1: Front and Back Racks in the BSMS (Side View)

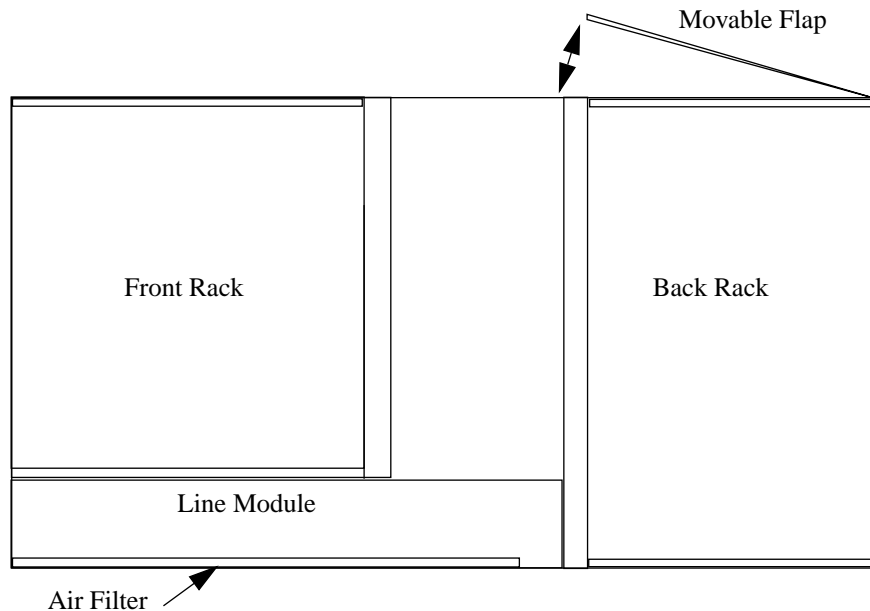
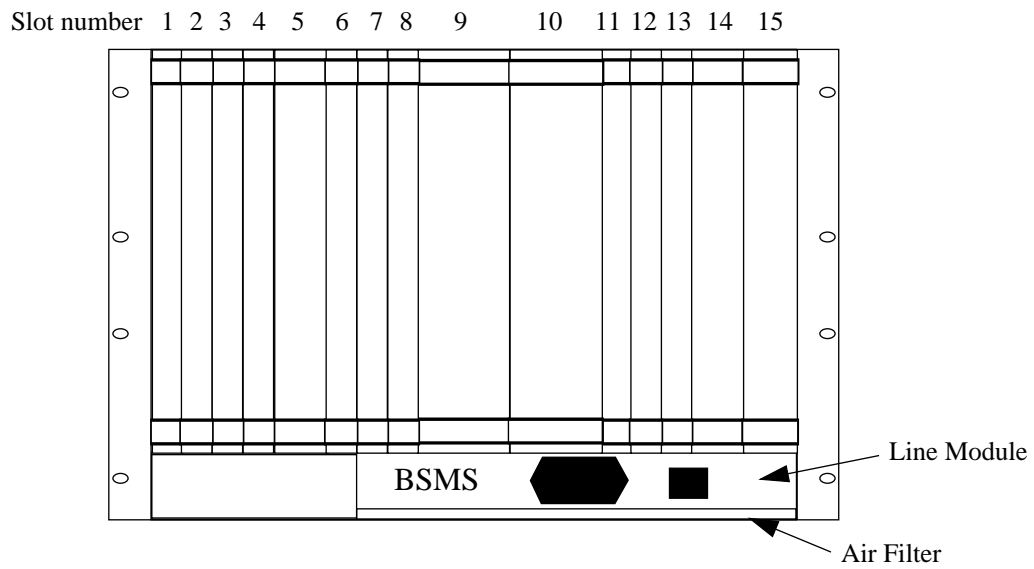

Figure 2: Slots in the BSMS (Front View)



## Installation

## 2.2

There are no special requirements for installation.



*Figure 3: VMEBus and USERBus in the BSMS (Front View)*

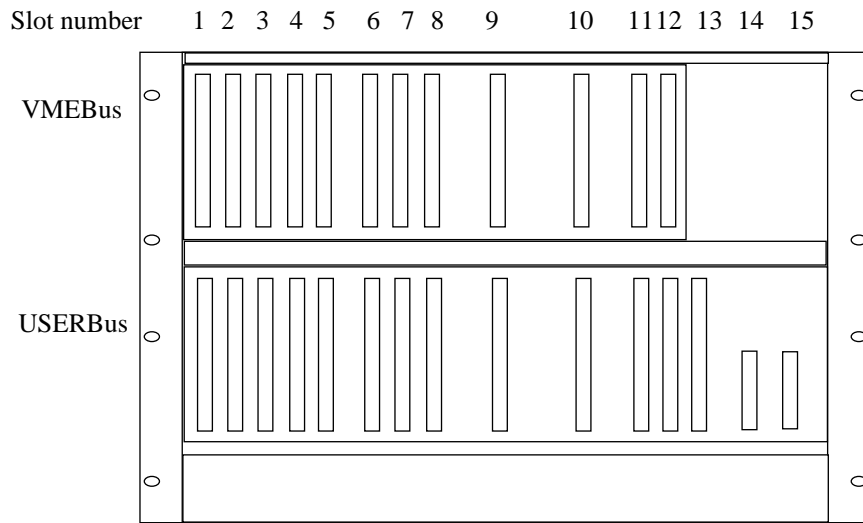

**VMEBus**

**2.3.1**

The VMEBus is a 12 slot A16/A24 D16 board corresponding to the VME standard.

**USERBus**

**2.3.2**

The USERBus is designed to route all specific signals and power supplies to the specific boards or modules. It contains the frame ground point of the BSMS. The DGND, AGND and GND24 are connected via an inductor (L1) to the frame ground (for DGND, AGND, and GND24, see also Overview of the Power Supply Module (Part One) on page 10).

**Table 1. Technical Data of the BSMS Chassis**

BSMS Chassis				
General	Height	310	mm	Dimensions are for the chassis only, without any boards or modules.
	Width	485	mm	
	Depth	500	mm	
	Weight	32	kg	For chassis equipped with 1×CPU, 1×SLCB, 2×SCB, 1×LCB, 1×L-TX, 1×R-TX, 1×power supply module, and 1×pneumatic module.
Front Rack	Board height	233.35	mm	
	Board length	220	mm	
Back Rack	Board height	277.8	mm	
	Board length	160	mm	

**Table 2. Technical Data of the Line Module**

Line Module			
Mains Fuse	4	A	time lag
Power	250	V	50...60 Hz

The power requirements of the BSMS are met by a power unit inserted in the back rack. The power unit consists essentially of three boards: the main power board, shim power board, and auxiliary power board. The transformer is fixed to the inner plate, with the regulators and rectifiers mounted on the outer plate. Wiring has been reduced to a minimum.

The mains supply may be selected to be 200 VAC, 220 VAC, or 240 VAC. This primary voltage is provided to the power supply module via the line module (see Primary Voltage Selection Switch on page 12).

The power supply module generates 12 electrically separated voltages necessary for the various BSMS functions. The wiring conduit carries the voltages to the BSMS buses (VMEBus and USERBus).

**Grounding:**

The power supply is constructed so that the different BSMS function elements (SCB, SLCB, LCB,...) have individual, electrically separate power sources. These have to be connected at designated positions (see Overview of the Power Supply Module (Part One) on page 10), thus allowing the different grounds to be joined together. On the main power board itself the lock digital and analog grounds (LOCK\_DGND, LOCK\_AGND, JU2), including the H0 ground (H0\_GND, JU1), can be connected together temporarily.

Figure 4: Power Supply Module in the BSMS (Back View)

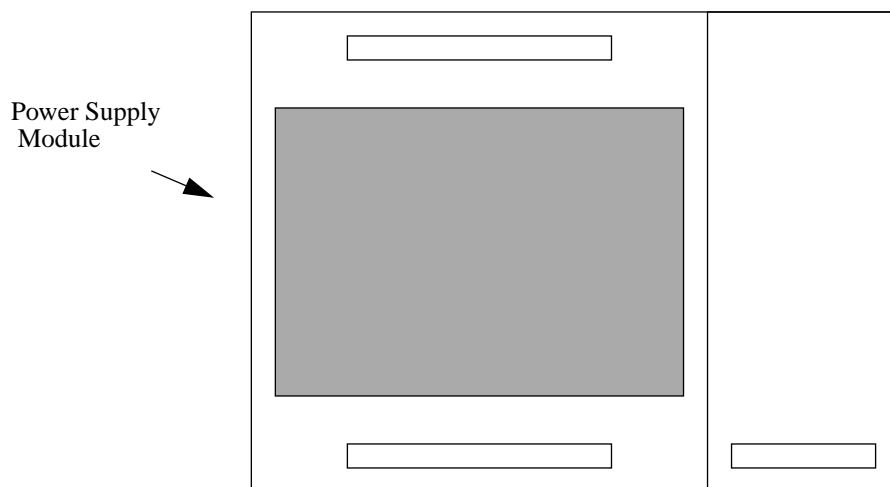

# Power Supply Module

Figure 5: Overview of the Power Supply Module (Part One)

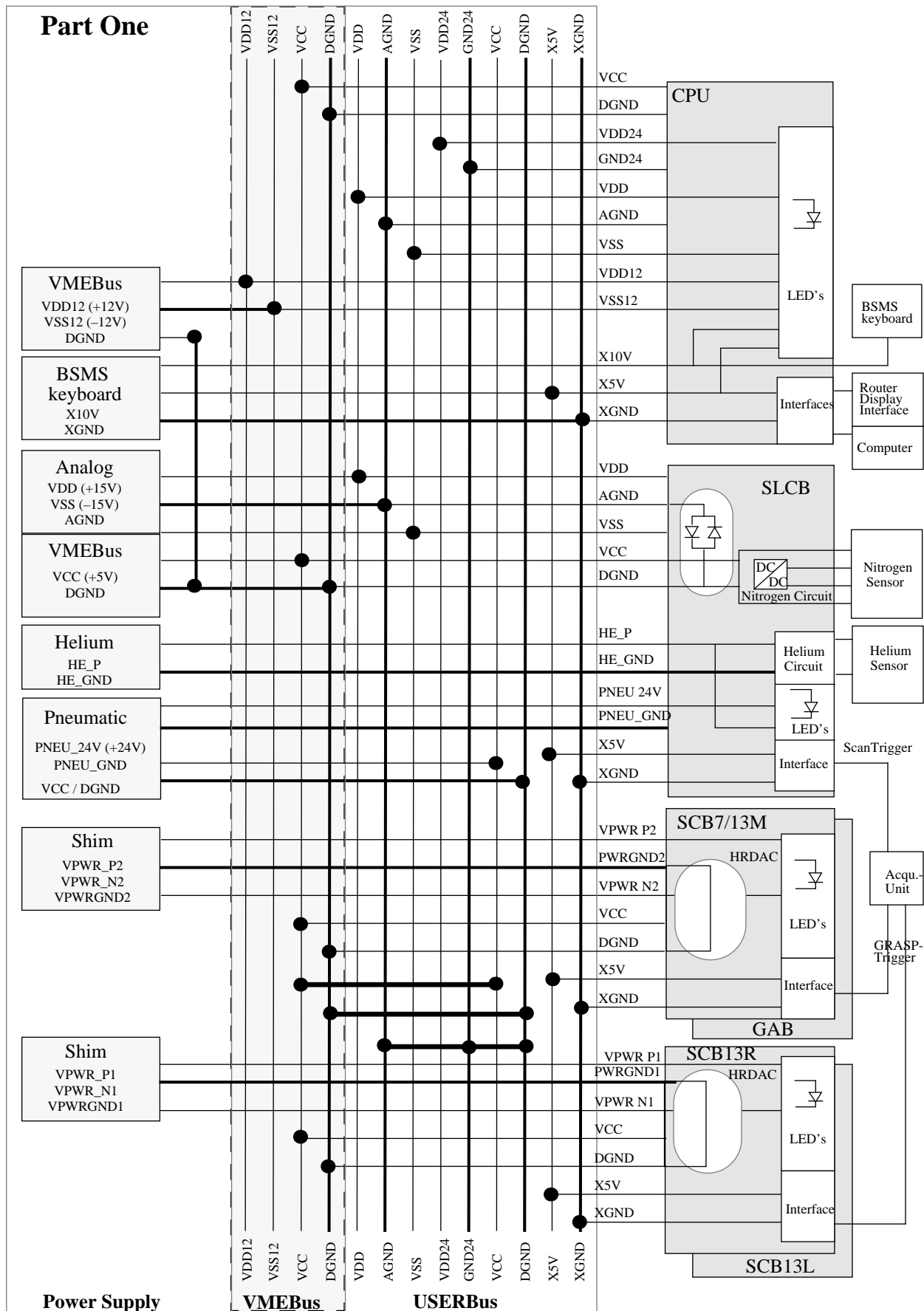
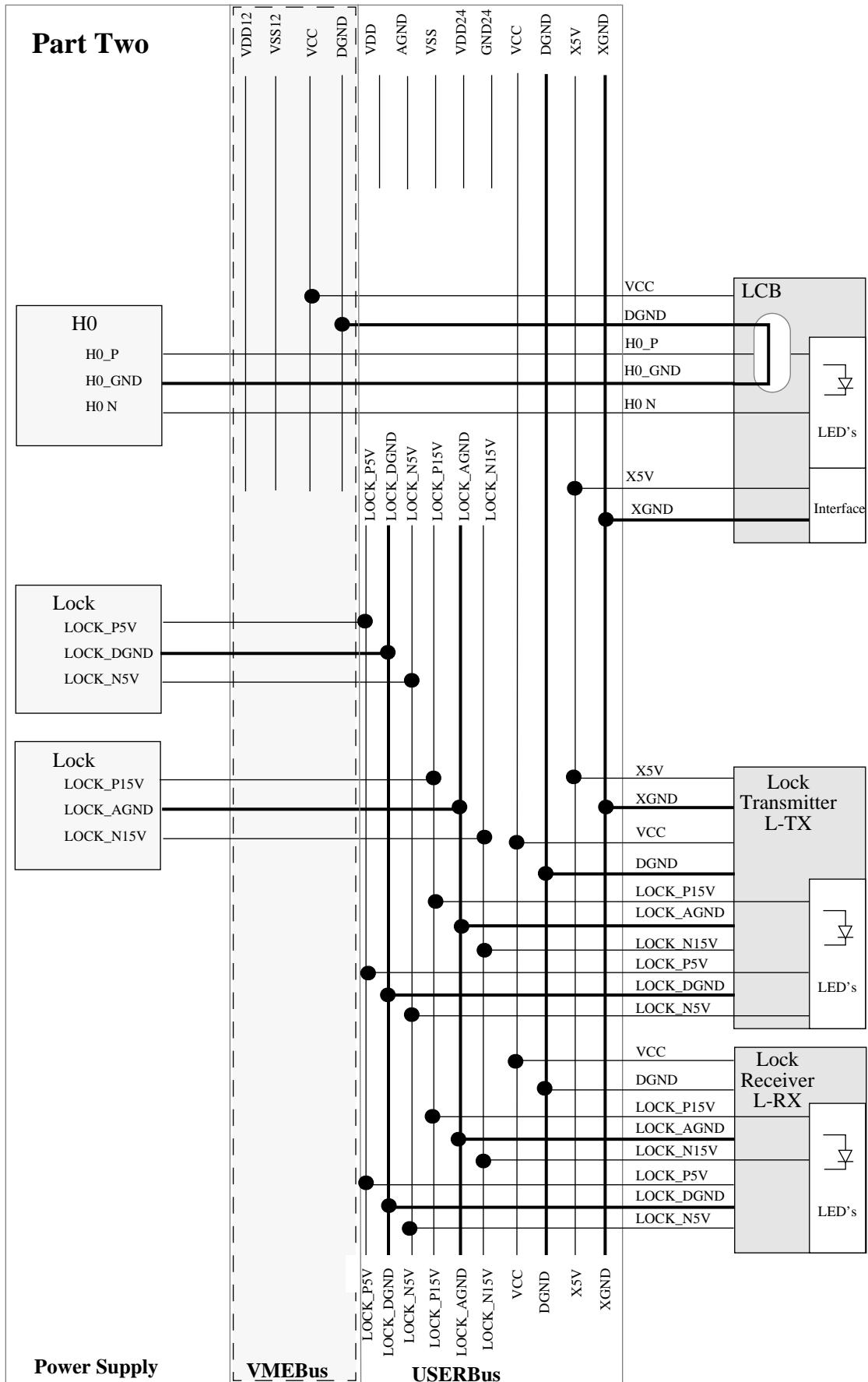

Figure 6: Overview of the Power Supply Module (Part Two)



*To install the power supply module please follow the guide below, making sure to do each step in the order given.*

1. Check that the primary voltage selection switch is in the optimal position (see the sticker on the back side of the power supply module):

The size of the power supply module is designed to minimize power dissipation; therefore, the primary voltage can be selected by the primary voltage selection switch (shown in Figure 7). Use a long screwdriver to access the switch through the hole in the rear panel. Generally, the primary voltage selection switch should be set to the next lower voltage; however, if the mains power is weak, the lowest voltage should be chosen despite the greater power dissipation (i.e., heating of the power supply module).

For Example:

230 V stable mains power  $\Rightarrow$  220 V~ position.

230 V unstable mains power  $\Rightarrow$  200 V~ position.

*Figure 7: Primary Voltage Selection Switch*

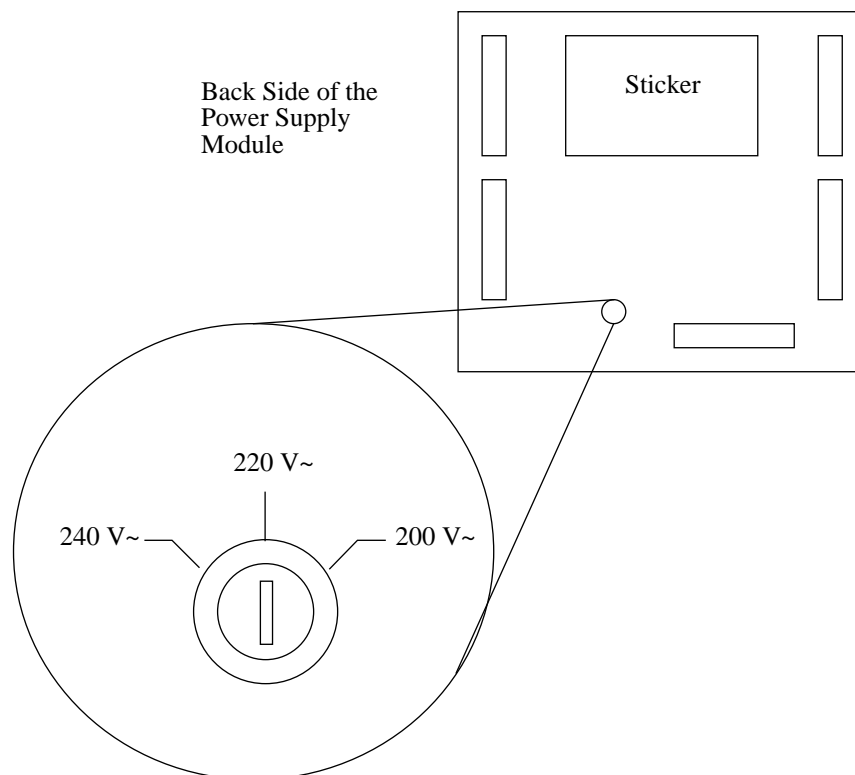

2. Insert the line module into the rack from the front (making sure that the mains cable is disconnected!).
3. Insert the power supply module into the rack from the rear. Visually check the connection between the line module and the power supply module.
4. Insert the BSMS CPU into SLOT 1 (far left of front rack). Connect the BSMS keyboard to the CPU.
5. Plug in the mains cable and turn on the BSMS.
6. Voltage LED's on the CPU should now be lit and the BSMS keyboard should run (the display should read '*Stand By*').
7. In case of a problem, switch off the power supply and check the fuses (see also Troubleshooting on page 14).

The voltages of the power supply module may be measured by the procedure outlined below:

1. Remove the power supply and line modules from the BSMS chassis.
2. Verify that the primary voltage selection switch on the power supply module is in the correct position (see Installation on page 12).
3. Connect the line module with the power supply on your desk (outside the BSMS cabinet).
4. Now connect the mains power cable and turn on the mains switch (being careful of the 220 V!).
5. Check the standby voltages on the male connectors at the back side of the power supply module. Should one or more of the voltages be missing or incorrect check the following:

Is the primary voltage selection switch set correctly?

Are the **primary and secondary fuses** in order?

If all is ok, the Power Supply Module has to be replaced by the SAG Troubleshooter.



The BSMS fuses are located on the main power board and the shim power board. To exchange a fuse open the movable flap on the top of the BSMS back rack (see Figure 1 on page 5). The sticker on the back side of the power supply module lists the types and positions of the fuses (see also Table 3 below). Two physical fuse sizes are supported:

1.  $5 \times 20$  mm
2.  $6.3 \times 32$  mm ( $\frac{1}{4}$ " x  $1\frac{1}{4}$ " )

**Table 3. Power Supply Fuses and Corresponding LED's**

Fuse name	Fuse value	Voltage	Operation Indicator (LED)
<b>Main Power Board</b>			
F1	0.63 A time lag	HE_P	SLCB (HE_30V)
F2	2 A time lag	VDD	CPU
F3	2 A time lag	VSS	CPU
F4	2.5 A time lag	X10V & X5V	CPU
F5	4 A time lag	PNEU_24V	SLCB
F6	4 A time lag	VDD24	CPU
F7	1.6 A time lag	VDD12	CPU
F8	1.6 A time lag	VSS12	CPU
F9	0.63 A time lag	H0_P	LCB (+15V, +5V)
F10	0.63 A time lag	H0_N	LCB (-15V)
F11	2 A time lag	LOCK_P15V	L-RX (+/- 15V, L-PWR), L-TX (L-PWR)
F12	2 A time lag	LOCK_N15V	L-RX (+/- 15V, L-PWR)
F13	2 A time lag	LOCK_P5V	L-TX (+/- 5V)
F14	2 A time lag	LOCK_N5V	L-TX (+/- 5V, L-PWR)
F15	16 A time lag	VCC	READY and ERROR LED's on all boards. If none are lit, VCC is defective.
<b>Shim Power Board</b>			
F2	6.3 A time lag	VPWR_N1	SCB R,L in SLOT 10,8 (VPWR_VSS)
F3	6.3 A time lag	VPWR_P1	SCB R,L in SLOT 10,8 (VPWR_VDD)
F4	3.15 A time lag	VPWR_P2	SCB M in SLOT 9 (VPWR_VDD)
F5	3.15 A time lag	VPWR_N2	SCB M in SLOT 9 (VPWR_VSS)

Regulated and non-regulated voltages are shown in Table 4 and Table 5, respectively. The following notes are applicable to both tables.

1. Voltages were measured with a true RMS DVM. The voltage ripple was determined with an oscilloscope and so gives an approximate value.
2. The rated load was provided by a resistor.
3. The standby voltage was measured at the power supply connectors (pneumatic, shim power, VME power, lock power), and the load voltage was measured at the load (cable included).

**Table 4. Regulated Voltages**

Voltage Name	Reference point	Standby mode	Current at rated load	Voltage at rated load	Voltage ripple
VCC	DGND	5.4 +/- 0.1 V	10.0 A	4.9 +/- 0.1 V	20 mV
VDD12	DGND	12 +/- 0.6 V	0.75 A	12 +/- 0.6 V	20 mV
VSS12	DGND	-12 +/- 0.6 V	0.75 A	-12 +/- 0.6 V	20 mV
H0_P	H0_GND	29.6 +/- 0.8 V	0.250 A	29.6 +/- 0.8 V	20 mV
H0_N	H0_GND	-29.6 +/- 0.8 V	0.250 A	-29.6 +/- 0.8 V	20 mV
LOCK_P15V	LOCK_AGND	15 +/- 0.7 V	1.0 A	15 +/- 0.7 V	20 mV
LOCK_N15V	LOCK_AGND	-15 +/- 0.7 V	1.0 A	-15 +/- 0.7 V	20 mV
LOCK_P5V	LOCK_DGND	5 +/- 0.1 V	1.0 A	5 +/- 0.15 V	20 mV
LOCK_N5V	LOCK_DGND	-5 +/- 0.1 V	1.0 A	-5 +/- 0.15 V	20 mV
VDD	AGND	15 +/- 0.7 V	1.0 A	15 +/- 0.7 V	20 mV
VSS	AGND	-15 +/- 0.7 V	1.0 A	-15 +/- 0.7 V	20 mV
X5V	XGND	5 +/- 0.1 V	0.5 A	5 +/- 0.15 V	20 mV

**Table 5. Non-Regulated Voltages**

*(Mains voltage: 230 VAC, Primary Voltage Selection Switch Position: 220 V~)*

Voltage Name	Reference point	Standby mode	Current at rated load	Voltage at rated load	Voltage ripple
VPWR_P1	VPWR_GND1	23.3 V	4.7 A	19.5 V	1.5 V
VPWR_N1	VPWR_GND1	-23.3 V	4.7 A	-19.5 V	1.5 V
VPWR_P2	VPWR_GND2	23.3 V	2.4 A	19.5 V	1.5 V
VPWR-N2	VPWR_GND2	-23.3 V	2.4 A	-19.5 V	1.5 V
HE_P	HE_GND	43.5 V	0.37 A	37.3 V	5 V
PNEU_24	PNEU_GND	27.5 V	1.2 A	23 V	5 V
VDD24	GND24	27.5 V	2,4 A	23 V	5 V
X10V	X10VGND	11.1 V	1.1 A	9.1 V	2 V

# Central Processing Board CPU

## Introduction

There are two different CPUs which can be used for the BSMS. They are called BSMS CPU and BSMS CPU/2. The newer BSMS CPU/2 replaces the old BSMS CPU and it is backward compatible. In the following text both CPUs will be called just as *CPU* unless there is a difference between the two boards which has to be mentioned.

The CPU is a BSMS subsystem. It plays a central role in the overall operation of the BSMS. First, it relates all messages from the computer or BSMS keyboard to the corresponding board (i.e., it serves as the master of the VMEbus). Second, it manages all functions in which more than one board are involved (i. e., autoshim,...).

The CPU is located in the left-most slot of the BSMS front rack as shown in Figure 8.

The frontpanel from the BSMS CPU/2 looks slightly differnt from the panel shown in Figure 8. Instead the seven LED for the display of the power supply there are only four LEDs on the BSMS CPU/2.

Figure 8: BSMS CPU in the BSMS

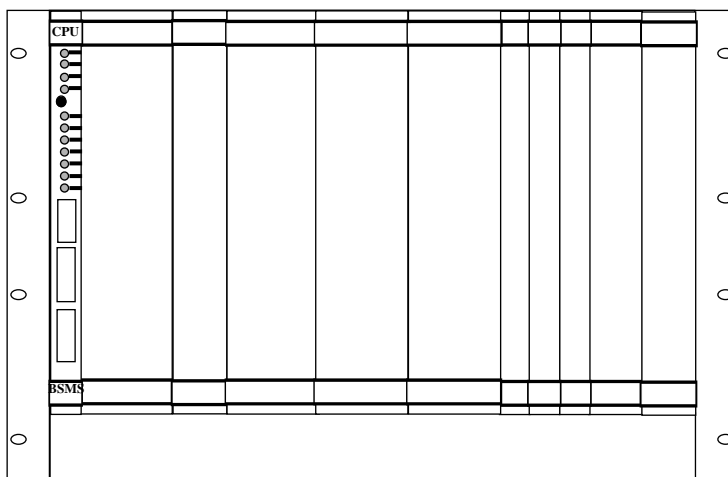

# Central Processing Board CPU

Figure 9: CPU Block Diagram

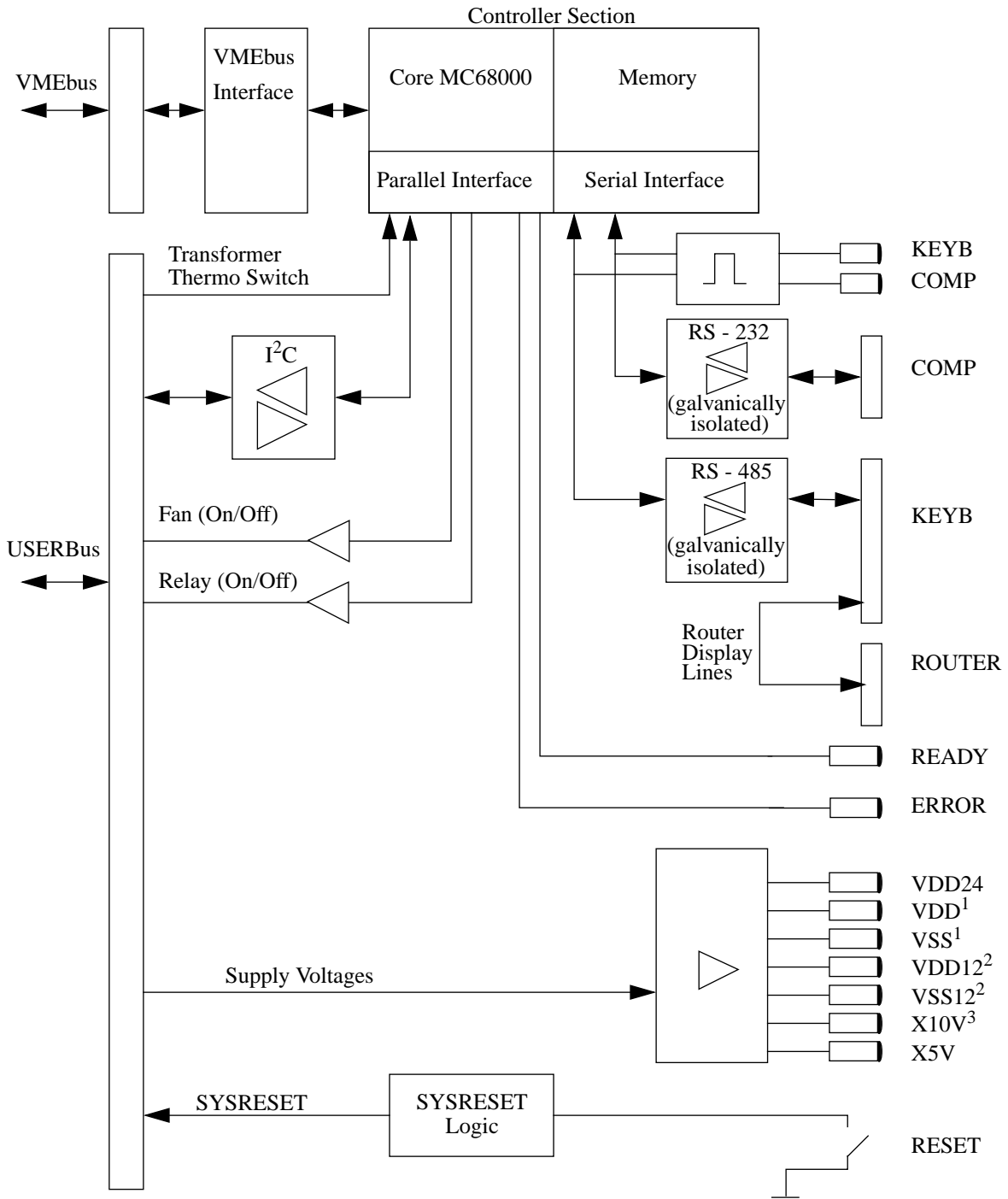

<sup>1</sup> For the BSMS CPU/2 the two LEDs *VDD* and *VSS* are replaced by one LED called +/-15V  
<sup>2</sup> For the BSMS CPU/2 the two LEDs *VDD12* and *VSS12* are replaced by one LED called +/-12V  
<sup>3</sup> The LED *X10V* is no more existant one BSMS CPU/2.

*To install the CPU please follow the guide below, making sure to do each step in the order given. No hardware adjustments are necessary for the CPU! However, PLEASE NOTE that if you exchange the CPU, stored parameters for all boards will be lost. Thus, adjustments and configurations for all boards will need to be redone. So if you replace a board do it by the helpful SERVICE features of the BSMS Tool 2.0 and later. Doing this, the whole configuration will be saved on the computer and then reloaded to the new CPU (see BSMS Service Tool: Service).*

1. Insert the CPU into SLOT 1 of the BSMS. Tighten the restraining screws.
2. Connect the RS232 cable (standard 9 pin connector cable 1:1, 22885). Also connect the BSMS keyboard and router display cable (22887, 22886), if appropriate.
3. Switch on the BSMS. After one second, check that all green LED's except the COMP and KEYB on the front of the CPU are lit or blinking. No error LED's should be lit.
4. Check the software version with the BSMS Service Tool and download the new software if necessary.

---

## CPU Controller Section

## 4.3

The Controller Section and VMEbus interface on the BSMS CPU (old CPU) is part of a OEM processor board. This board contains a complete 68HC000 Motorola processor system with parallel and serial interfaces for VMEbus.

The Controller Section on the BSMS CPU/2 (new CPU) consists of the single chip microcontroller MC68306. The MC68306 is an integrated processor containing an MC68EC000 core and parallel and serial interfaces. The VMEbus interface on the BSMS CPU/2 is realised with a programmable device and some ABT drivers.

Apart from the memory needed to run the firmware on the CPU there is a part of memory which enables the whole BSMS configuration to be saved non-volatile. The application software runs on a real time operating system and can be downloaded via the serial link to the computer (see BSMS Service Tool Manual).

---

## CPU Peripheral Section

## 4.4

The Peripheral Section handles all the BSMS special interfaces. On the BSMS CPU (old CPU) this functions are supported by an additional board called CPU-extension board.

The following funtions are supported:

1. One galvanically isolated RS232 interface for the serial link with the computer.
2. One galvanically isolated RS485 interface for the serial link with the BSMS keyboard.
3. A display of the traffic from the RS232 and RS485.
4. One I<sup>2</sup>C interface for global use in the BSMS.

5. A display of the supply voltages for the keyboard and VMEbus, and of the general purpose supply voltages.
6. System reset logic and source for the global hardware reset (SYSRESET). A reset on the CPU automatically resets all the boards but not vice versa. Only the BSMS keyboard cannot be reset. Instead, it displays an error message and after a few seconds boots automatically.
7. Supervision of the transformer temperature. The thermoswitch of the BSMS transformer is monitored by the CPU. Should the transformer overheat, an alarm sounds and an error message appears on the BSMS keyboard.
8. Different options such as fan control and programmable relay control.



Table 6. Technical Data from the CPU Controller Section

CPU Controller Section					
		BSMS CPU	BSMS CPU/2		
Features	Processor	68HC000	MC68306	Type	
	Clock	8	16	MHz	
	SRAM	64	64	kByte	
	EPROM	64	256	kByte	boot PROM
	EEPROM	64	-	kByte	non-volatile memory
	FLASH	-	256	kByte	non-volatile memory
	Timer	3	1	Units	
	Real Time Clock	1	-	Units	
	VMEbus interface	A24/A16, D8/D16	A24/A16, D8/D16	Type	
	Option I/O	12	-	TTL	General purpose I/O under software control
	Expansion Port	-	2	Units	General purpose port for CPU expansion



The BSMS keyboard is a special input/output device which allows the user quick and easy access to the spectrometer parameters that are controlled by the BSMS. This chapter describes only technical details of the keyboard. General instructions for the use of the BSMS keyboard may be found in the BSMS User's Manual.

Within the BSMS keyboard are the keyboard controller board and the keyboard display board. The keyboard controller board controls the keyboard display board, on which are placed the keys, LED's, and alphanumeric display. The router display is generally controlled by the router display controller; however, all router display functions can be operated from the keyboard controller board. This is particularly useful for the display test.

# BSMS Keyboard KBC

Figure 10: Layout of the BSMS Keyboard (Version BOSS)

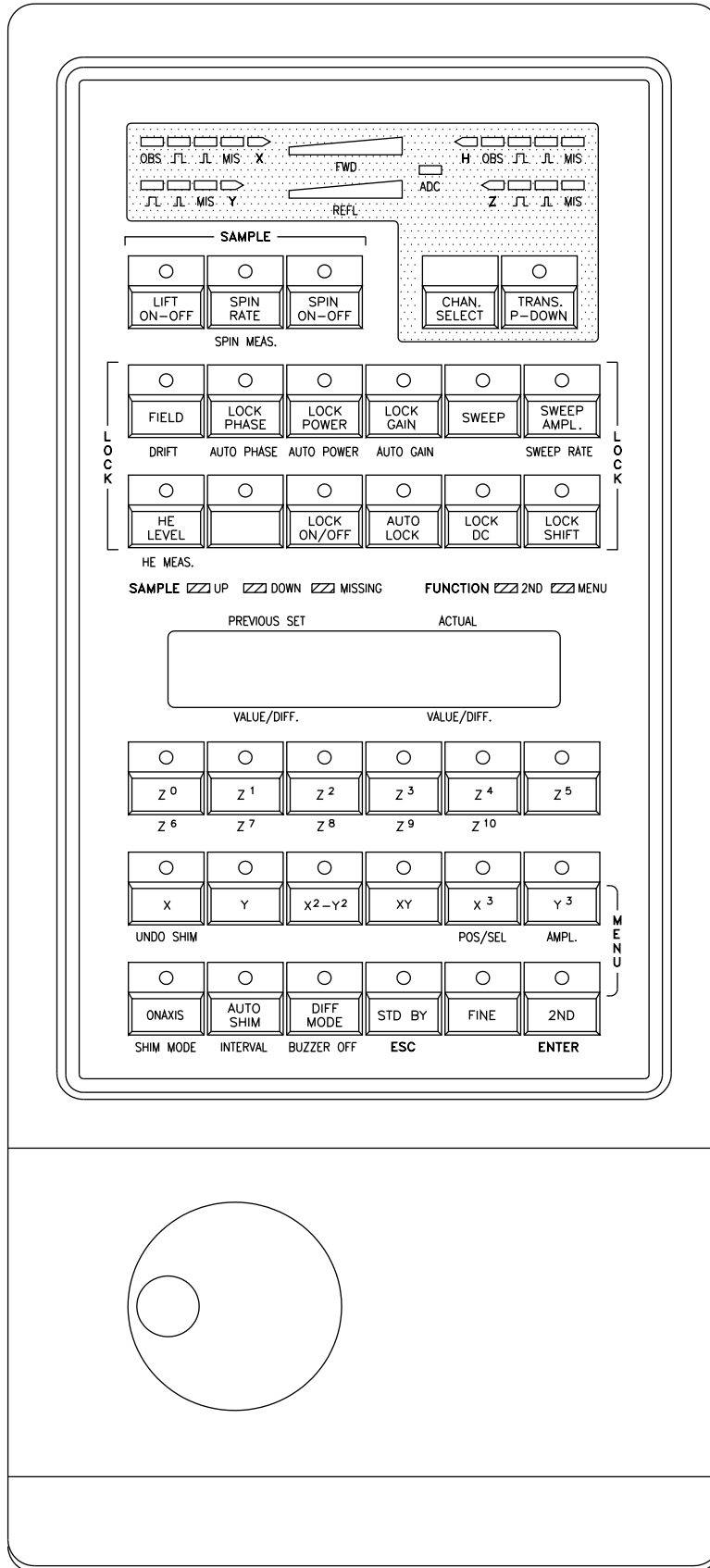
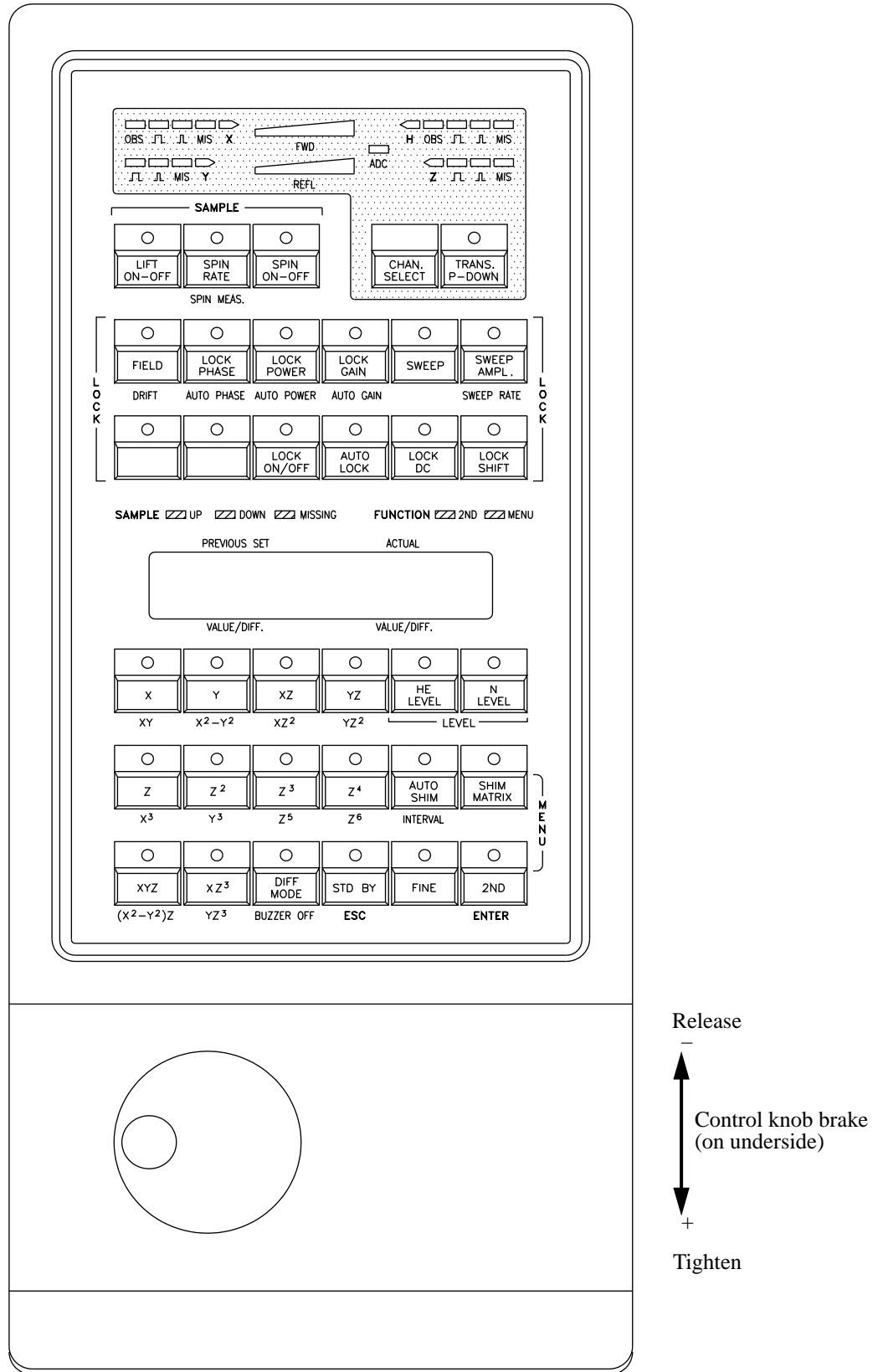
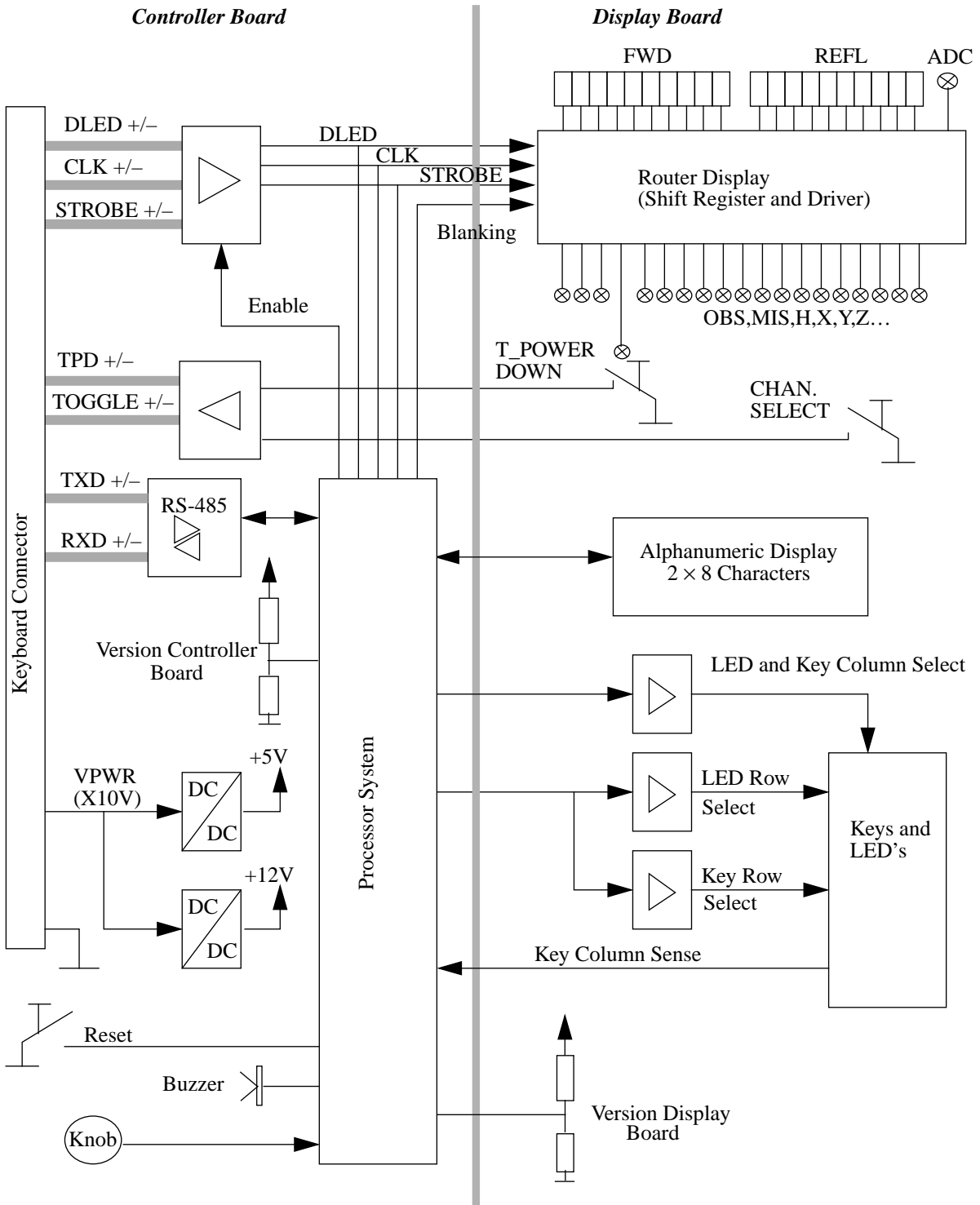

Figure 11: Layout of the BSMS Keyboard (Version HR-20)



# BSMS Keyboard KBC

Figure 12: BSMS Keyboard Block Diagram



*To install the keyboard please follow the guide below, making sure to do each step in the order given. No hardware adjustments are necessary for the BSMS keyboard!*

1. Connect the BSMS keyboard to the CPU using a standard 25 pin cable (22887).
2. Switch on the BSMS. Check that the messages '**Booting**' and afterwards '**Connecting...**' appear on the keyboard display. After approximately one second, also verify that the green KEYB LED on the CPU is blinking. No error LED's on the CPU should be lit and no error message from the keyboard (KBC) should appear on the display.
3. Check the software version with the BSMS Service Tool and download the new software if necessary.

---

## Keyboard Controller Board

## 5.3

The keyboard controller board is located in the bottom of the BSMS keyboard. It is a processor system built around a 80C535 micro-controller. The application software runs on a real time operating system and can be downloaded via the serial link with the CPU (see BSMS Service Tool Manual). The control knob and the keyboard display board are connected to the keyboard controller board.

---

## Keyboard Display Board

## 5.4

All keys, LED's with drivers, and the 2 × 8 alphanumeric display of the BSMS keyboard are placed on the keyboard display board. It is connected with the keyboard controller board by a 64 wire flat cable.

**Table 7. Technical Data of the BSMS Keyboard**

BSMS Keyboard				
Power Supply	Input Voltage	9...11	V	
	Input Current	240	mA	In Standby Mode
		1.2	A	Displaytest
Serial Link	Level	RS485 (differential)		
	Baudrate	9600	Baud	
	Data Bit	8		
	Parity	none		
	Stop Bit	1		
	Start Bit	1		









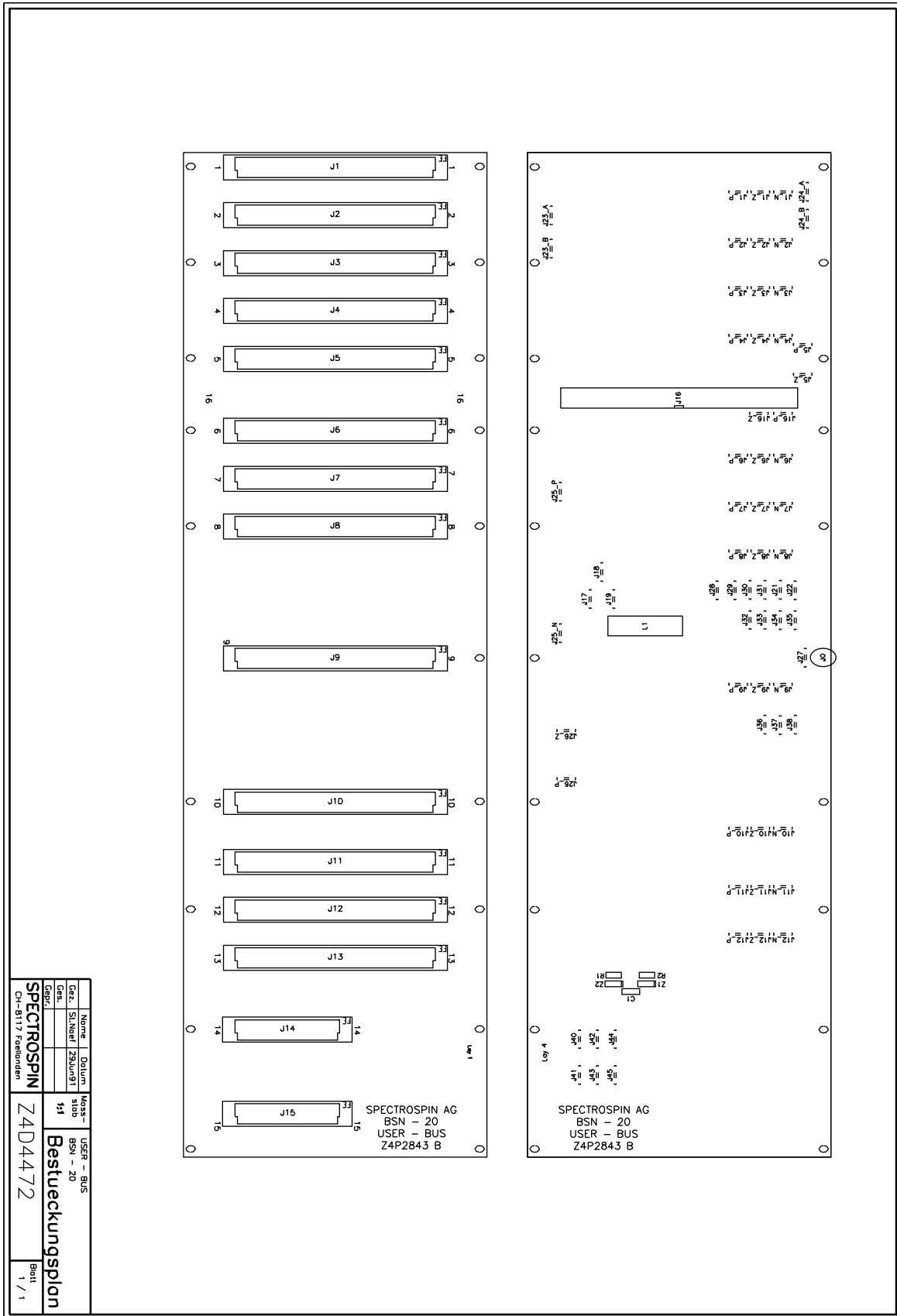

CH-8117 Faelanden	SPECTROSPIN	Z4D4472	Boett
111	Bestueckungsplan		1 / 1
141	USER - BUS		
141	BSN - 20		
141	310B		
141	NAME		
141	Datum		
141	Gez. SLM/BR		
141	ZS/BR/ST		



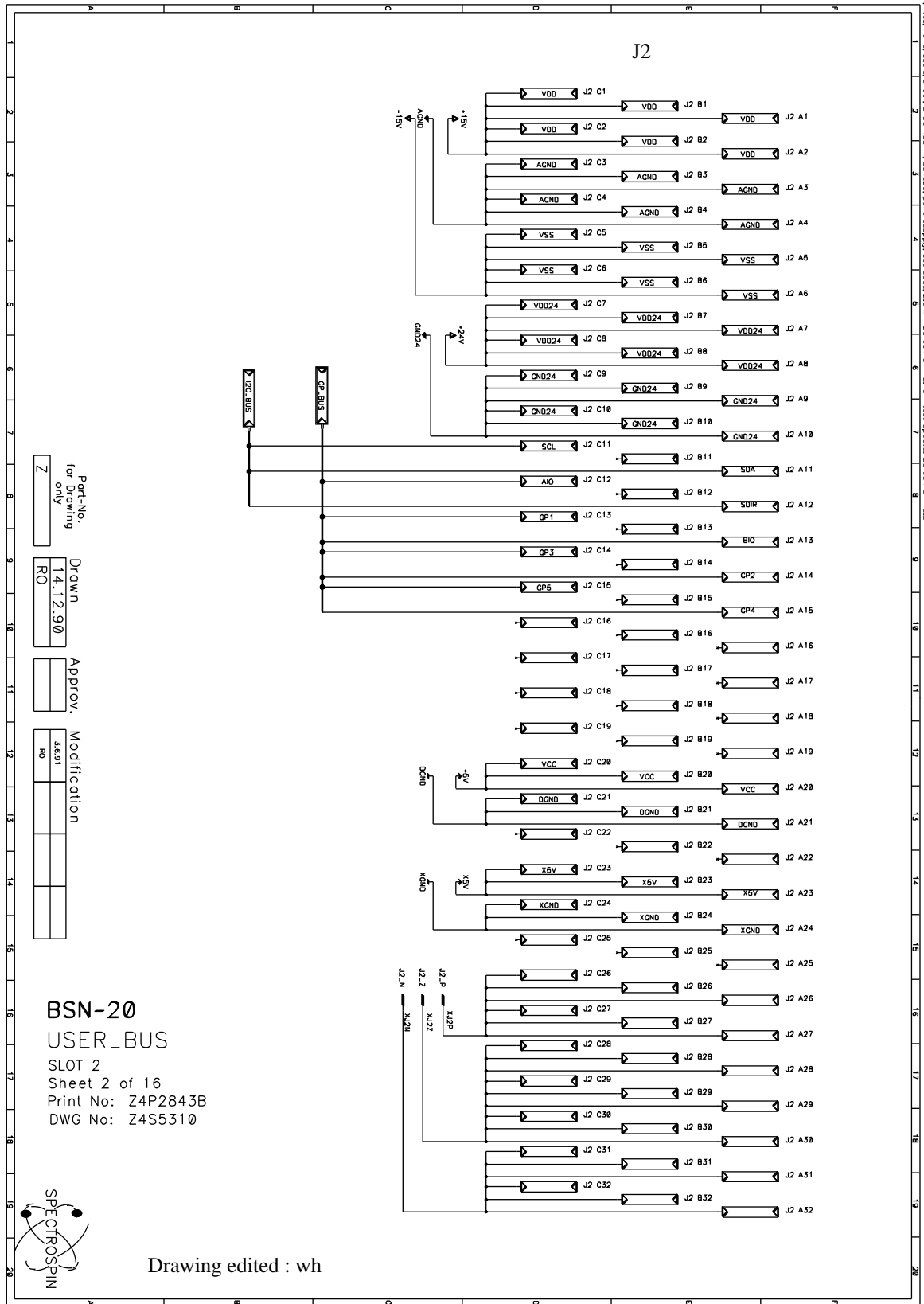

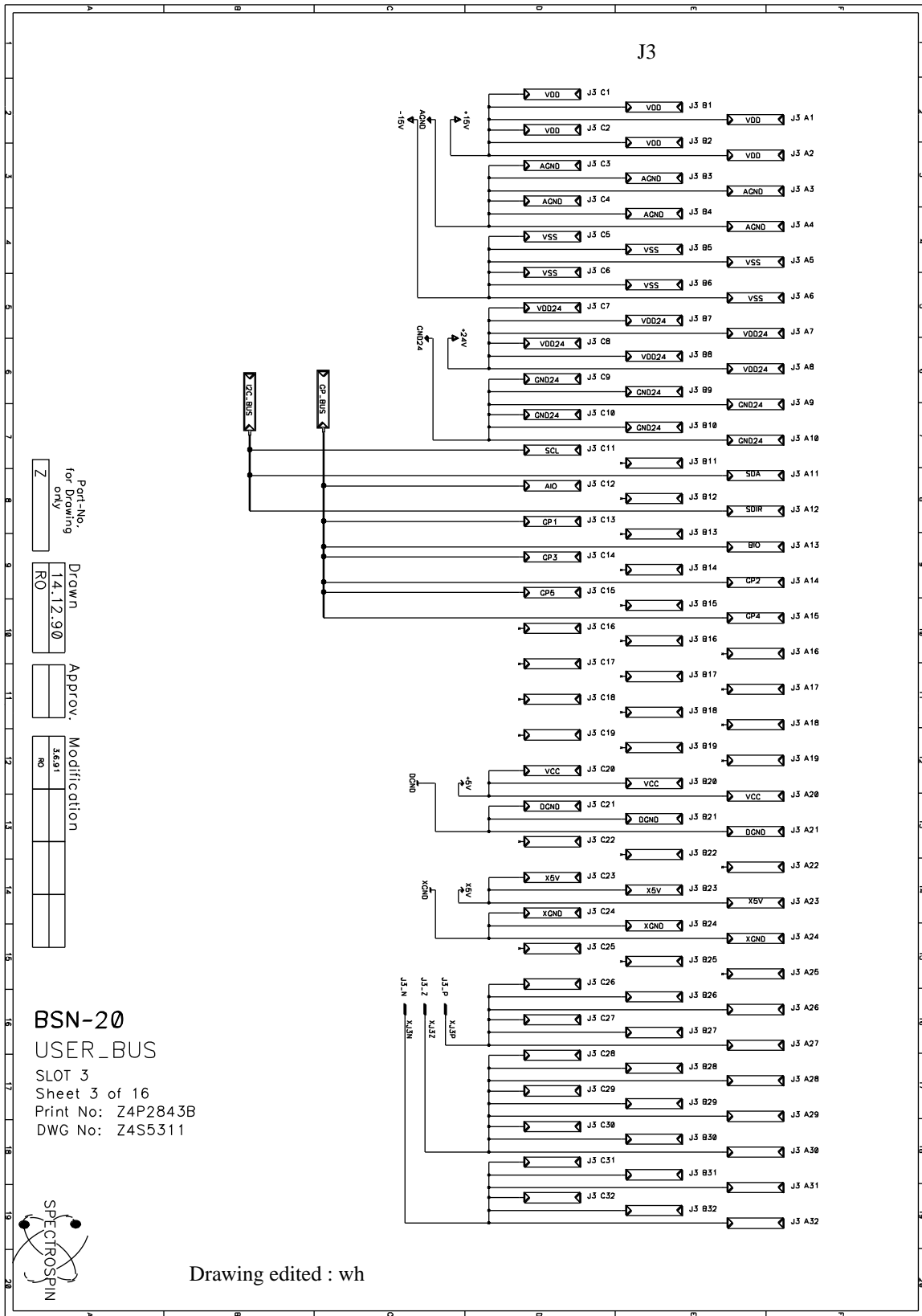

Part-No.  
for Drawing  
only

Drawn  
14.12.90  
RO

Approv.

Modification  
3.6.91  
RO

**BSN-20**  
**USER\_BUS**  
SLOT 3  
Sheet 3 of 16  
Print No: Z4P2843B  
DWG No: Z4S5311

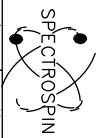

Drawing edited : wh

/Rta/home/users/anoel/SPEC/CROSPIN/BSN-20/owner\_auropl/new\_bus/3.dwg 28 JUN 91 18:44 last updated 29 JUN 91 18:25

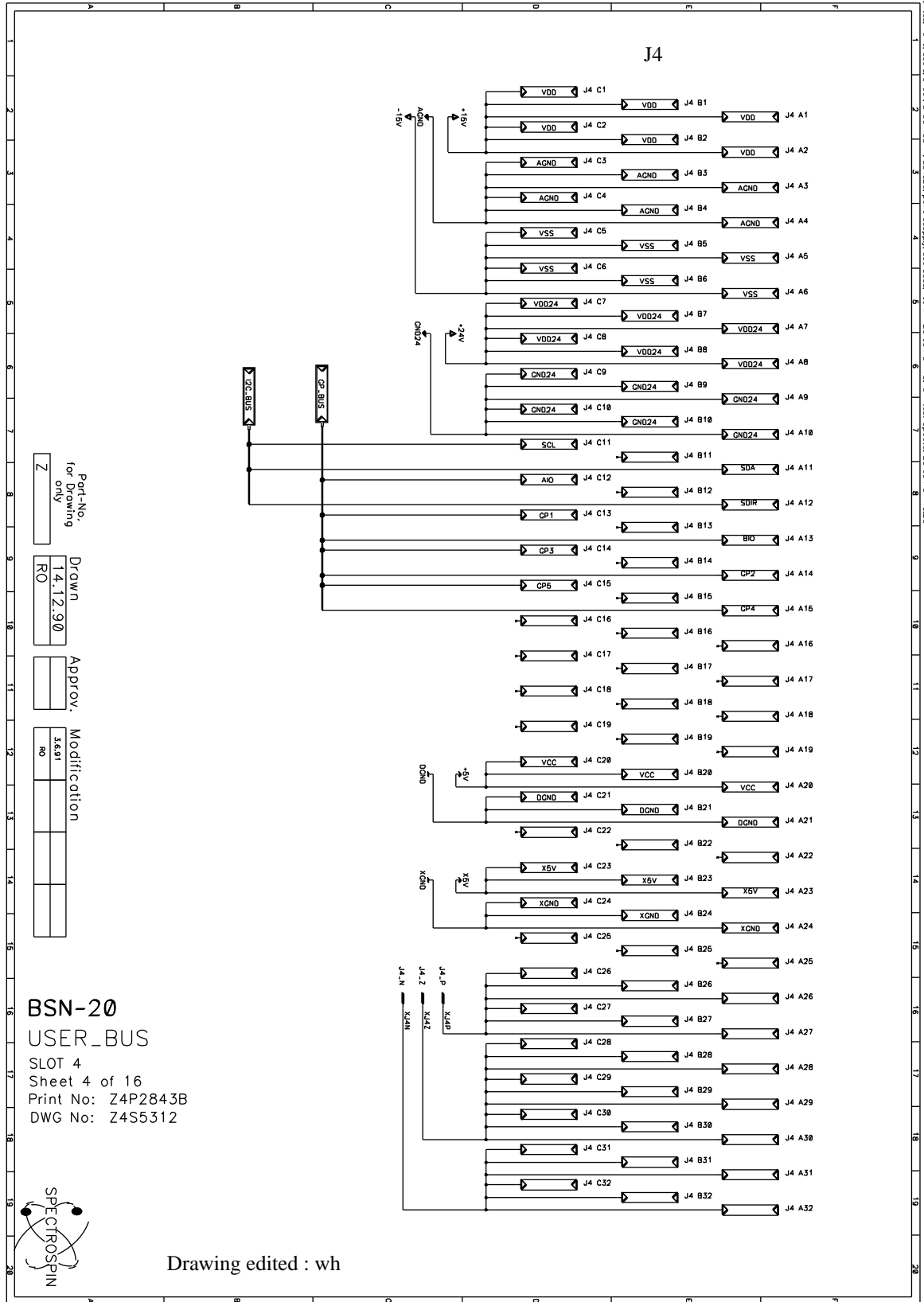



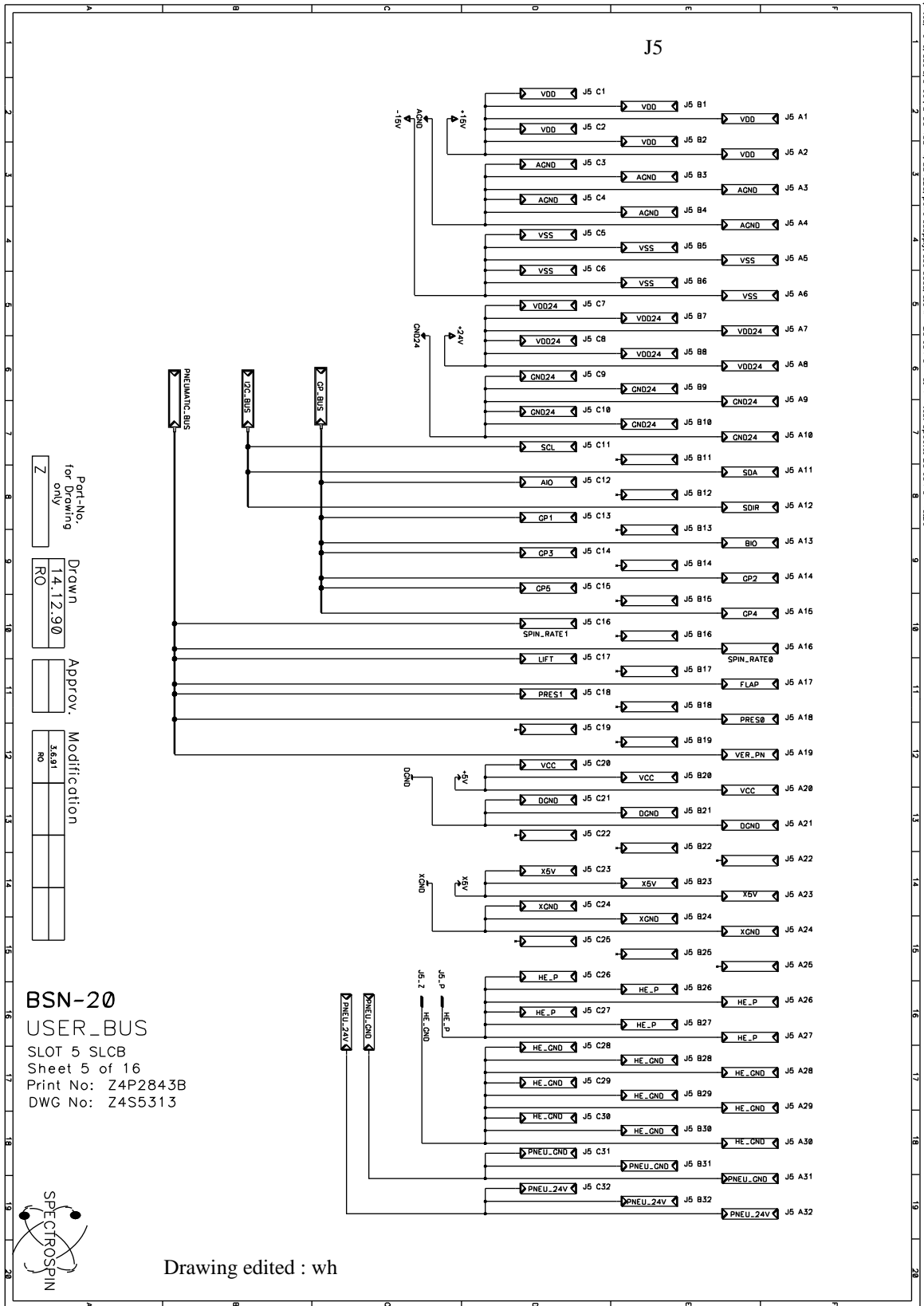

/Rim/home/users/anoel/SPEC/CIROS/SPIN/BSN-20/conv-supp/new\_bus/5.dwg 29 JUN 91 18:47 last updated 29 JUN 91 18:26

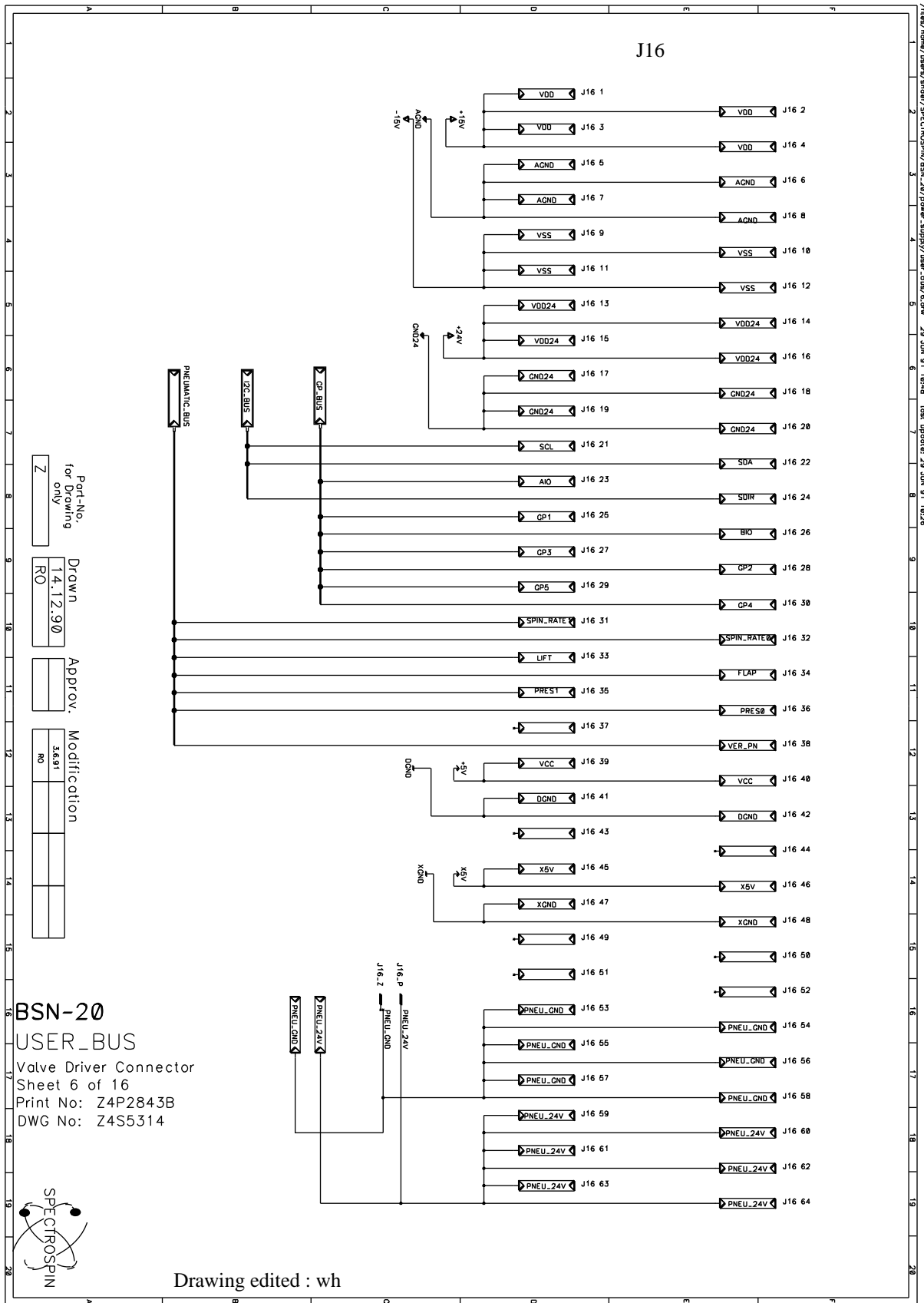

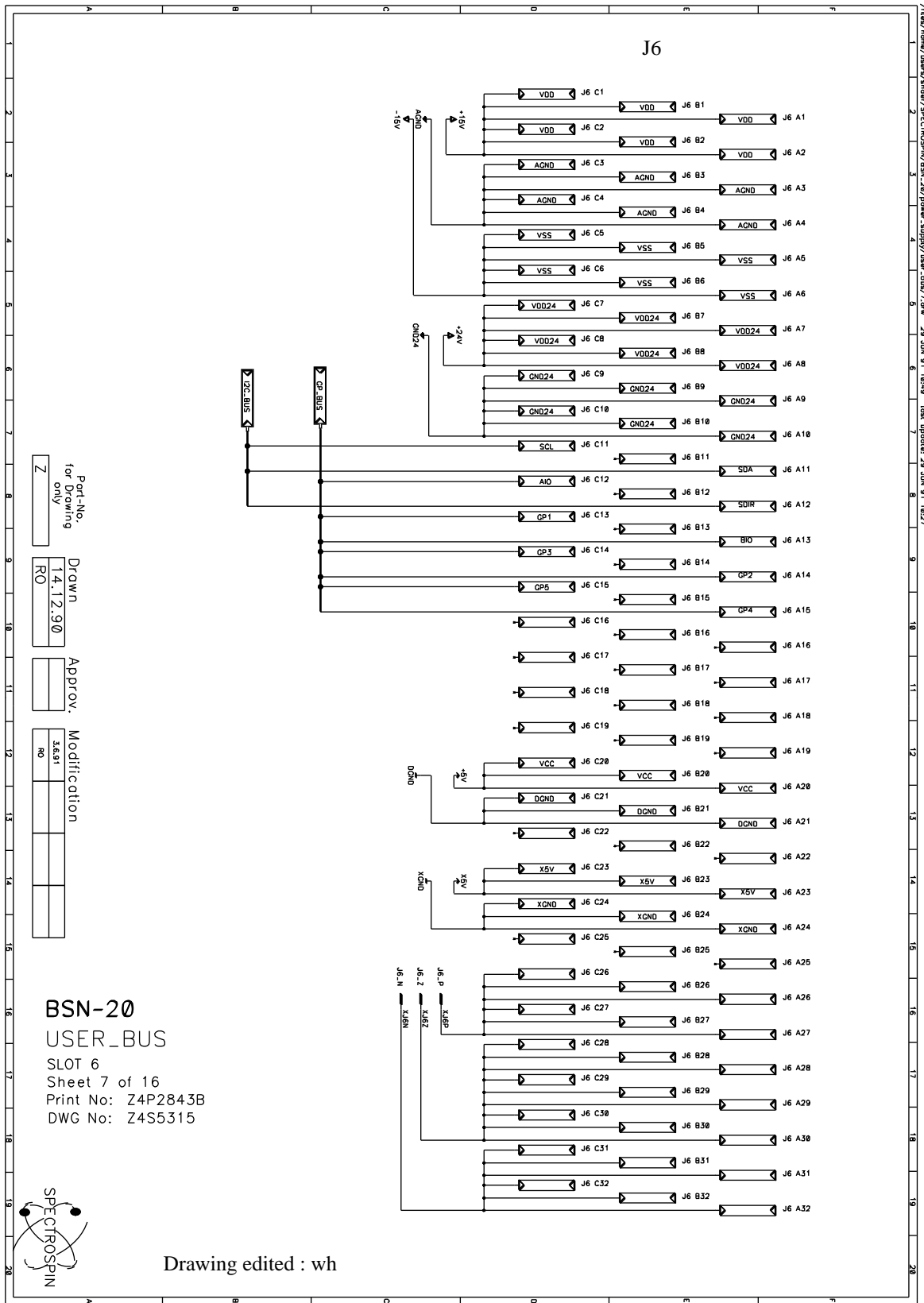

Part No.  
for Drawing  
only

Drawn  
14.12.90  
RO

Approv.

Modification  
3.6.91  
RO

**BSN-20**  
**USER\_BUS**  
 SLOT 6  
 Sheet 7 of 16  
 Print No: Z4P2843B  
 DWG No: Z4S5315

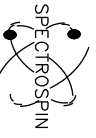

Drawing edited : wh

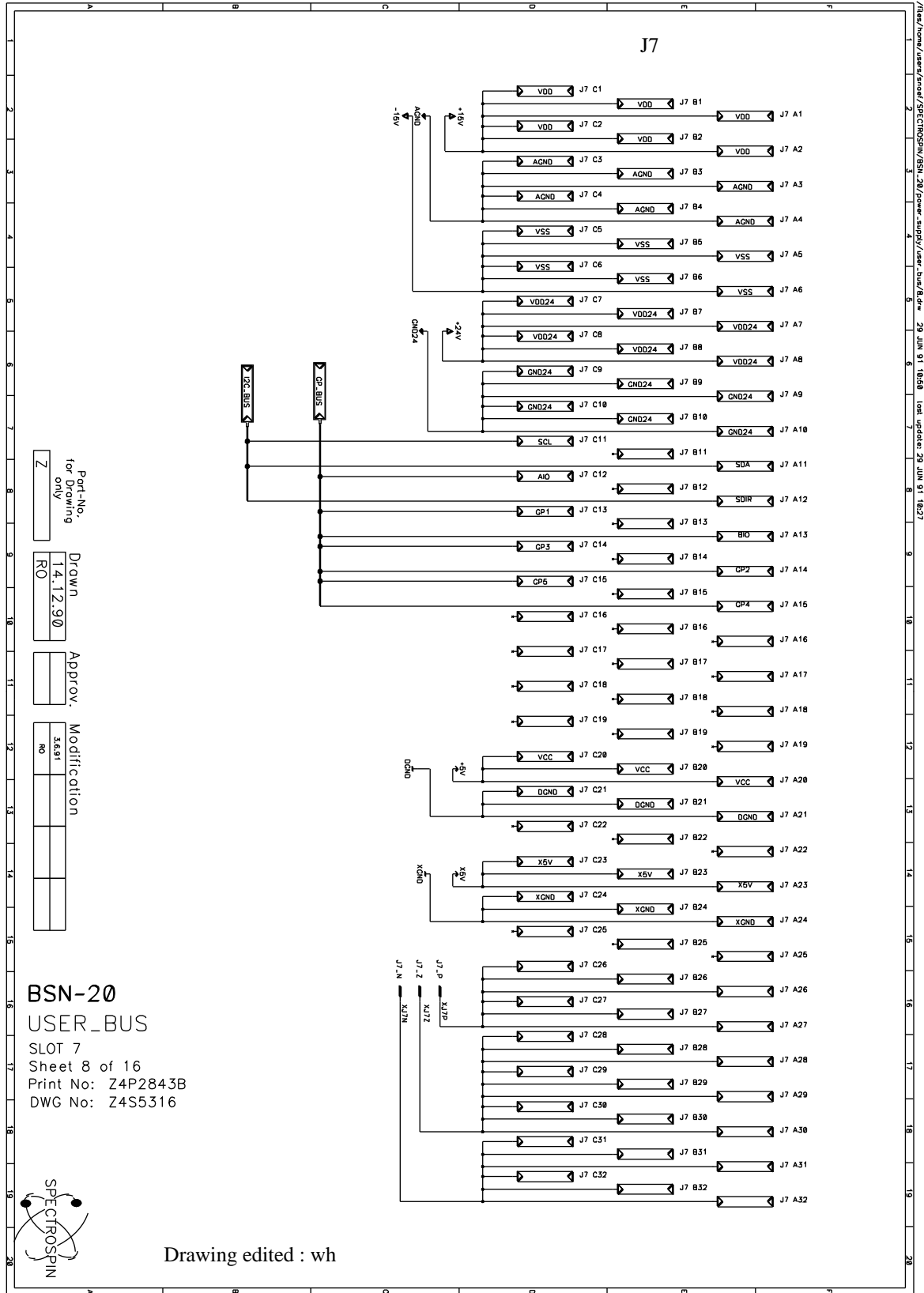

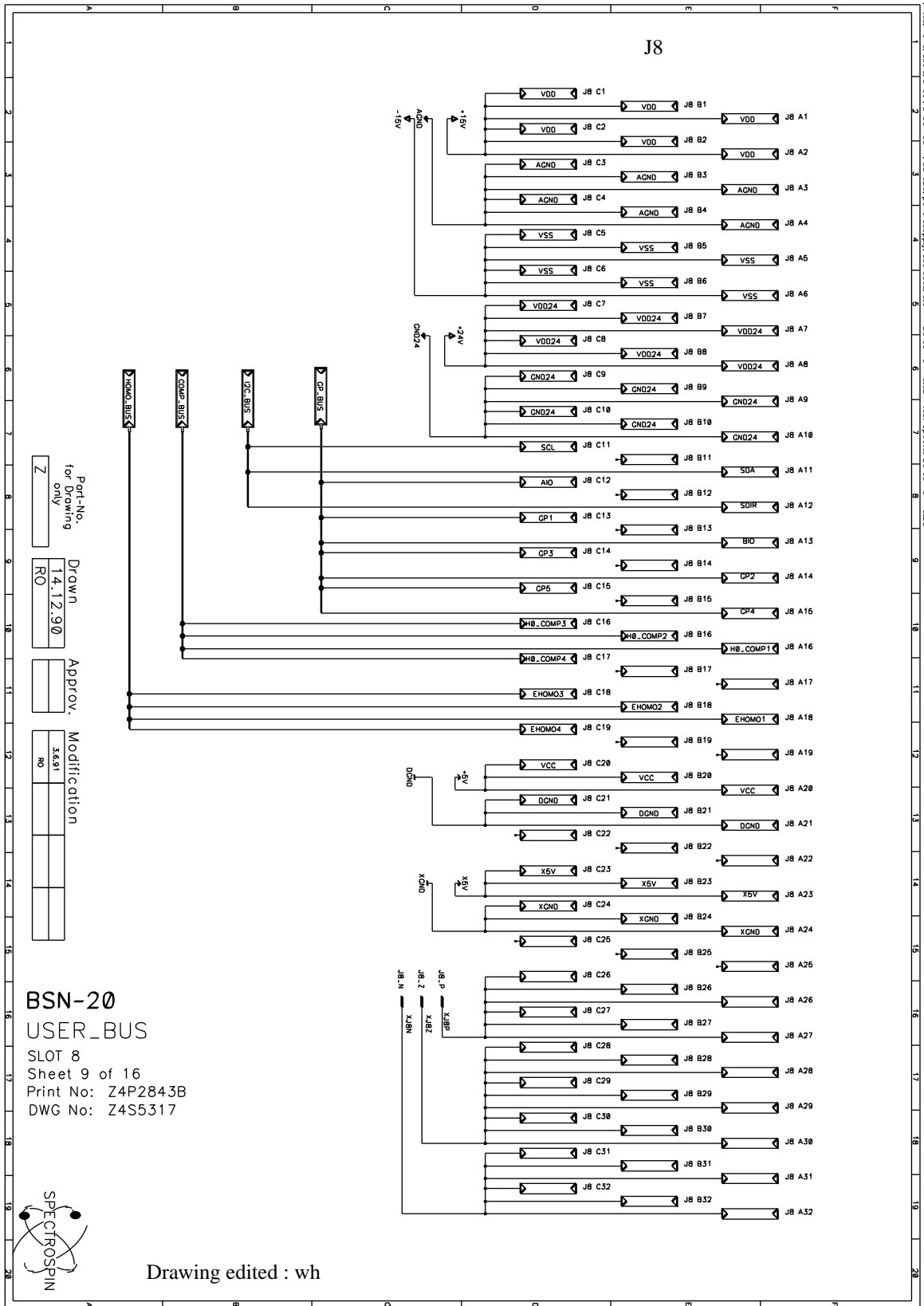

/Rim/home/users/knov/SPEC/CIOSPIN/BSN-20/cover-supply/new-bus/9.dwg 28 JUN 91 18:52 Iml:updatp 29 JUN 91 18:28

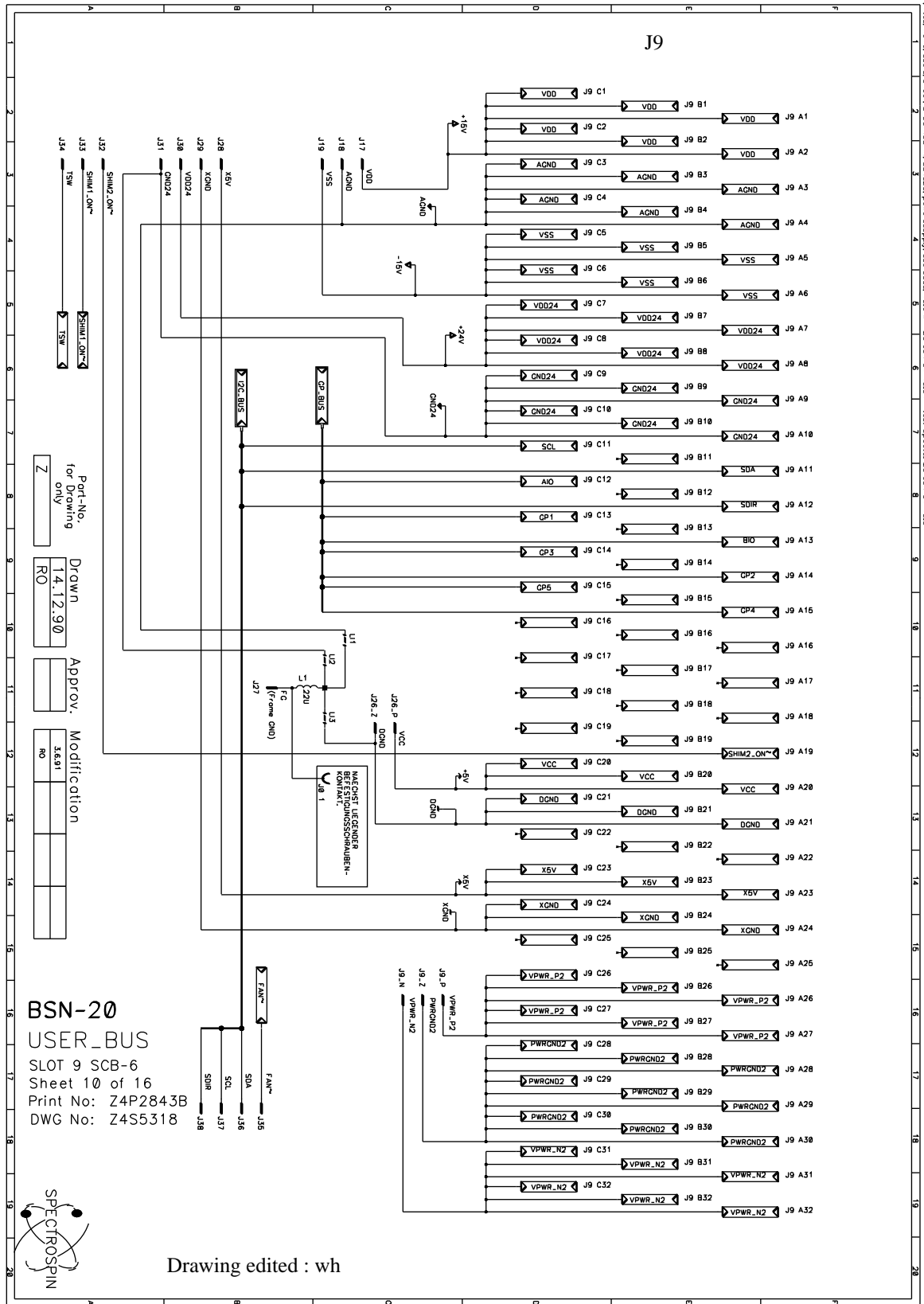

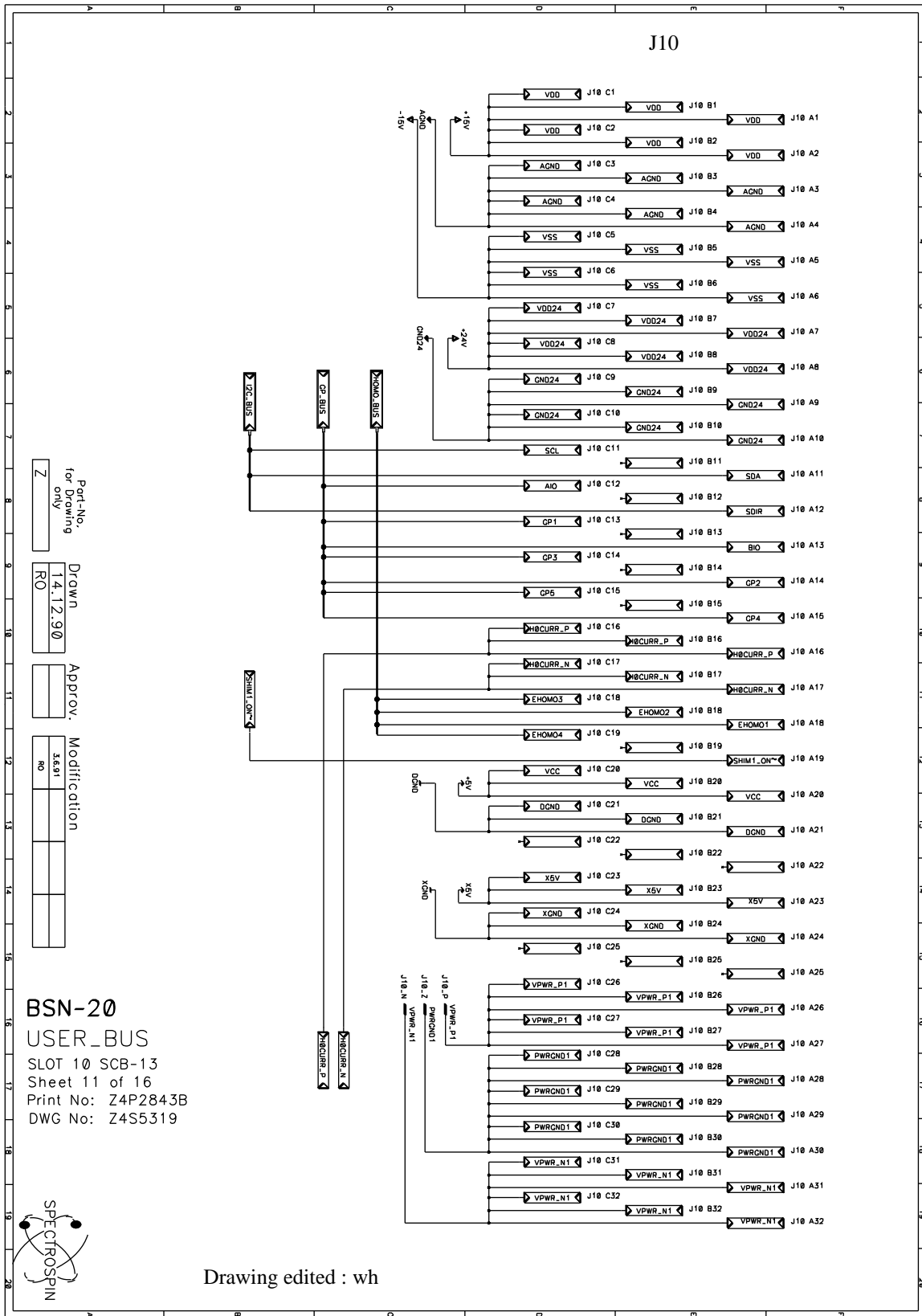

Part-No.  
for Drawing  
only

Drawn  
14.12.90  
RO

Approv.

Modification  
3.8.91  
no

**BSN-20**  
**USER\_BUS**  
 SLOT 10 SCB-13  
 Sheet 11 of 16  
 Print No: Z4P2843B  
 DWG No: Z4S5319



Drawing edited : wh

/Rim/home/users/knof/SPEC/BSN20/BSN-20/over-supply/new-hub/11.9.90 29 JUN 91 18:55 last update: 29 JUN 91 18:29

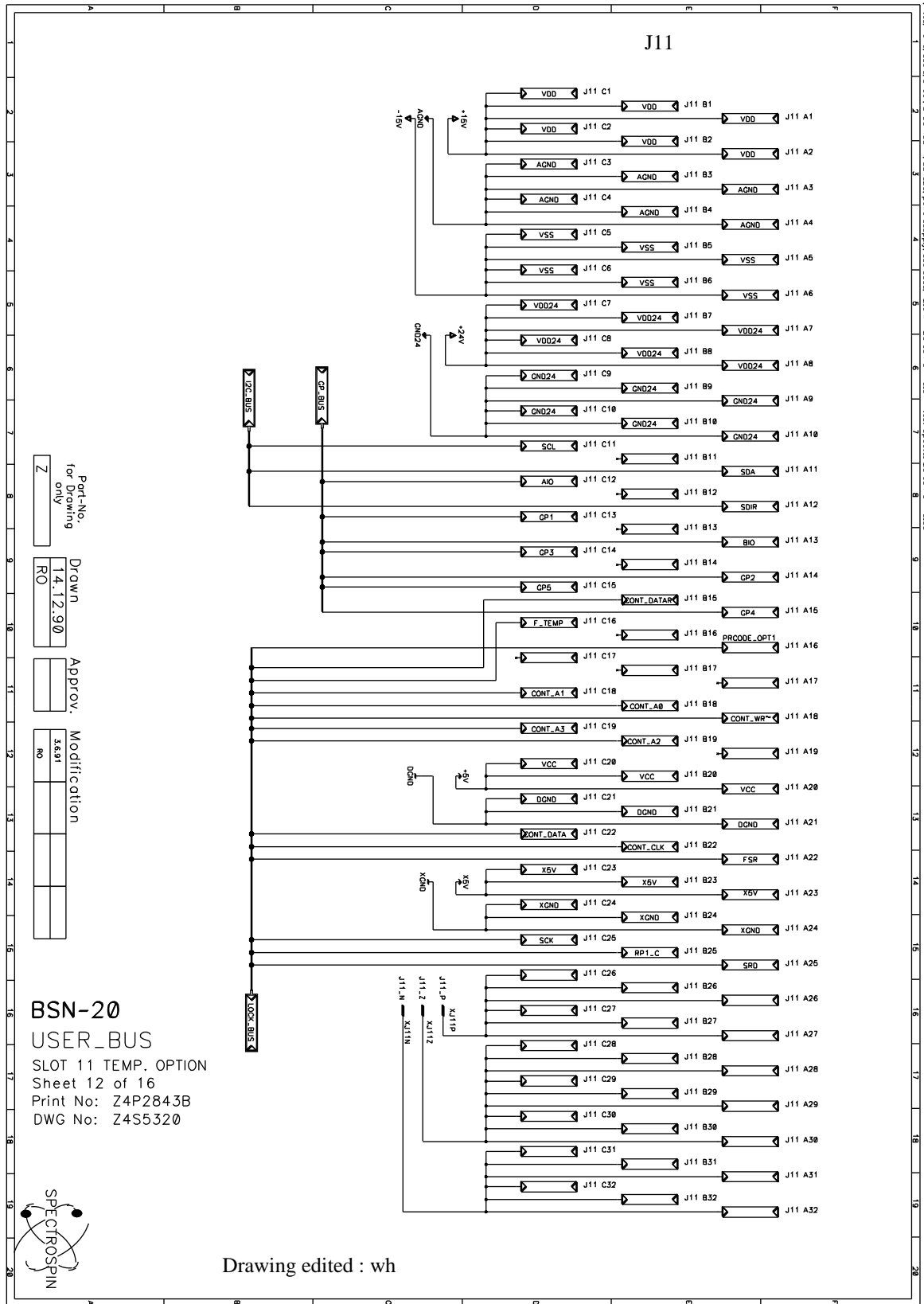





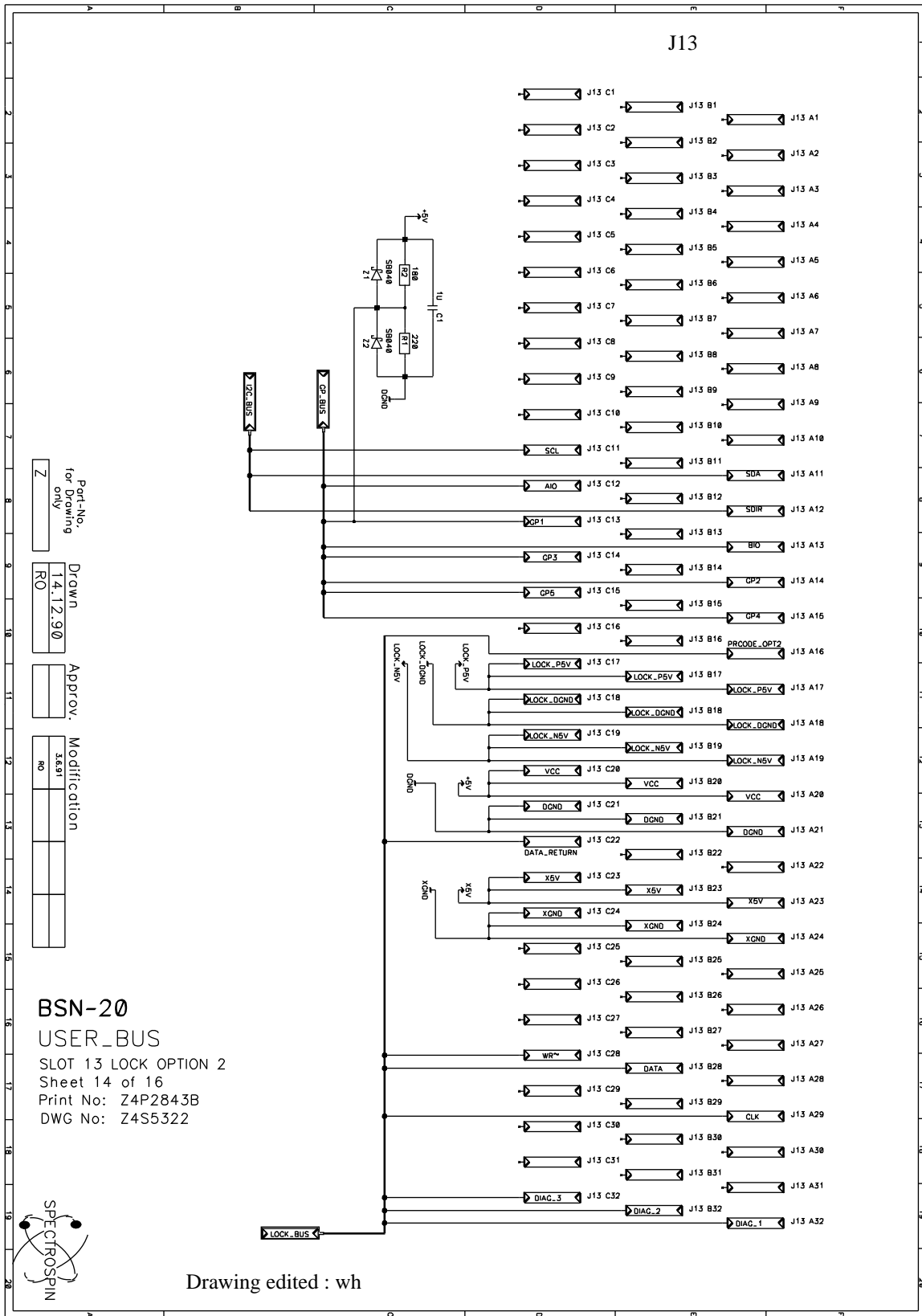

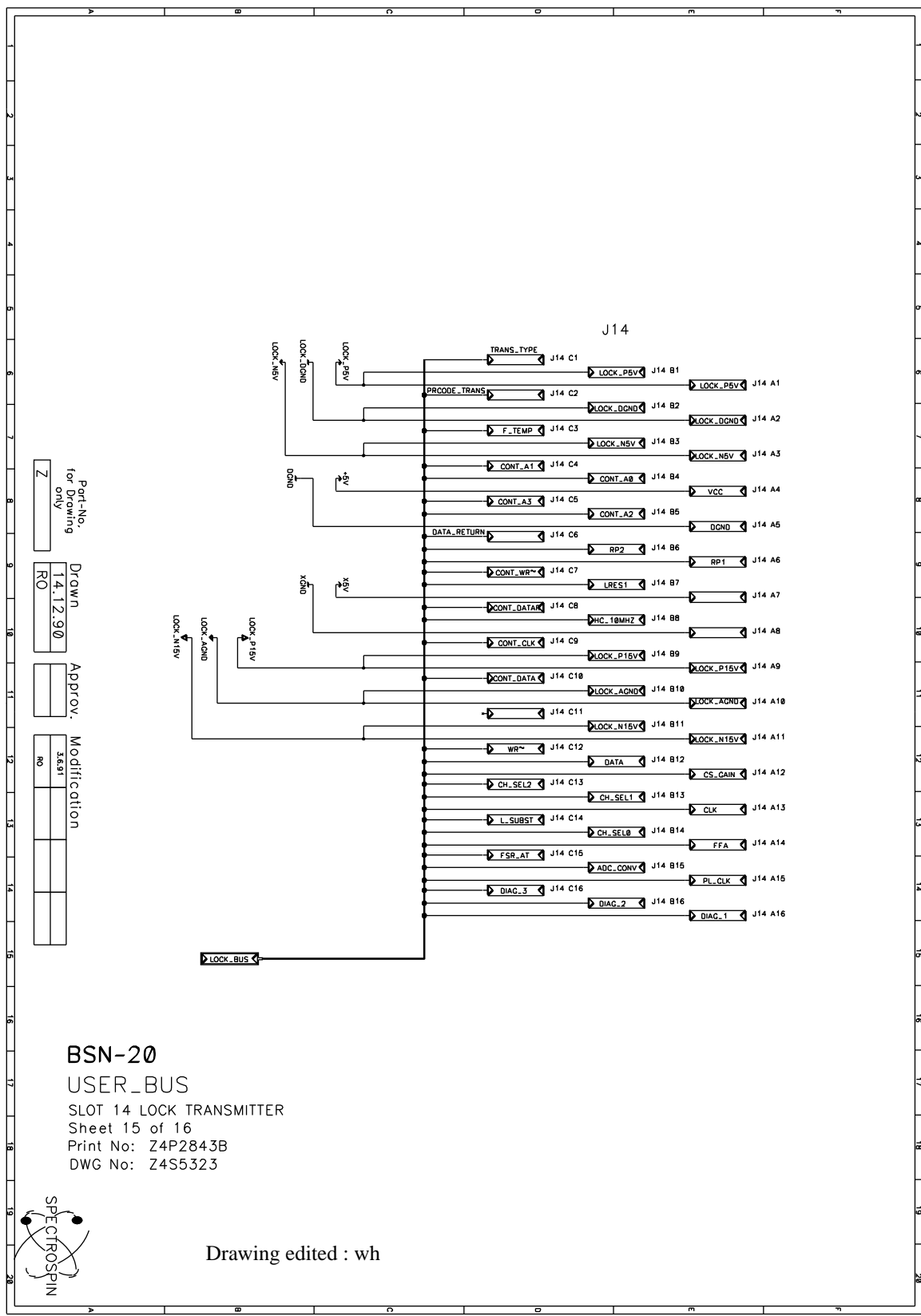

Part-No.  
for Drawing  
only

Drawn  
14.12.90  
RO

Approv.

Modification  
3.6.91  
RO

**BSN-20**  
**USER\_BUS**  
 SLOT 14 LOCK TRANSMITTER  
 Sheet 15 of 16  
 Print No: Z4P2843B  
 DWG No: Z4S5323

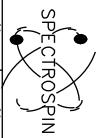

Drawing edited : wh

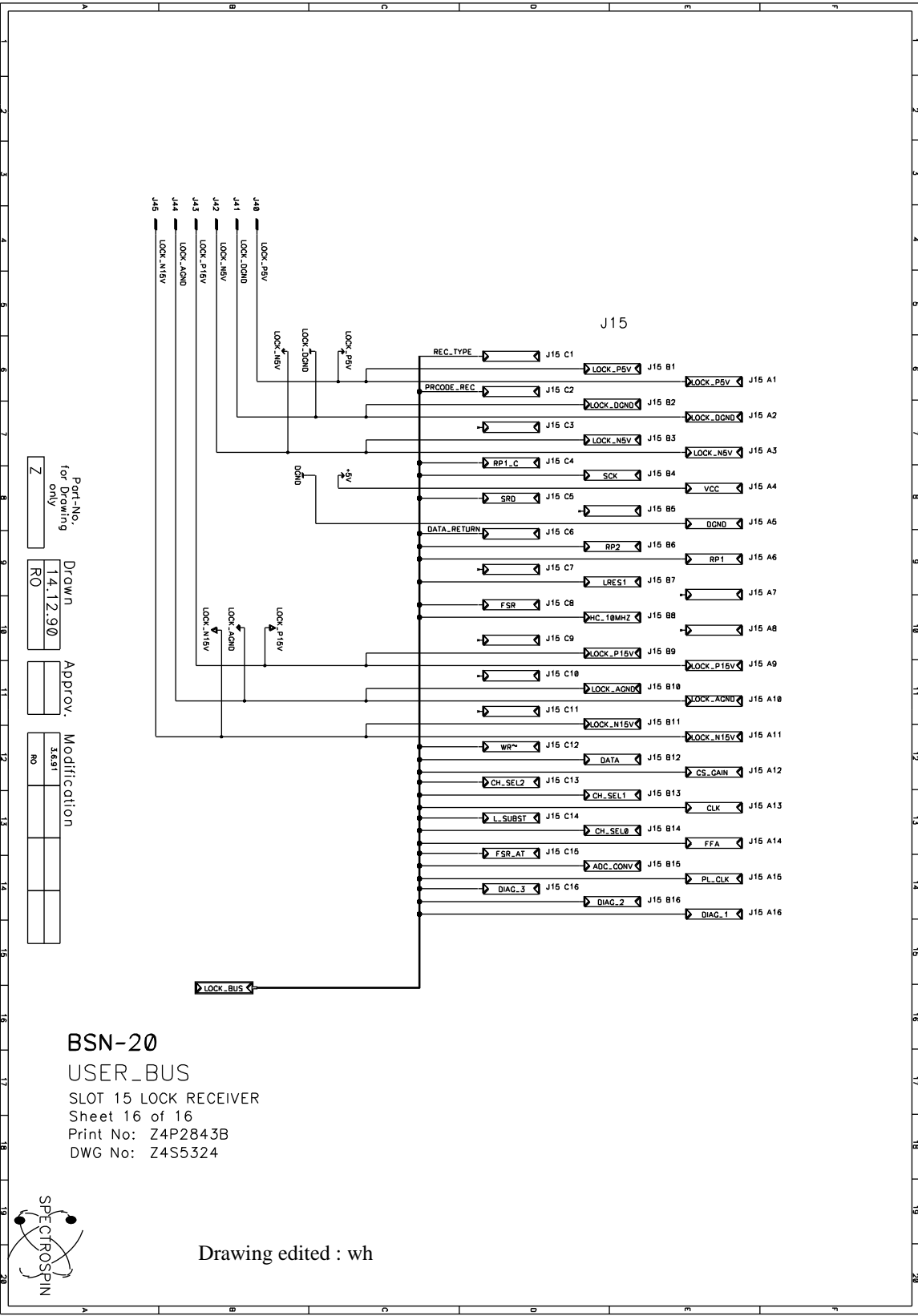

Part-No.  
for Drawing  
only

Drawn  
14.12.90  
RO

Approv.

Modification  
3.6.91  
RO

**BSN-20**  
**USER\_BUS**  
 SLOT 15 LOCK RECEIVER  
 Sheet 16 of 16  
 Print No: Z4P2843B  
 DWG No: Z4S5324

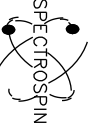

Drawing edited : wh

## Power supply overview

7.1

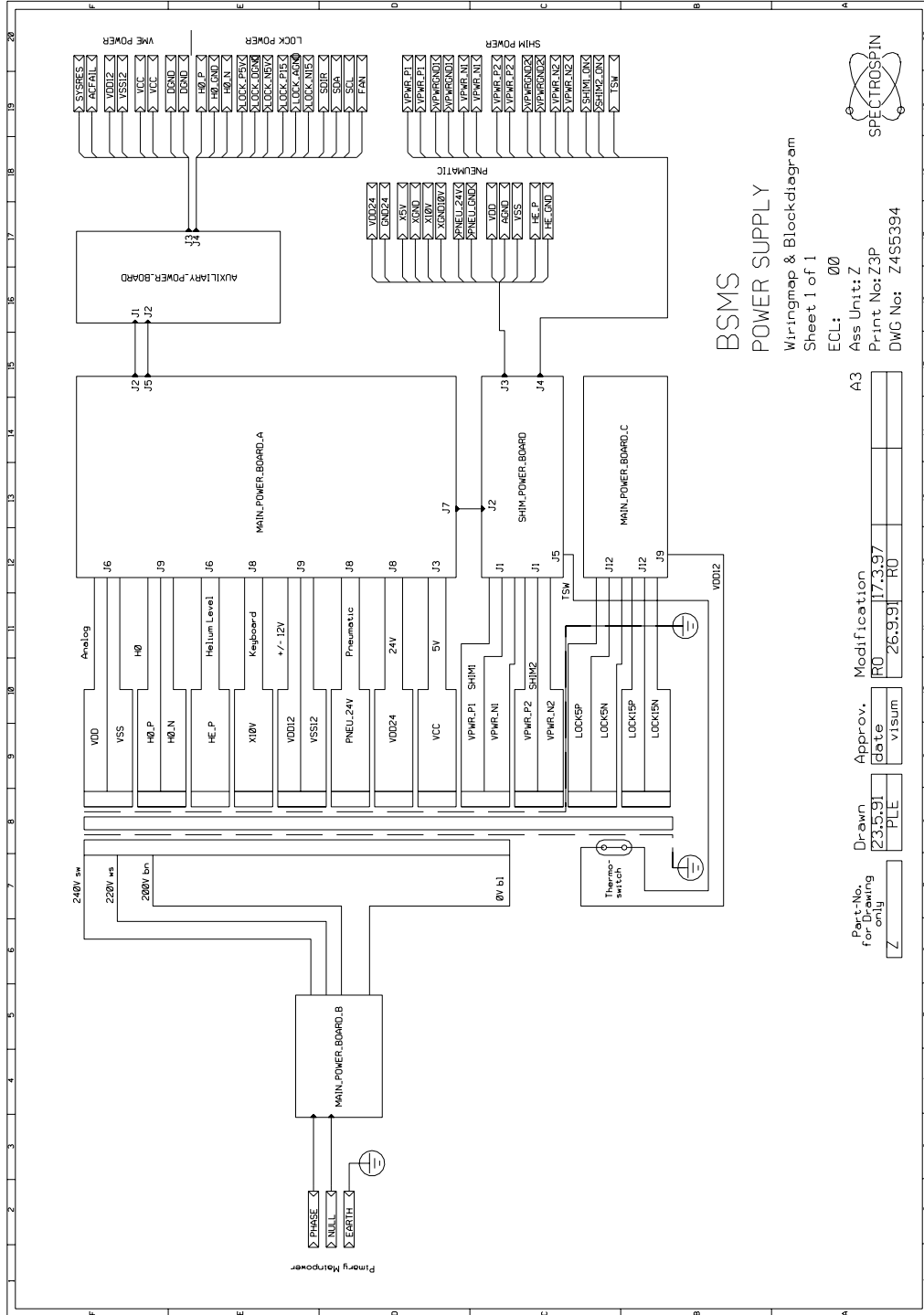

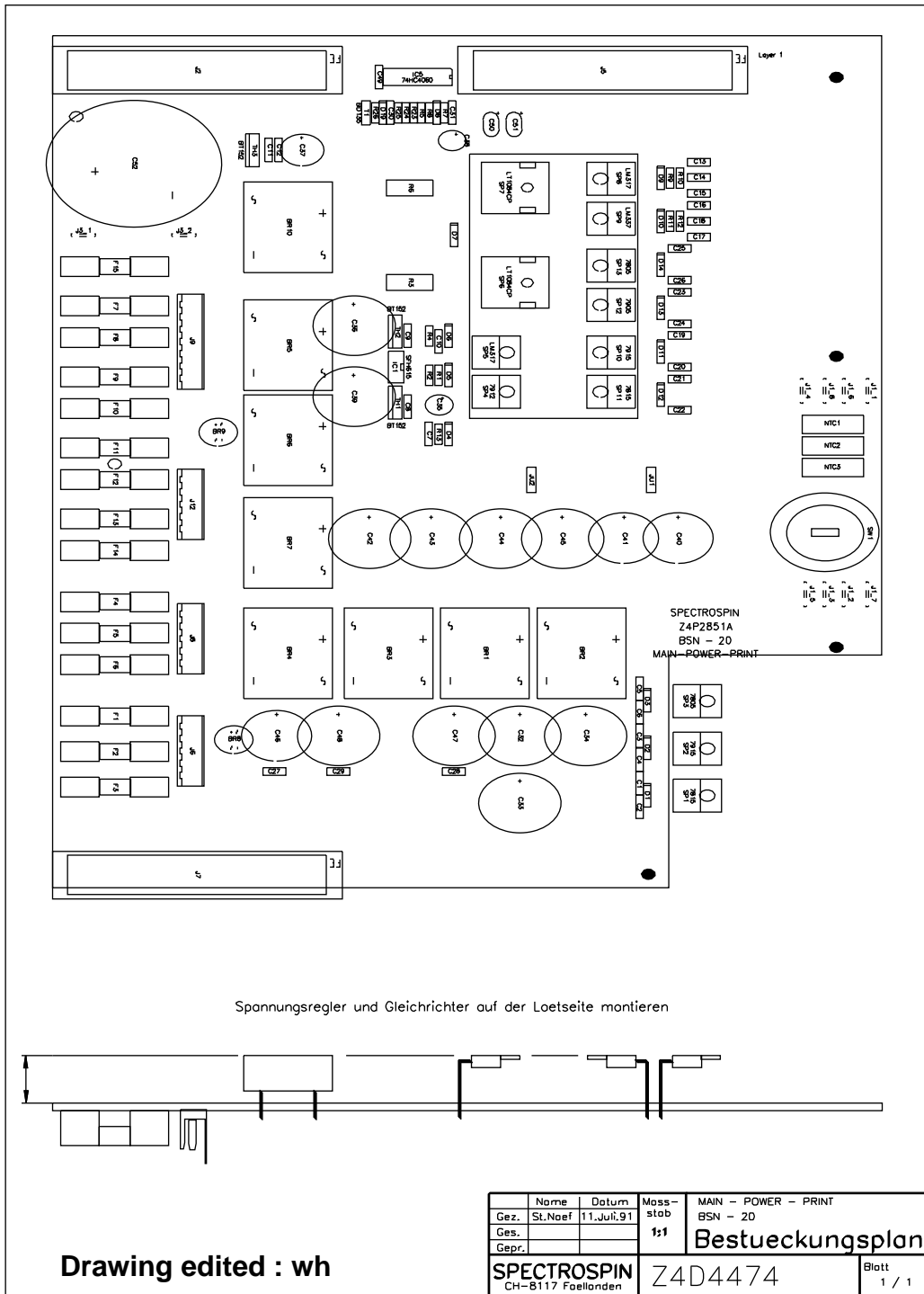

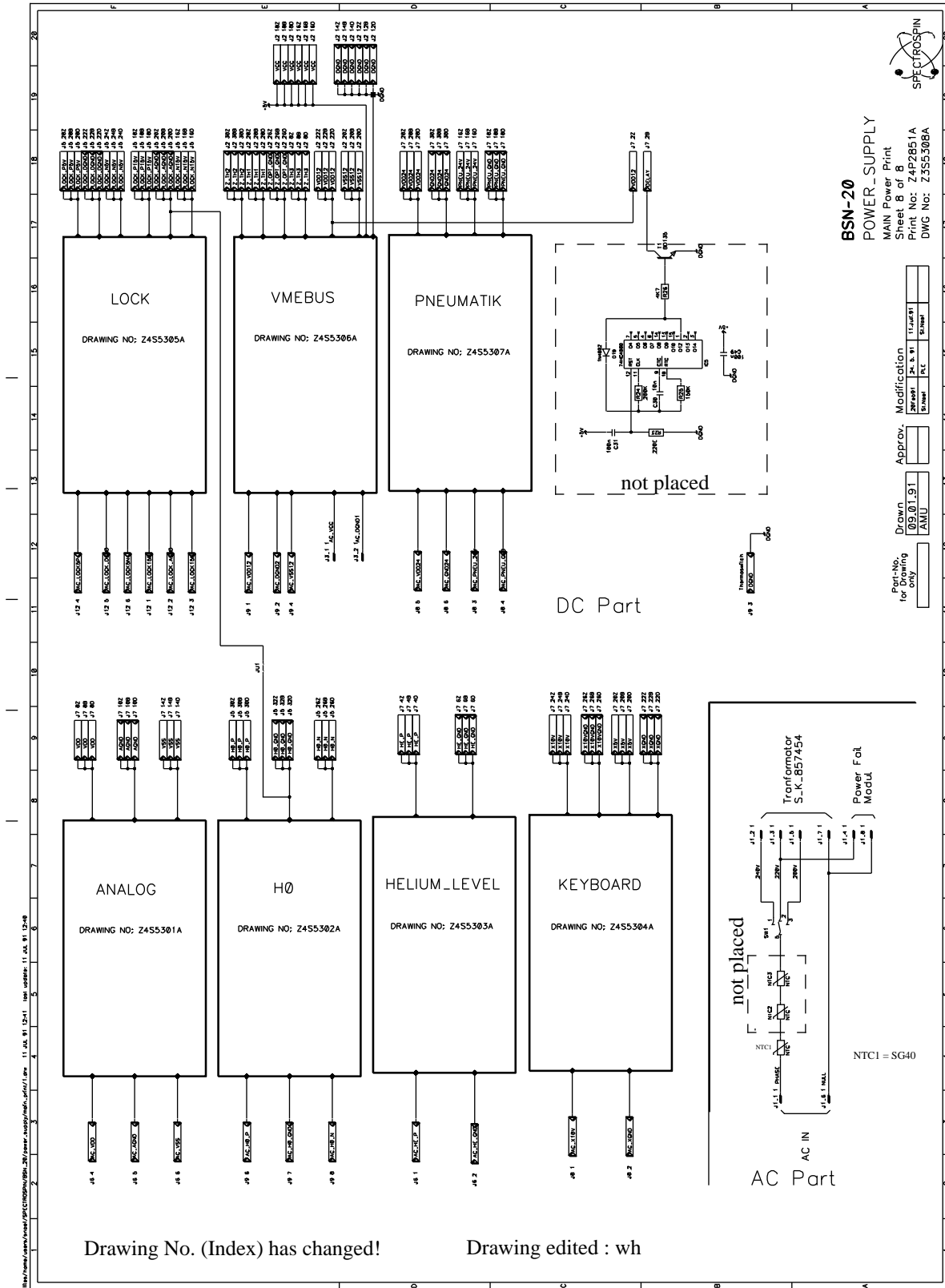

/files/home/users/snoet/SPECTROSPIN/BSN\_20/power\_supply/main\_print/ANALOG/1.dwg 11 JUL 91 12:43 last update: 11 JUL 91 12:43

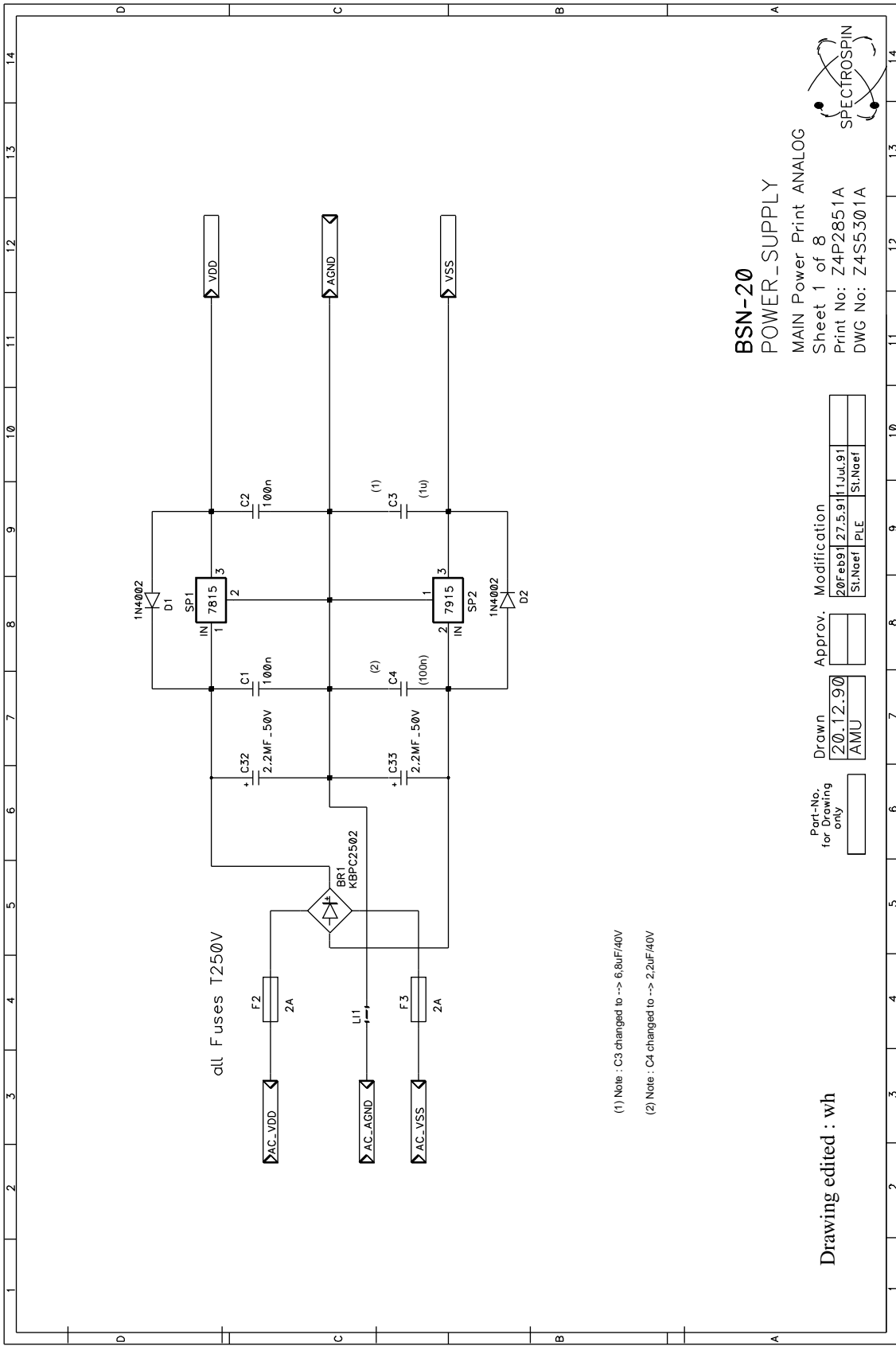

**BSN-20**  
**POWER\_SUPPLY**  
 MAIN Power Print ANALOG  
 Sheet 1 of 8  
 Print No: Z4P2851A  
 DWG No: Z4S5301A



Part-No. for Drawing only	Drawn	Approv.	Modification
	20.12.90 AMU		20feb91 27.5.91 1 Jul 91 St.Naef PLE St.Naef

Drawing edited : wh



/files/home/users/snoef/SPECTROSPIN/BSN\_20/power\_supply/main\_print/H0/1.drw 11 JUL 91 12:44 last update: 11 JUL 91 12:44

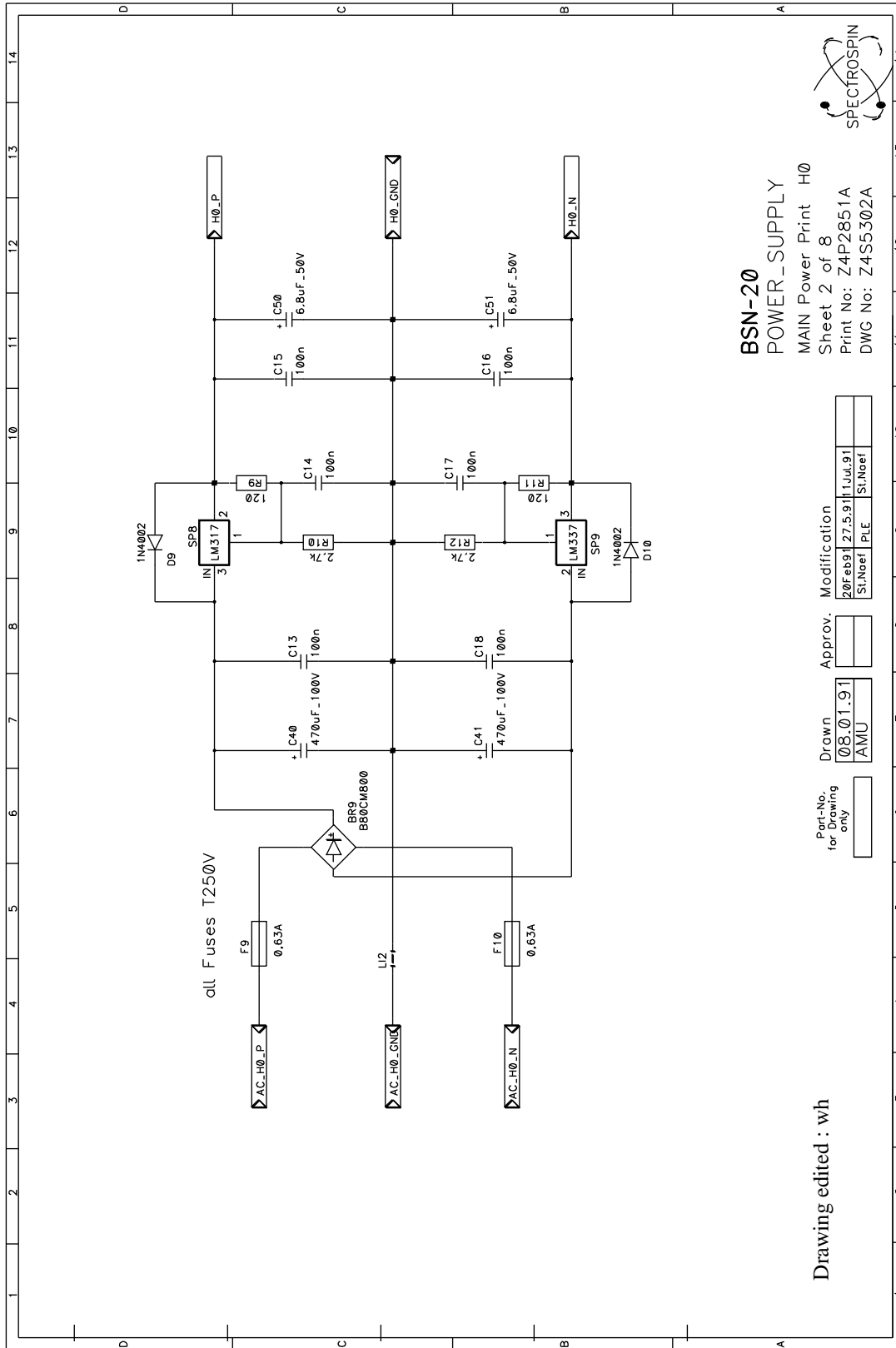

Drawing edited : wh

Part-No.  
for Drawing  
only

Drawn  
08.01.91  
AMU

Approv.

Modification  
20Feb91 27.5.91 1Jul91  
S1.Noef PLE S1.Noef

**BSN-20**  
**POWER\_SUPPLY**  
MAIN Power Print H0  
Sheet 2 of 8  
Print No: Z4P2851A  
DWG No: Z4S5302A

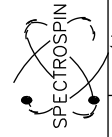

/files/home/users/snaef/SPECTROSPIN/BSN\_20/power\_supply/main\_print/HELIUM\_LEVEL/1.drw 11 JUL 91 12:46 last update: 11 JUL 91 12:46

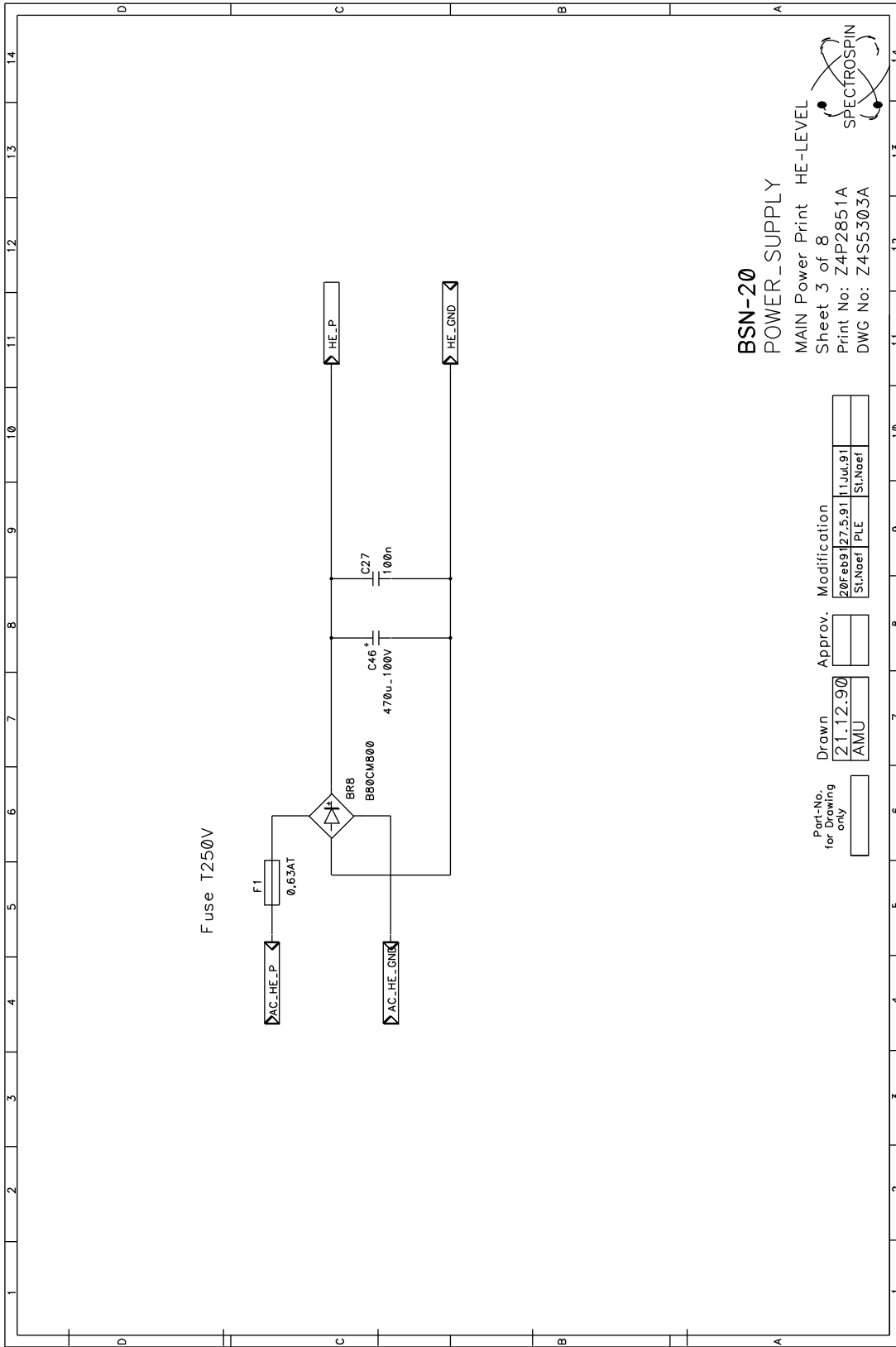

**BSN-20**  
**POWER\_SUPPLY**  
 MAIN Power Print HE-LEVEL  
 Sheet 3 of 8  
 Print No: Z4P2851A  
 DWG No: Z4S5303A

Part-No. for Drawing only	Drawn	Approv.	Modification
	21.12.90 AMU		20Feb91 27.5.91 11Jul91 St.Naef PLE St.Naef

SPECTROSPIN

/files/home/users/snoef/SPECTROSPIN/BSN\_20/power\_supply/main\_print/KEYBOARD/1.drw 11 JUL 91 12:47 last update: 11 JUL 91 12:47

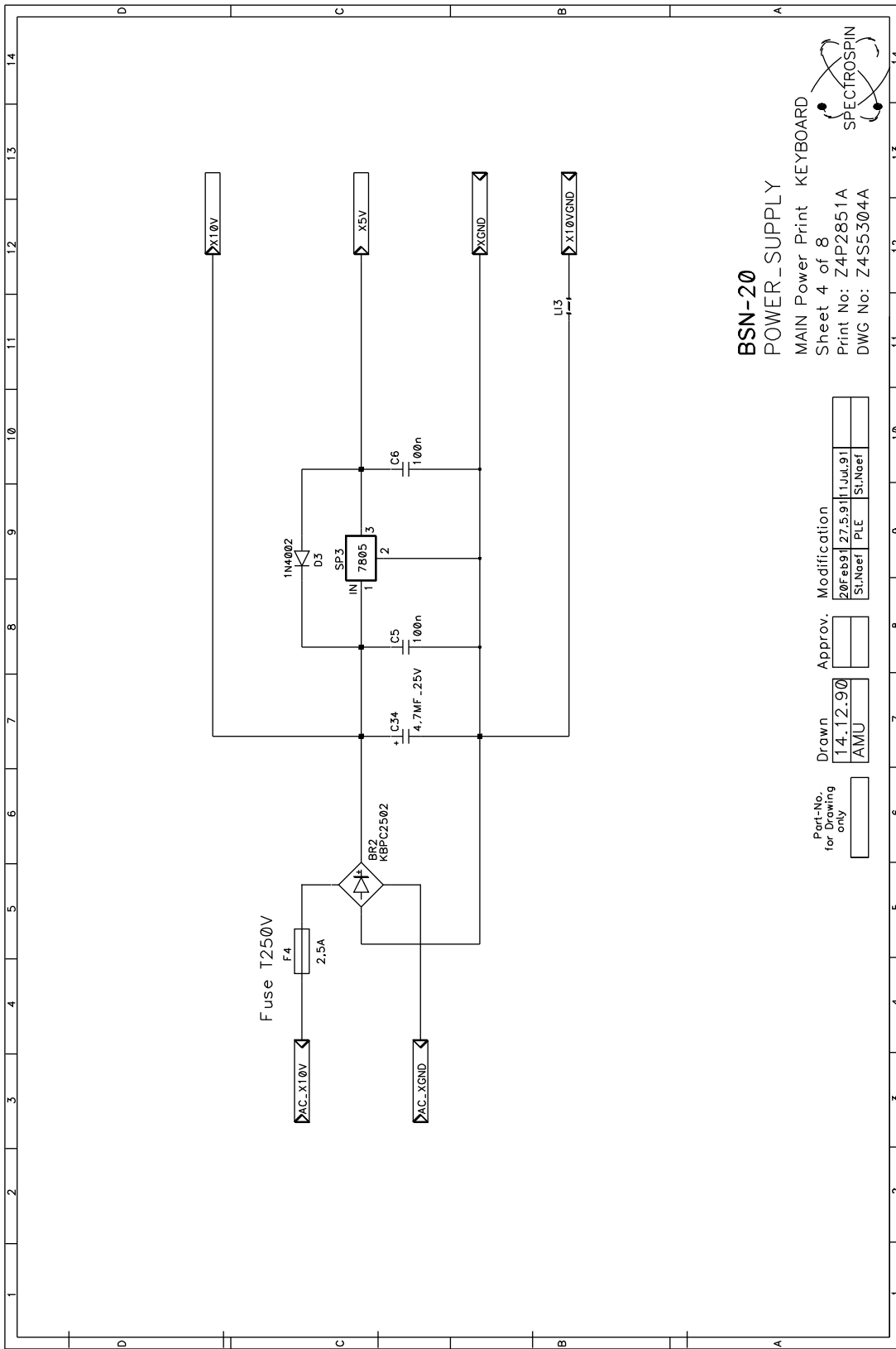

**BSN-20**  
**POWER\_SUPPLY**

MAIN Power Print KEYBOARD

Sheet 4 of 8

Print No: Z4P2851A

DWG No: Z4S5304A

Part-No. for Drawing only	Drawn	Approv.	Modification
	14.12.90 AMU		20 Feb 91 27.5.91 1 Jul 91 St.Naef PLE St.Naef



/files/home/users/snoei/SPECTROSPIN/BSN\_20/power\_supply/main\_print/LOCK/1.dwg 11 JUL 91 12:49 last update: 11 JUL 91 12:49

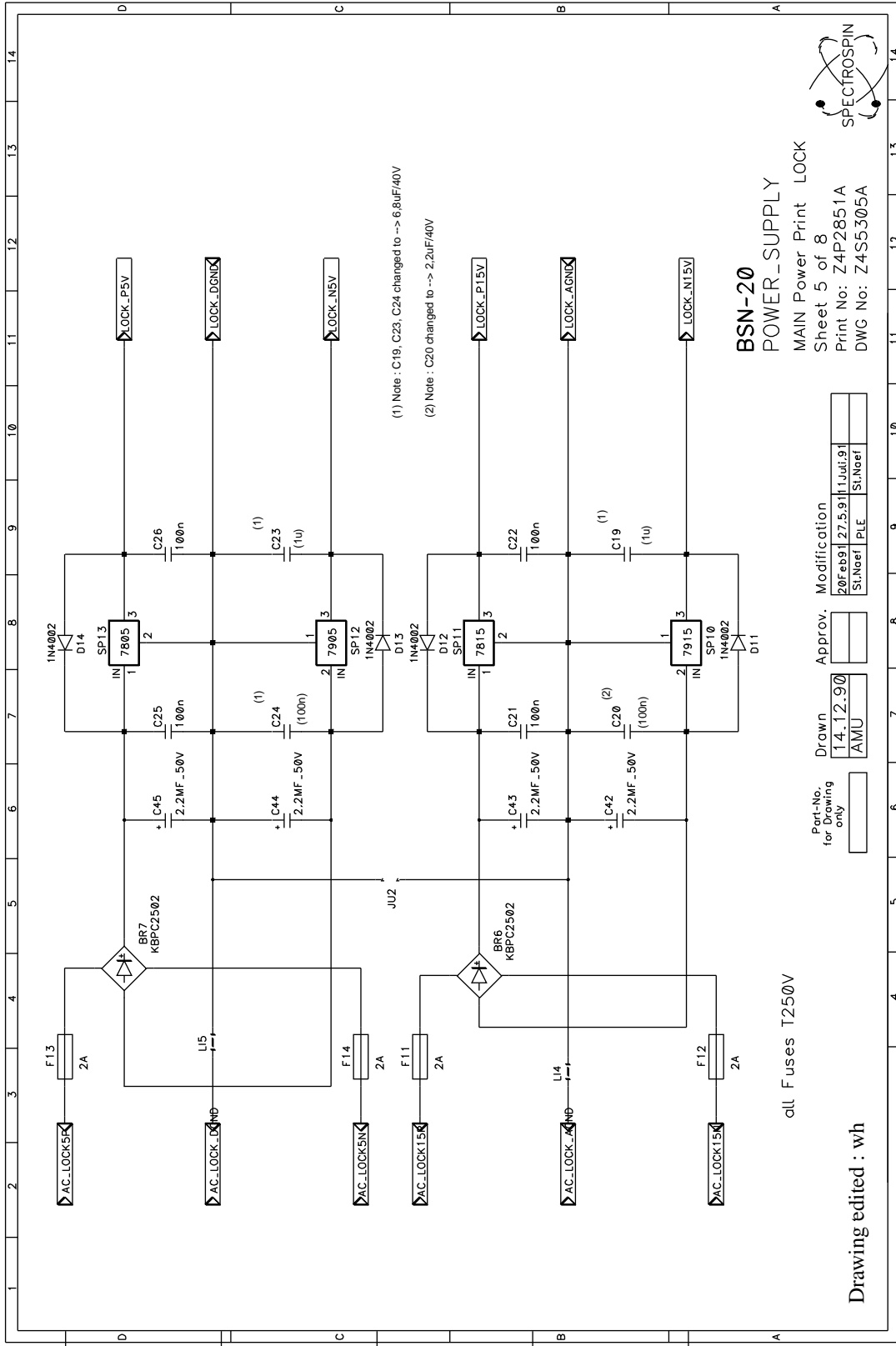

**BSN-20**  
 POWER\_SUPPLY LOCK  
 MAIN Power Print LOCK  
 Sheet 5 of 8  
 Print No: Z4P2851A  
 DWG No: Z4S5305A

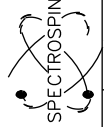

Part-No.	Modification
for Drawing only	
14.12.90	20Feb91 27.5.91
AMU	SL.Noet PLE
	SL.Noet

Drawn	Approv.
AMU	

all Fuses T250V

Drawing edited : wh



/files/home/users/snaef//SPECTROSPIN/BSN\_20/power\_supply/main\_print/PNEUMATIK/1.drw 11 JUL 91 12:52 last update: 11 JUL 91 12:52

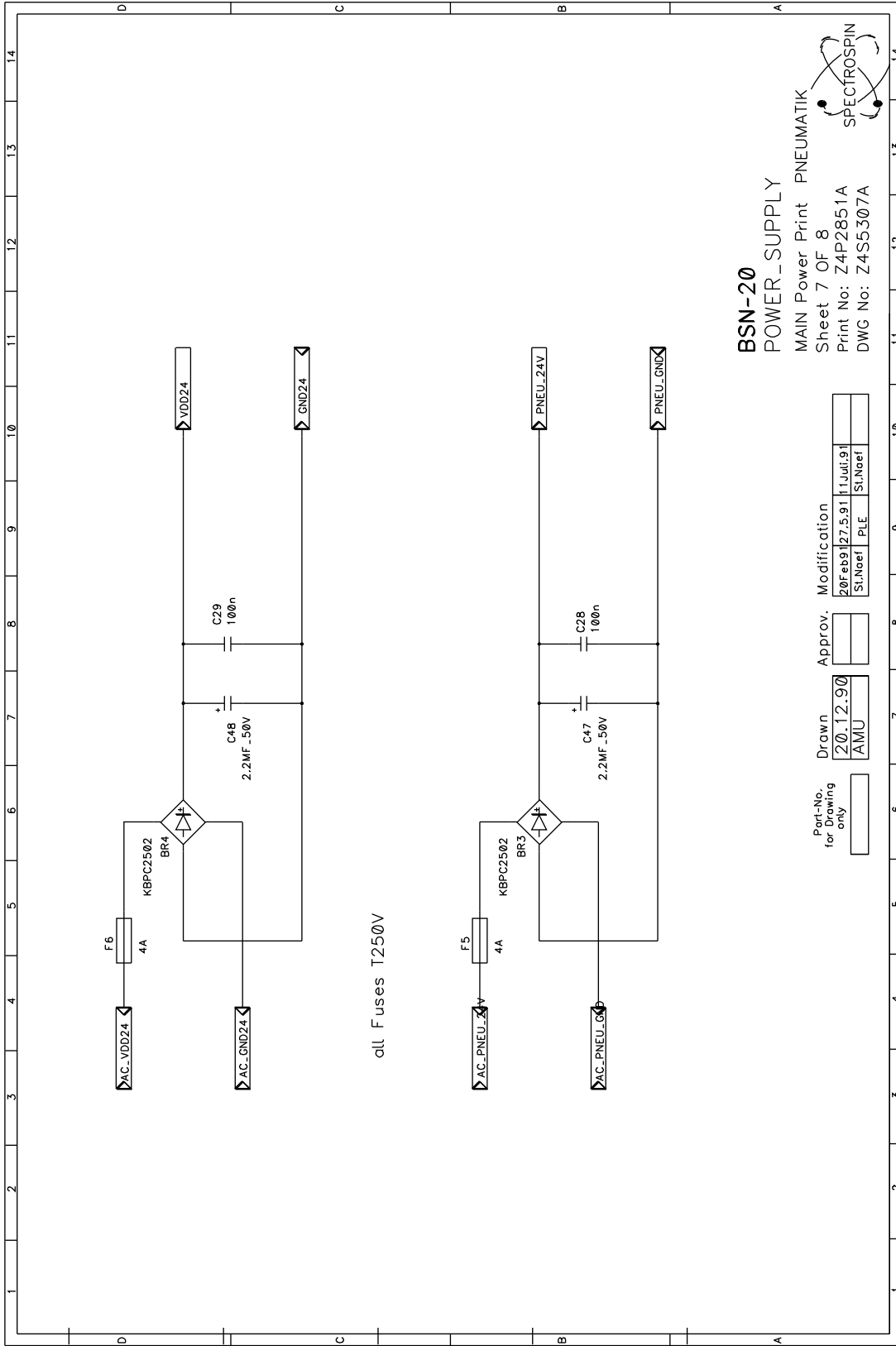

**BSN-20**  
**POWER\_SUPPLY**  
 MAIN Power Print PNEUMATIK  
 Sheet 7 OF 8  
 Print No: Z4P2851A  
 DWG No: Z4S5307A

Part-No. for Drawing only	Drawn	Approv.	Modification
	20.12.90 AMU		20Feb91 27.5.91 11Jul91 St.Naef PLE St.Naef



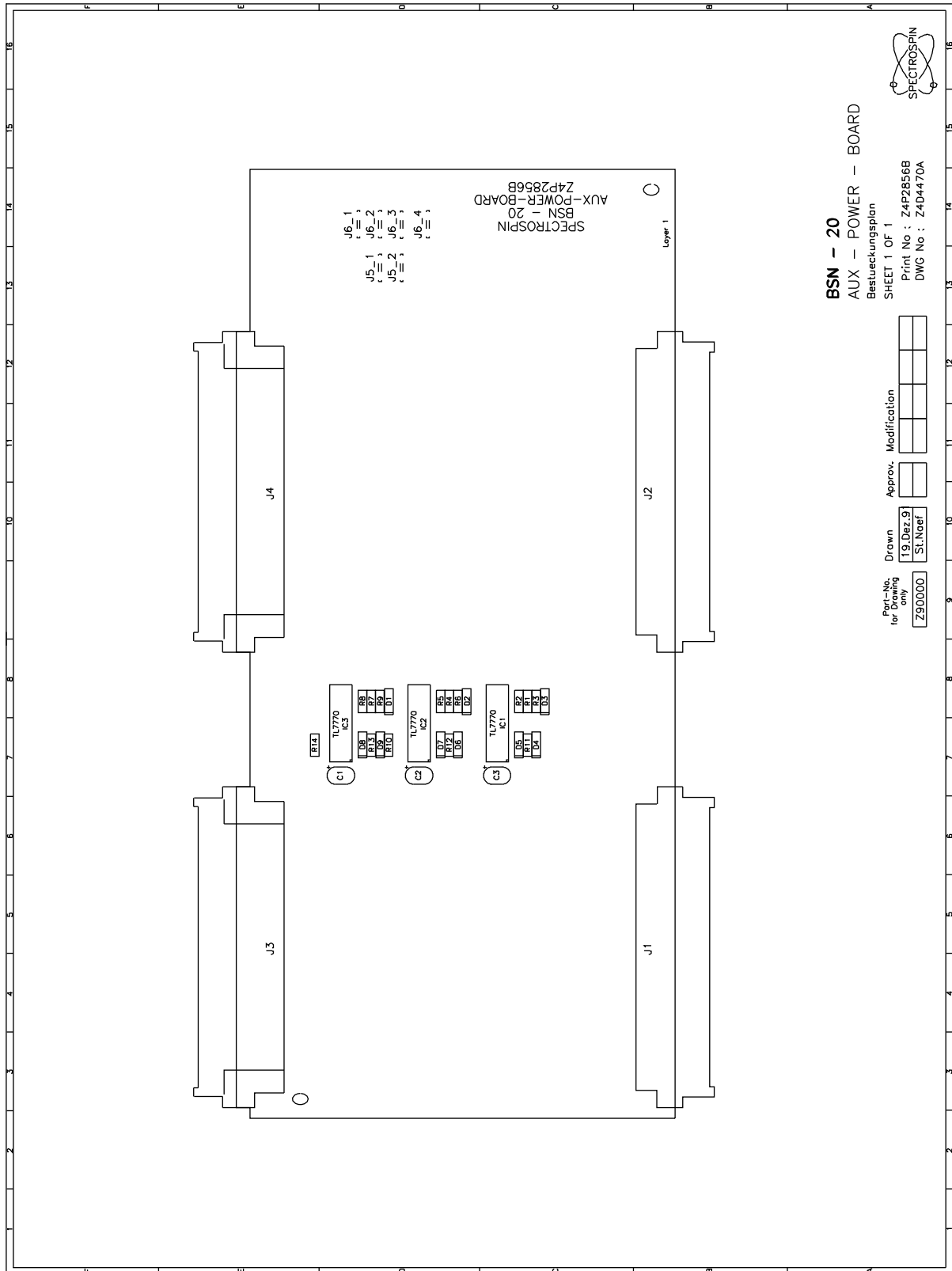





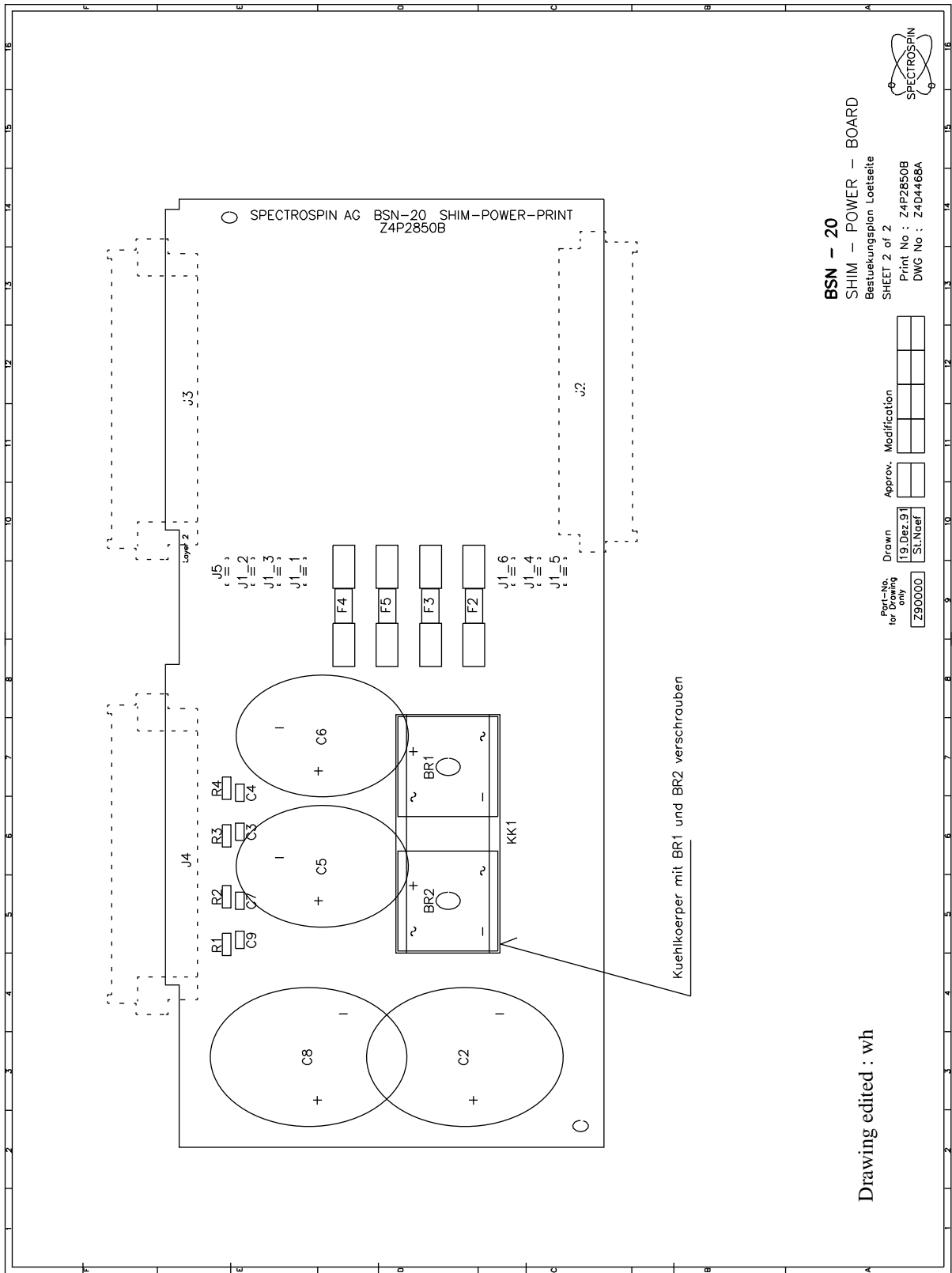



# Index

<b>Numerics</b>	
	68000.....21
<b>A</b>	
	air filter.....5
<b>B</b>	
	BSMS .....3
	BSMS Service Tool .....4
<b>C</b>	
	CPU.....19
<b>F</b>	
	fans.....5
	frame ground .....7
	Fuses .....15
<b>G</b>	
	Grounding .....9
<b>K</b>	
	KBC .....25
<b>L</b>	
	Line Module .....5
<b>M</b>	
	mains filter .....5
	Mains Fuse .....8
	mains fuse .....5
	mains switch.....5
<b>R</b>	
	reset.....22
<b>S</b>	
	SYSRESET .....22
<b>T</b>	
	Troubleshooting .....3
<b>U</b>	
	USERBus .....7
<b>V</b>	
	VMEBus .....7



# List of Figures

<b>1.General Description</b>	<b>3</b>
<b>2.BSMS Chassis and Buses</b>	<b>5</b>
Figure 1: Front and Back Racks in the BSMS (Side View) .....	5
Figure 2: Slots in the BSMS (Front View) .....	6
Figure 3: VMEBus and USERBus in the BSMS (Front View).....	7
<b>3.Power Supply Module</b>	<b>9</b>
Figure 4: Power Supply Module in the BSMS (Back View) .....	9
Figure 5: Overview of the Power Supply Module (Part One) .....	10
Figure 6: Overview of the Power Supply Module (Part Two) .....	11
Figure 7: Primary Voltage Selection Switch .....	12
<b>4.Central Processing Board CPU</b>	<b>19</b>
Figure 8: BSMS CPU in the BSMS .....	19
Figure 9: CPU Block Diagram .....	20
<b>5.BSMS Keyboard KBC</b>	<b>25</b>
Figure 10: Layout of the BSMS Keyboard (Version BOSS) .....	26
Figure 11: Layout of the BSMS Keyboard (Version HR-20) .....	27
Figure 12: BSMS Keyboard Block Diagram .....	28
<b>6.Buses and Wiring</b>	<b>31</b>
<b>7.Schematics</b>	<b>51</b>



# List of Tables

<b>1.General Description .....</b>	<b>3</b>
<b>2.BSMS Chassis and Buses .....</b>	<b>5</b>
Table 1. Technical Data of the BSMS Chassis .....	8
Table 2. Technical Data of the Line Module .....	8
<b>3.Power Supply Module .....</b>	<b>9</b>
Table 3. Power Supply Fuses and Corresponding LED's .....	16
Table 4. Regulated Voltages .....	17
Table 5. Non-Regulated Voltages .....	18
<b>4.Central Processing Board CPU.....</b>	<b>19</b>
Table 6. Technical Data from the CPU Controller Section .....	23
<b>5.BSMS Keyboard KBC.....</b>	<b>25</b>
Table 7. Technical Data of the BSMS Keyboard .....	30
<b>6.Buses and Wiring .....</b>	<b>31</b>
<b>7.Schematics .....</b>	<b>51</b>

