

# BRUKER

Best-  
NMR

221101

## **215 Liquid Handler Up-Grade Manual**

For Up-Grade to Run with XWINNMR Vers. 3.1

Manual # H9771

## H9770 BEST –NMR Up-Grade Kit to XWINNMR 3.1

The kit will include:

No.	Article	Bruker #	Comment
500mm	Capillary FEP 1/16" x 1.0	84525	Dilutor – Wash Switch
4000mm	Capillary FEP 1/16" x 1.0	84525	Wash Switch – Needle
1500mm	Capillary FEP 1/16" x 1.0	84525	Wash Switch – 819 Valve4
90mm	Capillary FEP 1/16" x 0.5	84714	Inj. Port – 819 Valve
1000mm	Capillary FEP 1/16" x 1.0	84525	819 Valve 3 – Waste
1000mm	Capillary FEP 1/16" x 1.0	84525	819 Valve 6 – Waste
3	UNF 10/32 Fingertight long	69485	Fitting long
7	UNF 10/32 Fingertight short	85561	Fitting short head
2	Flangeless Fitting 1/16"	84531	¼" Fitting f. 1/16" Capillary
2	Flangeless Ferrule 1/16"	19701	¼" Ferrule f. 1/16" Capillary
1	Flangeless Fitting 1/8"	84532	¼" Fitting f. 1/8" Capillary
1	Flangeless Ferrule 1/8"	84322	¼" Ferrule f. 1/8" Capillary
1	Y-Piece f. 10mm PTFE Hose	85489	Y-Piece f. 10mm PTFE hose
1	UNF 10/32 Plug	19707	Closing Gas Cap. at Rec. Mod.
1	UNF 10/32 Adapter PEEK	84518	Closing Gas Cap. at Rec. Mod.
2	PTFE Hose Clamps	85490	for waste hose
1	Serial Cable	HZ10144	PC COM x - Gilson RS232
1	Wash Switch device	H10067	for a more efficient washing action
1	Software Manual for 3.1	H9771	

### General information

### **Current Capillary Setup with XWINNMR 3.0**

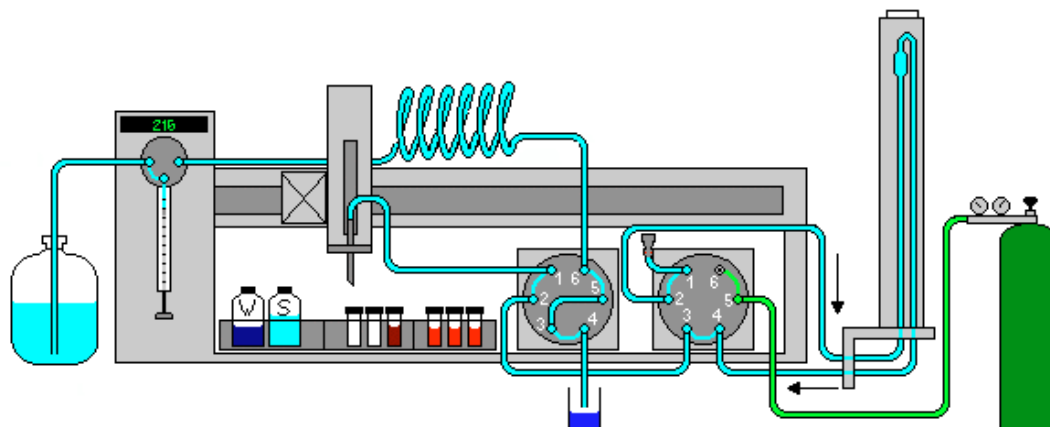



## New Capillary Setup running under XWINNMR 3.1

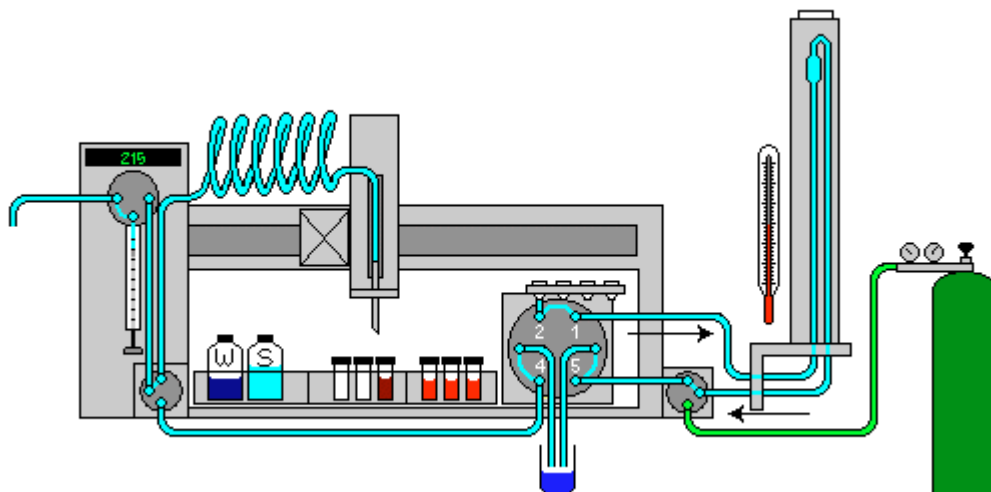

The new setup will be introduced with a new and more flexible BEST-NMR software package. The direct control of the Gilson will be used and therefore no **Gilson 606M interface** and no **keypad** with the **ABIMED software** will be needed. Also one 819 valve will be enough to offer all actions that are currently implemented. This change was possible by re-engineering the flow path. This new software will be introduced with the Release to XWINNMR 3.1

**With the introduction of the new BEST version you have to modify the “Recover Module” on the current system! This is very important to support the new feature of the pulsing gas flow!**

### Doing the Up-Grade

- Switch the entire system off
- Disconnect the keypad on the back panel of the 215
- Disconnect the 606M interface (current and GSIOC cable)
- Disconnect the 819 valve actuator which is supporting the dilutor and the needle (current and GSIOC cable)
- Connect the GSIOC cable coming from the Injection Port 819 Actuator to the main GSIOC socket of the 215
- Disconnect all capillaries at the 819 valve actuator which is supporting the dilutor and the needle .
- Follow the connection plan using the capillaries out of the Up-Grade Kit
- Connect the 215 at its RS232 port with the new serial cable HZ10144/A and the other end to the corresponding port at your NMR system.
- **It is recommended to use a free COM port at your computer to achieve the highest possible performance for the communication !**
- When all the connections are complete, switch both the 215 and 819 on and start the BEST-NMR software.
- You have to set new Hardware, Holder and Solvent menus, but the software will provide you with a method conversion routine, for your existing methods.

## New Connection Plan for BEST Vers.3.1

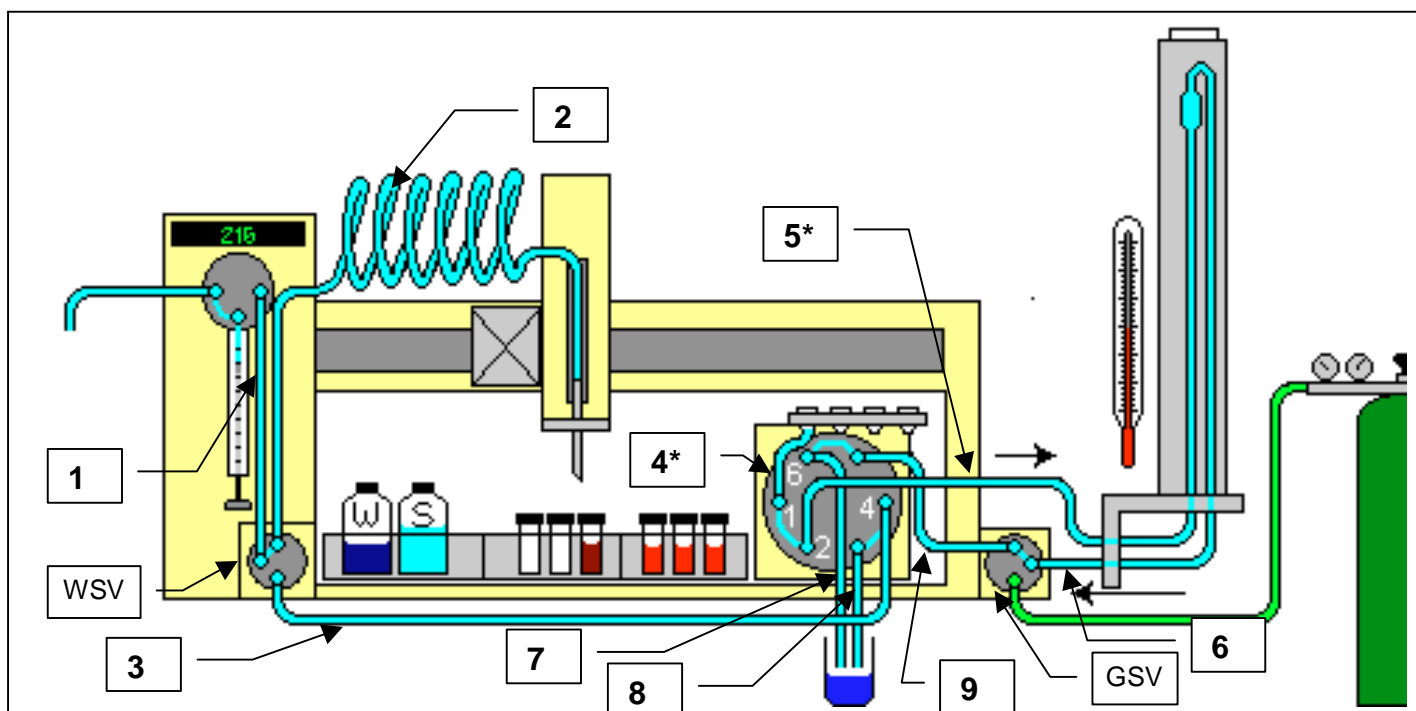

Nr.	Length	Dimension	Order #	Position	Fittings
1	500mm	Capillary FEP 1/16" x 1.0	84525	Dilutor – Wash Switch	1/4" + 1/4"
2	4000mm	Capillary FEP 1/16" x 1.0	84525	Wash Switch – Needle	1/4" + 1/4"
3	1500mm	Capillary FEP 1/16" x 1.0	84525	Wash Switch – 819 Valve Port 4	1/4" + UNF L
4	90mm	Capillary FEP 1/16" x 0.5	84714	Inj. Port – 819 Valve Port 1	1/4 + UNF L
5	3000mm	Capillary FEP 1/16" x 0.5	84714	819 Valve Port 2 – Probe	UNF S + UNF L
6	3000mm	Capillary FEP 1/16" x 0.5	84714	Probe – Gas Switch	UNF L + UNF S
7	1000mm	Capillary FEP 1/16" x 1.0	84525	819 Valve Port 3 – Waste	UNF S + none
8	1000mm	Capillary FEP 1/16" x 1.0	84525	819 Valve Port 6 – Waste	UNF L + none
9*	300mm	Capillary FEP 1/16" x 0.5	84525	Gas Switch – 819 Valve Port 5	None + UNFS

\* this capillary will be already mounted at the “Recover Module”. This function will be replaced in future models by a so-called “Gas Valve Switch”. How to modify a “Recover Module” will be shown on the next page.

FEP → Fluoro Polymer

1/4" → Fitting 1/4" 28 Thread for 1/6" Capillary Flangeless (Nut and Ferrule)

UNF S → Fitting UNF 10/32 Nut short head for 1/6" Capillary

UNF L → Fitting UNF 10/32 Nut long for 1/6" Capillary

WSV → Wash Valve Module (Bruker #H10067)

GSV → Gas Valve Switch (Bruker #H10068)

## BEST – NMR Recover Module (current)

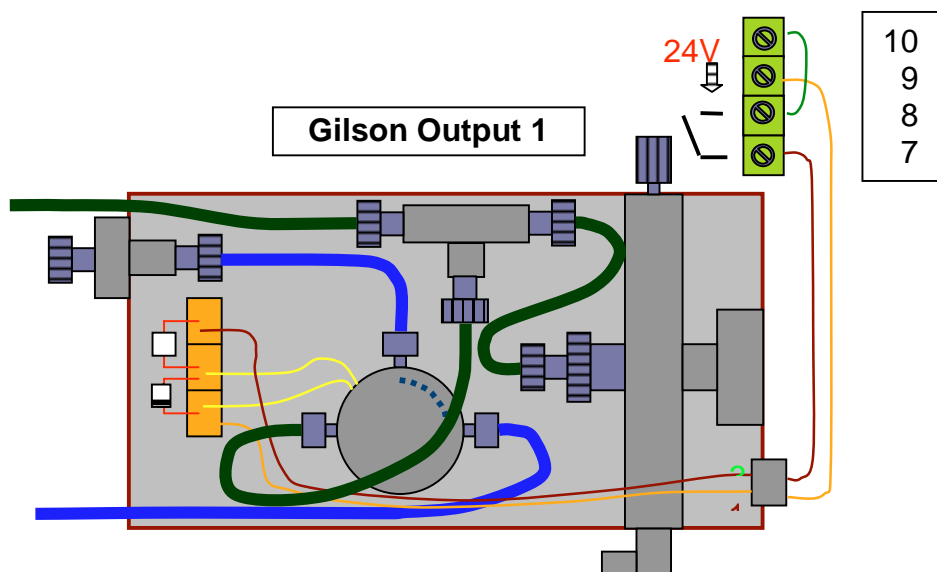

## 7BEST – NMR Gas Valve Switch (modified Recover Module)

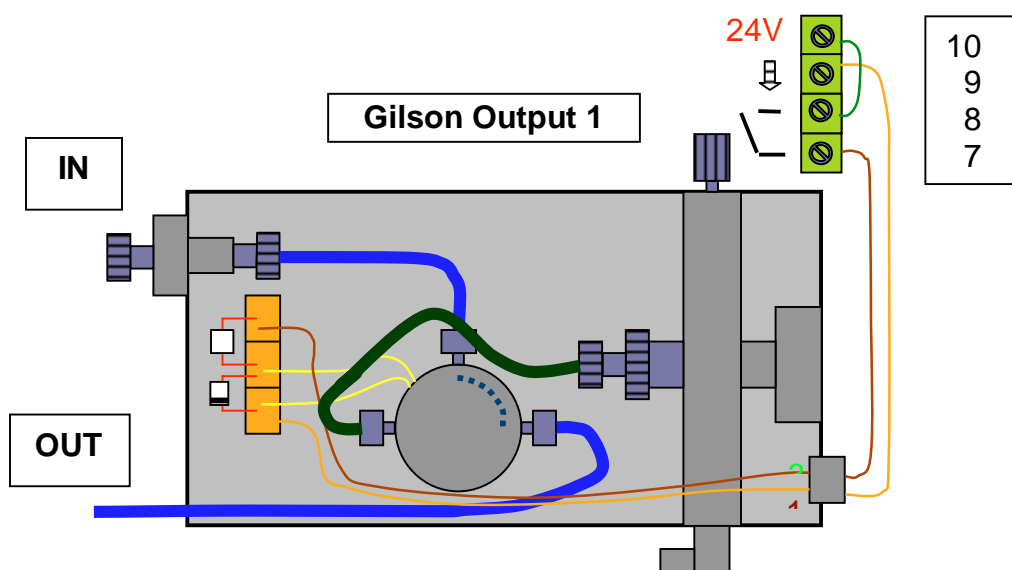

- The current “Recover Module” once modified will work like the future “Gas Valve Switch”.

You have three options for the modification of the current “Recover Module”

Either you just plug the outer PEEK capillary (connector and plug out of the Up-Grade Kit) or you are going to open the “Recover Module” and remove the T-piece with the Gas Out capillary. The Peek capillary coming from the Pressure regulator will then be connected directly to the switching valve. (see drawing) Removing the T-piece could be sometimes a bit tricky, therefore one also could think about using the PEEK gas line like described in the next chapter.

As an alternative, you can mount the out coming PEEK gas capillary to an additional closed injection port (Bruker #HZ06807) which will be mounted to one of the three port holes on the Gilson injection port plate. With this you can provide inert gas gaps for you application.





## Features of the new BEST Versions

- direct control without the Gilson keypad, 606 Interface and BRUK\_XL software. This leads also to faster implementation of new features
- total freedom in setting the gas and solvent gaps sizes
- total freedom in choosing the gap solvents
- the possibility of setting the sample itself as solvent gap
- choice of using inert gas for the gas gaps from defined closed injection port
- choice of getting wash solvents out of larger reservoirs from a defined closed injection port
- possibility of using five sample racks if the wash solvents will be used from the closed injection ports or if the "Wash Switch Valve" will be sufficient enough for the customers application. (implementation in progress)
- recover not only in vials, but also into a port (e.g. SAR-NMR)
- freedom to choose the position of source- and recover racks
- WDS with an enhanced cleaning function like a waiting time for the cleaning segment to react on the flow cell surface
- pulsing drying gas for more efficient drying procedure
- With the new connection design (only one valve) we also will improve the sample transport and minimize the back mixing.

To use all the new features please read the software manual carefully.